

Upgrade kits are compatible with the following parts:
 Enhanced Net-Verse cabinets (part numbers beginning with DAE and DNE)
 Enhanced Net-Verse Doors (part numbers ending with FDE* and RDE*)

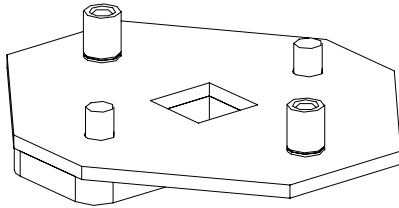

Door Handle Cam Assembly
Qty. 2

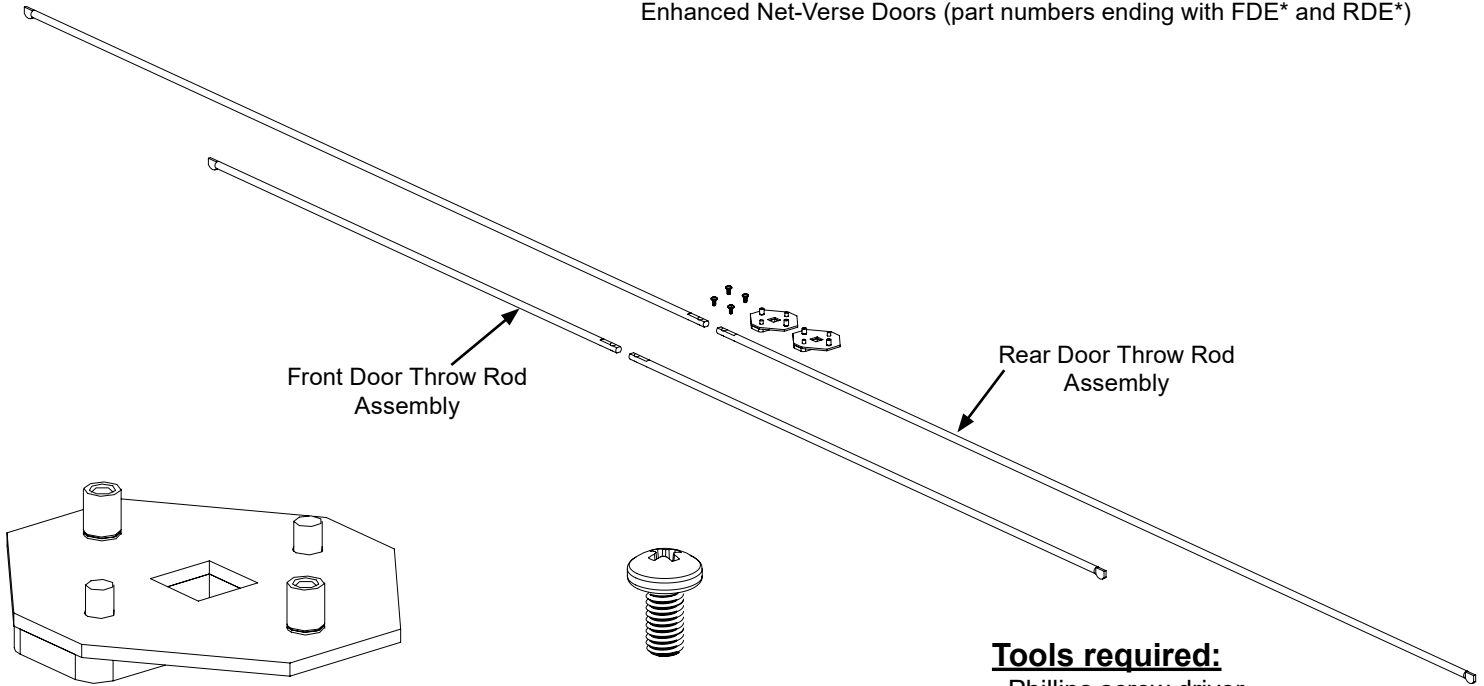

M3x.5 x 6mm Pan Head Screw
Qty. 2

Tools required:

- Phillips screw driver
- 7mm Hex Driver

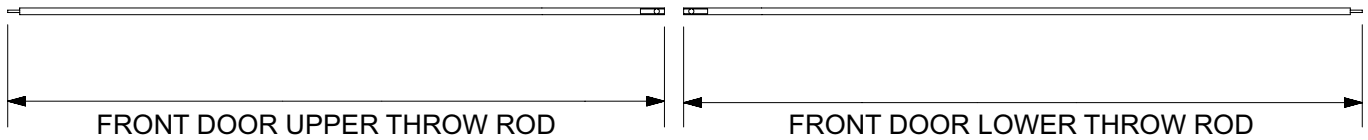
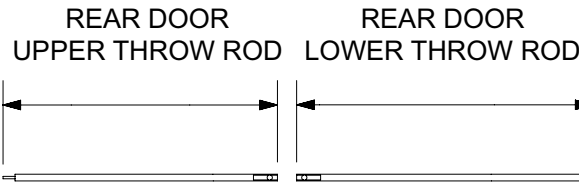

| PART NUMBER | CABINET HEIGHT | FRONT DOOR UPPER THROW ROD | FRONT DOOR LOWER THROW ROD | REAR DOOR UPPER THROW ROD | REAR DOOR LOWER THROW ROD |
|-------------|----------------|----------------------------|----------------------------|---------------------------|---------------------------|
| NVMK42 | 42RU | 505mm | 605mm | 903mm | 1003mm |
| NVMK45 | 45RU | 618mm | 713mm | 972mm | 1072mm |
| NVMK48 | 48RU | 618mm | 713mm | 1039mm | 1139mm |

Remove Door Rods from Door

- Remove Hardware shown
- Slide Door Rods toward top and bottom of door through brackets to remove

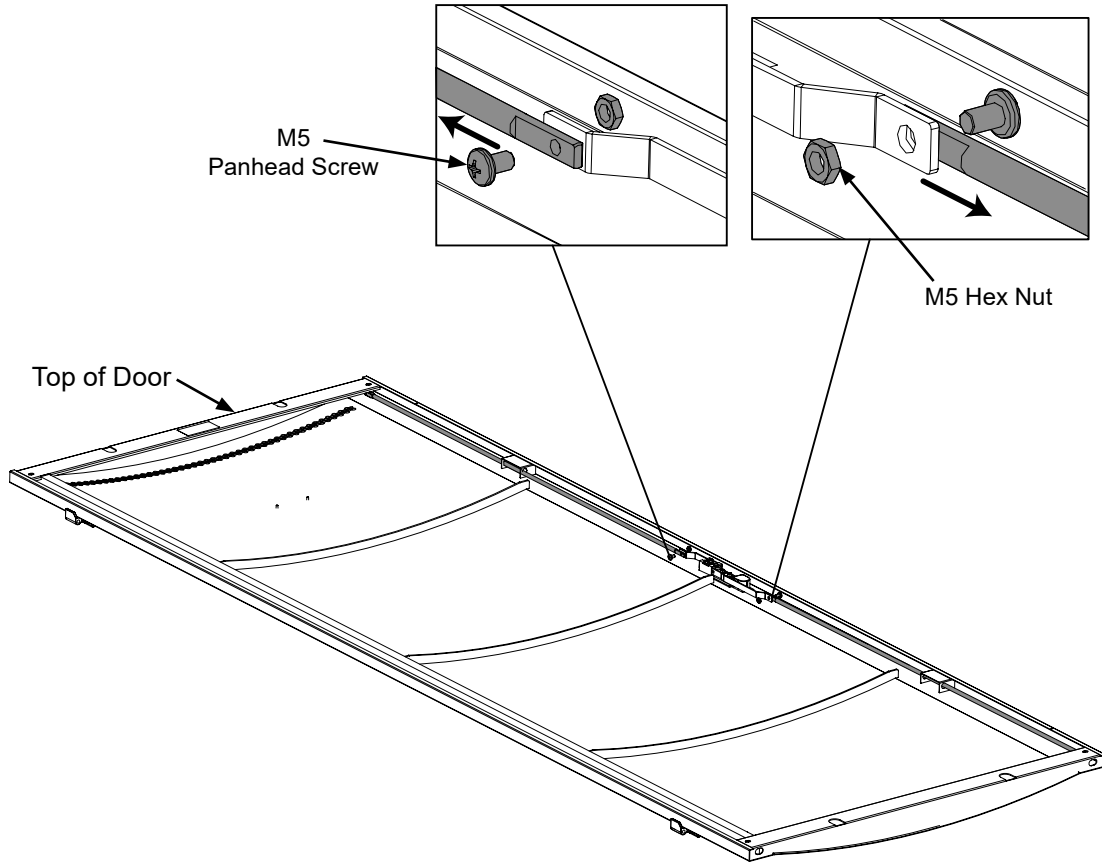

Hardware Removal

- Remove Hardware shown
- Remove additional Door Latch on Rear Door

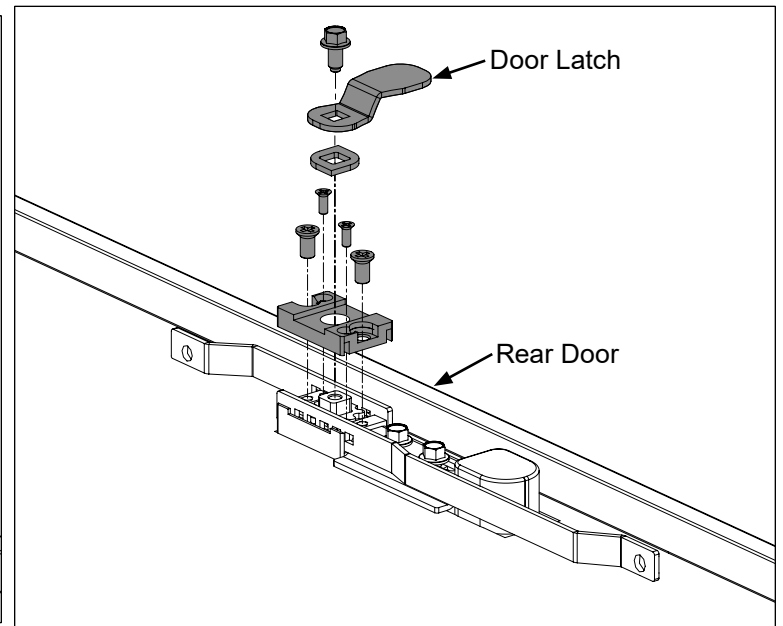
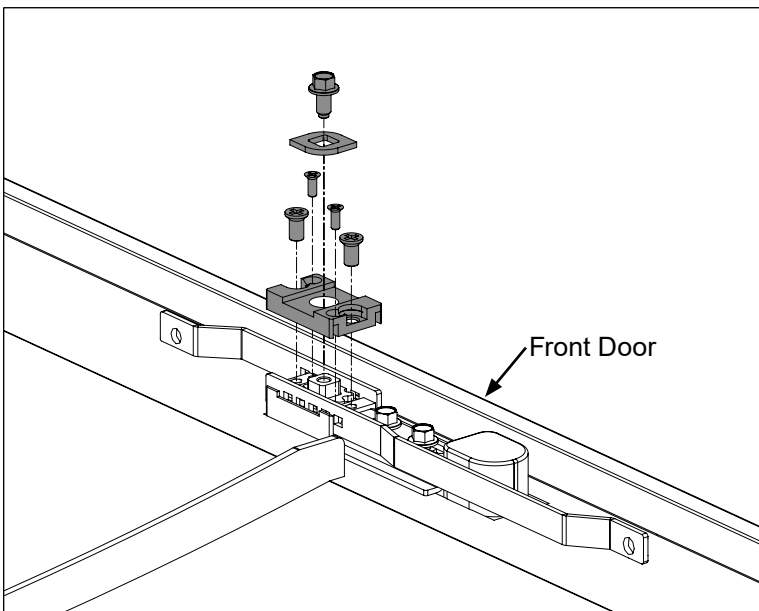

Remove Transmission Bars and Gear

- Remove Transmission Bars and Gear from Lock

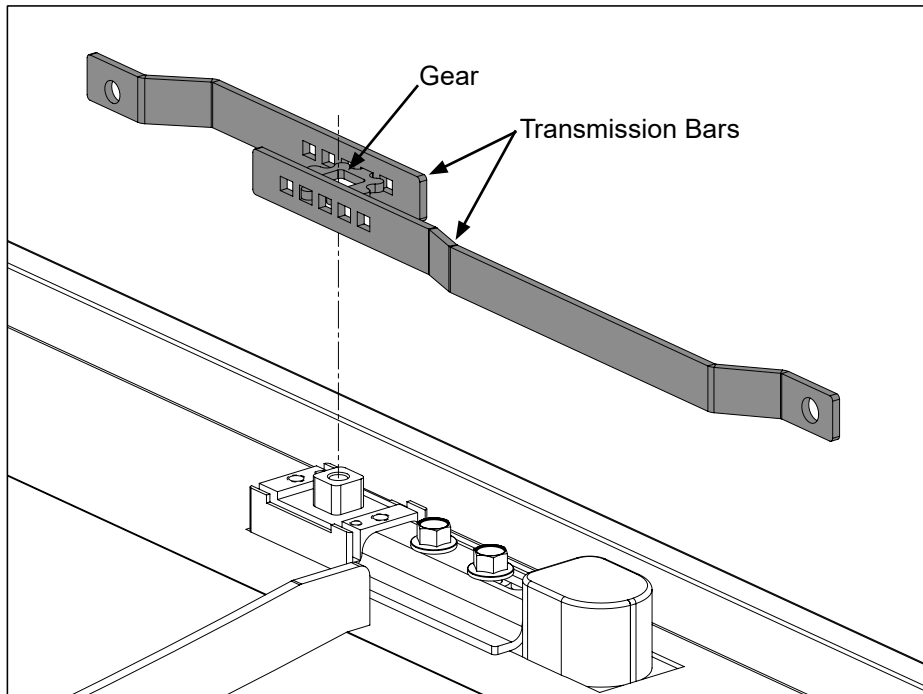

Lock Removal

- Remove (2) M5 10mm Hex Head Screws
- Remove Support Plate
- Remove Lock

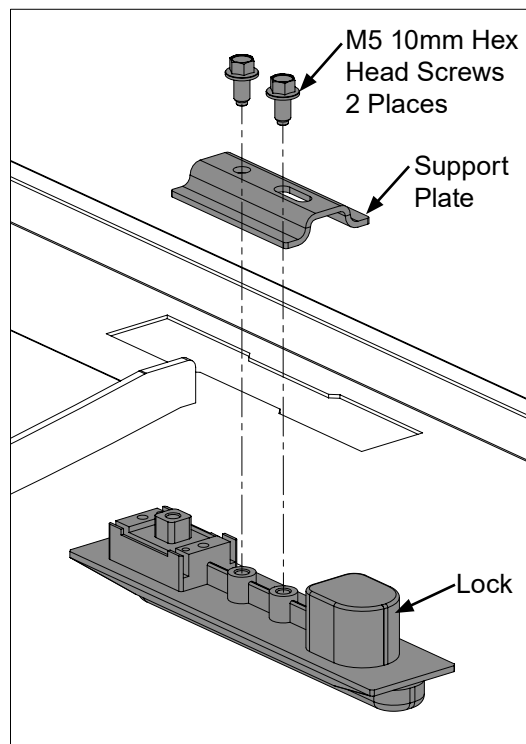

CCL3 Door Lock installation

- Dis-assemble support bracket, cam screw, phillips screws from CCL3 Lock
- Place support bracket on inside of door and CCL3 Lock on outside of door.
- Secure door lock to support bracket with phillips screws
- Fasten door handle cam assembly to door handle with Cam Screw

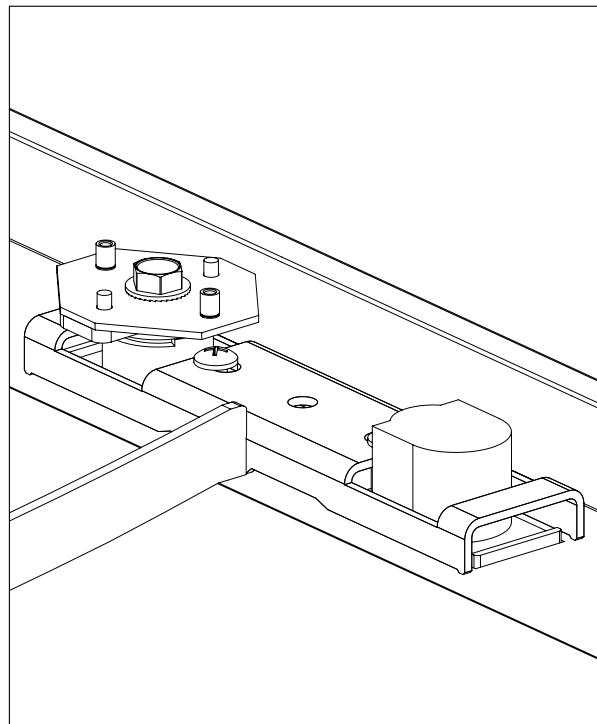
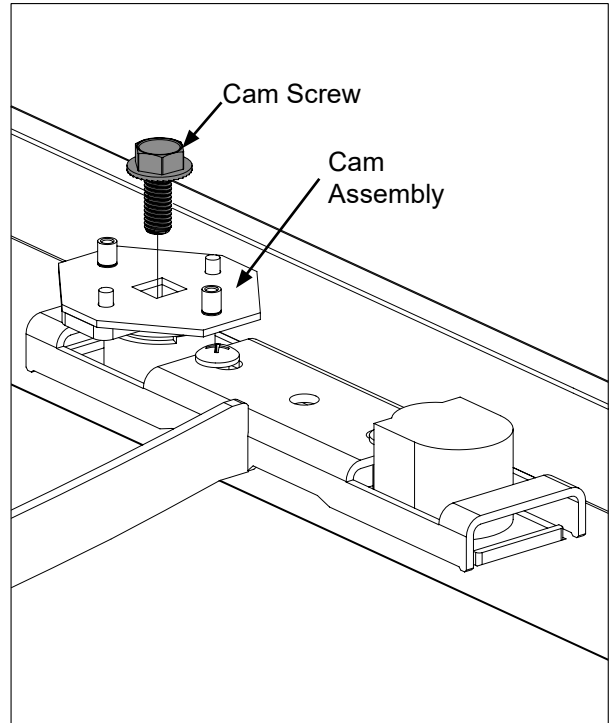
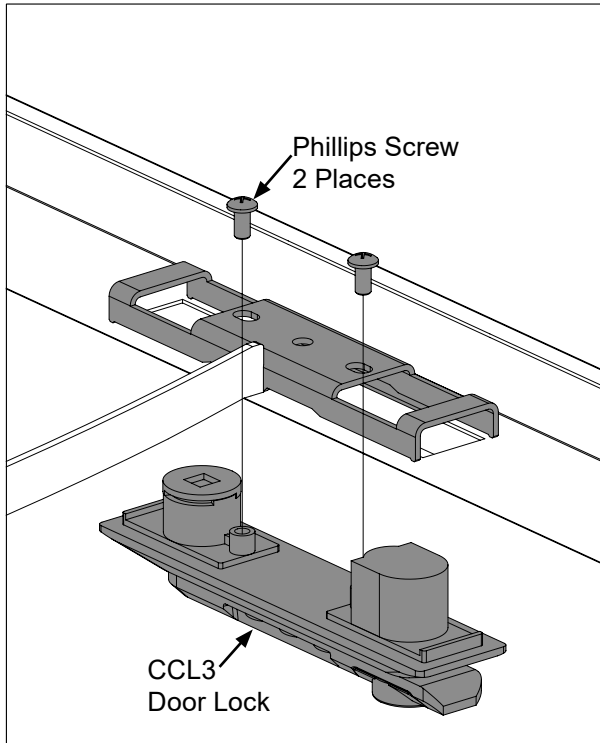

Lock Assembled

ACE02 Door Lock installation

- Assemble Top and Bottom Mounting Brackets to ACE02 Lock and Door using Mounting Screws
- Insert Stop Disk in proper orientation
- Fasten Cam Assembly to handle using Cam Screw

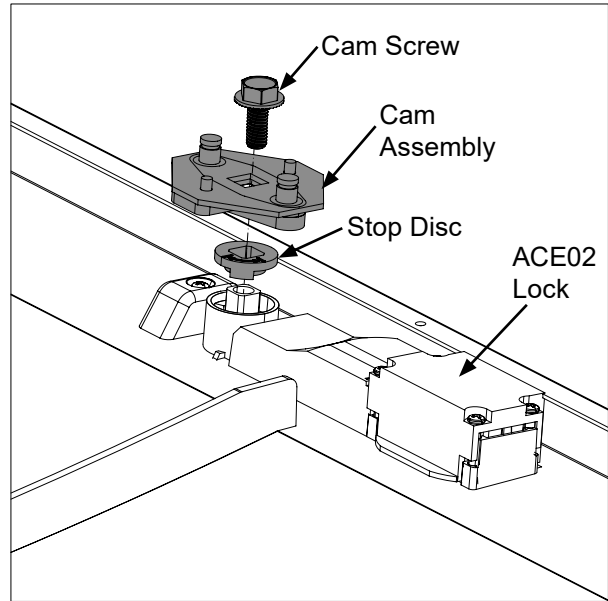
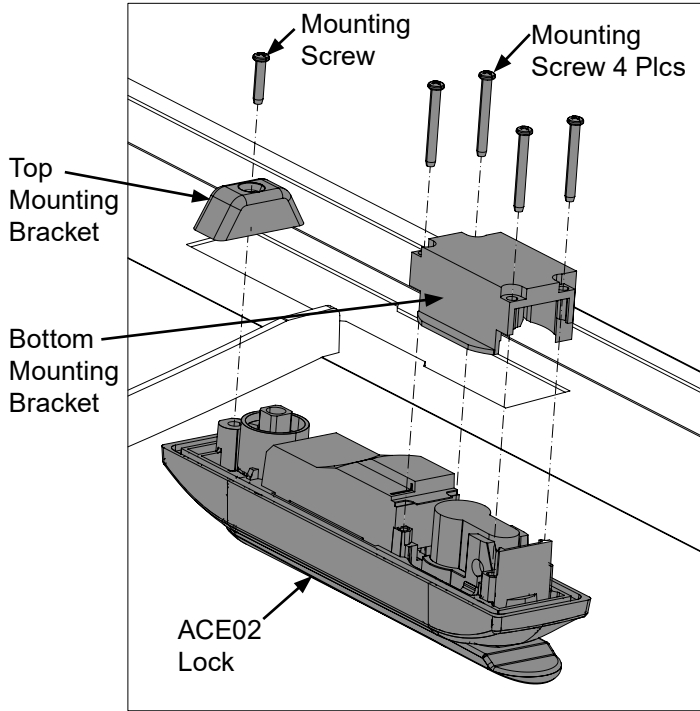

Front Door Rod installation

- Orient front door upper throw rod as shown and insert through bracket toward center of door
- Orient front door lower throw rod as shown and insert through bracket toward center of door

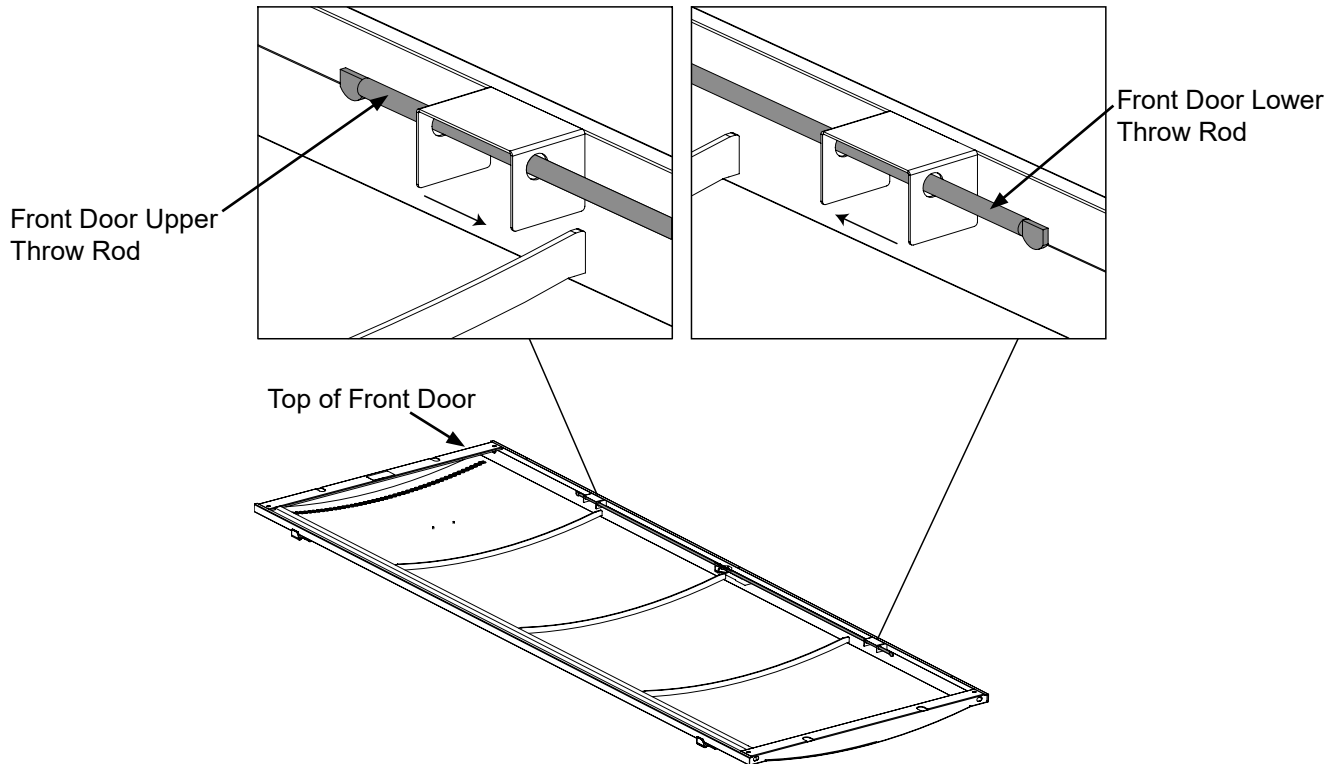

Rear Door Rod installation

- Orient rear door upper throw rod as shown and insert through bracket toward center of door
- Orient rear door lower throw rod as shown and insert through bracket toward center of door

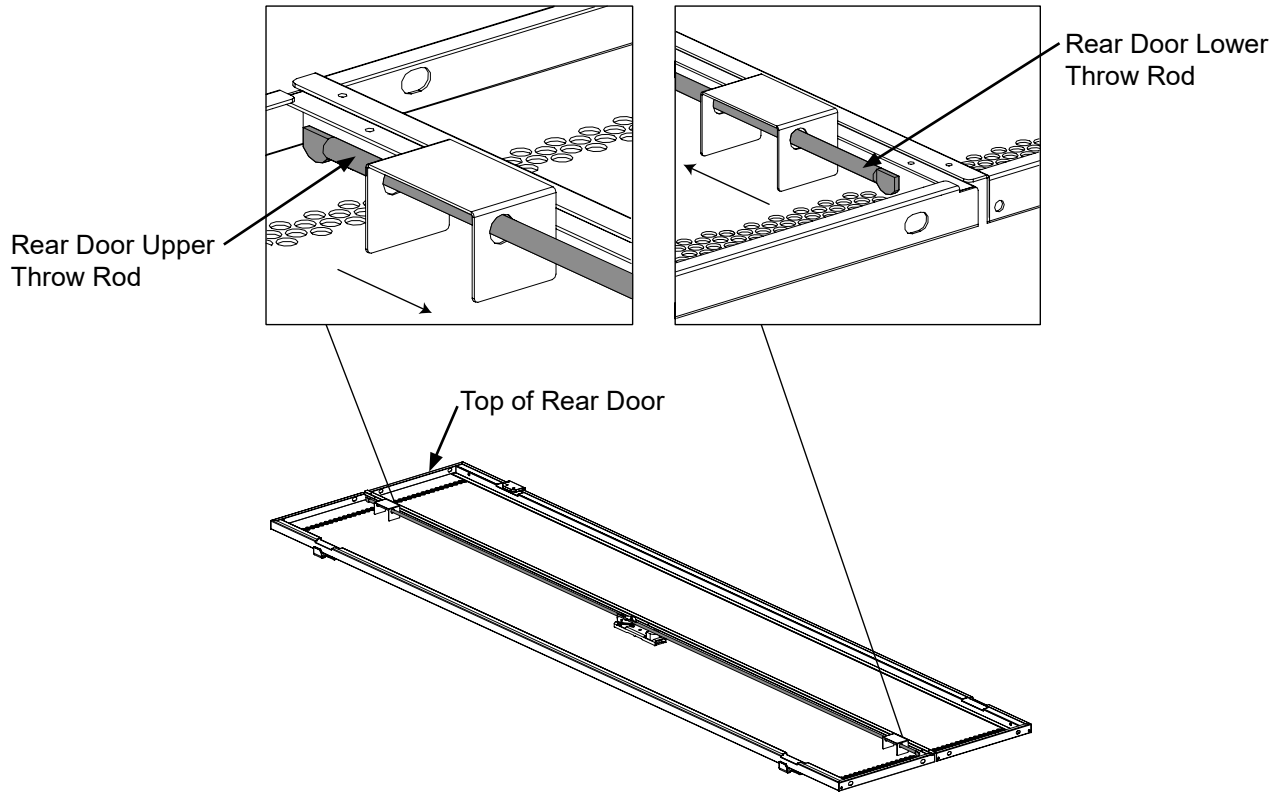

Fasten Door Rod to Cam Assembly

- Insert Upper and Lower Throw Rod on Door Handle Cam Assembly
- Fasten Throw Rods to Cam Assembly using (2) M3 x .5 x 6mm Pan Head Screws

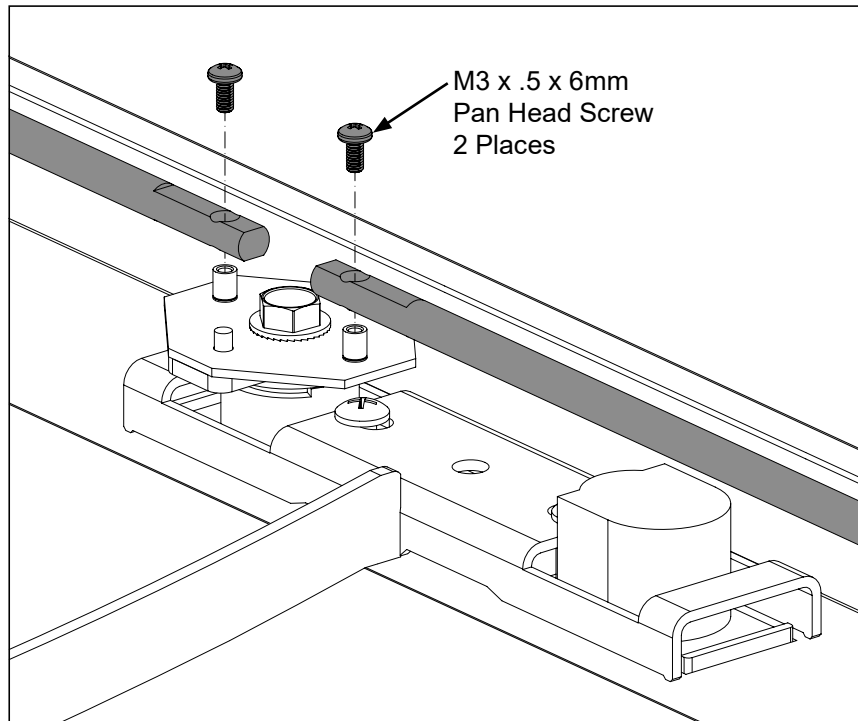

For Instructions in Local Languages
and Technical Support:

www.panduit.com/resources/install_maintain.asp

PANDUIT

www.panduit.com

E-mail:
techsupport@panduit.com

Phone:
866-405-6654