

THIS COPY IS PROVIDED ON A RESTRICTED BASIS AND IS NOT TO BE USED IN ANY WAY DETRIMENTAL TO THE INTERESTS OF PANDUIT CORP.

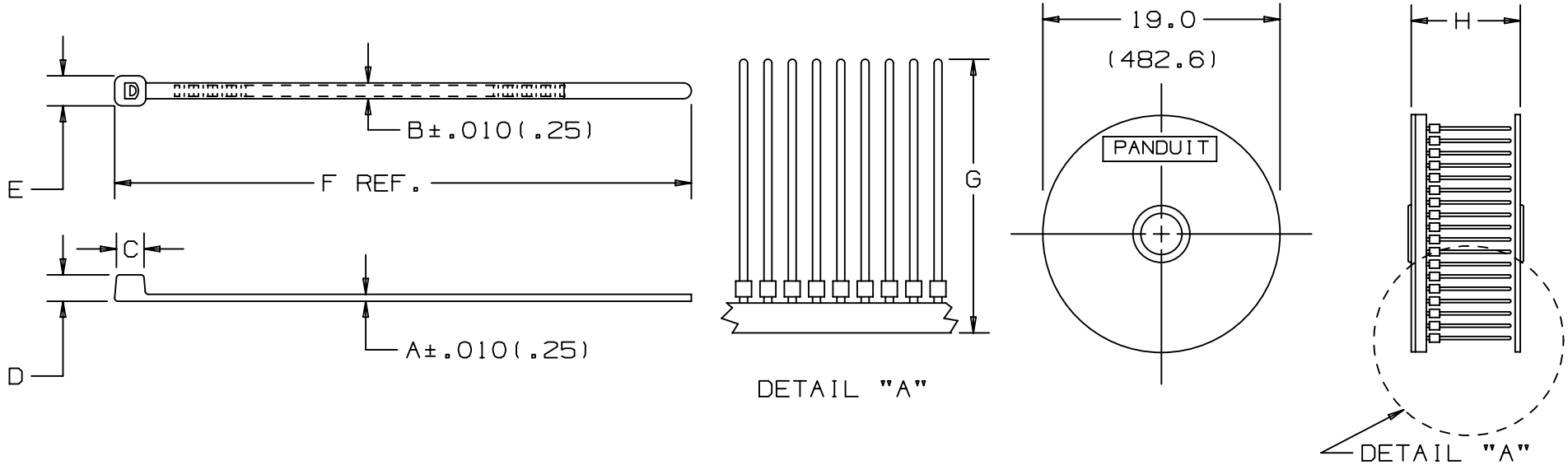

PANDUIT PART NO.*	BUNDLE DIA.		A IN. (mm)	B IN. (mm)	C IN. (mm)	D IN. (mm)	E IN. (mm)	F IN. (mm)	G IN. (mm)	H IN. (mm)	MINIMUM LOOP TENSILE lbs. (N)	CROSS SECTION	WEIGHT lbs. /100 pcs (g)
	MIN IN. (mm)	MAX IN. (mm)											
PLT2S-VMR	.06 (1.5)	1.94 (49.3)	.047 (1.2)	.190 (4.8)	.258 (6.6)	.220 (5.6)	.316 (8.0)	8.1 (206)	8.5 (216)	9.3 (236)	50 (222)	STANDARD	.32 (147)
PLT3S-VMR		2.75 (69.9)						11.3 (287)	11.8 (298)	12.5 (318)			.38 (174)

- NOTES:
- 1) SEE www.panduit.com FOR PART MATERIAL & COLOR SUFFIX DESIGNATIONS.
 - 2) STANDARD PACKAGING: 2500 STRAPS PER REEL; 2 REELS PER CARTON (2S); 1 REEL PER CARTON (3S)
 - 3) PACKAGED FOR USE WITH PAT2S AND PAT3S TOOLS AND DISPENSERS.
 - 4) LISTED UNDER THE COMPONENT PROGRAM OF UNDERWRITERS LABORATORIES INC.



TITLE													
VMR PREMIUM CABLE TIES PACKAGED FOR AUTOMATIC TOOLS													
CUSTOMER DRAWING													
ITEM REVISION NAME						W10030BY/03			PANDUIT				
DATASET FILE NAME						W10030BY/03							
UNLESS OTHERWISE SPECIFIED, DIMENSIONAL TOLERANCES ARE: IN [mm]									MATERIAL:				
.x ± .10 [2.5]						.xxx ± .020 [.51]			NYLON 6.6				
.xx ± .02 [.5]						ANGLES ± ---							
						THIRD ANGLE PROJECTION			DRAWING NUMBER:				
						SS-26588							
03	11-01-24	BDK	JADE	DJSL	A. UPDATED TITLE BLOCK WITH ALTERNATE DESCRIPTION				006205 r00				
REV	DATE	BY	CHK	APR	DESCRIPTION				ECN				
DRAWN BY						DATE		CHK		SCALE		SHT 1 OF 1	
RAM						4/8/92		HVP		NONE		A	

ANGLOBAL-ASIZE