

THIS COPY IS PROVIDED ON A RESTRICTED BASIS AND IS NOT TO BE USED IN ANY WAY DETRIMENTAL TO THE INTERESTS OF PANDUIT CORP.

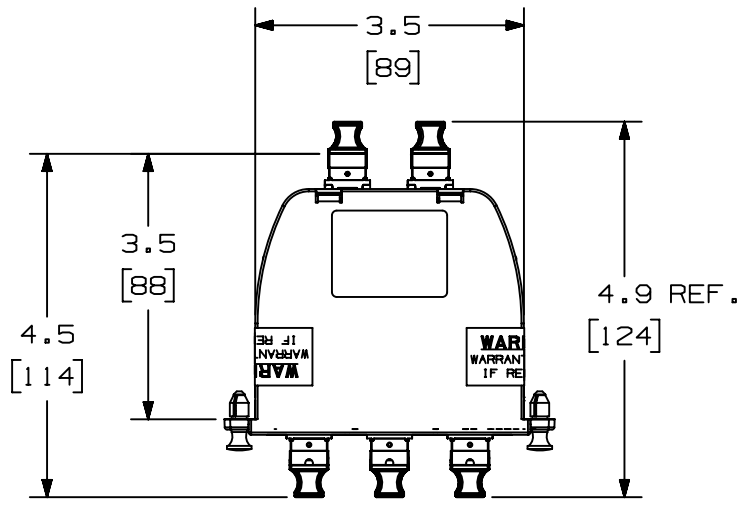

- NOTES:
1. SEE CURRENT CATALOG FOR PART NUMBER SUFFIXES.
 2. SEE CATALOG FOR COMPLETE LIST OF PARTS APPLICABLE FOR USE WITH THIS PRODUCT.
 3. PART NUMBERS: SEE SHEET 2
 4. REFER TO PANDUIT WEBSITE FOR 16-FIBER TO 12-FIBER APPLICATION GUIDE FOR LINK DESIGN.
 5. MATERIALS:
 - A. BOX AND LID: PLASTIC
 - B. ADAPTER: PLASTIC
 6. CASSETTE WEIGHT: 4.2oz [119g]
 7. DIMENSIONS IN BRACKETS ARE METRIC.

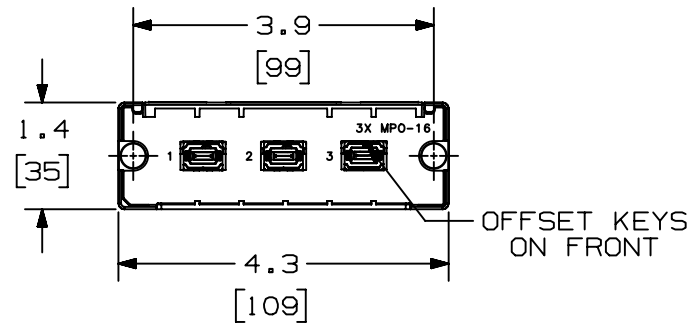

FRONT VIEW
SHOWN W/O DUSTCAPS

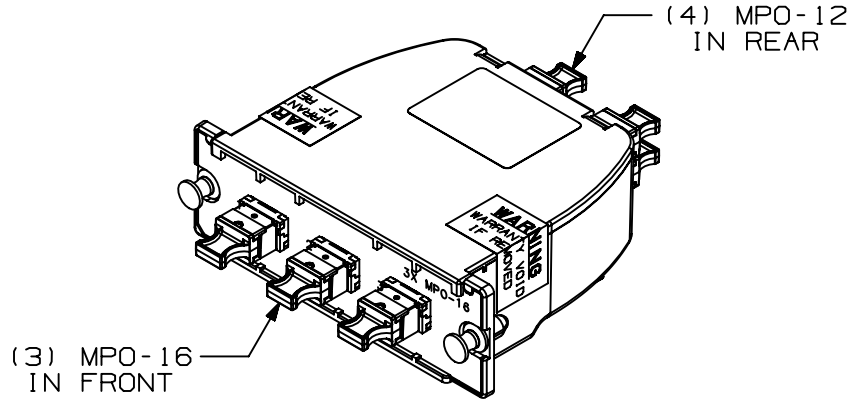

USAGE REQUIREMENTS

1. A CONVERSION CASSETTE IS REQUIRED AT EACH END OF THE LINK
2. RECOMMENDED FOR METHOD 'B' MPO12 LINKS ONLY

TITLE		OPTICOM 16F TO 12F CONVERSION CASSETTE ASSEMBLY					
CUSTOMER DRAWING		PANDUIT					
ITEM REVISION NAME	01302NAA/00			PART NO.	SEE SHEET 2		
DATASET FILE NAME	01302NAA-DC/00B	DRAWING NUMBER	01302NAA-DC				
UNLESS OTHERWISE SPECIFIED, DIMENSIONAL TOLERANCES ARE: IN [mm]		THIRD ANGLE PROJECTION					
.x ±	.xxx ± .010 [0.3]	DRAWN BY: SAT					
.xx ± .03 [0.8]	ANGLES ±	DATE: 09-28-23					
		CHK: SSP	SCALE: NONE				
REV	DATE	BY	DESCRIPTION	ECN	SHOWN W/O DUSTCAPS	SHT 1 OF 2	SIZE: A

00B	03-11-24	SSP	BJBE	MMN	ADD 'USAGE REQUIREMENTS' NOTES	V09002UD/03
00A	09-28-23	SAT	SSP	EJH	RELEASED TO PRODUCTION	V09002UD/02
REV	DATE	BY	CHK	APR	DESCRIPTION	ECN

THIS COPY IS PROVIDED ON A RESTRICTED BASIS AND IS NOT TO BE USED IN ANY WAY DETRIMENTAL TO THE INTERESTS OF PANDUIT CORP.

16-FIBER TO 12-FIBER CONVERSION CASSETTE	
PART NUMBER	DESCRIPTION
FC4ZO-48-463MU	(3) 16-FIBER TO (4) 12-FIBER CONVERSION CASSETTE OM4 FIBER (50/125um); OPTIMIZED LOSS; MALE MPO-16 TO MALE MPO-12; U CONNECTIVITY
FC4ZN-48-463MU	(3) 16-FIBER TO (4) 12-FIBER CONVERSION CASSETTE OM4 FIBER (50/125um); STANDARD LOSS; MALE MPO-16 TO MALE MPO-12; U CONNECTIVITY
FC49N-48-463MU	(3) 16-FIBER TO (4) 12-FIBER CONVERSION CASSETTE OS2 FIBER (9/125um); STANDARD LOSS; MALE MPO-16 TO MALE MPO-12; U CONNECTIVITY

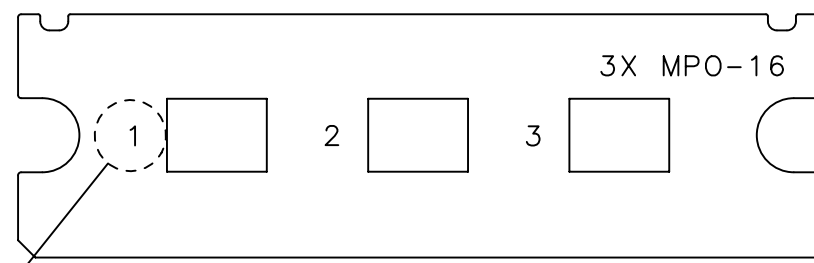

PORT IDENTIFICATION

TITLE		OPTICOM 16F TO 12F CONVERSION CASSETTE ASSEMBLY	
		CUSTOMER DRAWING	
ITEM REVISION NAME		01302NAA/00	
DATASET FILE NAME		01302NAA-DC/00B	
UNLESS OTHERWISE SPECIFIED, DIMENSIONAL TOLERANCES ARE: IN [mm]		PANDUIT	
.x ± .xxx ± .010 [0.3]			
.xx ± .03 [0.8]		PART NO. SEE TABLE	
ANGLES ±			
		DRAWING NUMBER: 01302NAA-DC	
DRAWN BY	DATE	CHK	SCALE
SAT	09-28-23	SSP	NONE
SEE SHEET 1 FOR REVISION HISTORY		SHT 2 OF 2	

REV	DATE	BY	CHK	APR	DESCRIPTION	ECN