

THIS COPY IS PROVIDED ON A RESTRICTED BASIS AND IS NOT TO BE USED IN ANY WAY DETRIMENTAL TO THE INTERESTS OF PANDUIT CORP.

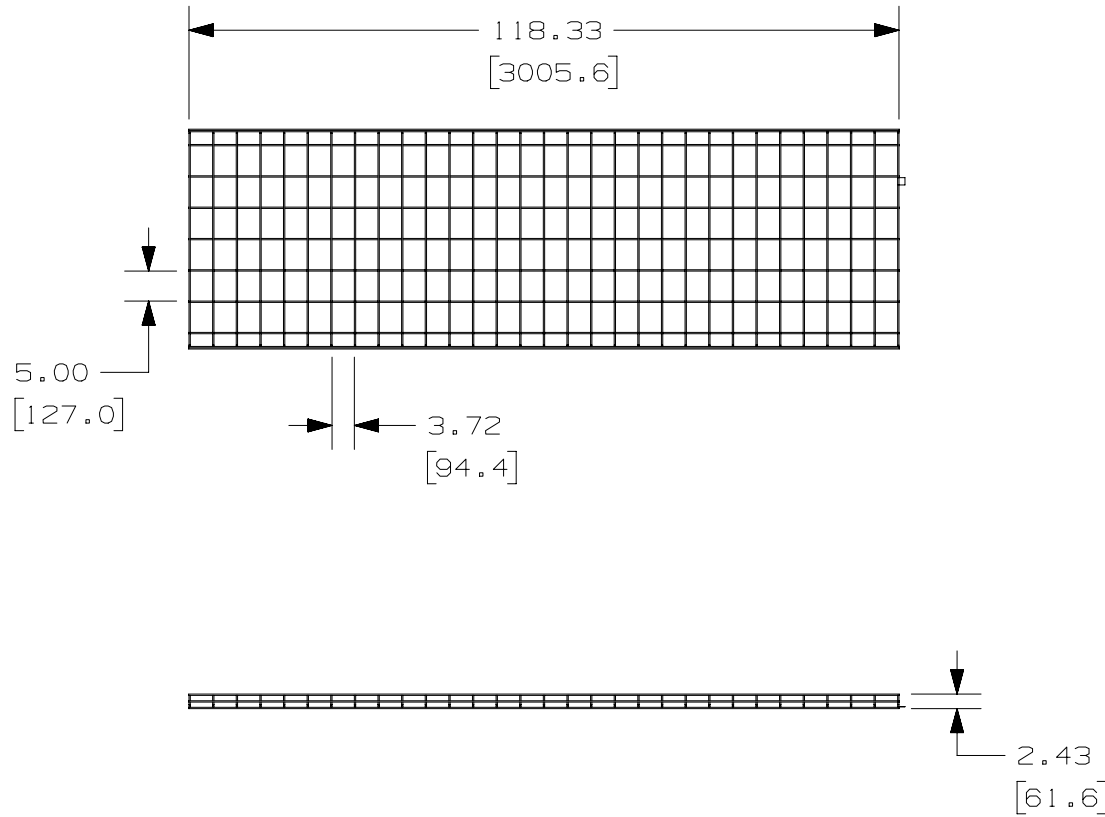

PANDUIT PART NUMBER	WEIGHT
PWB2X36**	26.8 LB/EACH 12156 g/EACH

NOTES:

- SEE CURRENT CATALOG FOR ADDITIONAL PART SUFFIXES TO INDICATE PART FINISH AND/OR PACKAGING QUANTITY.
- DIMENSIONS IN PARENTHESIS ARE METRIC.

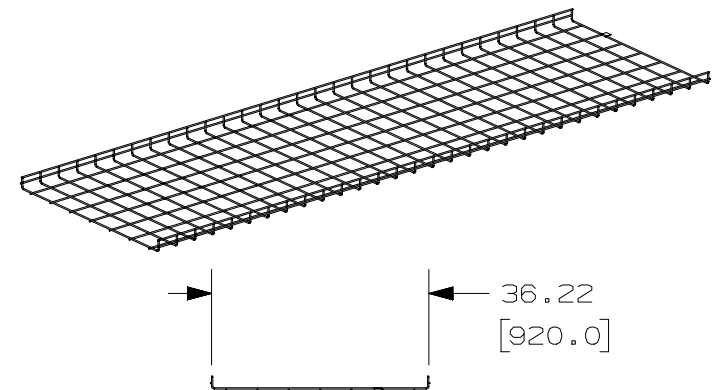

TITLE PANDUIT WIRE BASKET 2" (50mm) SIDEWALL X 36" (900mm) WIDE STRAIGHT SECTION 10' LONG CUSTOMER DRAWING					
ITEM REVISION NAME 03154NAN/00				PANDUIT	
DATASET FILE NAME 03154NAN_DC/00A					
UNLESS OTHERWISE SPECIFIED, DIMENSIONAL TOLERANCES ARE: IN [mm]				MATERIAL: SEE NOTES ABOVE	
.X ± .19 [4.83] .XXX ± .XX ± .19 [4.83] ANGLES ±				DRAWING NUMBER: 03154NAN-DC	
 THIRD ANGLE PROJECTION				SHT 1 OF 1	
REV	DATE	BY	CHK	APR	DESCRIPTION
00A	11/15/2024	MES	JSP	JAWI	INITIAL RELEASE
					ECN
					V09003BZ/00
					MES
					11/15/2024
					JSP
					NONE
					A

D10100DA/15

2

1

2

1