

THIS COPY IS PROVIDED ON A RESTRICTED BASIS AND IS NOT TO BE USED IN ANY WAY DETRIMENTAL TO THE INTERESTS OF PANDUIT CORP.

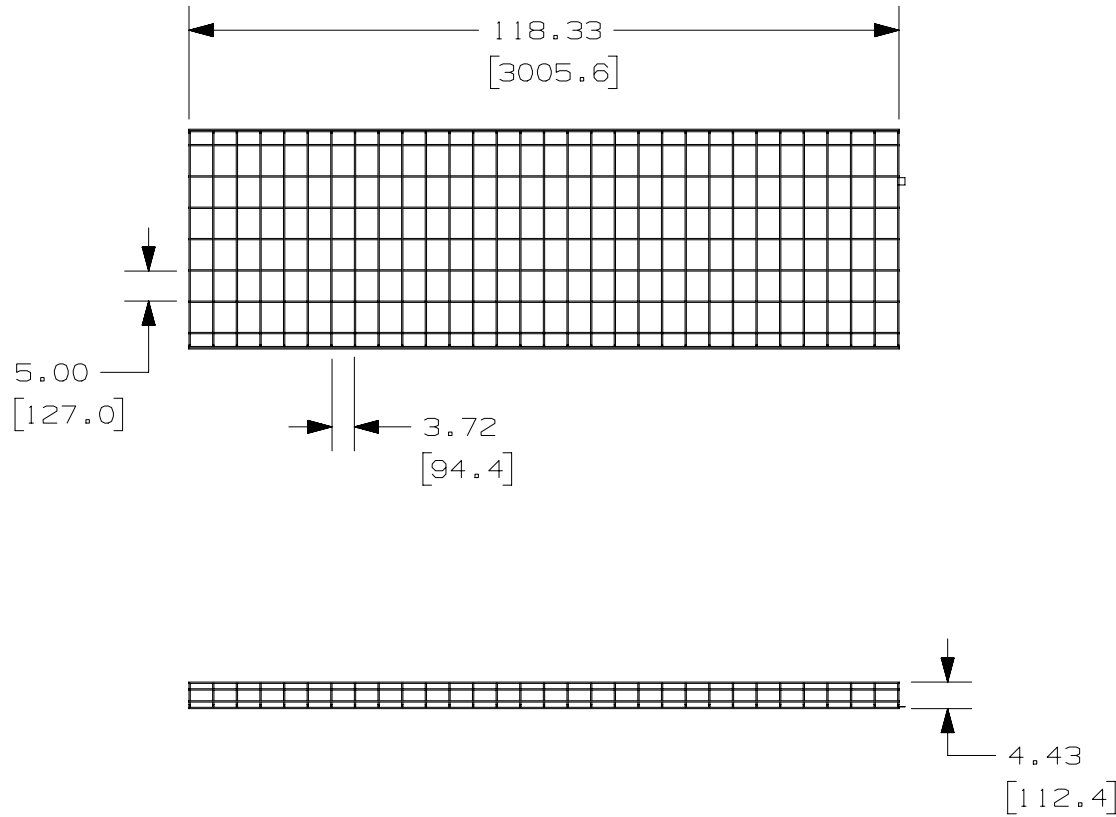

PANDUIT PART NUMBER	WEIGHT
PWB4X36**	30.7 LB/EACH 13925 g/EACH

NOTES:

- SEE CURRENT CATALOG FOR ADDITIONAL PART SUFFIXES TO INDICATE PART FINISH AND/OR PACKAGING QUANTITY.
- DIMENSIONS IN PARENTHESIS ARE METRIC.

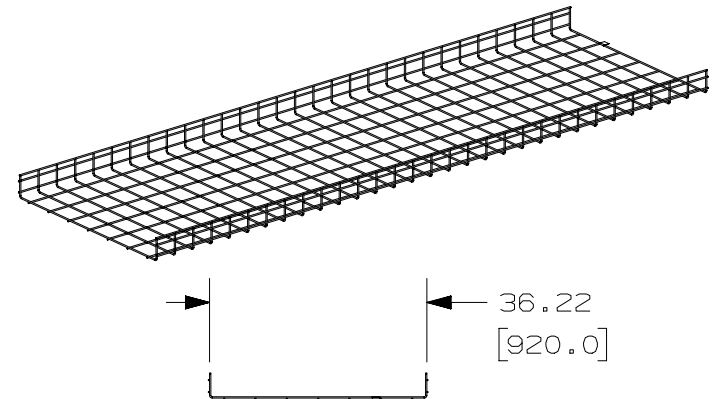

TITLE PANDUIT WIRE BASKET 4" (100mm) SIDEWALL X 36" (900mm) WIDE STRAIGHT SECTION 10' LONG CUSTOMER DRAWING					
ITEM REVISION NAME 03154NAP/00				<b>PANDUIT</b>	
DATASET FILE NAME 03154NAP_DC/00A					
UNLESS OTHERWISE SPECIFIED, DIMENSIONAL TOLERANCES ARE: IN [ mm ] .X ± .XXX ± .XX ± .19 [ 4.83 ] ANGLES ±				MATERIAL: SEE NOTES ABOVE	
DRAWING NUMBER: 03154NAP-DC				DRAWING NUMBER: 03154NAP-DC	
THIRD ANGLE PROJECTION					
DRAWN BY MES	DATE 11/15/2024	CHK JSP	SCALE NONE	SHT 1 OF 1	SIZE A

00A	11/15/2024	MES	JSP	JAWI	INITIAL RELEASE	V09003BZ/00
REV	DATE	BY	CHK	APR	DESCRIPTION	ECN

D10100DA/15