

F

THIS COPY IS PROVIDED ON A RESTRICTED BASIS AND IS NOT TO BE USED IN ANY WAY DETRIMENTAL TO THE INTERESTS OF PANDUIT CORP.

PART NUMBER	MATERIAL	PACKAGE QUANTITY
MMP350HW54-MAL	5005 ALUMINUM	1000

NOTES:

- BRACKETS [] DENOTES DIMENSIONS IN MILLIMETERS.
- CUSTOM PERMANENT MARKING AVAILABLE. CONSULT FACTORY.
- TOLERANCE (UNLESS OTHERWISE SPECIFIED)
 .xxx = +/- .020 [.51]
 .xx = +/- .03 [.8]
- USE WITH HEAVY CROSS SECTION STAINLESS STEEL CABLE TIE, MLT*H. SEE N41115BS_DC.

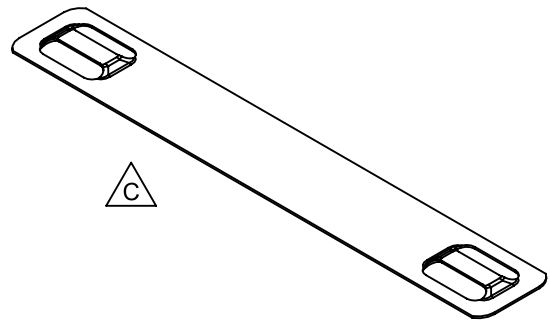
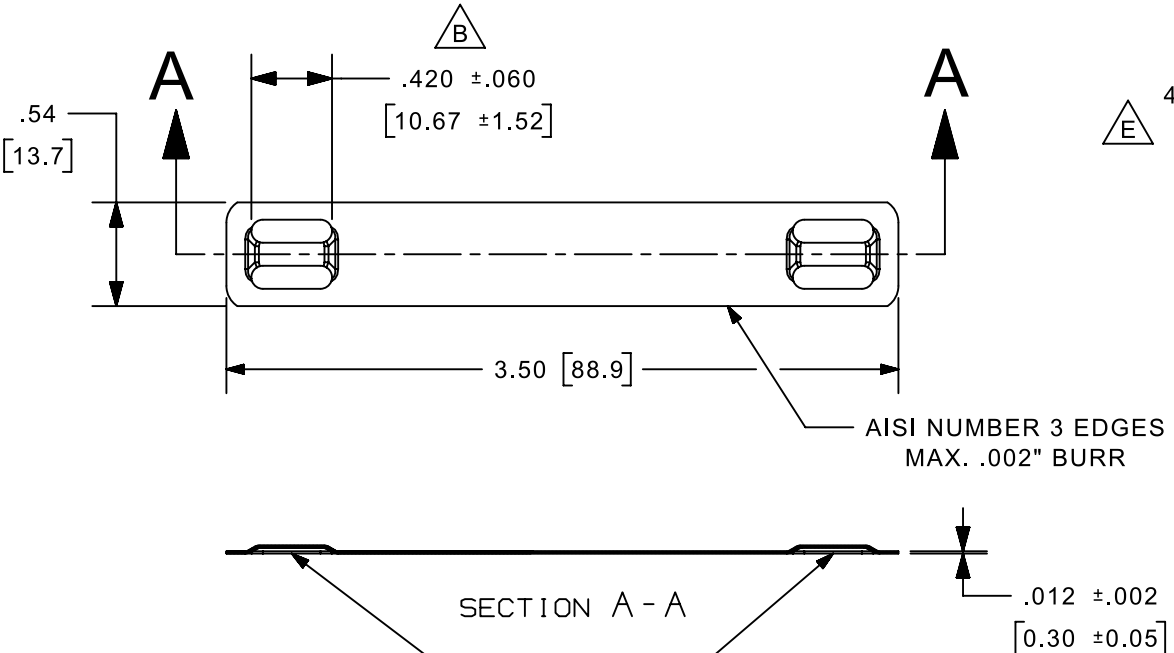

SEE NOTE 4.

PART NUMBER		MMP350HW54-MAL		
TITLE		MMP350HW54-MAL 1/2" ALUMINUM MARKER PLATE-HEAVY CUSTOMER DRAWING		
ITEM REVISION NAME		N41664BS/01		
DATASET FILE NAME		N41664BS_DC/01A		
MATERIAL		ALUMINUM		
DRAWN BY		DATE	CHK	SCALE
JAMB		1/26/09	EJD	FULL & NOTED
DRAWING NUMBER		N41664BS_DC		
SHEET 1 OF 1		A		

01A	7/10/2025	RVU	ANRO	MSAD	F. REMOVED 1 ST TABLE, NOT TO SHOW CUSTOMER NAME, APPROVAL AND DATE. E. ADDED NOTE 4. D. ERROR TYPO, N41664BS_DC WAS S41664BS_DC. C. ADDED 3-D ISO VIEW. B. ADDED DIM. .42" +/- .060 WIDTH. A. RECREATED DRAFTING CUSTOMER DRAWING W/ NEW TEMPLATE.	GAECN07410
00A	1/26/10	EJD	EJD	PM	DRAWING RELEASE.	ECN00648
REV	DATE	BY	CHK	APR	DESCRIPTION	ECN

A-SIZE_CUSTOMER_LAND