

THIS COPY IS PROVIDED ON A RESTRICTED BASIS AND IS NOT TO BE USED IN ANY WAY DETRIMENTAL TO THE INTERESTS OF PANDUIT CORP.

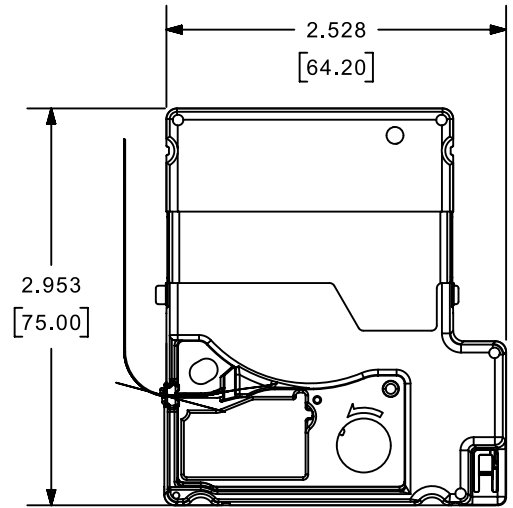

PART NO.	MATERIAL	COLOR	'A'	'B'	CASSETTE LABELS PER ROLL	WIRE DIAMETER RANGE	COMPATIBLE PRINTER
F100X150AJM	GM Y16	WHITE	0.75 [19.1]	0.75 [19.1]	150	0.12" - 0.20"	MP300

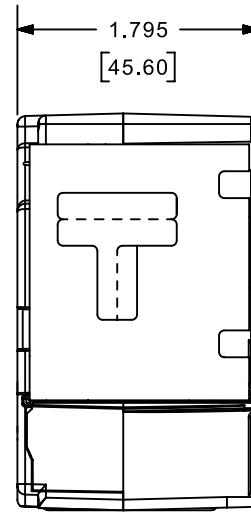
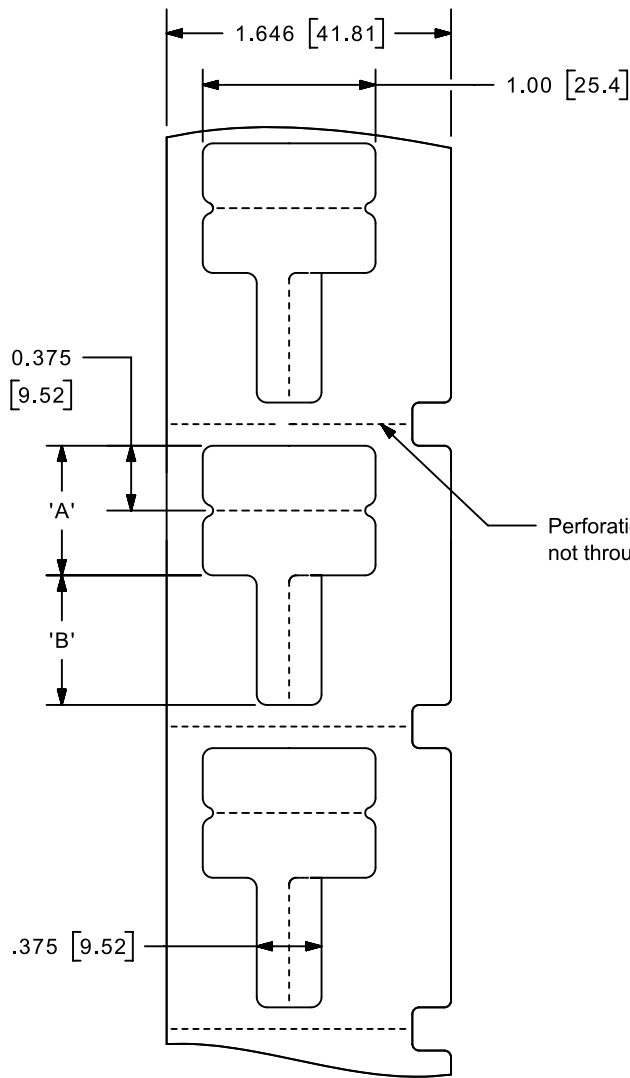

03A	9/5/2025	RVU	DAJ	MSAD	A. CHANGED MATERIAL FROM GMY4-HT TO GMY16.	GAECN07299
01C	10/13/2023	RVU	JSUN	MSAD	A. 150 WAS 130.	GAECN06921
01B	8/21/2023	RVU	JSUN	MSAD	E. CHANGED TITLE FROM MP TO PXE. D. ADDED PERF. NOTE. C. ADDED WIRE DIAMETER RANGE, 0.12" - 0.20". B. UPDATED TABLE. A. 130 WAS 150.	GAECN06843
01A	9/2/2022	RVU	DAPE	MSAD	ADDED NEW PERFORATION ON THIS FLAG.	GAECN06595
00A	5/28/2020	RVU	RCMC	JHAC	DRWING RELEASE.	GAECN04944

REV	DATE	BY	CHK	APR	DESCRIPTION	ECN

TITLE						
FLAG LABEL PXE CASSETTE						
CUSTOMER DRAWING						
ITEM REVISION NAME					PANDUIT	
100743X0/03						
DATASET FILE NAME					MATERIAL: SEE TABLE	
100743X0_DC/03A CUST DWG						
UNLESS OTHERWISE SPECIFIED, DIMENSIONAL TOLERANCES ARE: IN [mm]						
.x ± .1 [2.54]			.xxx ± .025 [.635]		DRAWING NUMBER: I00743X0_DC	
.xx ± .05 [1.27]			ANGLES ±			
			THIRD ANGLE PROJECTION			
DRAWN BY	DATE	CHK	SCALE			
RVU	4/12/19	JHAC	NTS			
				SHT 1 OF 1	A	

D10100DA/20