

Part numbers needed to create Wall Termination Bracket:

PWBWMW**= Wall termination Bracket, Wide
PWBWMN**= Wall termination Bracket, Narrow
PWBHK**= Hardware Kit (Sold Separately)
Customer supplied fasteners (Not included)
Two brackets included

Load on PWBWMN** not exceed 200 lbs. per bracket.
Load on PWBWMW** not to exceed 250 lbs per bracket.

Wall Termination Brackets accepts up to 3/8" or 10mm customer supplied hardware.

*Specific applications or load conditions can vary and may require additional supports or placement adjustments to accommodate actual installation needs.

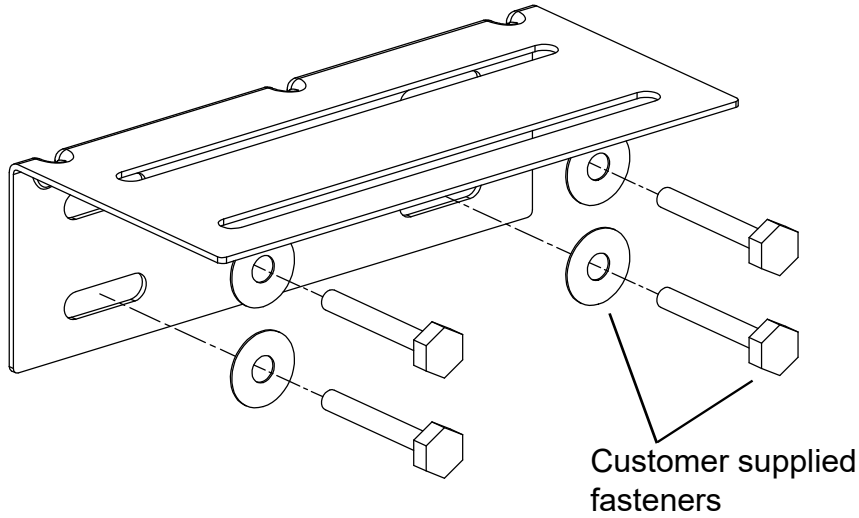

BASKET WIDTH	P/N TO USE	BRACKET QTY REQUIRED	PWBHK** REQUIRED
4"	PWBWMN**	1	4
6"	PWBWMW**	1	4
8"	PWBWMW**	1	4
12"	PWBWMN**	2	8
18"	PWBWMW**	2	8
24"	PWBWMW**	2	8

Hardware not included. See PWBHK** for hardware.

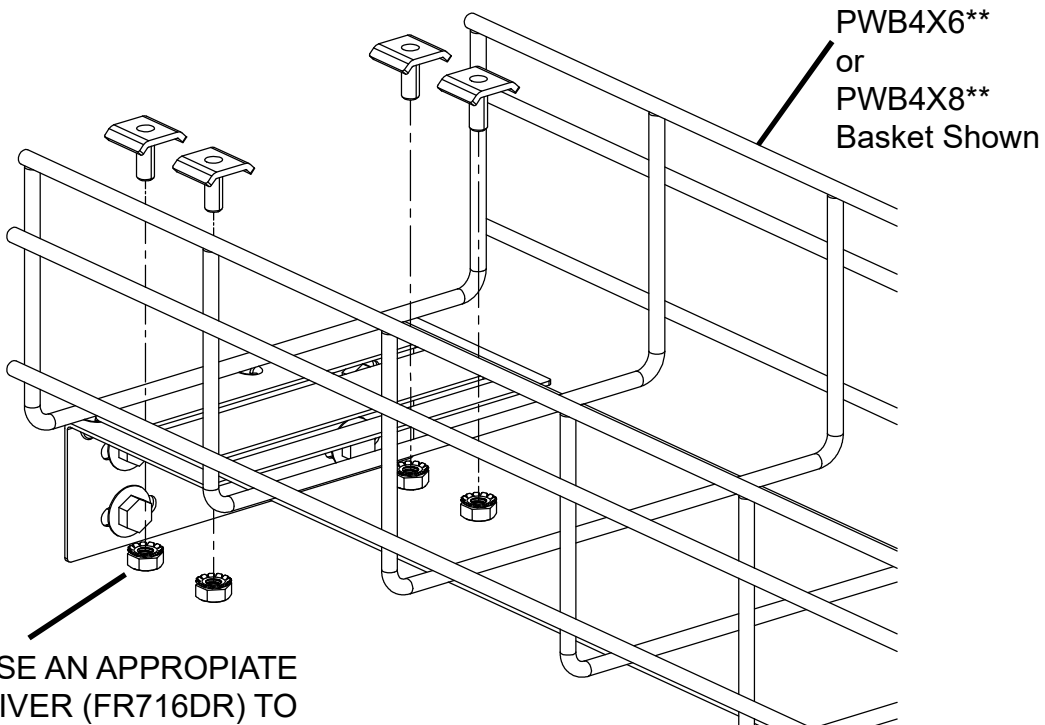

7/16" NUT - USE AN APPROPRIATE 7/16" NUT DRIVER (FR716DR) TO TIGHTEN FASTENERS.

For Technical Support: www.panduit.com/resources/install_maintain.asp

