

PS21L



Fins de course en boîtier de 30mm



Principales caractéristiques

- Boîtier métallique ou plastique de 30mm
- Contacts à action lente et à action rapide
- Contacts en option : 1NO+1NF, 2NF, 2NO, 1NO+1NF avec chevauchement
- Contacts de type Zb
- Fonctionnement des contacts à ouverture forcée \ominus (EN 60947-5-1)
- Double isolation \square (type plastique)
- Indice de protection IP65 ou IP66

Applications

Ils servent à surveiller la position et la limite de déplacement, le passage et le comptage d'objets.

Types d'entrée de câble et de connecteur



Presse-étoupe



Connecteur DT04



Connecteur M12

Dimensions

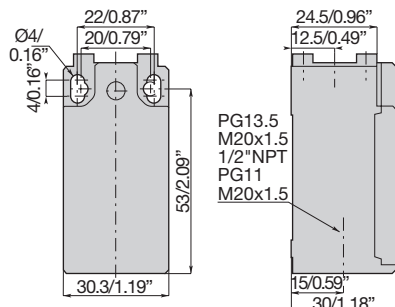

Fig. 1 PS21L-A/B/M/N/P en boîtier plastique

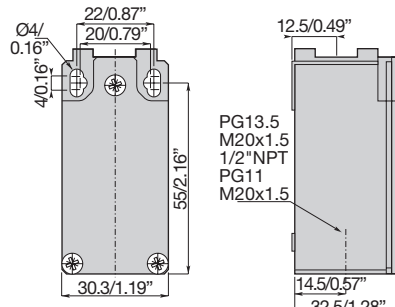

Fig. 2 PS21L-A/B/M/N/P en boîtier métallique

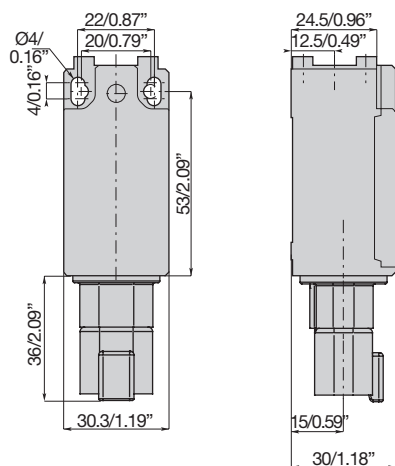

Fig. 3 PS21L-D en boîtier plastique

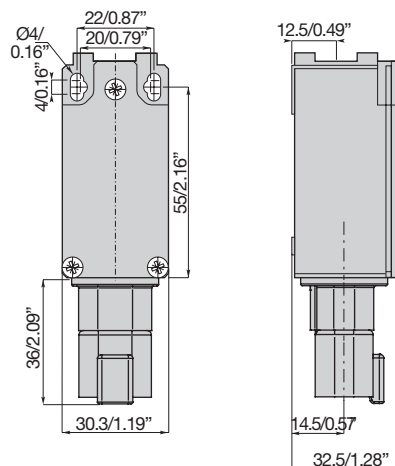

Fig. 4 PS21L-D en boîtier métallique

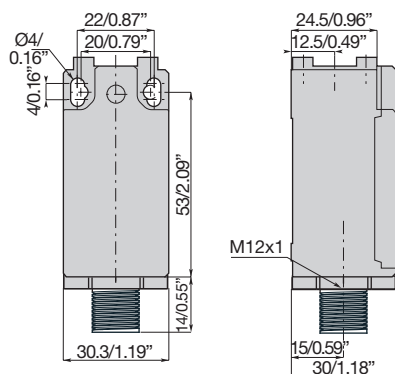

Fig. 5 PS21L-M1 en boîtier plastique

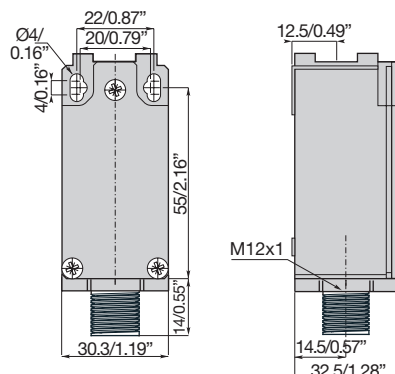
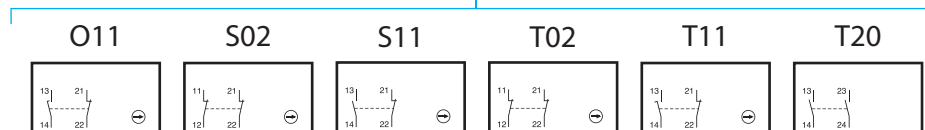

Fig. 6 PS21L-M1 en boîtier métallique

Nomenclature - Boîtier plastique



PS21L - **a** **bbb** **cc** - **d** 00



a: raccord par câble **bbb:** type de contact **cc:** type d'actionneur **d:** matériau du boîtier

Codification

PS21L - - 00

Code	Option	Description
PS21L	-	Fin de course, largeur 30mm
<input type="checkbox"/>	-	Entrée de câble
	A	M16
	B	PG11
	D	Connecteur DT04
	M	M20
	M1	Connecteur M12
	N	1/2 NPT
	P	PG13.5
<input type="checkbox"/>	-	Type de contact
	O11	1NO+1NF à chevauchement lent (+)
	S02	2NF à action rapide (+)
	S11	1NO+1NC à action rapide (+)
	T02	2NF à action lente (+)
	T11	1NO+1NF à action lente (+)
	T20	2NO à action lente
<input type="checkbox"/>	-	Type d'actionneur
	BE	Galet nylon, levier coudé vers l'extérieur
	BR	Galet nylon, levier coudé vers l'intérieur
	LA	Levier réglable Ø3, inox
	LB	Actionneur nylon avec ressort inox
	LG	Levier réglable Ø6, fibre de verre
	LO	Poussoir acier avec galet nylon + joint
	LP	Actionneur multidirectionnel nylon avec ressort inox
	LS	Actionneur multidirectionnel avec ressort inox
	LW	Actionneur multidirectionnel avec ressort inox (tige souple)
	N6	Commande par câble
	P0	Poussoir métallique lisse
	PH	Poussoir métallique + joint
	PR	Poussoir métallique à galet
	R1	Levier réglable avec galet nylon
	RH	Levier avec galet plastique sur poussoir métallique (à gauche)
	RT	Levier avec galet nylon
	RV	Levier avec galet plastique sur poussoir métallique (à droite)
	W0	Levier avec galet caoutchouc Ø50
	W1	Levier réglable avec galet caoutchouc Ø50
<input type="checkbox"/>	-	Matériau du boîtier
	H	Boîtier plastique et tête métallique
	T	Boîtier plastique et tête plastique
00	-	Sans option

Nomenclature - Boîtier métallique

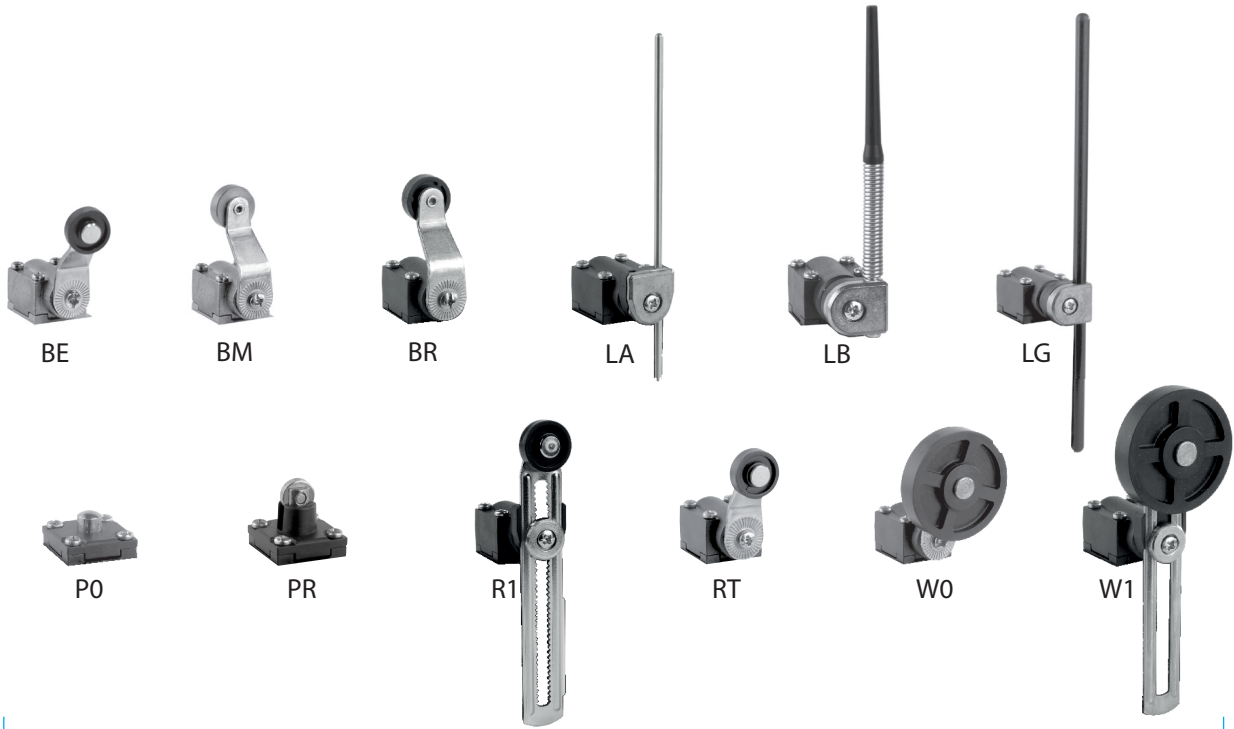

PS21L - **a** **bbb** **cc** - **d** 00

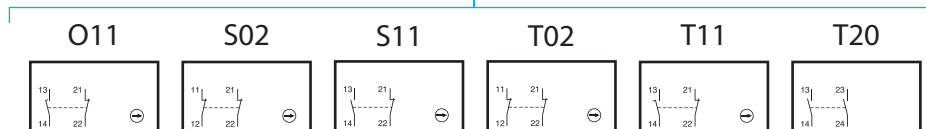

a: raccord par câble **bbb:** type de contact **cc:** type d'actionneur **d:** matériau du boîtier

 Codification
PS21L - - M 00

Code	Option	Description
PS21L	-	Fin de course, largeur 30mm
<input type="checkbox"/>	-	Entrée de câble
	A	M16
	B	PG11
	D	Connecteur DT04
	M	M20
	M1	Connecteur M12
	N	1/2 NPT
	P	PG13.5
<input type="checkbox"/>	-	Type de contact
	O11	1NO+1NF à chevauchement lent (+)
	S02	2NF à action rapide (+)
	S11	1NO+1NC à action rapide (+)
	T02	2NF à action lente (+)
	T11	1NO+1NF à action lente (+)
	T20	2NO à action lente
<input type="checkbox"/>	-	Type d'actionneur
	BE	Galet nylon, levier coudé vers l'extérieur
	BM	Levier coudé à galet métallique
	BR	Galet nylon, levier coudé vers l'intérieur
	LA	Levier réglable Ø3, inox
	LB	Actionneur nylon avec ressort inox
	LG	Levier réglable Ø6, fibre de verre
	P0	Poussoir métallique lisse
	PR	Poussoir métallique à galet
	R1	Levier réglable avec galet nylon
	RT	Levier avec galet nylon
	W0	Levier avec galet caoutchouc Ø50
	W1	Levier réglable avec galet caoutchouc Ø50
M	-	Boîtier métallique et tête métallique
00	-	Sans option

Caractéristiques

Caractéristiques électriques

		PS21L - xxx - H or T	PS21L - xxx - M
Courant nominal de fonctionnement IEC 60947-5-1			
Ie/CA-15	24Vca - 50/60Hz	10 A	10 A
	240Vca - 50/60Hz	6 A (contacts S02 3 A)	6 A (contacts S02 3 A)
	400Vca - 50/60Hz	4 A	4 A
Ie/CC-13	24Vcc	6 A	6 A
	125Vcc	0,55 A	0,55 A
	250Vcc	0,4 A	0,4 A
Courant nominal de fonctionnement UL 508, CSA C22-2 n°14			
	Caractéristiques CA	A 600	A 300
	Caractéristiques CC	Q 600	Q 300
Tension d'isolation nominale Ui IEC 60947-5-1		500V (versions S02 Ui=400 V)	500V (versions S02 Ui=400 V)
Tension d'isolation nominale Ui UL 508, CSA C22-2 n°14		A 600, Q 600	A 300, Q 300
Tension nominale d'impulsion supportée Uimp IEC 60947-5-1/EN 60947-5-1		6 kV	6 kV
Courant thermique Ith - q < 40°C/104°F IEC 60947-5-1/EN 60947-5-1		10 A	10 A
Durabilité électrique IEC 60947-5-1			
Fréquence de commutation max.		3600 cycles/h	3600 cycles/h
Facteur de charge		0,5	0,5
Nombre de manœuvres max.		Se référer aux diagrammes des catégories d'utilisation CA-15 et CC-13	
Protection contre les courts-circuits Fusibles de type gG		10 A	10 A
Protection contre les chocs électriques - IEC 536		Classe II	Classe II

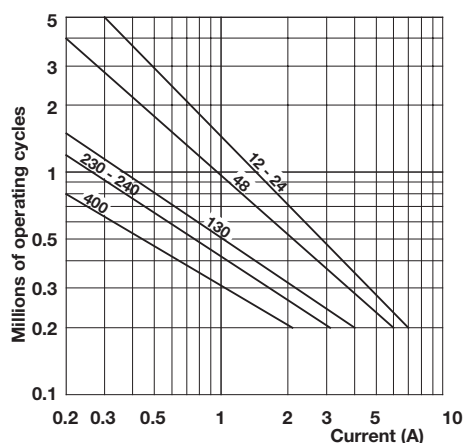

Fig. 7 Diagramme pour contact à action rapide

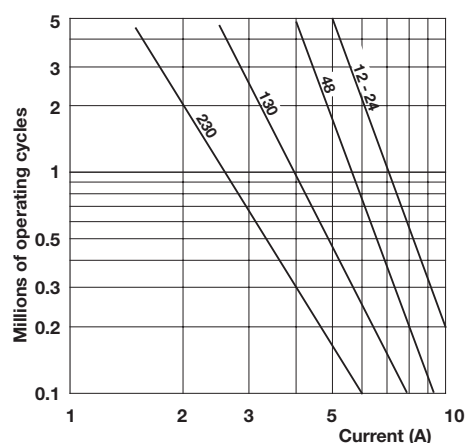

Fig. 8 Diagramme pour contact à action lente

Durabilité électrique pour la catégorie d'utilisation CC-13

Puissance de commutation pour une durabilité de 5 millions de cycles:

Tension	Action rapide	Action lente
24V	9.5W	12W
48V	6.8W	9W
110V	3.6W	6W





Caractéristiques mécaniques

	PS21L - xxx - T	PS21L - xxx - H	PS21L - xxx - M
Matériau du boîtier	Plastique	Plastique	Métallique
Matériau de la tête de l'actionneur	Plastique	Métallique	Métallique
Poids	≥ 70g	≥ 75g	≥ 180g
Câblage Versions avec presse-étoupe A, B, M, N, P			
Bornes à vis	Vis M3,5 (+,-) pozidriv 2 avec serre-câble		
Spécifications des fils	0,5 mm ² ÷ 2,5 mm ² - AWG 20 ÷ AWG 14		
Marquage des bornes à vis	selon IEC 60947-5-1		

Environnement

	PS21L - xxx - T	PS21L - xxx - H	PS21L - xxx - M
Température de fonctionnement	-25° à +70°C (-13° à +158°F)		
Température de stockage	-30° à +80°C (-22° à +176°F)		
Résistance au choc IEC 68-2-27 et EN 60068-2-27	50g/1.76oz (25g/0.88oz pour actionneurs de types W0 et W1) (choc semi-sinusoidal pour 11ms) pas de changement de position de contact		
Résistance aux vibrations IEC 68-2-6 et EN 60068-2-6	25g/0.88oz (10...500Hz) pas de changement de position des contacts au-delà de 100µs		
Indice de protection IEC 529 et EN 60529	IP65	IP65	IP66 (actionneurs de types W1, LG : IP65)
Degré de pollution	3		

Compatibilité et conformité

Conforme aux normes	IEC 60947-1, IEC 60947-5-1, EN 60947-1, EN 60947-5-1, UL508 et CSA C22-2 n°14
Résistance climatique	Selon IEC 68-2-3 et brouillard salin selon IEC 68-2-11
Cohérence	0.1mm/0.004" (au point de fermeture) mesuré sur 1 millions de manœuvres
Approbations	   

Raccordement

Brochage

PS21L-A
PS21L-B
PS21L-M
PS21L-N
PS21L-P

PS21L-M1-H/T

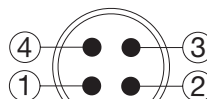

PS21L-M1-M

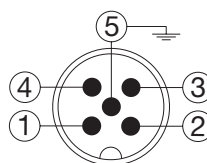

PS21L-D

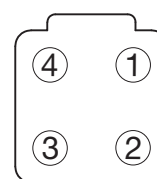

Version de contact	Type de contact	Connexion des bornes	Broche de connecteur M12	Broche de connecteur DT04
S11	Normalement fermé (NF)	21	1	1
		22	2	4
	Normalement ouvert (NO)	13	3	2
		14	4	3
T11	Normalement fermé (NF)	21	1	1
		22	2	4
	Normalement ouvert (NO)	13	3	2
		14	4	3
O11	Normalement fermé (NF)	21	1	1
		22	2	4
	Normalement ouvert (NO)	13	3	2
		14	4	3
S02	Normalement fermé (NF)	21	1	1
		22	2	4
	Normalement fermé (NF)	11	3	2
		12	4	3
T02	Normalement fermé (NF)	21	1	1
		22	2	4
	Normalement fermé (NF)	11	3	2
		12	4	3
T20	Normalement ouvert (NO)	23	1	1
		24	2	4
	Normalement ouvert (NO)	13	3	2
		14	4	3

Boîtier plastique

PS21L - □ □ BE

Dimensions

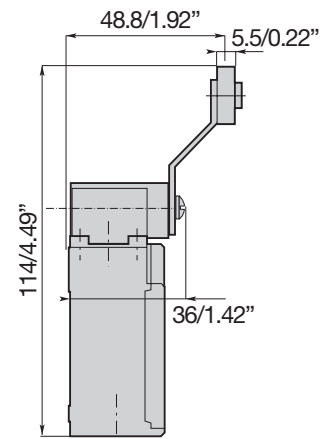
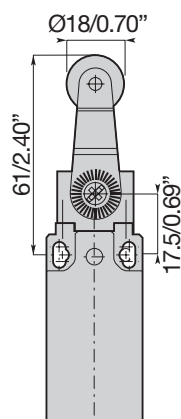

Type de contact

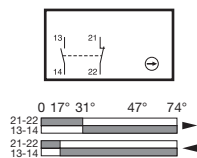

Fig. 9 S11

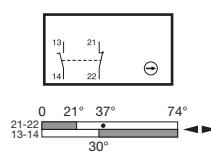

Fig. 10 T11

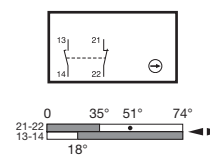

Fig. 11 O11

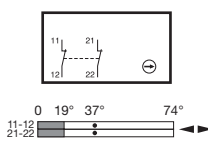

Fig. 12 T02

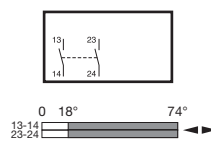

Fig. 13 T20

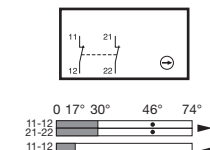

Fig. 14 S02

Caractéristiques

Contact normalement fermé	⊖ Opération d'ouverture forcée selon IEC 60947-5-1
Vitesse max. d'actionnement	1.5m/s / 4.92ft/s
Force ou couple min.	0.10N / 0.32Nm
Poids	95g / 3.351oz
Durabilité mécanique	10 millions de manœuvres
B10d	20 millions de manœuvres

PS21L - □ □ BR

Dimensions

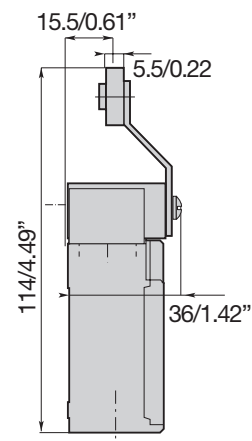
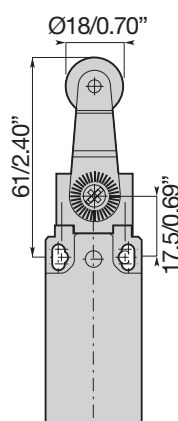
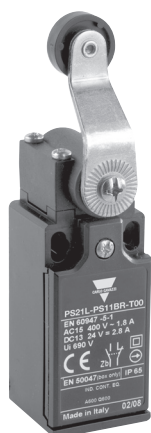

Type de contact

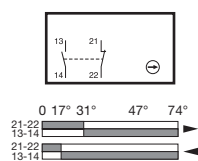

Fig. 15 S11

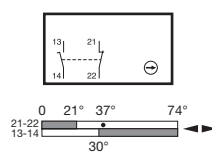

Fig. 16 T11

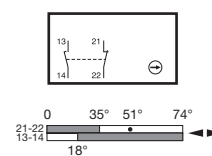

Fig. 17 O11

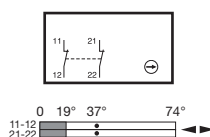

Fig. 18 T02

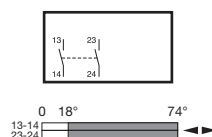

Fig. 19 T20

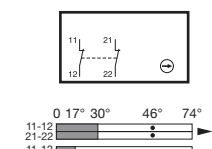

Fig. 20 S02

Caractéristiques

Contact normalement fermé	⊖ Opération d'ouverture forcée selon IEC 60947-5-1
Vitesse max. d'actionnement	1.5m/s / 4.92ft/s
Force ou couple min.	0.10N / 0.32Nm
Poids	95g / 3.351oz
Durabilité mécanique	10 millions de manœuvres
B10d	20 millions de manœuvres

PS21L - □ □ LA

Dimensions

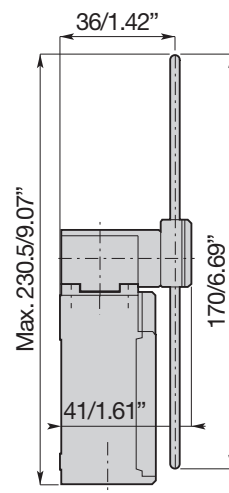
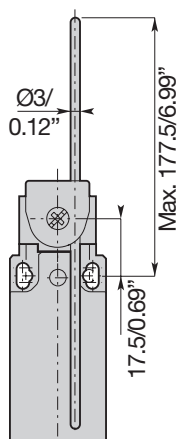

Type de contact

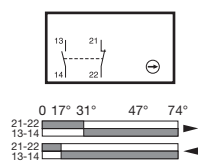

Fig. 21 S11

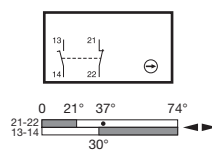

Fig. 22 T11

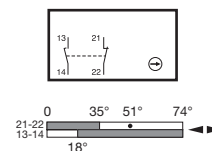

Fig. 23 O11

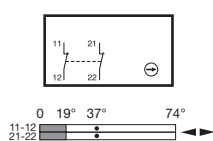

Fig. 24 T02

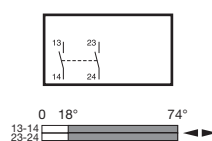

Fig. 25 T20

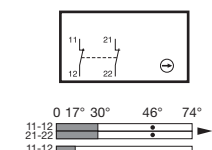

Fig. 26 S02

Caractéristiques

Contact normalement fermé	⊕ opération d'ouverture forcée selon IEC 60947-5-1
Vitesse max. d'actionnement	1.5m/s / 4.92ft/s
Force ou couple min.	0.10N / 0.32Nm
Poids	105g / 3.704oz
Durabilité mécanique	10 millions de manœuvres
B10d	20 millions de manœuvres

PS21L - □ □ LB

Dimensions

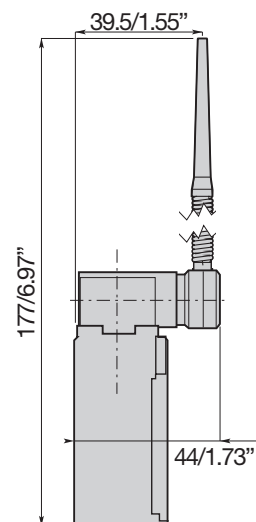
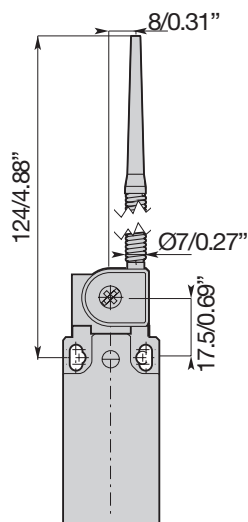
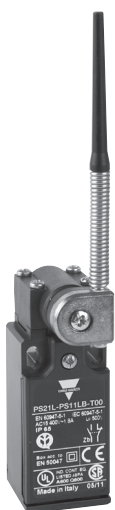

Type de contact

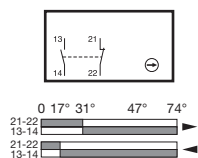

Fig. 27 S11

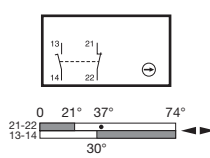

Fig. 28 T11

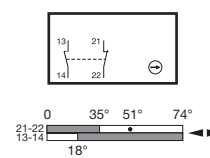

Fig. 29 O11

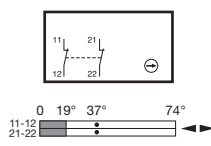

Fig. 30 T02

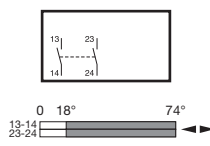

Fig. 31 T20

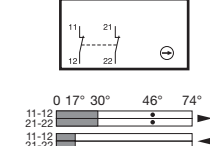

Fig. 32 S02

Caractéristiques

Contact normalement fermé	⊖ opération d'ouverture forcée selon IEC 60947-5-1
Vitesse max. d'actionnement	1.5m/s / 4.92ft/s
Force ou couple min.	0.10N / 0.32Nm
Poids	105g / 3.704oz
Durabilité mécanique	10 millions de manœuvres
B10d	20 millions de manœuvres

PS21L - □ □ LG

Dimensions

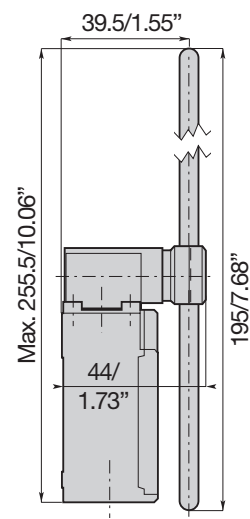
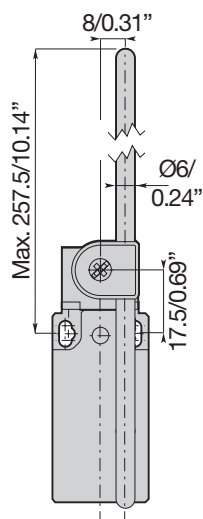

Type de contact

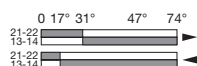
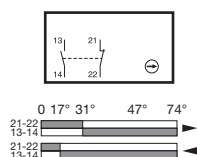

Fig. 33 S11

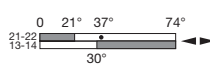
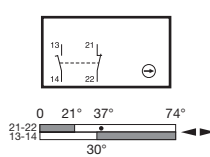

Fig. 34 T11

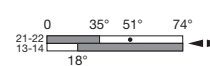
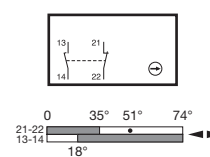

Fig. 35 O11

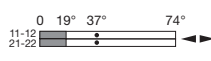
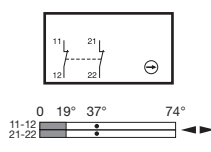

Fig. 36 T02

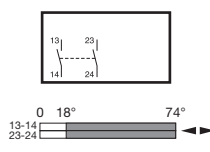

Fig. 37 T20

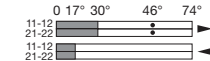
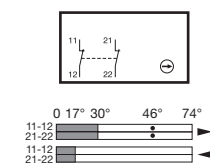

Fig. 38 S02

Caractéristiques

Contact normalement fermé	⊖ opération d'ouverture forcée selon IEC 60947-5-1
Vitesse max. d'actionnement	1.5m/s / 4.92ft/s
Force ou couple min.	0.10N / 0.32Nm
Poids	115g / 4.056oz
Durabilité mécanique	10 millions de manœuvres
B10d	20 millions de manœuvres

PS21L - □ □ LO

Dimensions

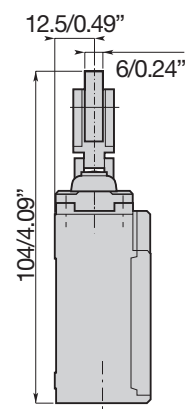
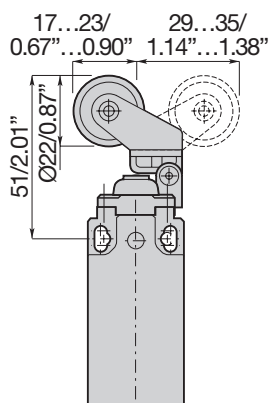

Type de contact

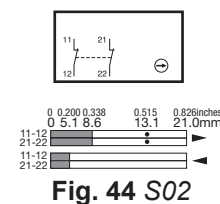
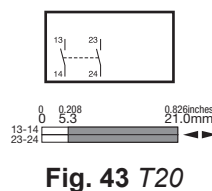
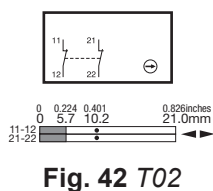
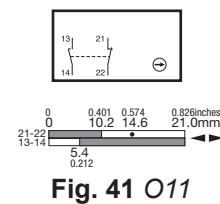
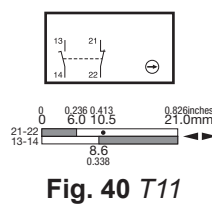
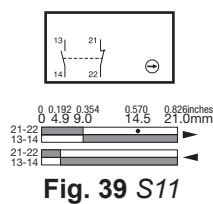

Caractéristiques

Contact normalement fermé	⊖ opération d'ouverture forcée selon IEC 60947-5-1
Vitesse max. d'actionnement	1m/s / 3.28ft/s
Force ou couple min.	7N / 24Nm
Poids	80g / 2.822oz
Durabilité mécanique	5 millions de manœuvres
B10d	10 millions de manœuvres

PS21L - □ □ LP

Dimensions

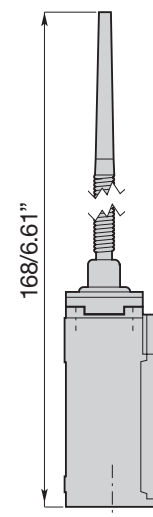
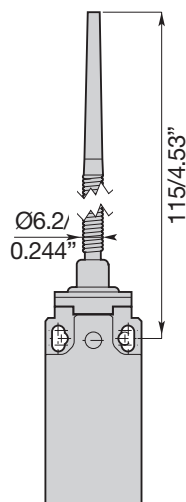

Type de contact

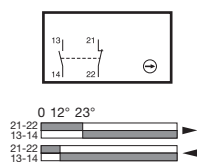

Fig. 45 S11

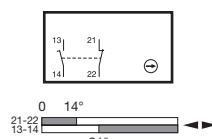

Fig. 46 T11

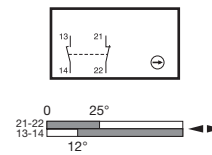

Fig. 47 O11

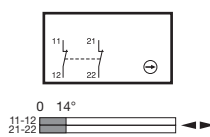

Fig. 48 T02

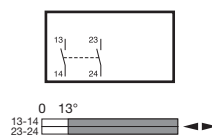

Fig. 49 T20

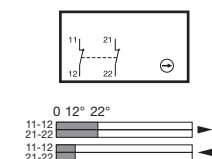

Fig. 50 S02

Caractéristiques

Vitesse max. d'actionnement	1m/s / 3.28ft/s
Force ou couple min.	0.12N
Poids	85g / 2.998oz
Durabilité mécanique	5 millions de manœuvres
B10d	10 millions de manœuvres

PS21L - □ □ LS

Dimensions

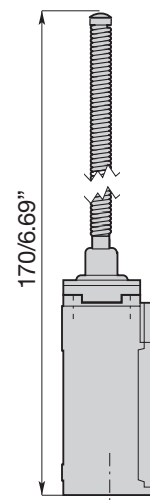
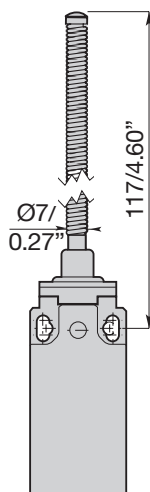

Type de contact

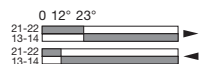
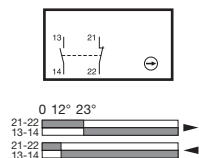

Fig. 51 S11

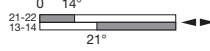
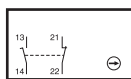

Fig. 52 T11

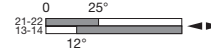
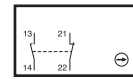

Fig. 53 O11

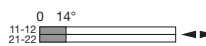
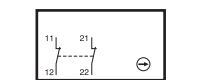

Fig. 54 T02

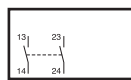

Fig. 55 T20

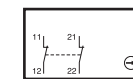

Fig. 56 S02

Caractéristiques

Vitesse max. d'actionnement	1m/s / 3.28ft/s
Force ou couple min.	0.12N
Poids	90g / 3.175oz
Durabilité mécanique	5 millions de manœuvres
B10d	10 millions de manœuvres

PS21L - □ □ LW

Dimensions

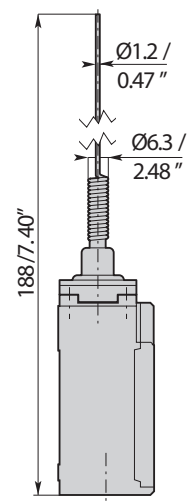
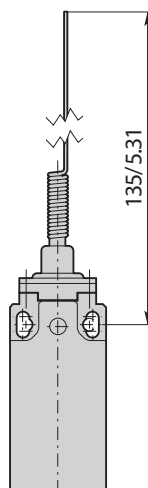

Type de contact

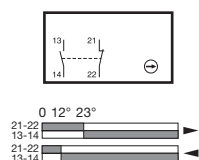

Fig. 57 S11

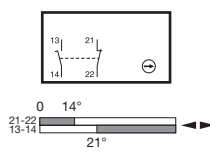

Fig. 58 T11

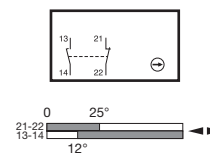

Fig. 59 O11

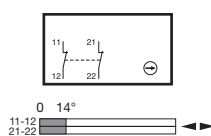

Fig. 60 T02

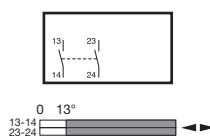

Fig. 61 T20

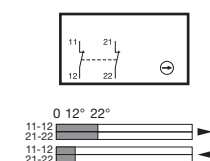

Fig. 62 S02

Caractéristiques

Vitesse max. d'actionnement	1m/s / 3.28ft/s
Force ou couple min.	0.12N
Poids	80g / 2.822oz
Durabilité mécanique	5 millions de manœuvres
B10d	10 millions de manœuvres

PS21L - □ □ N6

► Dimensions

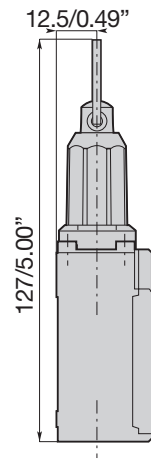
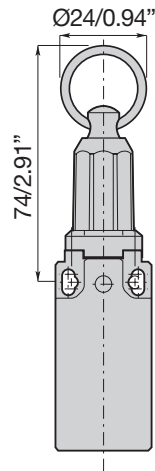
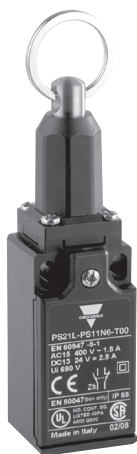

► Type de contact

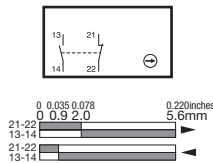

Fig. 63 S11

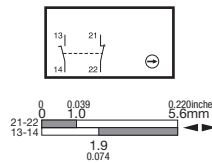

Fig. 64 T11

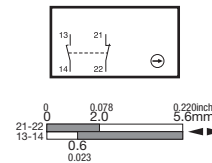

Fig. 65 O11

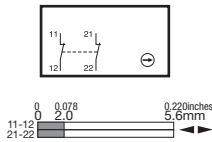

Fig. 66 T02

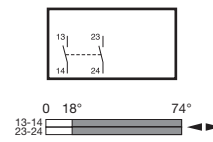

Fig. 67 T20

► Caractéristiques

Vitesse max. d'actionnement	0.5m/s / 1.64ft/s
Force ou couple min.	30N
Poids	115g / 4.056oz
Durabilité mécanique	5 millions de manœuvres
B10d	10 millions de manœuvres

PS21L - □ □ P0

Dimensions

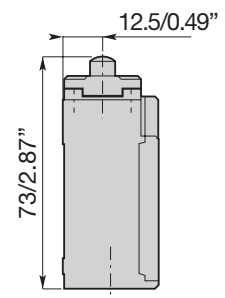
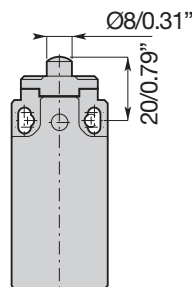

Type de contact

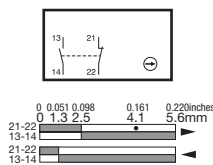

Fig. 68 S11

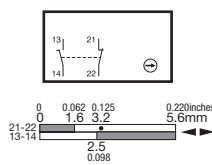

Fig. 69 T11

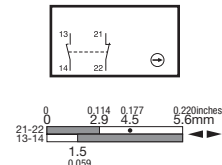

Fig. 70 O11

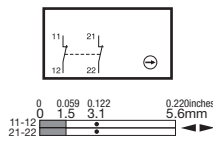

Fig. 71 T02

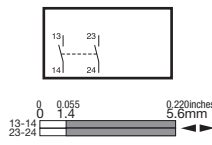

Fig. 72 T20

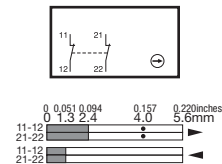

Fig. 73 S02

Caractéristiques

Contact normalement fermé	⊖ opération d'ouverture forcée selon IEC 60947-5-1
Vitesse max. d'actionnement	0.5m/s / 1.64ft/s
Force ou couple min.	15N / 30Nm
Poids	70g / 2.469oz
Durabilité mécanique	15 millions de manœuvres
B10d	30 millions de manœuvres

PS21L - □ □ PH

Dimensions

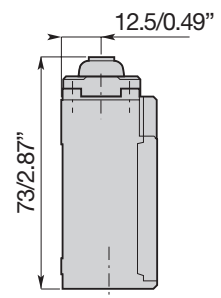
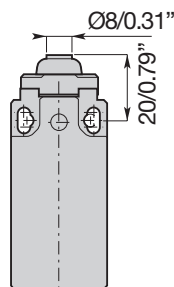

Type de contact

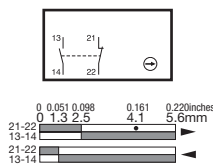

Fig. 74 S11

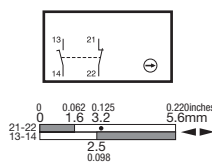

Fig. 75 T11

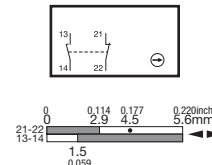

Fig. 76 O11

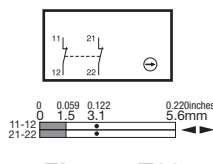

Fig. 77 T02

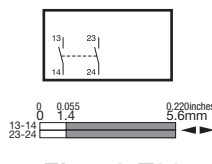

Fig. 78 T20

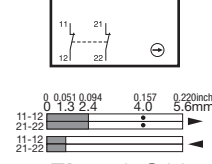

Fig. 79 S02

Caractéristiques

Contact normalement fermé	⊖ opération d'ouverture forcée selon IEC 60947-5-1
Vitesse max. d'actionnement	0.5m/s / 1.64ft/s
Force ou couple min.	15N / 30Nm
Poids	70g / 2.469oz
Durabilité mécanique	5 millions de manœuvres
B10d	10 millions de manœuvres

PS21L - □ □ PR

Dimensions

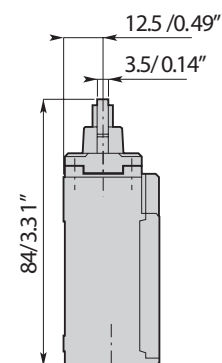
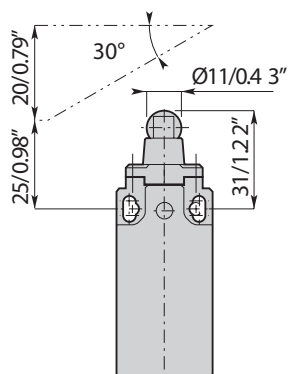

Type de contact

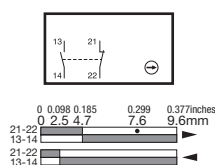

Fig. 80 S11

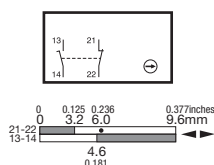

Fig. 81 T11

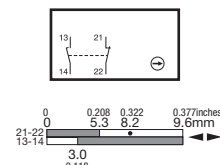

Fig. 82 O11

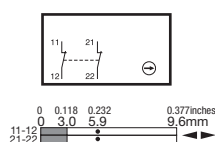

Fig. 83 T02

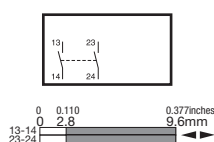

Fig. 84 T20

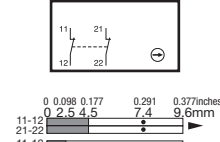

Fig. 85 S02

Caractéristiques

Contact normalement fermé	⊖ opération d'ouverture forcée selon IEC 60947-5-1
Vitesse max. d'actionnement	0.3m/s / 0.98ft/s
Force ou couple min.	12N / 30Nm
Poids	75g / 2.645oz
Durabilité mécanique	15 millions de manœuvres
B10d	30 millions de manœuvres

PS21L - □ □ R1

Dimensions

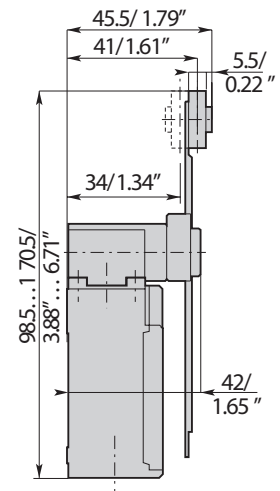
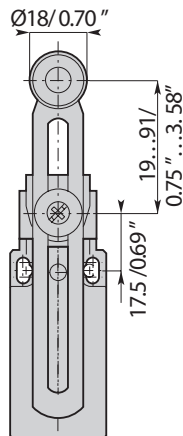
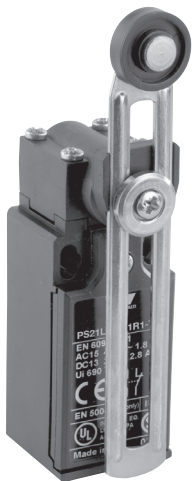

Type de contact

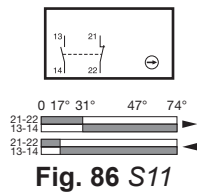

Fig. 86 S11

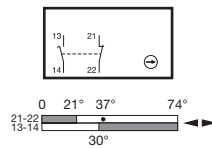

Fig. 87 T11

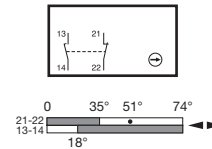

Fig. 88 O11

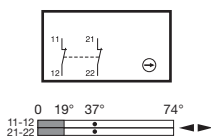

Fig. 89 T02

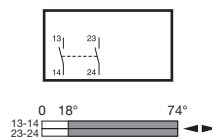

Fig. 90 T20

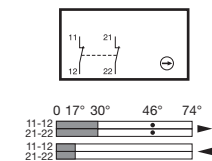

Fig. 91 S02

Caractéristiques

Contact normalement fermé	⊖ opération d'ouverture forcée selon IEC 60947-5-1
Vitesse max. d'actionnement	1.5m/s / 4.92ft/s
Force ou couple min.	0.10N / 0.32Nm
Poids	105g / 3.704oz
Durabilité mécanique	10 millions de manœuvres
B10d	20 millions de manœuvres

PS21L - □ □ RH

Dimensions

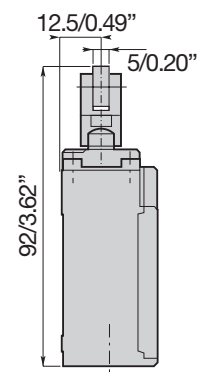
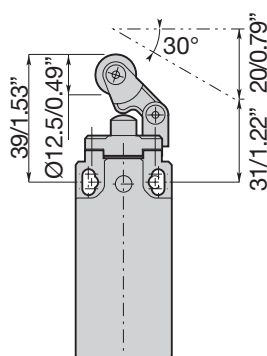

Type de contact

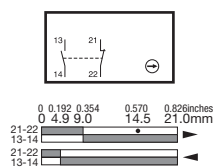

Fig. 92 S11

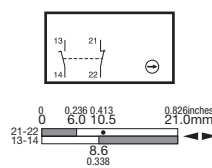

Fig. 93 T11

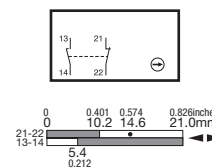

Fig. 94 O11

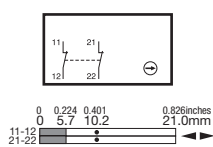

Fig. 95 T02

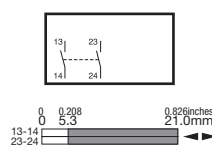

Fig. 96 T20

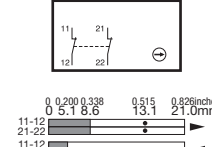

Fig. 97 S02

Caractéristiques

Contact normalement fermé	⊕ opération d'ouverture forcée selon IEC 60947-5-1
Vitesse max. d'actionnement	1m/s / 3.28ft/s
Force ou couple min.	7N / 24Nm
Poids	75g / 2.645oz
Durabilité mécanique	15 millions de manœuvres
B10d	30 millions de manœuvres

PS21L - □ □ RT

Dimensions

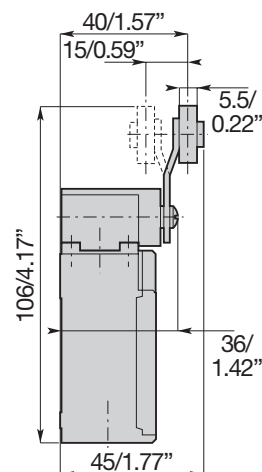
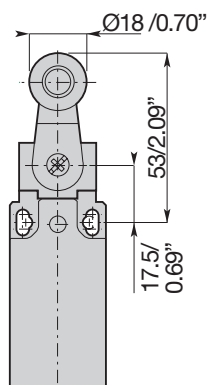

Type de contact

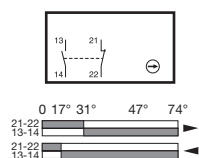

Fig. 98 S11

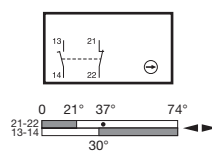

Fig. 99 T11

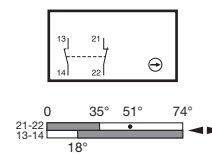

Fig. 100 O11

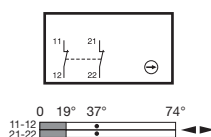

Fig. 101 T02

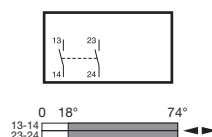

Fig. 102 T20

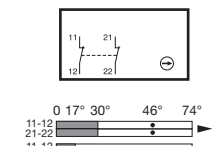

Fig. 103 S02

Caractéristiques

Contact normalement fermé	⊖ opération d'ouverture forcée selon IEC 60947-5-1
Vitesse max. d'actionnement	1.5m/s / 4.92ft/s
Force ou couple min.	0.10N / 0.32Nm
Poids	95g / 3.351oz
Durabilité mécanique	10 millions de manœuvres
B10d	20 millions de manœuvres

PS21L - □ □ RV

Dimensions

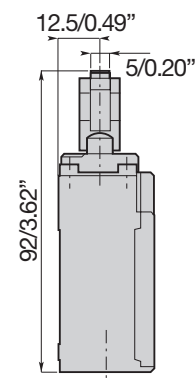
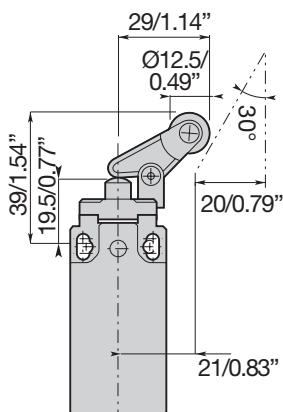

Type de contact

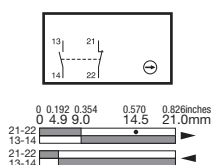

Fig. 104 S11

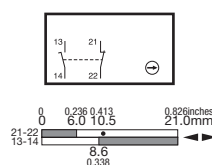

Fig. 105 T11

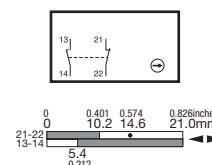

Fig. 106 O11

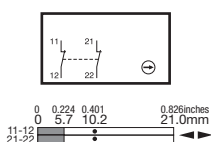

Fig. 107 T02

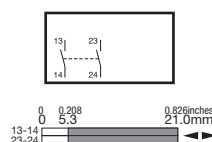

Fig. 108 T20

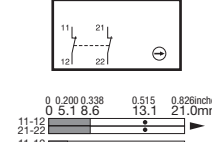

Fig. 109 S02

Caractéristiques

Contact normalement fermé	⊖ opération d'ouverture forcée selon IEC 60947-5-1
Vitesse max. d'actionnement	1m/s / 3.28ft/s
Force ou couple min.	7N / 24Nm
Poids	80g / 2.822oz
Durabilité mécanique	15 millions de manœuvres
B10d	30 millions de manœuvres

PS21L - □ □ W0

► Dimensions

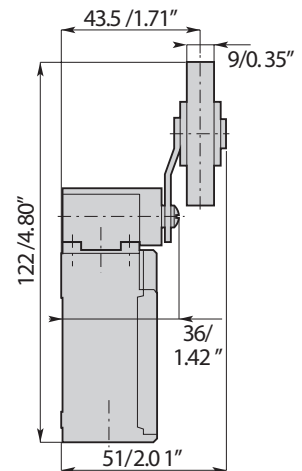
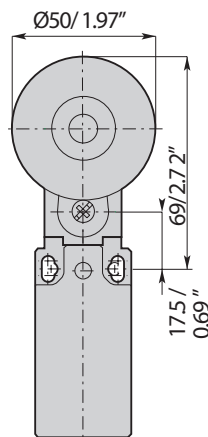
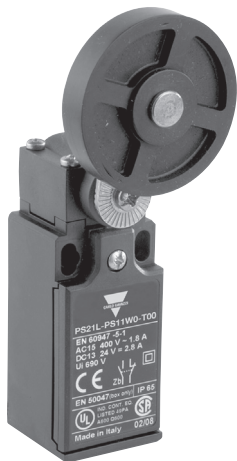

► Type de contact

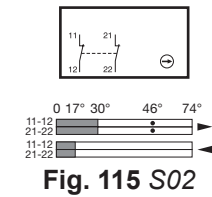
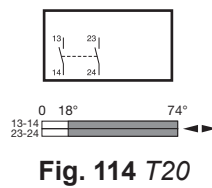
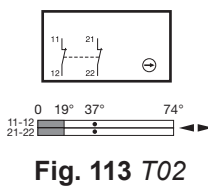
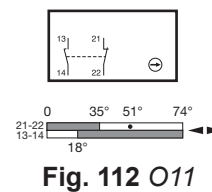
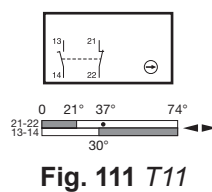
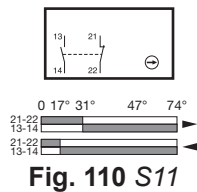

► Caractéristiques

Contact normalement fermé	⊕ opération d'ouverture forcée selon IEC 60947-5-1
Vitesse max. d'actionnement	1.5m/s / 4.92ft/s
Force ou couple min.	0.10N / 0.32Nm
Poids	115g / 4.056oz
Durabilité mécanique	10 millions de manœuvres
B10d	20 millions de manœuvres

PS21L - □ □ W1

Dimensions

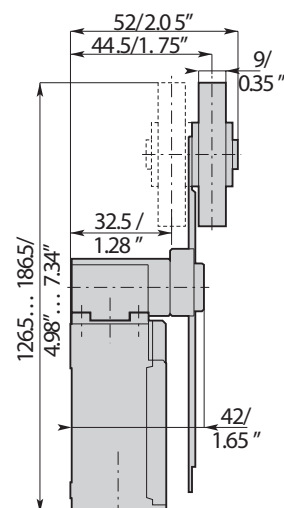
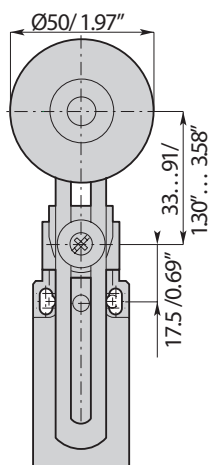
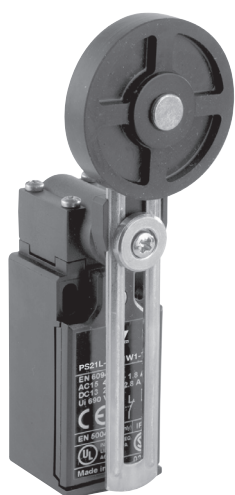

Type de contact

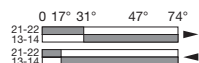
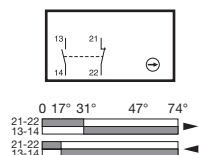

Fig. 116 S11

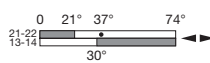
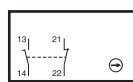

Fig. 117 T11

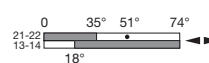
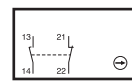

Fig. 118 O11

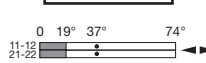
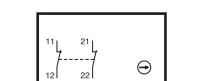

Fig. 119 T02

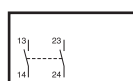

Fig. 120 T20

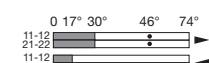
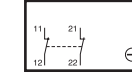

Fig. 121 S02

Caractéristiques

Contact normalement fermé	⊖ opération d'ouverture forcée selon IEC 60947-5-1
Vitesse max. d'actionnement	1.5m/s / 4.92ft/s
Force ou couple min.	0.10N / 0.32Nm
Poids	125g / 4.409oz
Durabilité mécanique	10 millions de manœuvres
B10d	20 millions de manœuvres

Boîtier métallique

PS21L - BE

Dimensions

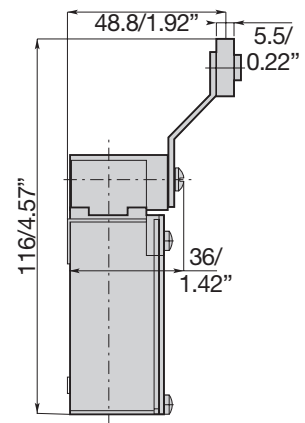
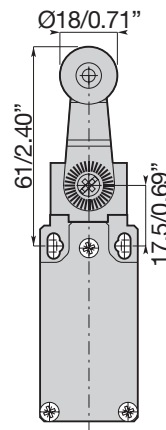

Type de contact

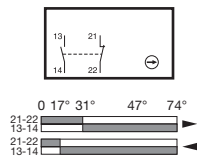

Fig. 122 S11

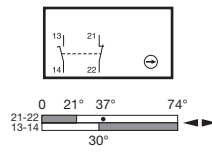

Fig. 123 T11

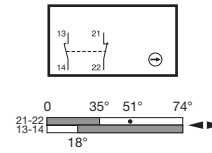

Fig. 124 O11

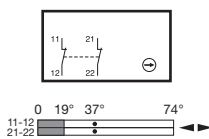

Fig. 125 T02

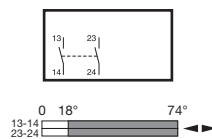

Fig. 126 T20

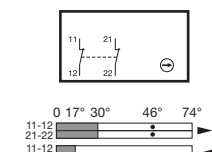

Fig. 127 S02

Caractéristiques

Contact normalement fermé	⊖ opération d'ouverture forcée selon IEC 60947-5-1
Vitesse max. d'actionnement	1.5m/s / 4.92ft/s
Force ou couple min.	0.10N / 0.32Nm
Poids	250g / 8.818oz
Durabilité mécanique	10 millions de manœuvres
B10d	20 millions de manœuvres

PS21L - BM

Dimensions

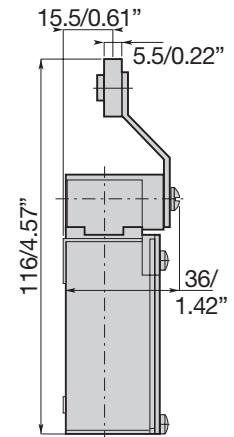
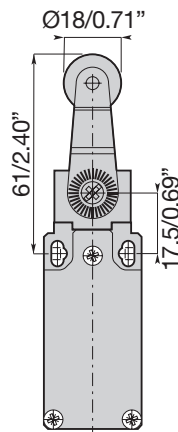

Type de contact

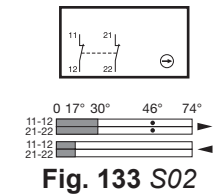
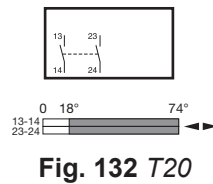
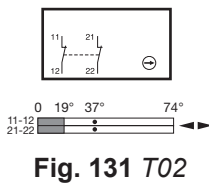
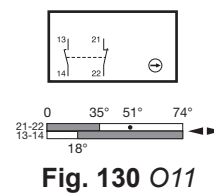
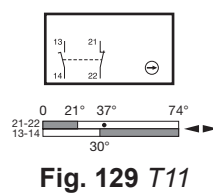
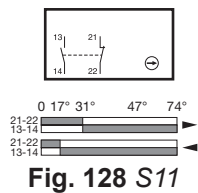

Caractéristiques

Contact normalement fermé	⊖ opération d'ouverture forcée selon IEC 60947-5-1
Vitesse max. d'actionnement	1.5m/s / 4.92ft/s
Force ou couple min.	0.10N / 0.32Nm
Poids	250g / 8.818oz
Durabilité mécanique	10 millions de manœuvres
B10d	20 millions de manœuvres

PS21L - □ □ BR

Dimensions

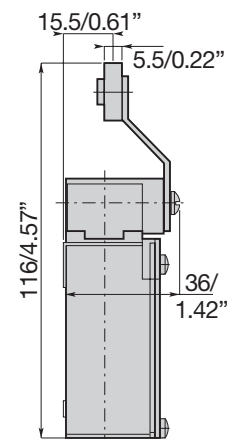
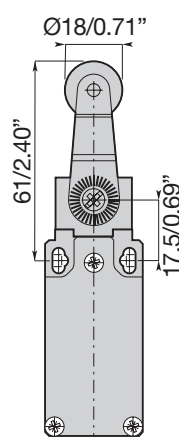

Type de contact

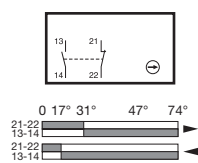

Fig. 134 S11

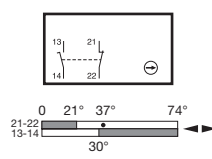

Fig. 135 T11

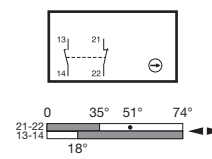

Fig. 136 O11

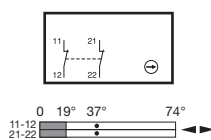

Fig. 137 T02

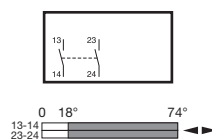

Fig. 138 T20

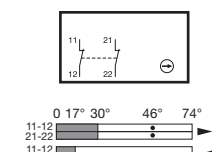

Fig. 139 S02

Caractéristiques

Contact normalement fermé	⊖ opération d'ouverture forcée selon IEC 60947-5-1
Vitesse max. d'actionnement	1.5m/s / 4.92ft/s
Force ou couple min.	0.10N / 0.32Nm
Poids	250g / 8.818oz
Durabilité mécanique	10 millions de manœuvres
B10d	20 millions de manœuvres

PS21L - □ □ LA

Dimensions

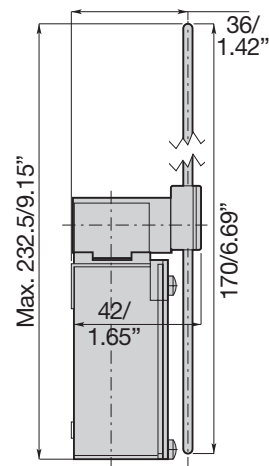
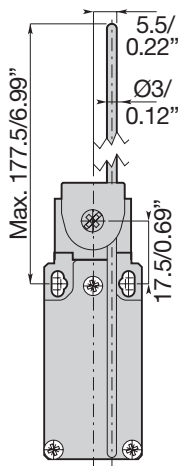

Type de contact

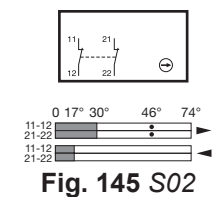
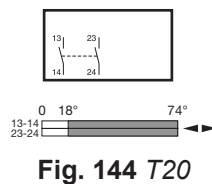
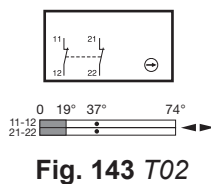
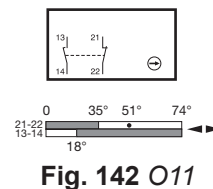
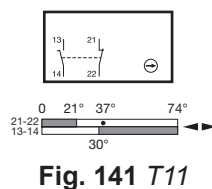
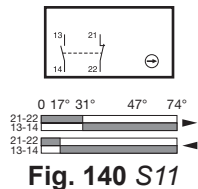

Caractéristiques

Contact normalement fermé	⊕ opération d'ouverture forcée selon IEC 60947-5-1
Vitesse max. d'actionnement	1.5m/s / 4.92ft/s
Force ou couple min.	0.10N / 0.32Nm
Poids	245g / 8.642oz
Durabilité mécanique	10 millions de manœuvres
B10d	20 millions de manœuvres

PS21L - □ □ LB

Dimensions

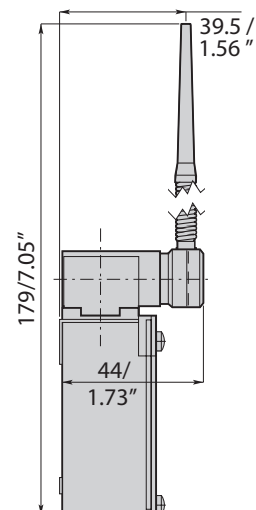
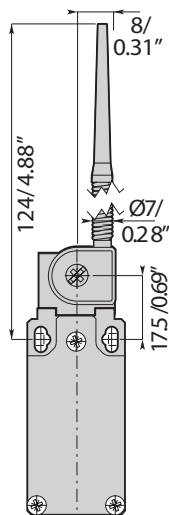
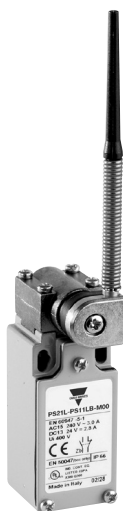

Type de contact

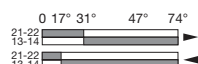
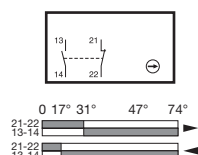

Fig. 146 S11

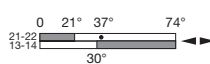
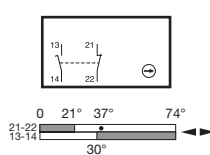

Fig. 147 T11

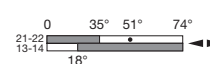
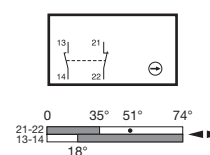

Fig. 148 O11

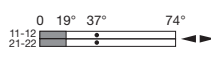
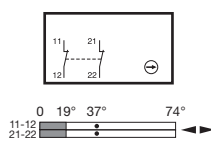

Fig. 149 T02

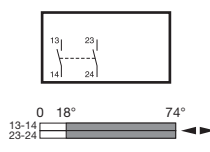

Fig. 150 T20

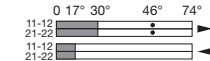
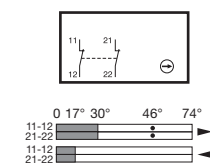

Fig. 151 S02

Caractéristiques

Contact normalement fermé	⊖ opération d'ouverture forcée selon IEC 60947-5-1
Vitesse max. d'actionnement	1.5m/s / 4.92ft/s
Force ou couple min.	0.10N / 0.32Nm
Poids	245g / 8.642oz
Durabilité mécanique	10 millions de manœuvres
B10d	20 millions de manœuvres

PS21L - □ □ LG

► Dimensions

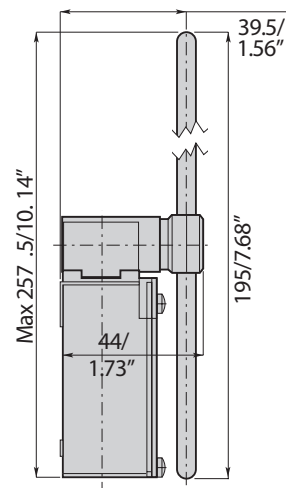
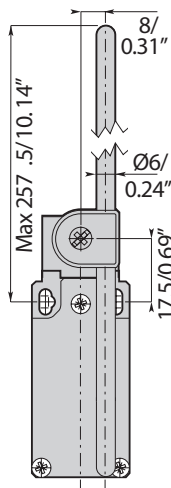

► Type de contact

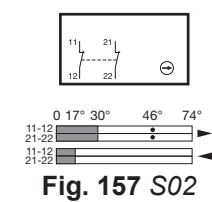
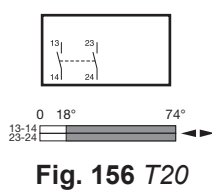
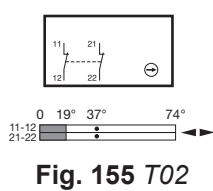
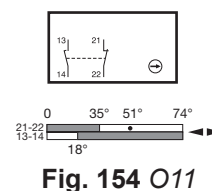
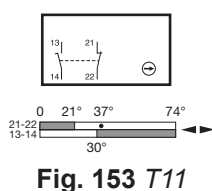
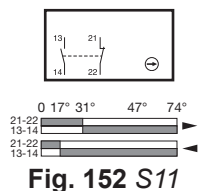

► Caractéristiques

Contact normalement fermé	⊕ opération d'ouverture forcée selon IEC 60947-5-1
Vitesse max. d'actionnement	1.5m/s / 4.92ft/s
Force ou couple min.	0.10N / 0.32Nm
Poids	255g / 8.995oz
Durabilité mécanique	10 millions de manœuvres
B10d	20 millions de manœuvres

PS21L - □ □ P0

Dimensions

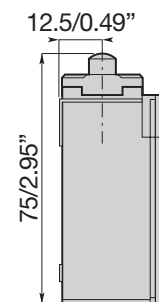
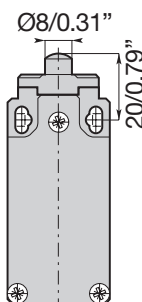

Type de contact

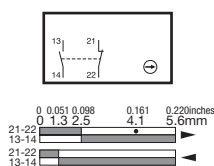

Fig. 158 S11

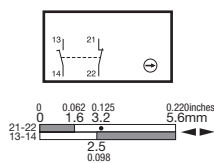

Fig. 159 T11

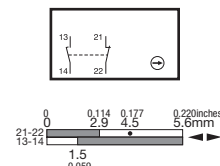

Fig. 160 O11

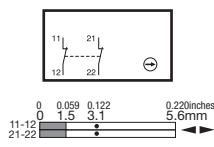

Fig. 161 T02

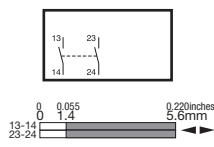

Fig. 162 T20

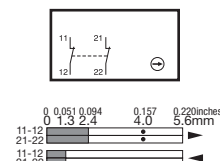

Fig. 163 S02

Caractéristiques

Contact normalement fermé	⊖ opération d'ouverture forcée selon IEC 60947-5-1
Vitesse max. d'actionnement	0.5m/s / 1.64ft/s
Force ou couple min.	15N / 30Nm
Poids	180g / 6.349oz
Durabilité mécanique	15 millions de manœuvres
B10d	30 millions de manœuvres

PS21L - □ □ PR

Dimensions

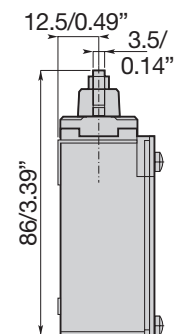
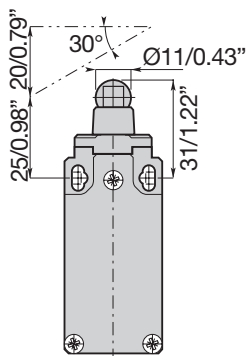

Type de contact

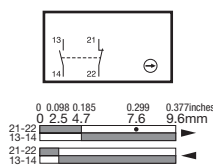

Fig. 164 S11

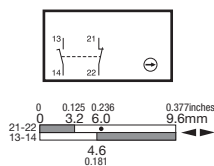

Fig. 165 T11

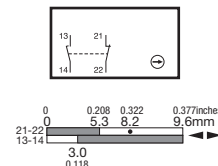

Fig. 166 O11

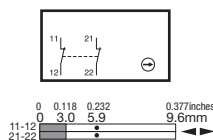

Fig. 167 T02

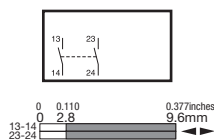

Fig. 168 T20

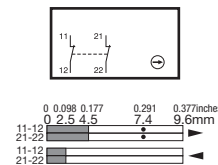

Fig. 169 S02

Caractéristiques

Contact normalement fermé	⊖ opération d'ouverture forcée selon IEC 60947-5-1
Vitesse max. d'actionnement	0.3m/s / 0.98ft/s
Force ou couple min.	12N / 30Nm
Poids	190g / 6.702oz
Durabilité mécanique	15 millions de manœuvres
B10d	30 millions de manœuvres

PS21L - □ □ R1

Dimensions

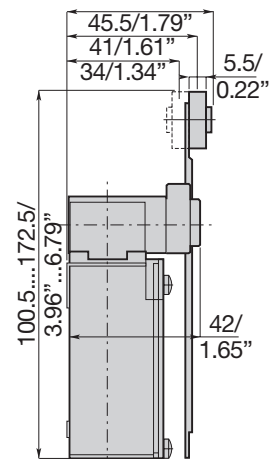
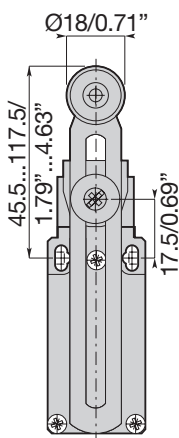
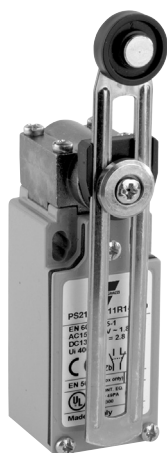

Type de contact

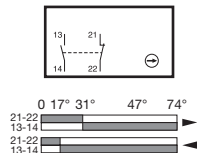

Fig. 170 S11

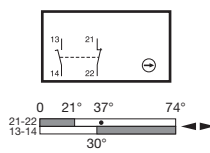

Fig. 171 T11

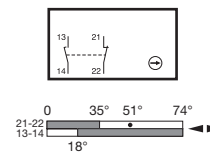

Fig. 172 O11

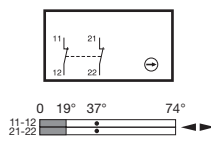

Fig. 173 T02

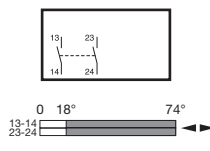

Fig. 174 T20

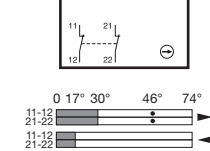

Fig. 175 S02

Caractéristiques

Contact normalement fermé	⊖ opération d'ouverture forcée selon IEC 60947-5-1
Vitesse max. d'actionnement	1.5m/s / 4.92ft/s
Force ou couple min.	0.10N / 0.32Nm
Poids	245g / 8.642oz
Durabilité mécanique	10 millions de manœuvres
B10d	20 millions de manœuvres

PS21L - □ □ RT

Dimensions

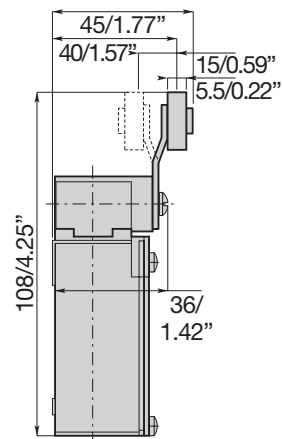
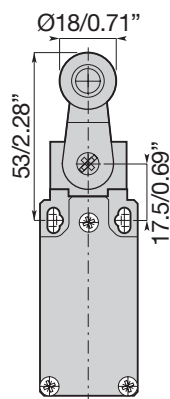

Type de contact

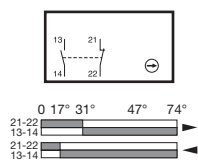

Fig. 176 S11

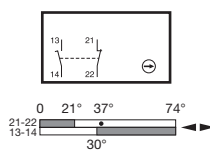

Fig. 177 T11

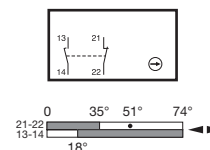

Fig. 178 O11

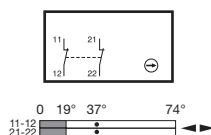

Fig. 179 T02

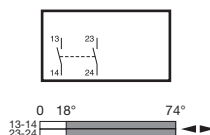

Fig. 180 T20

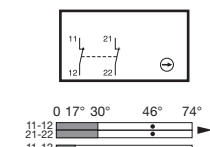

Fig. 181 S02

Caractéristiques

Contact normalement fermé	⊕ opération d'ouverture forcée selon IEC 60947-5-1
Vitesse max. d'actionnement	1.5m/s / 4.92ft/s
Force ou couple min.	0.10N / 0.32Nm
Poids	235g / 8.289oz
Durabilité mécanique	10 millions de manœuvres
B10d	20 millions de manœuvres

PS21L - □ □ W0

► Dimensions

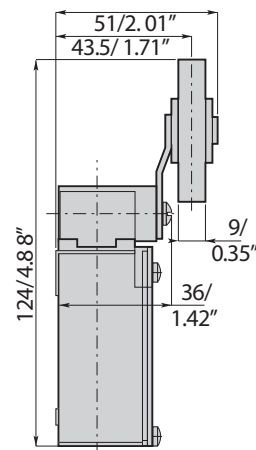
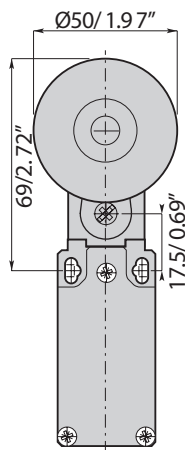

► Type de contact

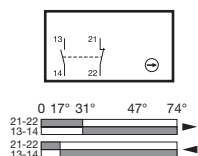

Fig. 182 S11

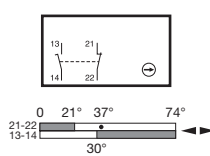

Fig. 183 T11

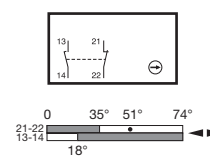

Fig. 184 O11

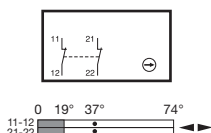

Fig. 185 T02

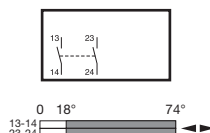

Fig. 186 T20

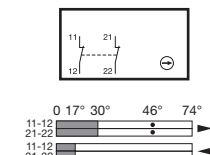

Fig. 187 S02

► Caractéristiques

Contact normalement fermé	⊖ opération d'ouverture forcée selon IEC 60947-5-1
Vitesse max. d'actionnement	1.5m/s / 4.92ft/s
Force ou couple min.	0.10N / 0.32Nm
Poids	255g / 8.995oz
Durabilité mécanique	10 millions de manœuvres
B10d	20 millions de manœuvres

PS21L - □ □ W1

Dimensions

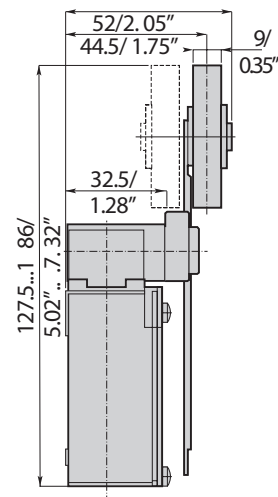
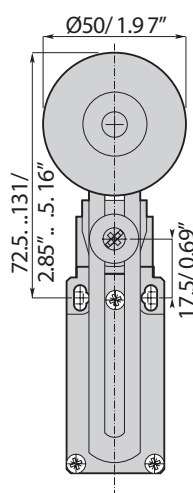
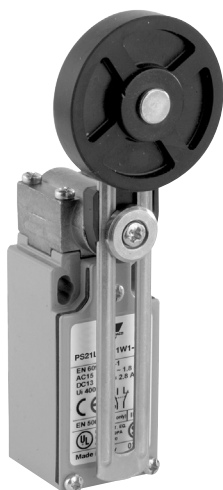

Type de contact

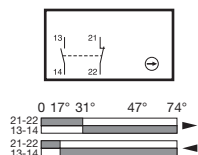

Fig. 188 S11

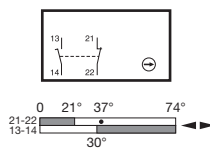

Fig. 189 T11

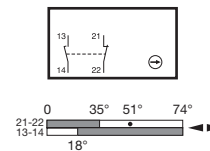

Fig. 190 O11

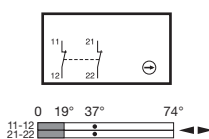

Fig. 191 T02

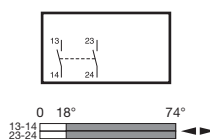

Fig. 192 T20

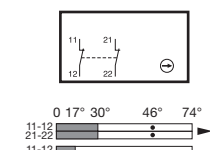

Fig. 193 S02

Caractéristiques

Contact normalement fermé	⊕ opération d'ouverture forcée selon IEC 60947-5-1
Vitesse max. d'actionnement	1.5m/s / 4.92ft/s
Force ou couple min.	0.10N / 0.32Nm
Poids	265g / 9.348oz
Durabilité mécanique	10 millions de manœuvres
B10d	20 millions de manœuvres



COPYRIGHT ©2021

Sous réserve de modifications. Télécharger le PDF: www.gavazziautomation.com