

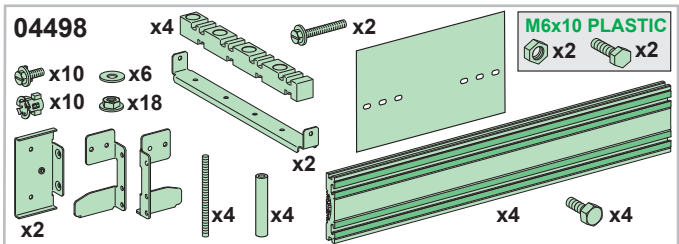

en fr es de it pt zh ru

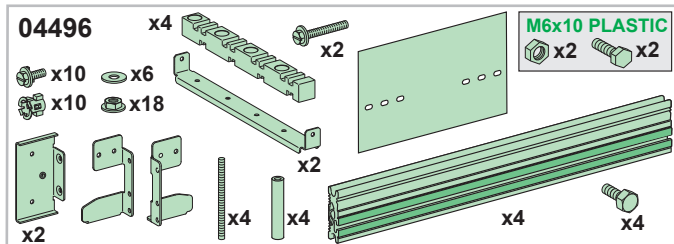
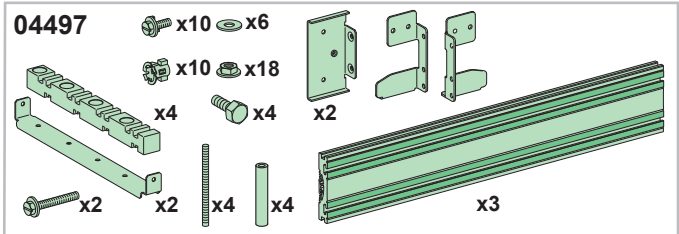
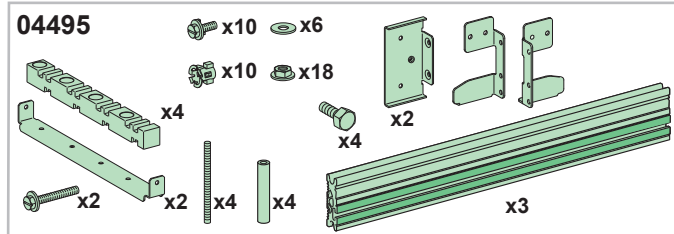
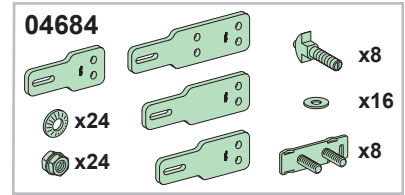
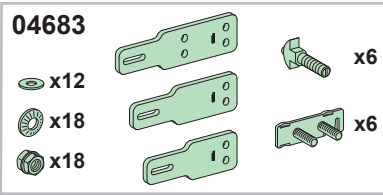
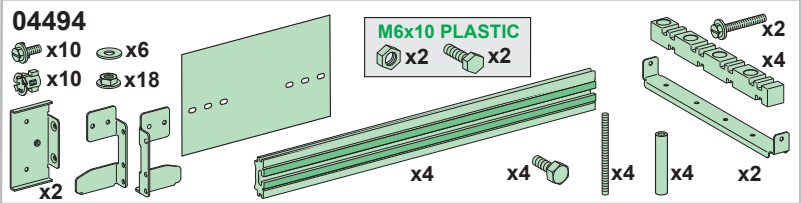
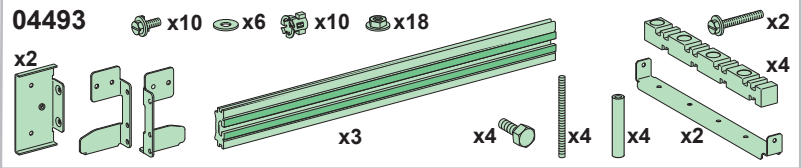
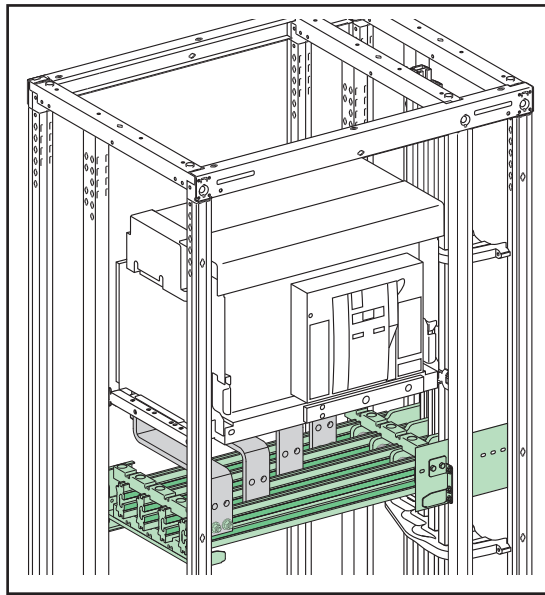

PLEASE NOTE
Electrical equipment should be installed, operated, serviced, and maintained only by qualified personnel. No responsibility is assumed by Schneider Electric for any consequences arising out of the use of this material.

REMARQUE IMPORTANTE
L'installation, l'utilisation, la réparation et la maintenance des équipements électriques doivent être assurées uniquement par du personnel qualifié. Schneider Electric décline toute responsabilité quant aux conséquences de l'utilisation de ce matériel.

TENGA EN CUENTA
La instalación, manejo, puesta en servicio y mantenimiento de equipos eléctricos deberán ser realizados sólo por personal cualificado. Schneider Electric no se hace responsable de ninguna de las consecuencias del uso de este material.

BITTE BEACHTEN
Elektrische Geräte dürfen nur von Fachpersonal installiert, betrieben, bedient und gewartet werden. Schneider Electric haftet nicht für Schäden, die durch die Verwendung dieses Materials entstehen.

NOTA
Manutenzione, riparazione, installazione e uso delle apparecchiature elettriche si devono affidare solo a personale qualificato. Schneider Electric non si assume alcuna responsabilità per qualsiasi conseguenza derivante dall'uso di questo materiale.

NOTA
A instalação, utilização e manutenção do equipamento eléctrico devem ser efectuadas exclusivamente por pessoal qualificado. A Schneider Electric não assume qualquer responsabilidade pelas consequências resultantes da utilização deste material.

请注意
电气设备的安装、操作、维修和维护工作仅限于合格人员执行。Schneider Electric不承担由于使用本资料所引起的任何后果。

ОБРАТИТЕ ВНИМАНИЕ
Установка, эксплуатация, ремонт и обслуживание электрического оборудования может выполняться только квалифицированными электриками. Компания Schneider Electric не несет никакой ответственности за любые возможные последствия использования данной документации.

**DANGER / DANGER / PELIGRO / PERIGO / PERICOLO / GEFAHR / 危险 / ОПАСНО**

<p>HAZARD OF ELECTRIC SHOCK, EXPLOSION, OR ARC FLASH You must fit the Linergy LGYE busbar according to the recommendations given in this document. Failure to follow these instructions will result in death or serious injury.</p>	<p>RISQUE D'ÉLECTROCUTION, D'EXPLOSION OU D'ARC ELECTRIQUE Vous devez impérativement monter le jeu de barres Linergy LGYE, en respectant les préconisations indiquées dans ce document. Le non-respect de ces instructions provoquera la mort ou des blessures graves.</p>	<p>PELIGRO DE DESCARGA ELÉCTRICA, EXPLOSIÓN O ARCO ELÉCTRICO Se deben montar las barras Linergy LGYE según las recomendaciones especificadas en este documento. Si no se siguen estas instrucciones provocará lesiones graves o incluso la muerte.</p>	<p>RISCO DE ELECTROCUSSÃO, DE EXPLOSIÃO, OU DE ARCO ELÉCTRICO Deve instalar a barra de suporte Linergy LGYE de acordo com as recomendações indicadas neste documento. A não observância destas instruções resultará em morte, ou ferimentos graves.</p>
<p>RISCHIO DI SCARICA ELETTRICA , ESPLOSIONE O ARCO ELETTRICO Installare la barra collettore Linergy LGYE conformemente alle raccomandazioni fornite nel presente documento. I mancato rispetto di queste istruzioni provocherà morte o gravi infortuni.</p>	<p>GEFAHR VON ELEKTRISCHEM SCHLAG, EXPLOSION ODER LICHTBOGEN Bringen Sie die Linergy-LGYE-Sammelschiene gemäß den Empfehlungen in diesem Dokument an. Die Nichtbeachtung dieser Anweisungen führt zu Tod oder schwerer Körperverletzung.</p>	<p>可能有触电、爆炸或者电弧灼伤的危險 您必須按照此文档中给出的建议安装 Linergy LGYE 母线。 则可能会导致严重的人身伤害甚至死亡。</p>	<p>Опасность поражением электрическим током, опасность взрыва или вспышки дуги. Необходимо установить сборную шину Linergy LGYE в соответствии с рекомендациями, приведенными в настоящем документе. Несоблюдение этих инструкций приведет к смерти или серьезной травме.</p>
<p>PLEASE NOTE To fit the Linergy LGYE bar in 4P with the links opposite an upright, you must use the isolating screen neutral kit delivered with the 4-pole references.</p>	<p>REMARQUE IMPORTANTE Pour le montage des barres Linergy LGYE en 4P, avec les liaisons en face d'un montant, il faut utiliser le kit écran éclipse-neutre livré avec les références 4 pôles.</p>	<p>TENGA EN CUENTA Para montar las barras Linergy LGYE en 4P con las uniones opuestas a una conexión vertical, se debe utilizar el kit de aislamiento de pantallas de neutro entregado con las referencias de 4 polos.</p>	<p>NOTA Para instalar a barra Linergy LGYE em 4 pólos, com as ligações opostas na vertical, deve utilizar o kit neutro do ecrã de isolamento fornecido com as referências de 4 pólos.</p>
<p>NOTA IMPORTANTE Per adattare la barra Linergy LGYE quadripolare ai collegamenti contrapposti al montante, è necessario utilizzare il kit di isolamento del neutro che viene fornito insieme ai riferimenti quadripolari.</p>	<p>BITTE BEACHTEN Für die Anbringung der Linergy-LGYE-Schiene in 4P-Ausführung, deren Verbindungen sich gegenüber einer aufrecht stehenden Stütze befinden, müssen Sie den Isolierschirm für den Neutralleiter verwenden, der im Lieferumfang der 4-poligen Modelle enthalten ist.</p>	<p>请注意 若要连接 4 极中的 Linergy LGYE 母线与立柱对面的链路，您必须使用与四极参照物一同交付的绝缘屏幕中线套件。</p>	<p>ВАЖНО Для установки сборной шины Linergy LGYE в 4P с противоположным вертикальным расположением соединений необходимо использовать комплект изолирующего экрана для нейтрали с 4-полюсными метками.</p>
<p>Prisma switchboards equipped with the Linergy busbar connection system and Schneider Electric switchgear are subject to IEC 61439-1 & 2 certification. The instructions in this document describe how to fit Linergy in a Prisma switchboard. The installer is fully liable if it is fitted in any other switchboard.</p>	<p>Les tableaux Prisma équipés du système de répartition, de connexion Linergy et d'appareillages Schneider Electric font l'objet d'une certification CEI61439-1 & 2. Les instructions de ce document décrivent le montage de Linergy dans un tableau Prisma. Le montage dans tout autre tableau est de la responsabilité du metteur en œuvre.</p>	<p>Los paneles Prisma equipados con el sistema de distribución y conexión Linergy y con equipos Schneider Electric cuentan con la certificación IEC61439-1 & 2. Las instrucciones de este documento describen el montaje de Linergy en el interior de un panel Prisma. El montaje de dicho sistema en cualquier otro panel será responsabilidad del instalador.</p>	<p>Die Prisma-Schaltanlage mit Verteilungssystem sowie Anschluss für Linergy-Systeme und Geräte von Schneider Electric sind gemäß IEC61439-1 & 2 zertifiziert. Die Anweisungen in diesem Dokument beschreiben die Montage des Linergy-Systems in einer Prisma-Schaltanlage. Die Montage in einer anderen Schaltanlage obliegt dem Nutzer.</p>
<p>I quadri Prisma dotati di sistema di ripartizione e connessione Linergy e di apparecchiature Schneider Electric sono certificati secondo la norma IEC 61439-1 e 2. Le presenti istruzioni descrivono il montaggio di Linergy in un quadro Prisma. Il montaggio in qualsiasi altro quadro ricade sotto la responsabilità dell'installatore.</p>	<p>Os quadros Prisma equipados com o sistema de repartição e ligação Linergy e as aparelhagens Schneider Electric são objecto de uma certificação IEC61439-1 & 2. A instruções deste documento descrevem a montagem de Linergy num quadro Prisma. A montagem em qualquer outro quadro é da responsabilidade do instalador.</p>	<p>配有 Linergy 母线连接系统和 Schneider Electric 开关设备的 Prisma 配电盘通过 IEC 61439-1 & 2 认证。 本文阐释如何在 Prisma 配电盘中安装 Linergy。 如果安装在任何其他配电盘中，该安装程序也同样适用。</p>	<p>Распределительные щиты Prisma, снабженные системой соединения сборной шины Linergy и распределительного устройства Schneider Electric, подпадают под сертификацию IEC 61439-1 и 2. Инструкции в данном документе объясняют как установить Linergy в распределительный щит Prisma. Ответственность за установку в любой иной распределительный щит полностью лежит на монтажнике.</p>

A

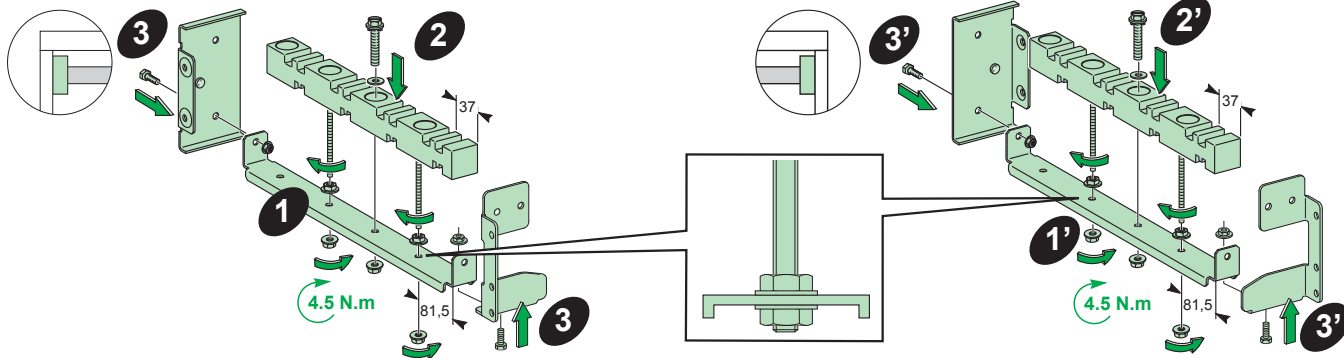
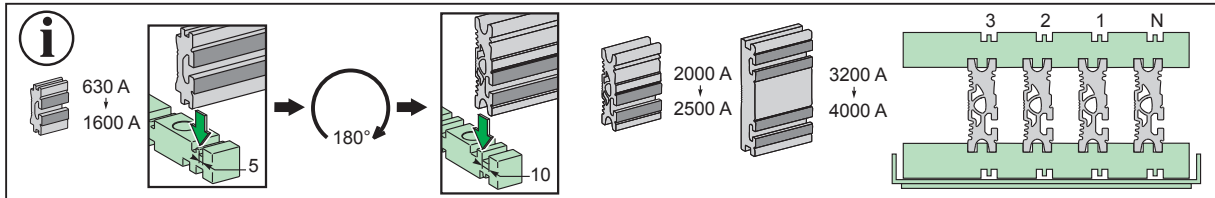

B

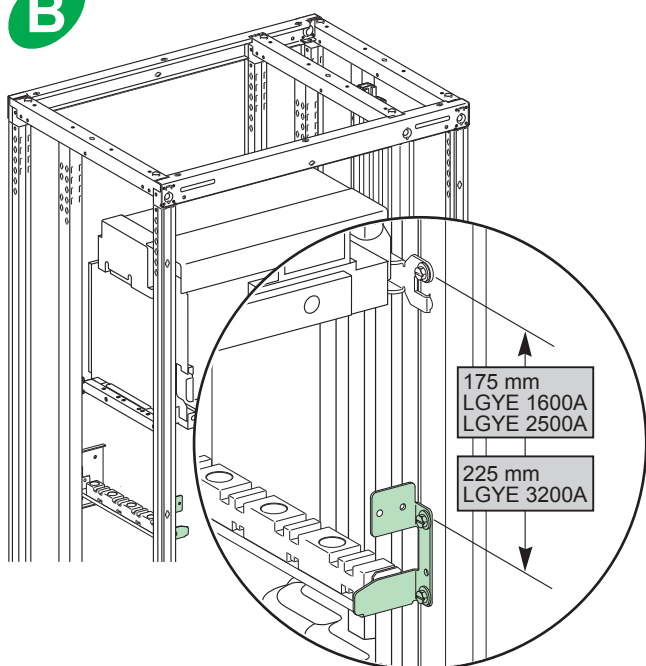

C

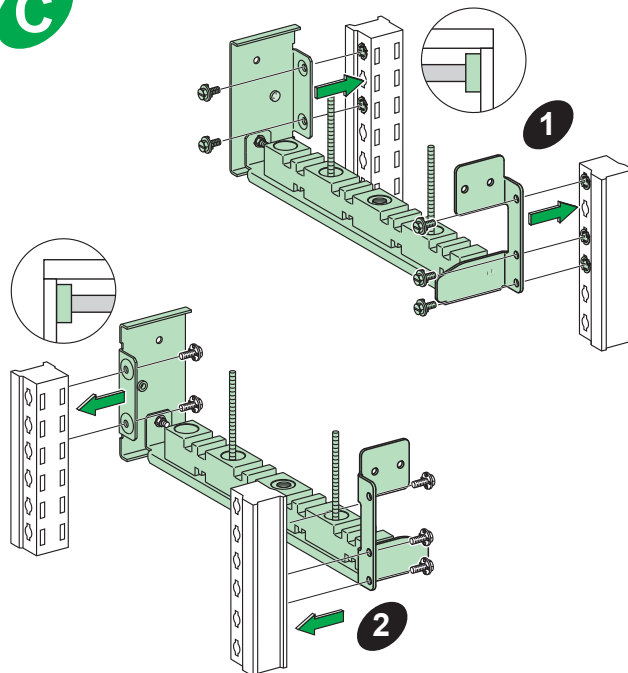

i

1600 A / 2500 A / 3200 A

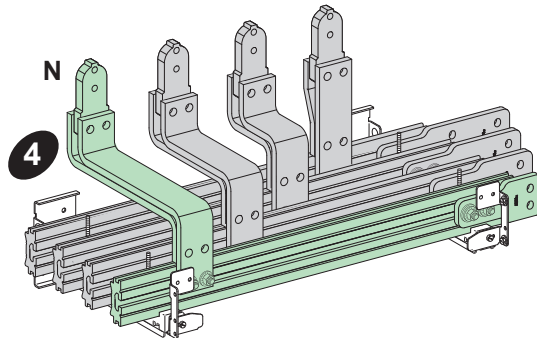
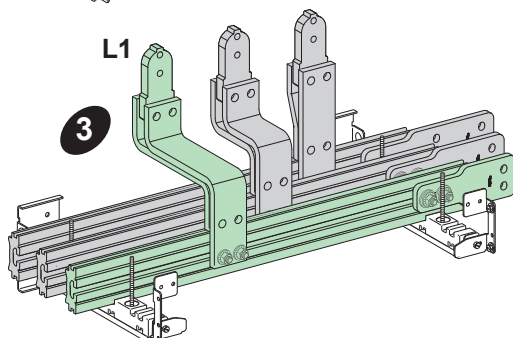
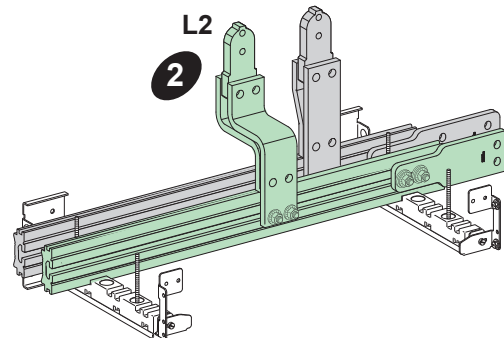
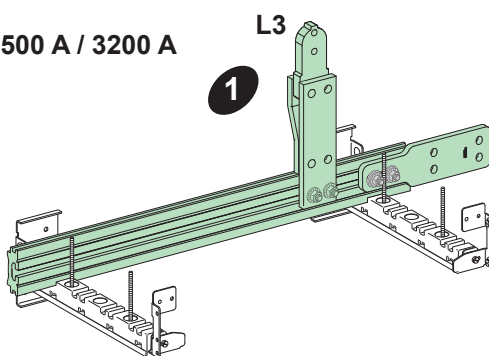
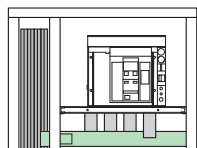
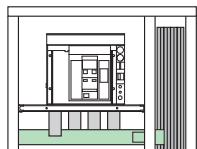

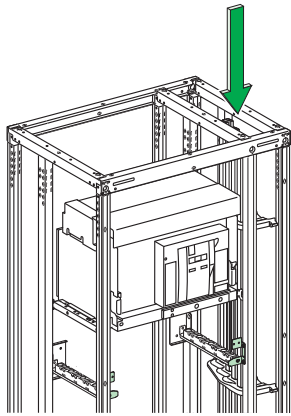

1600 A

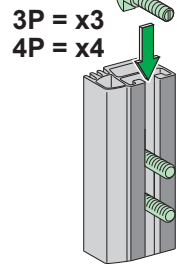

2500 A

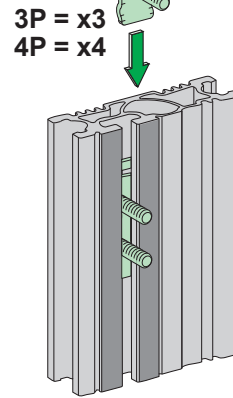

3200 A

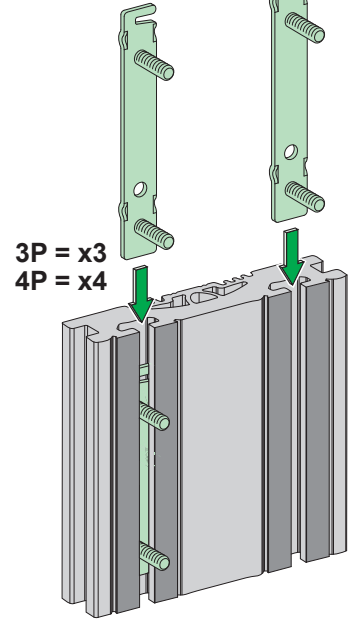

04683
3P

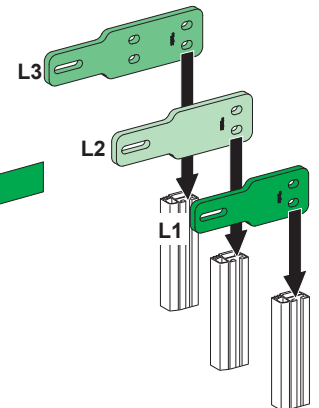
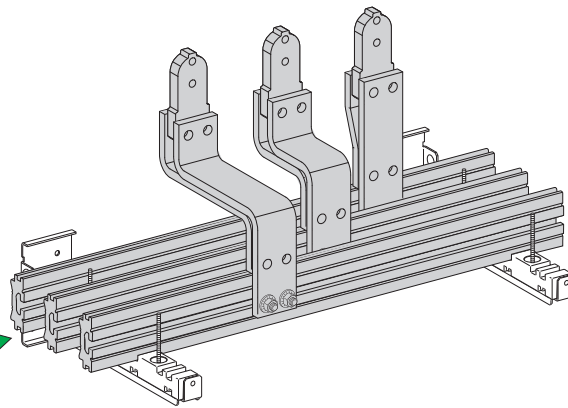
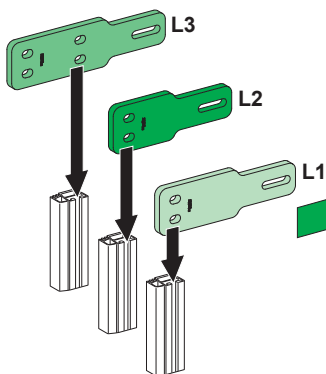

	NW 08/16A	NW 20/25A	NW 32A	NW 08/16A	NW 20/25A	NW 32A
	5 m	5 m	6 m	5 m	5 m	6 m
	NW16-FIX-CON	NW25-FIX-CON	NW32-FIX-CON	NW16-DRW-CON	NW25-DRW-CON	NW32-DRW-CON



1600 A

3P
04493 + 04683
4P
04494 + 04684

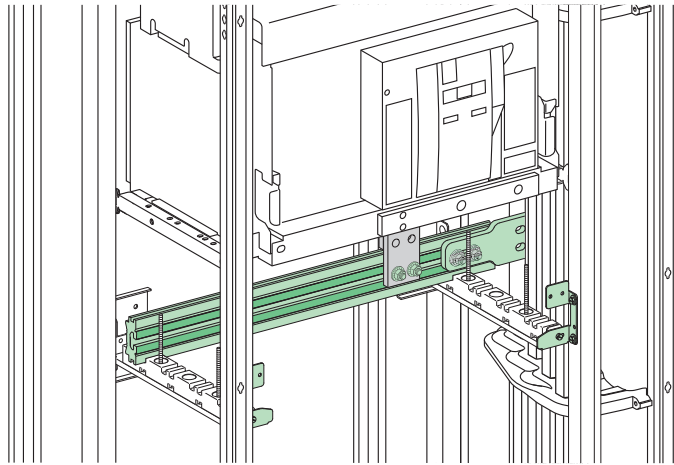

1600 A → L3/L2/L1/N

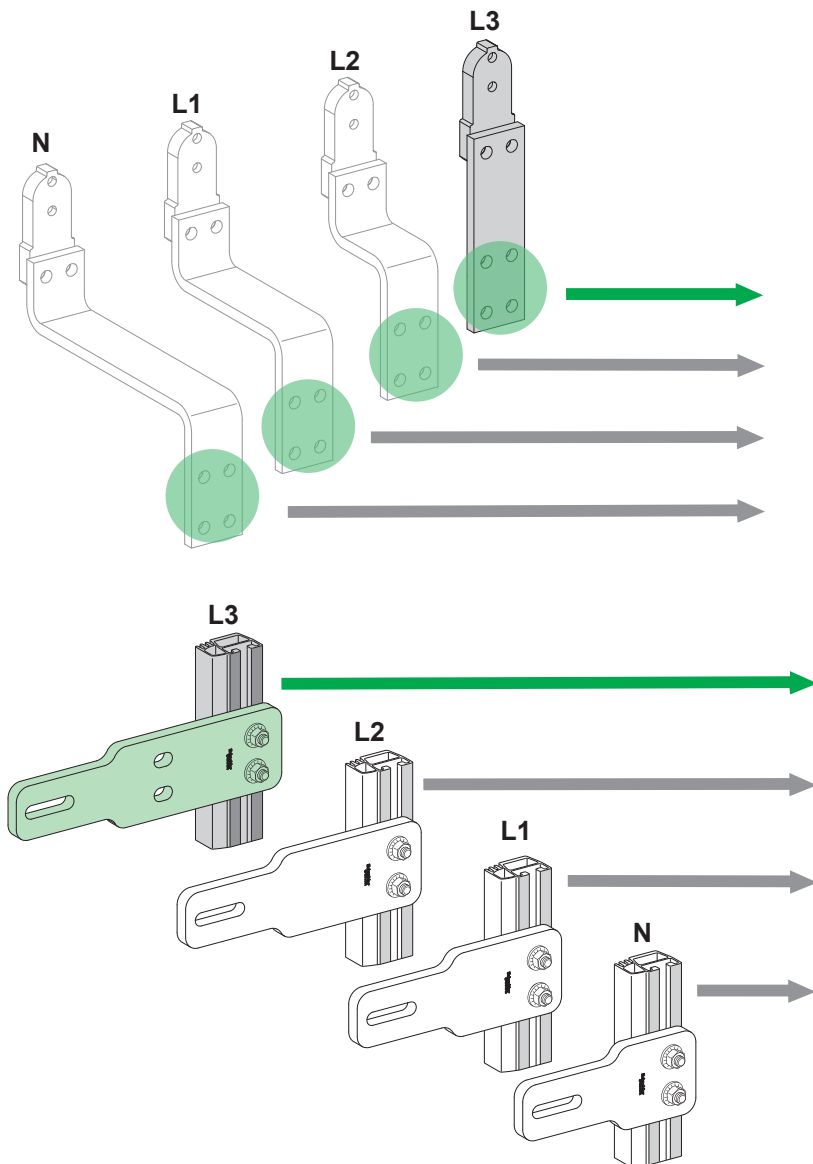
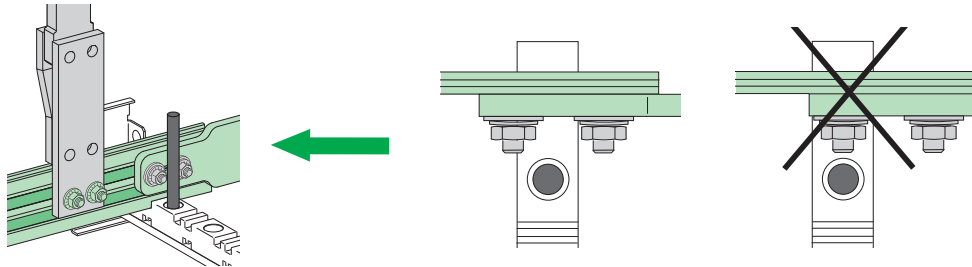
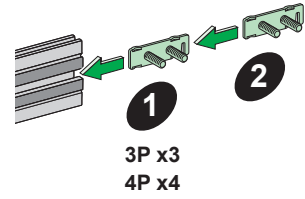

1600 A

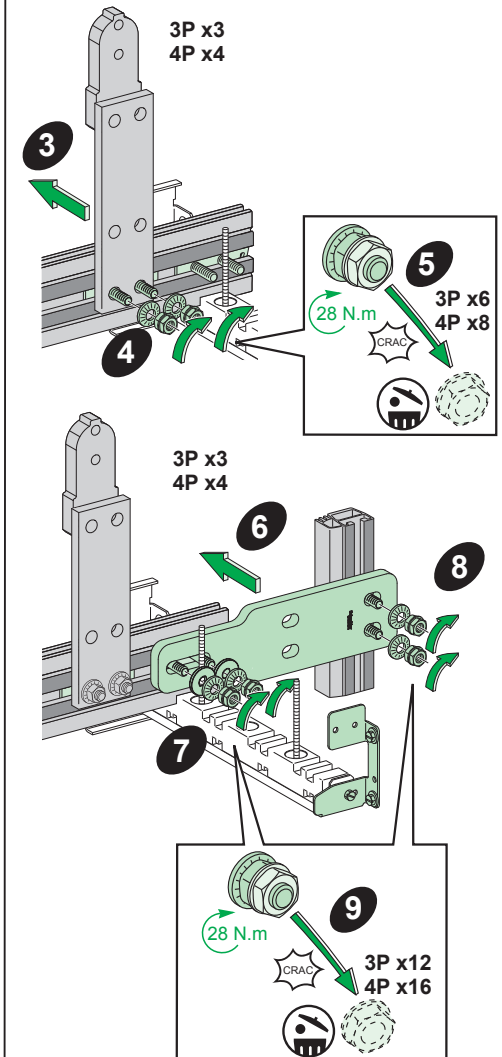



2500 A

3P
04495 + 04685 x3
4P
04496 + 04685 x4

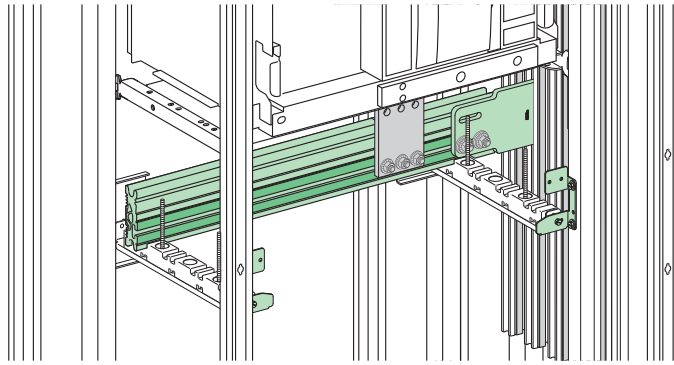

2500 A → L3/L2/L1/N

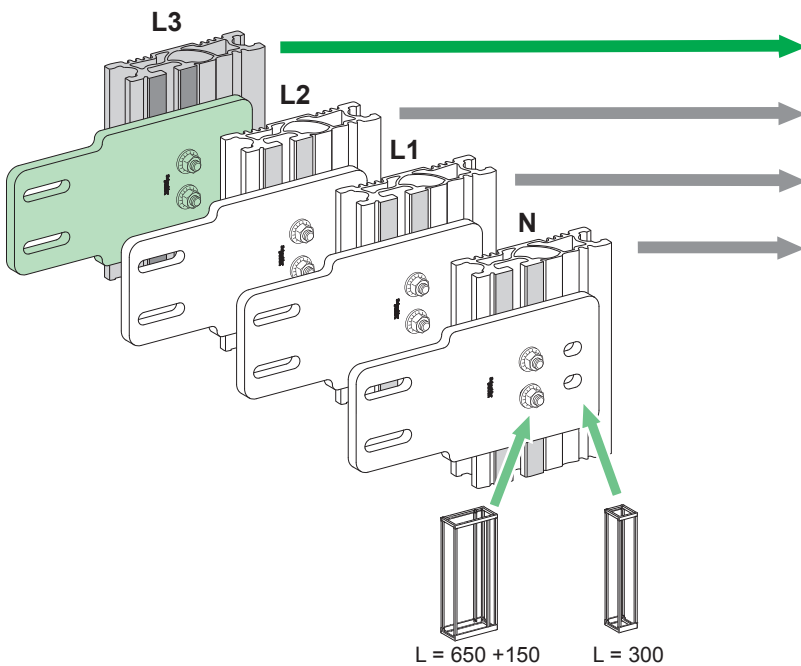
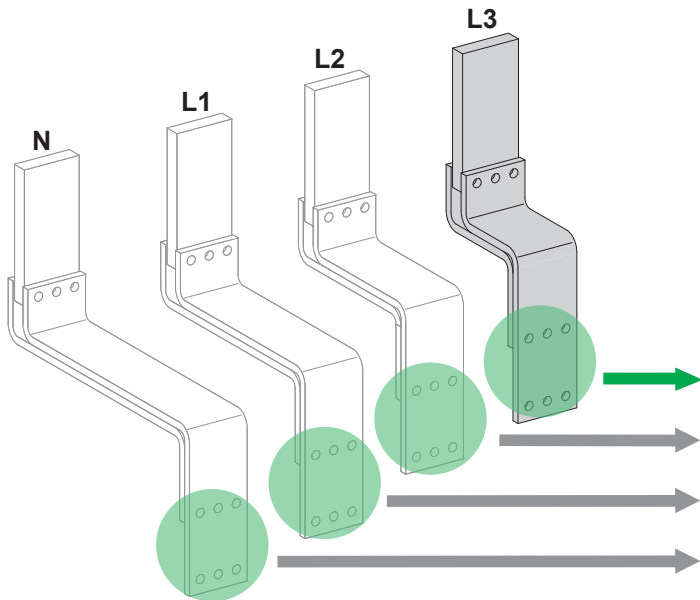
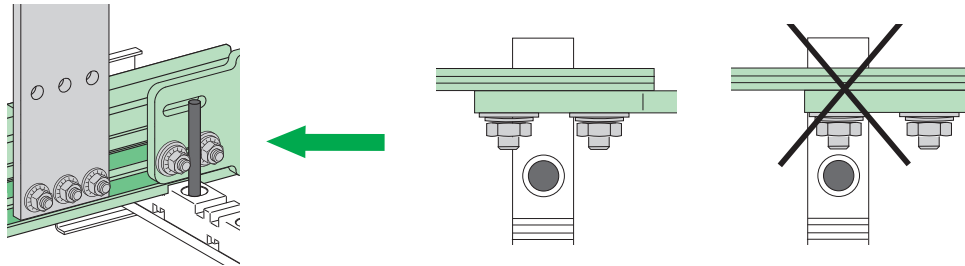
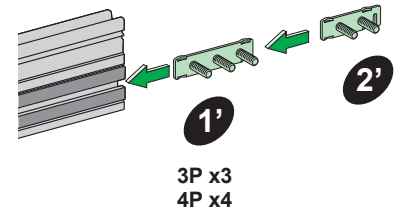

2500 A

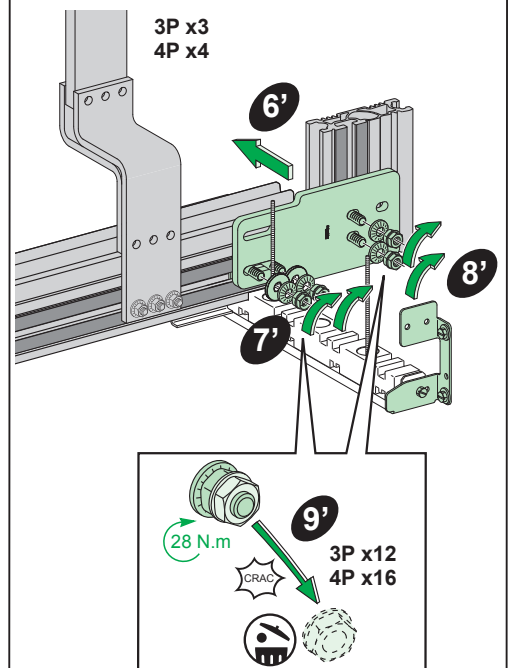
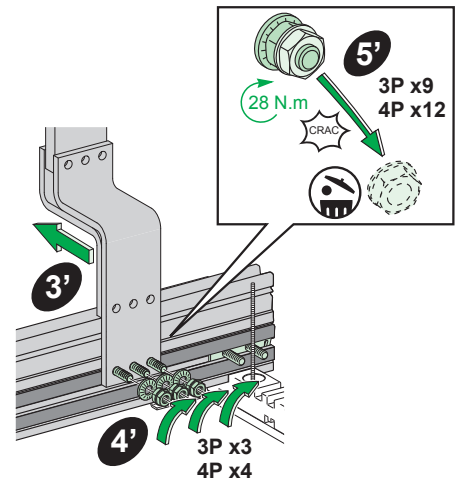

D''

3200 A

3200 A → L3/L2/L1/N

3P
04497 + 04687 x3
4P
04498 + 04687 x4

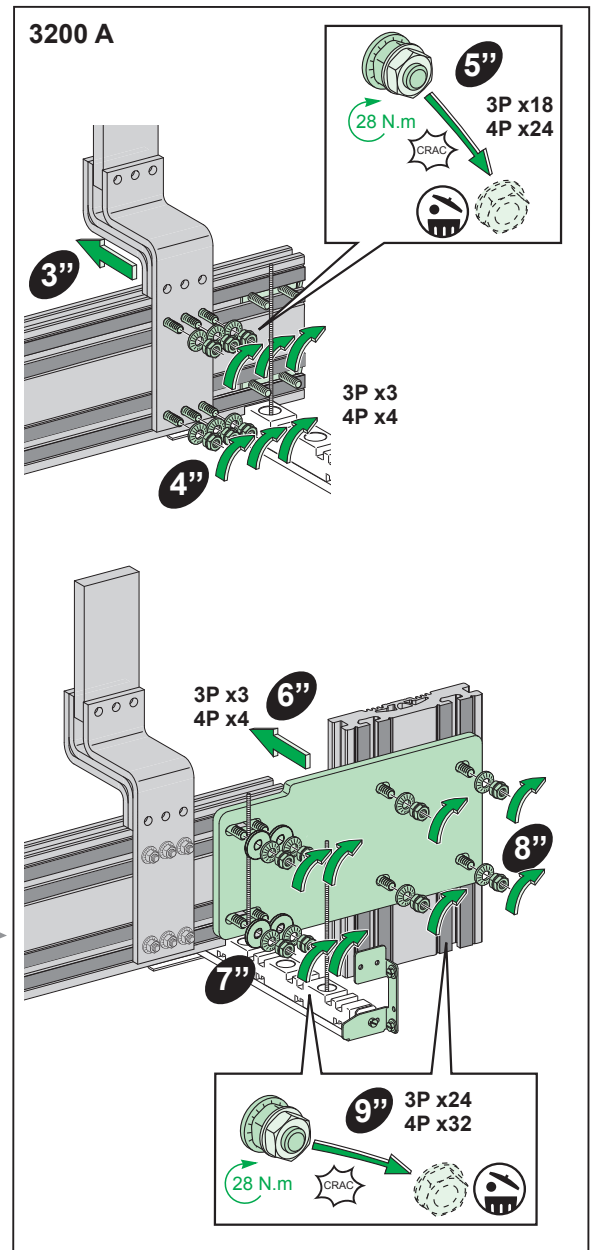
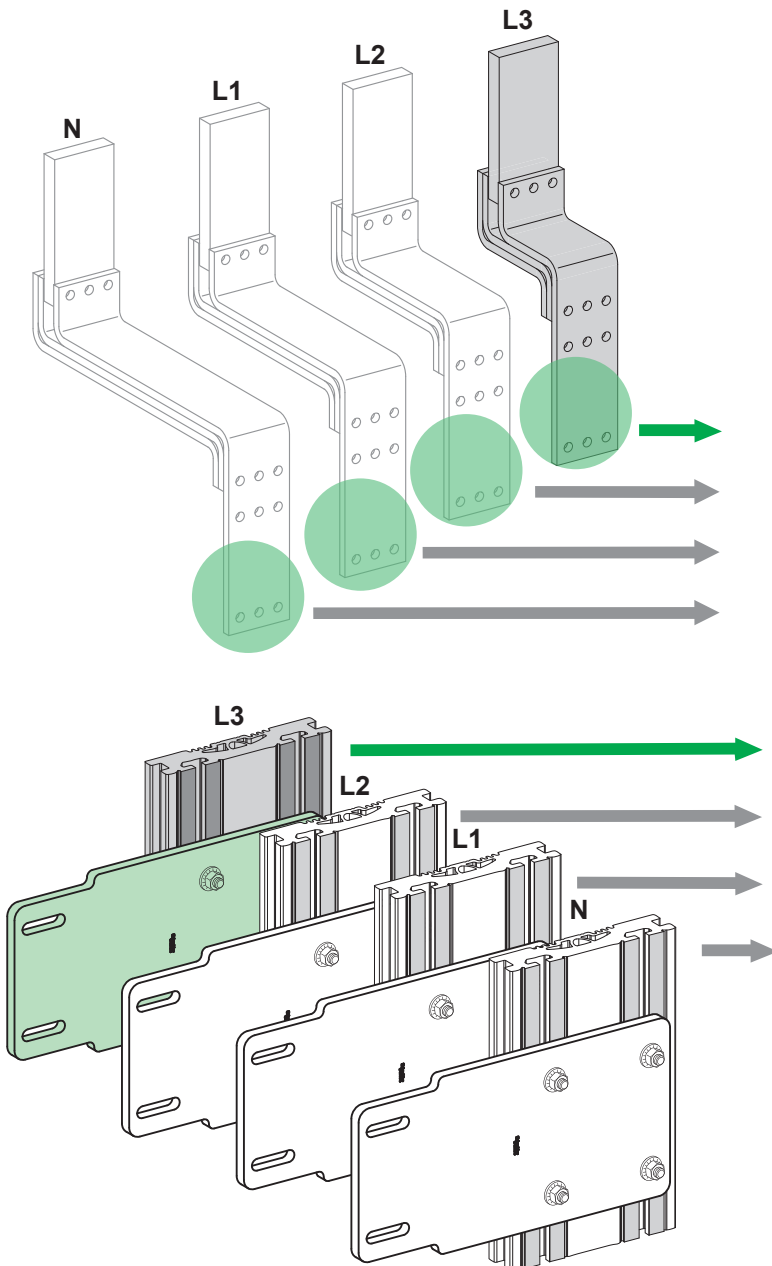
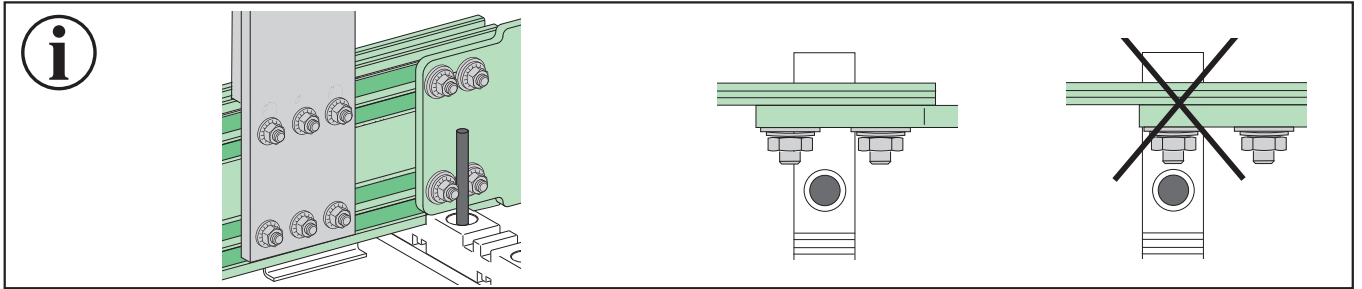
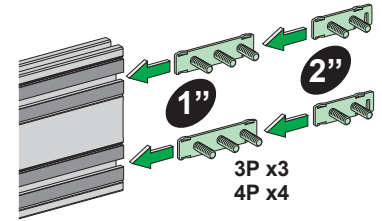
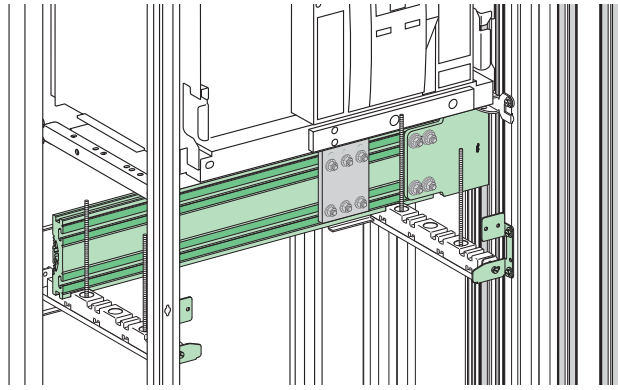



630 A
↓
1600 A

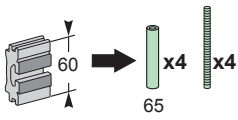

2000 A
↓
2500 A

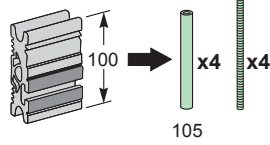

3200 A
↓
4000 A

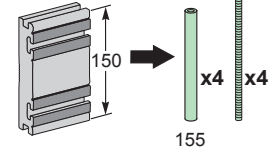

E

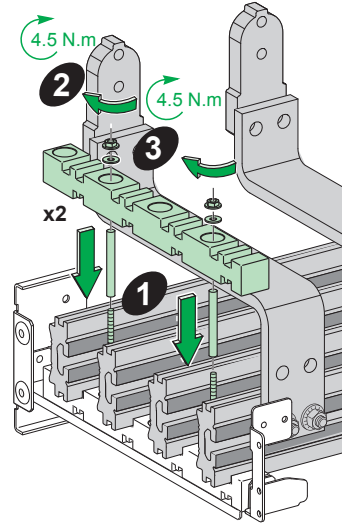
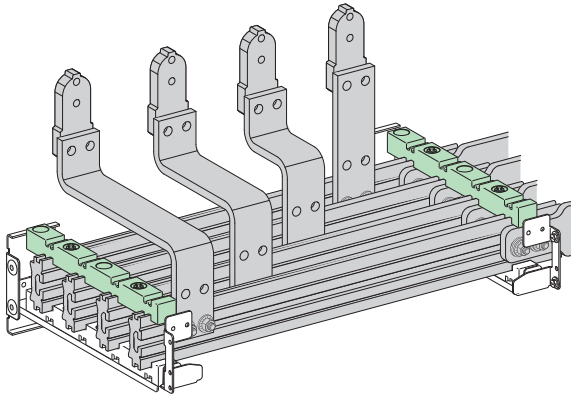

F

4P

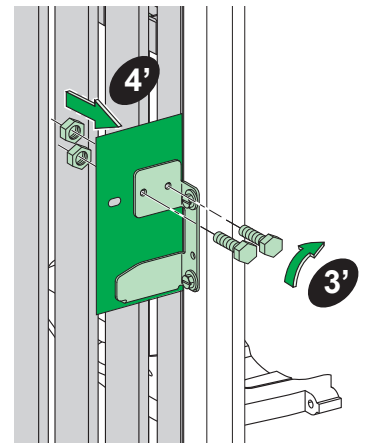
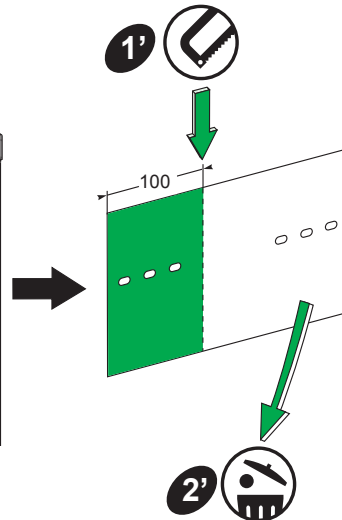
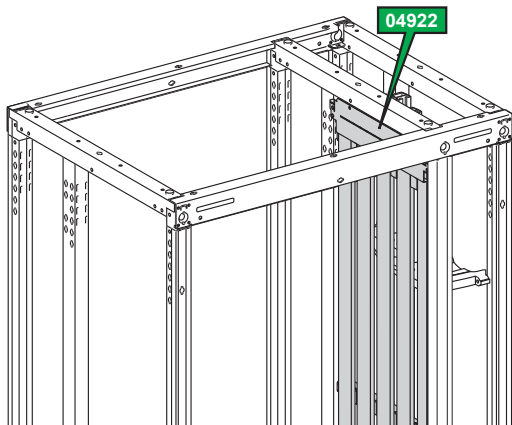
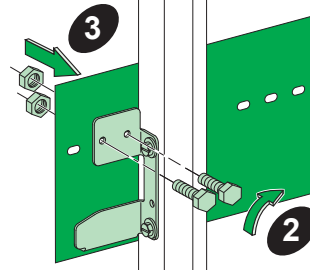
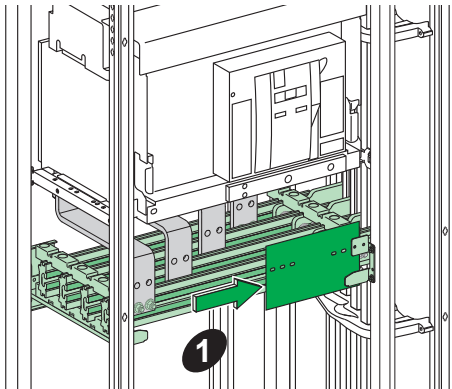

NW16-FIX-CON

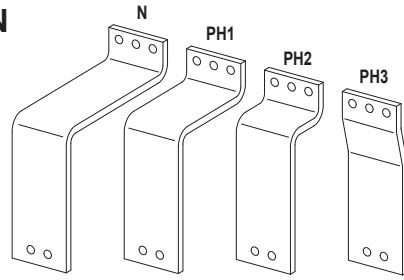

Phase	C	X
N	211.75	374.166
PH1	136.75	299.166
PH2	61.75	224.166
PH3	---	181.741

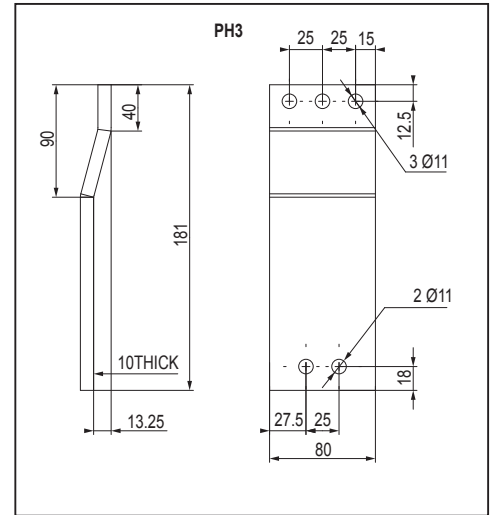
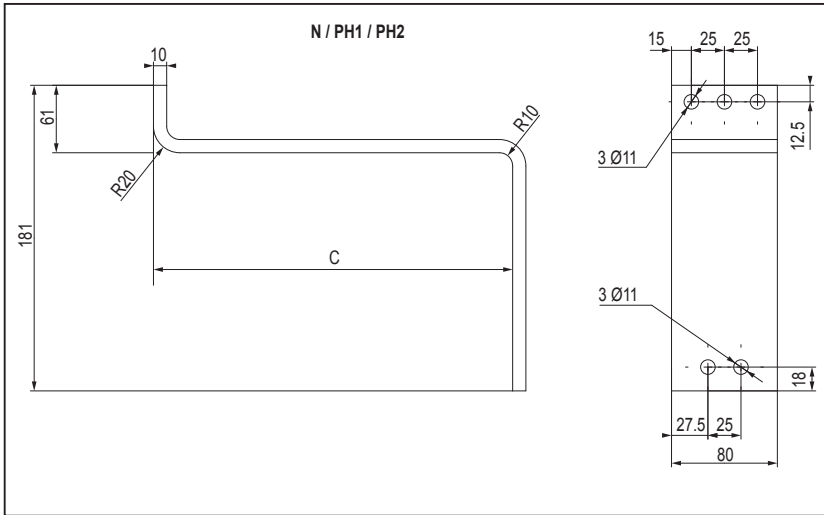
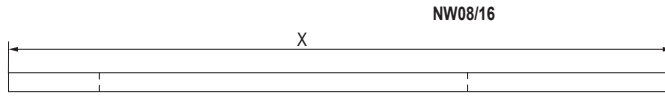

NW25-FIX-CON

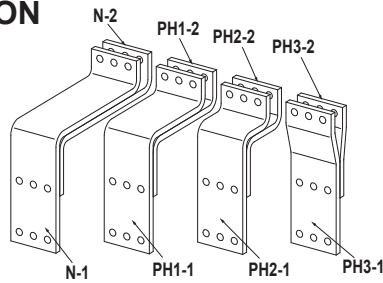

Phase	A (PH* - 2)	C (PH* - 1)	X (PH* - 2)	X (PH* - 1)
N	231.75	211.75	306.166	374.166
PH1	156.75	136.75	231.166	299.166
PH2	81.75	61.75	156.166	224.166
PH3	---	---	92.891	182.227

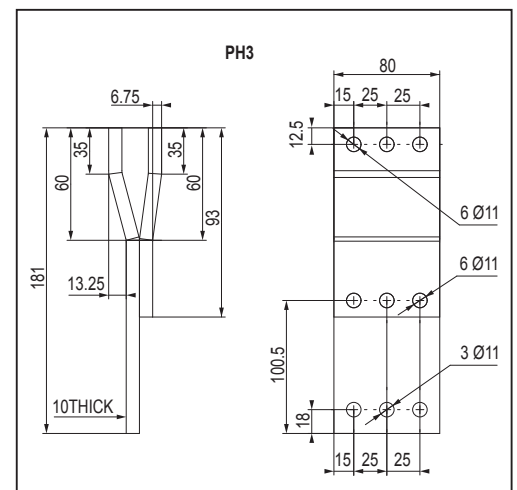
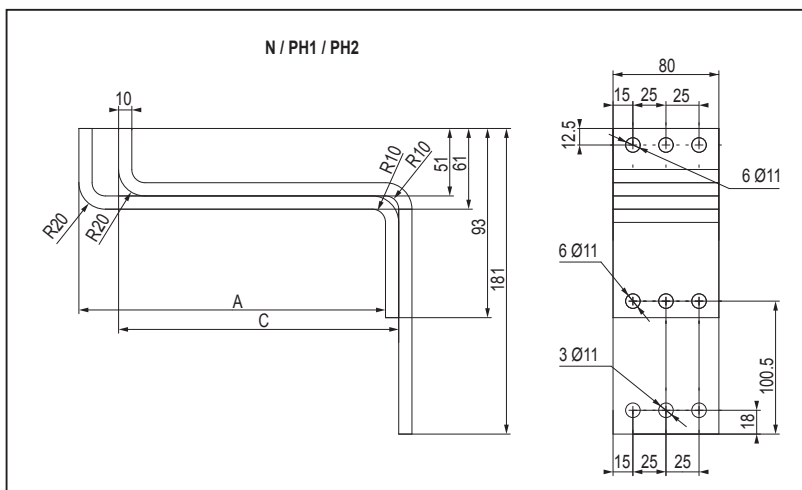
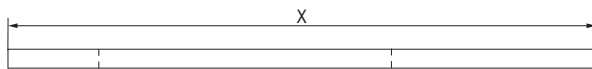

NW32-FIX-CON

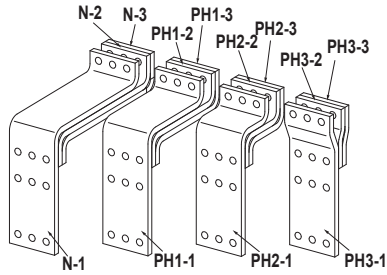

Phase	A (PH* - 3)	B (PH* - 2)	C (PH* - 1)	X (PH* - 3)	X (PH* - 2)	X (PH* - 1)
N	231.75	231.75	211.75	306.166	306.166	424.166
PH1	156.75	156.75	136.75	231.166	231.166	349.166
PH2	81.75	81.75	81.75	156.166	156.166	274.166
PH3	---	---	---	92.838	92.719	231.101

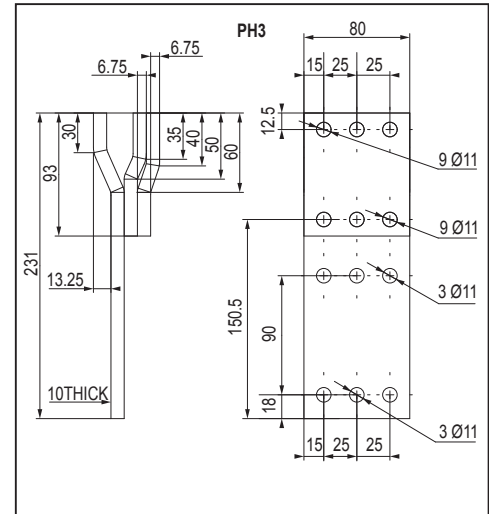
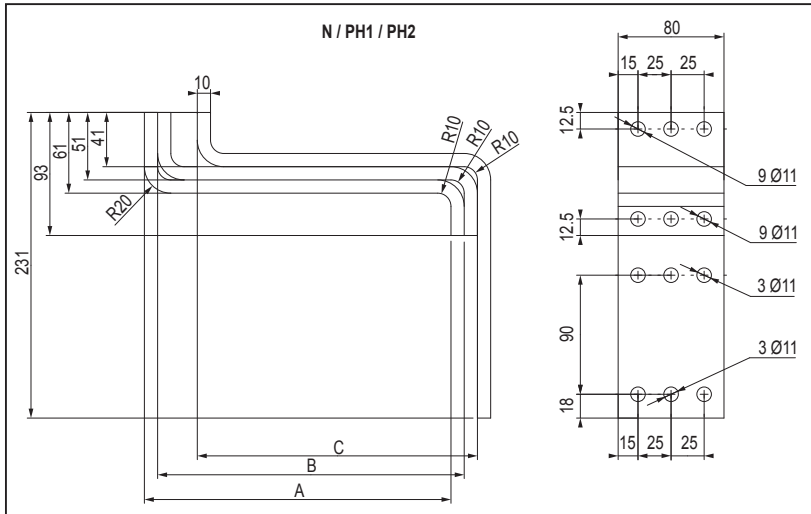
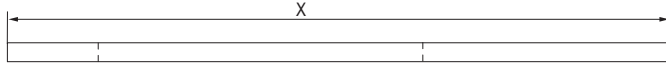

NW16-DRW-CON

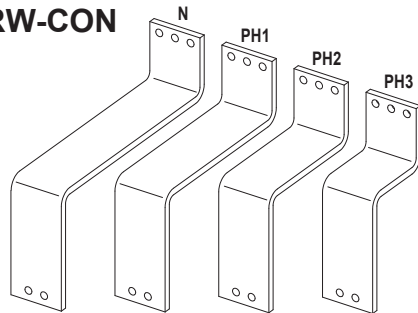

Phase	A	X
N	328	521.916
PH1	253	446.916
PH2	178	371.916
PH3	103	296.916

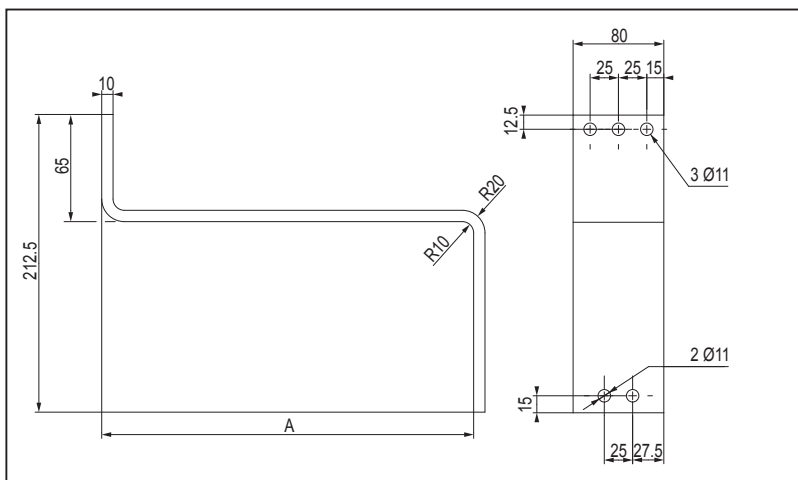
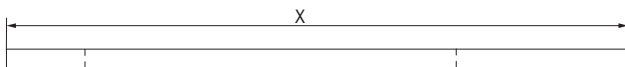

NW25-DRW-CON

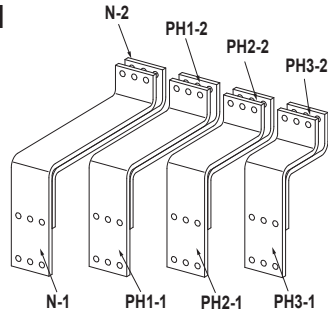

Phase	A (PH* - 2)	C (PH* - 1)	X (PH* - 2)	X (PH* - 1)
N	348.5	328.5	457.916	525.916
PH1	273.5	253.5	382.916	450.916
PH2	198.5	178.5	307.916	375.916
PH3	123.5	103.5	232.916	300.916

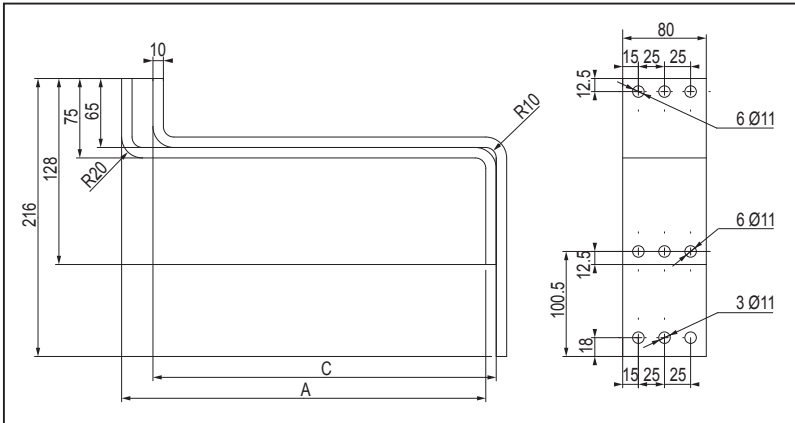
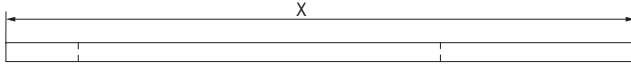

NW32-DRW-CON

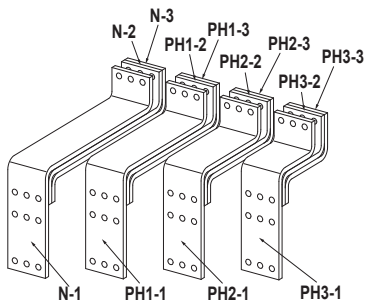

Phase	A (PH* - 3)	C (PH* - 2)	E (PH* - 1)	X (PH* - 3)	X (PH* - 2)	X (PH* - 1)
N	348.5	348.5	328.5	457.916	457.916	575.916
PH1	273.5	273.5	253.5	382.916	382.916	500.916
PH2	198.5	198.5	178.5	307.916	307.916	425.916
PH3	123.5	123.5	103.5	232.916	232.916	350.916

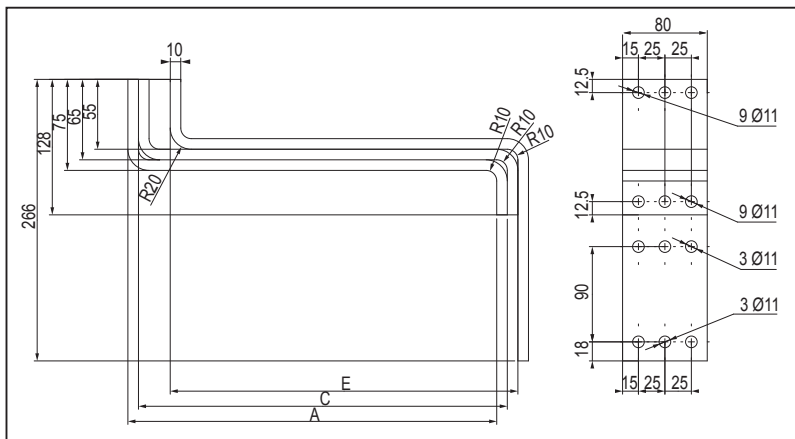
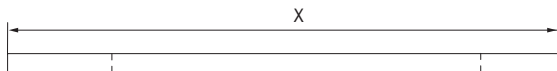

Schneider Electric Industries SAS

35, rue Joseph Monier
92500 Rueil-Malmaison
France

<http://www.schneider-electric.com>

NHA64164 - A0

En raison de l'évolution des normes et du matériel, les caractéristiques indiquées par le texte et les images de ce document ne nous engagent qu'après confirmation par nos services.

As standards, specifications and designs change from time to time, please ask for confirmation of the information given in this publication.

Publication : Schneider Electric
Réalisation :
Impression :
Format de pliage : 210 x 297 mm



Ce document a été imprimé sur du papier écologique.

This document has been printed on ecological paper.

12/2016