

TeSys Active

TeSys Tera Motor Management System

User Guide

TeSys offers innovative and connected solutions for motor starters.

DOCA0257EN-01
11/2025



Legal Information

The information provided in this document contains general descriptions, technical characteristics and/or recommendations related to products/solutions.

This document is not intended as a substitute for a detailed study or operational and site-specific development or schematic plan. It is not to be used for determining suitability or reliability of the products/solutions for specific user applications. It is the duty of any such user to perform or have any professional expert of its choice (integrator, specifier or the like) perform the appropriate and comprehensive risk analysis, evaluation and testing of the products/solutions with respect to the relevant specific application or use thereof.

The Schneider Electric brand and any trademarks of Schneider Electric SE and its subsidiaries referred to in this document are the property of Schneider Electric SE or its subsidiaries. All other brands may be trademarks of their respective owner.

This document and its content are protected under applicable copyright laws and provided for informative use only. No part of this document may be reproduced or transmitted in any form or by any means (electronic, mechanical, photocopying, recording, or otherwise), for any purpose, without the prior written permission of Schneider Electric.

Schneider Electric does not grant any right or license for commercial use of the document or its content, except for a non-exclusive and personal license to consult it on an "as is" basis.

Schneider Electric reserves the right to make changes or updates with respect to or in the content of this document or the format thereof, at any time without notice.

To the extent permitted by applicable law, no responsibility or liability is assumed by Schneider Electric and its subsidiaries for any errors or omissions in the informational content of this document, as well as any non-intended use or misuse of the content thereof.

Table of Contents

Safety Information.....	7
About the Document.....	8
Precautions.....	12
Introducing the TeSys Tera Motor Management System.....	14
Presentation of TeSys Tera Motor Management System.....	15
TeSys Master Range.....	16
TeSys Tera System.....	17
Technical Characteristics.....	20
Components of TeSys Tera System.....	22
Load Current Transformers.....	29
Ground Current Transformers.....	30
Description of TeSys Tera Motor Management System.....	31
LTMT Main Unit.....	32
Communication Ports.....	37
LTMTCT/LTMTCTV Sensor Module.....	39
LTMT Expansion Module.....	40
LTMTCUF Control Operator Unit.....	43
Settings of TeSys Tera Motor Management System.....	45
Name Plate.....	46
Device Configuration.....	48
System Settings.....	50
Metering Functions.....	53
Overview.....	54
Current Measurement.....	55
RMS Current.....	56
Ground Current.....	57
Average Current.....	58
Current Imbalance.....	59
Current Phase Sequence.....	60
Voltage Measurement.....	61
Overview.....	62
RMS Voltage.....	62
Average Voltage.....	63
Voltage Imbalance.....	64
Voltage Phase Sequence.....	65
Frequency.....	66
Power and Energy Measurement.....	67
Overview.....	68
Active Power, Reactive Power, and Apparent Power.....	68
Active Energy, Reactive Energy, and Apparent Energy.....	69
Power Factor.....	70
THD Metering for Current and Voltage.....	72
Temperature Measurement.....	73
Analog Input Measurement.....	74
Monitoring Functions.....	76
Overview.....	77
Thermal Memory.....	78

Thermal Time to Trip	79
Thermal Time to Cool.....	80
Motor History.....	81
Motor Status	83
Inhibit Status	84
System Self-Diagnostic.....	86
Test Functions	87
Communication Loss	90
HMI Communication Loss	91
Monitoring Records	92
Protection Functions.....	94
Protection Settings	95
Function Parameter	96
Reset Modes	98
Hysteresis Setting	99
Motor Protection Functions.....	100
Thermal Overload	101
Locked Rotor.....	107
Stall Rotor	108
Temperature Protection	109
Current Protection Functions	110
Definite Time Overcurrent.....	111
Normal Inverse Overcurrent.....	112
Short Time Overcurrent	113
Phase Under Current	115
Calculated Ground Trip	116
Measured Ground Trip	117
Current Imbalance	118
Current Phase Reversal	119
Current Phase Loss	120
Voltage Protection Functions	121
Phase Under Voltage	122
Phase Over Voltage	123
Voltage Imbalance	124
Voltage Phase Reversal	125
Voltage Phase Loss	126
Power Protection Functions.....	127
Over Frequency.....	128
Under Frequency	129
Over Power	130
Under Power	131
Under Power Factor	132
Digital Input Interlock	133
Analog Input Protection.....	134
AO Settings.....	135
Motor Control Functions.....	136
Motor Control Station	137
Overview.....	138
Working Principle of the Motor Starters	138
Motor Starter Settings	140
Operating Modes	146

Digital Inputs	148
Digital Outputs	151
Motor Starter Functions.....	153
Overload	154
Direct Online	155
Reverse Direct Online	159
Star Delta	162
Forced Start Function.....	165
Single Phase Motor Application.....	166
Motor Control Function.....	169
Maximum Number of Starts	170
Voltage Dip Management	171
Load Shedding	172
Auto Restart	174
Anti-Backspin Timer	180
Stop Error Detection.....	181
Block Output.....	183
Device internal protection	184
Appendices	185
Trip Code	186
Event Code	188
Device Internal Error Code	206
Input Source	208

Safety Information

Important Information

Read these instructions carefully, and look at the equipment to become familiar with the device before trying to install, operate, service, or maintain it. The following special messages may appear throughout this documentation or on the equipment to warn of potential hazards or to call attention to information that clarifies or simplifies a procedure.



The addition of this symbol to a “Danger” or “Warning” safety label indicates that an electrical hazard exists which will result in personal injury if the instructions are not followed.



This is the safety alert symbol. It is used to alert you to potential personal injury hazards. Obey all safety messages that follow this symbol to avoid possible injury or death.

DANGER

DANGER indicates a hazardous situation which, if not avoided, **will result in death or serious injury**.

WARNING

WARNING indicates a hazardous situation which, if not avoided, **could result in death or serious injury**.

CAUTION

CAUTION indicates a hazardous situation which, if not avoided, **could result in minor or moderate injury**.

NOTICE

NOTICE is used to address practices not related to physical injury.

Please Note

Electrical equipment should be installed, operated, serviced, and maintained only by qualified personnel. No responsibility is assumed by Schneider Electric for any consequences arising out of the use of this material.

A qualified person is one who has skills and knowledge related to the construction and operation of electrical equipment and its installation, and has received safety training to recognize and avoid the hazards involved.

About the Document

Document Scope

This guide provides complete information necessary to use the TeSys™ Tera system which includes:

- LTMT main unit
- LTMTCT/LTMTCTV sensor modules
- LTMT expansion module
- LTMTCUF control operator unit

The purpose of this guide is to:

- Provide information necessary to configure and operate the TeSys Tera system and its components
- Describe the metering, monitoring, protection, and control functions of the TeSys Tera system

This guide is intended for:

- Design engineers
- System integrators
- System operators

Validity Note

This document is valid for the following certified components of the TeSys Tera system:

Commercial Reference	Description	Range
LTMTEFM	LTMT main unit with EtherNet/IP or Modbus TCP/IP protocol	100–240 Vac/Vdc
LTMTEBD	LTMT main unit with EtherNet/IP or Modbus TCP/IP protocol	24 Vdc
LTMTMFM	LTMT main unit with Modbus RTU protocol	100–240 Vac/Vdc
LTMTMBD	LTMT main unit with Modbus RTU protocol	24 Vdc
LTMTPFM	LTMT main unit with PROFIBUS DP protocol	100–240 Vac/Vdc
LTMTPBD	LTMT main unit with PROFIBUS DP protocol	24 Vdc
LTMTCT3T	LTMT horizontal sensor module with current transformer	Current range = 0.3–3 A
LTMTCT25T	LTMT horizontal sensor module with current transformer	Current range = 2.5–25 A
LTMTCT100T	LTMT horizontal sensor module with current transformer	Current range = 10–100 A
LTMTCTV3T	LTMT horizontal sensor module with current and voltage transformers	<ul style="list-style-type: none"> • Current range = 0.3–3 A • Voltage range = 60–690 Vac

LTMTCTV25T	LTMT horizontal sensor module with current and voltage transformers	<ul style="list-style-type: none"> Current range = 2.5–25 A Voltage range = 60–690 Vac
LTMTCTV100T	LTMT horizontal sensor module with current and voltage transformers	<ul style="list-style-type: none"> Current range = 10–100 A Voltage range = 60–690 Vac
LTMTCTV3UT	LTMT horizontal sensor module with current and voltage transformers	<ul style="list-style-type: none"> Current range = 0.3–3 A Voltage range = 60–600 Vac
LTMTCTV25UT	LTMT horizontal sensor module with current and voltage transformers	<ul style="list-style-type: none"> Current range = 2.5–25 A Voltage range = 60–600 Vac
LTMTCTV100UT	LTMT horizontal sensor module with current and voltage transformers	<ul style="list-style-type: none"> Current range = 10–100 A Voltage range = 60–600 Vac
LTMTIN42FM	LTMT expansion module with four digital inputs and two digital outputs	<ul style="list-style-type: none"> 100–265 Vac/dc for IEC 110–240 Vac/dc for UL
LTMTIN42BD	LTMT expansion module with four digital inputs and two digital outputs	24 Vdc
LTMTAN21	LTMT expansion module with two analog inputs and one analog output	4–20 mA
LTMT9RJ1015	LTMT main unit to LTMTCT/ LTMTCTV sensor module RJ11 connector cable	0.15 m (5.9 in) in length
LTMT9RJ105	LTMT main unit to LTMTCT/ LTMTCTV sensor module RJ11 connector cable	0.5 m (19.6 in) in length
LTMTCUF	LTMTCUF control operator unit	–
LTMT9RJ102	LTMT main unit to LTMTCT/ LTMTCTV sensor module cable	0.2 m (7.874 in) in length
LTMT9RJ401	LTMT main unit to LTMT expansion module RJ45 connector cable	0.1 m (3.9 in) in length
LTMT9EX10	LTMT main unit to LTMT expansion module cable	1 m (39.37 in) in length
LTMT9CU10S	LTMT main unit to LTMTCUF control operator unit	1 m (39.37 in) in length
LTMT9CU30S	LTMT main unit to LTMTCUF control operator unit	3 m (118.11 in) in length

The availability of some functions described in this document depends on the communication protocol used and the physical modules installed on the TeSys Tera system.

General Cybersecurity Information

In recent years, the growing number of networked machines and production plants has seen a corresponding increase in the potential for cyber threats, such as unauthorized access, data breaches, and operational disruptions. You must, therefore, consider all possible cybersecurity measures to help protect assets and systems against such threats.

To help keep your Schneider Electric products secure and protected, it is in your best interest to implement the cybersecurity best practices as described in the [Cybersecurity Best Practices](#) document.

Schneider Electric provides additional information and assistance:

- [Subscribe to the Schneider Electric security newsletter.](#)
- [Visit the Cybersecurity Support Portal web page to:](#)
 - [Find Security Notifications.](#)
 - [Report vulnerabilities and incidents.](#)
- [Visit the Schneider Electric Cybersecurity and Data Protection Posture web page to:](#)
 - [Access the cybersecurity posture.](#)
 - [Learn more about cybersecurity in the cybersecurity academy.](#)
 - [Explore the cybersecurity services from Schneider Electric.](#)

Product Related Cybersecurity Information

Refer to *TeSys Tera Motor Management System Cybersecurity Guide – DOCA0260EN*.

Environmental Data

For product compliance and environmental information, refer to the Schneider Electric Environmental Data Program.

Available Languages of the Document

The document is available in these languages:

- English
- Chinese
- French
- German
- Italian
- Korean
- Spanish

Related Documents

Title of documentation	Description	Reference number
TeSys Tera Motor Management System Catalog	The catalog <ul style="list-style-type: none"> • Describes the TeSys Tera system • Contains the TeSys Tera technical characteristics 	LVCATENTER
TeSys Tera Motor Management System Installation Guide	This guide describes the installation, commissioning, and maintenance of the LTMT main unit, LTMTCT/LTMTCTV sensor modules, LTMT expansion module, and LTMTCUF control operator unit.	DOCA0356EN
TeSys Tera Motor Management System Modbus RTU Communication Guide	This guide describes the Modbus RTU network protocol communication of the LTMT main unit.	DOCA0355EN
TeSys Tera Motor Management System PROFIBUS DP Communication Guide	This guide describes the PROFIBUS DP network protocol communication of the LTMT main unit.	DOCA0256EN
TeSys Tera Motor Management System LTMTCUF User Guide	This guide describes how to install, configure, and use the LTMTCUF control operator unit.	DOCA0233EN
TeSys Tera Motor Management System DTM Library Online Help Guide	This guide describes the TeSys Tera DTM library which allows the customization of the control functions of the TeSys Tera Motor Management System.	DOCA0275EN
TeSys Tera Motor Management System DTM Library Release Note	This document provides important information about the TeSys Tera DTM	DOCA0279EN
TeSys Tera Motor Management System Firmware Release Note	This guide provides important information about the TeSys Tera system firmware packages and provides summary of new features and enhancement.	DOCA0276EN
TeSys Tera Motor Management System EtherNet/IP Communication Guide	This guide describes the EtherNet/IP network protocol communication of the LTMT main unit.	DOCA0258EN
TeSys Tera Motor Management System Cybersecurity Guide	This guide provides information on cybersecurity aspects for the TeSys Tera Motor Management System. This guide addresses on how to secure your operational technology network, or your company serial or Ethernet network.	DOCA0260EN

To find documents online, visit the Schneider Electric download center (www.se.com/ww/en/download/).

Information on Non-Inclusive or Insensitive Terminology

As a responsible, inclusive company, Schneider Electric is constantly updating its communications and products that contain non-inclusive or insensitive terminology. However, despite these efforts, our content may still contain terms that are deemed inappropriate by some customers.

Trademarks

QR Code is a registered trademark of DENSO WAVE INCORPORATED in Japan and other countries.

Precautions

Read and understand the following precautions before performing any procedures in this guide.

⚡⚠ DANGER
HAZARD OF ELECTRIC SHOCK, EXPLOSION, OR ARC FLASH
<ul style="list-style-type: none">• This equipment must only be installed and serviced by qualified electrical personnel.• Turn off all power supplying to this equipment before working on this equipment.• Use only the specified voltage when operating this equipment and any associated products.• Always use a properly rated voltage sensing device to confirm power is off.• Use appropriate interlocks where personnel and/or equipment hazards exist.• Power line circuits must be wired and protected in compliance with local and national regulatory requirements.• Apply appropriate personal protective equipment (PPE) and follow safe electrical work practices per NFPA 70E, NOM-029-STPS, or CSA Z462 or local equivalent.
Failure to follow these instructions will result in death or serious injury.

⚠ WARNING
UNINTENDED EQUIPMENT OPERATION
<ul style="list-style-type: none">• Do not disassemble, repair, or modify this equipment. There are no user serviceable parts.• Install and operate this equipment in an enclosure appropriately rated for its intended application environment.• Each implementation of this equipment must be individually and thoroughly tested for proper operation before being placed into service.
Failure to follow these instructions can result in death, serious injury, or equipment damage.

California Proposition 65 Warning



WARNING: This product can expose you to chemicals such as, Humiseal 1A33 Polyurethane, which is known to the State of California to cause cancer and birth defects or other reproductive harm. For more information go to www.P65Warnings.ca.gov.

Qualified Personnel

Only appropriately trained personnel who are familiar with and understand the content of this guide and all other related product documentation are authorized to work on and with this product.

The qualified personnel must be able to detect possible hazards that may arise from modifying parameter values and generally from mechanical, electrical, or electronic equipment. The qualified personnel must be familiar with the standards, provisions, and regulations for the prevention of industrial accidents, which they must observe when designing and implementing the system.

The use and application of the information contained in this guide requires expertise in the design and programming of automated control systems. Only you,

the user, panel builder, or integrator, can be aware of all the conditions and factors present during installation, setup, operation, and maintenance of a process plant or machine, and can therefore determine the automation and associated equipment and the related safeties and interlocks which can be effectively and properly used when selecting automation and control equipment, and any other related equipment or software, for a particular application. You must also consider applicable local, regional, or national standards and/or regulations.

Pay particular attention to conformance with any safety information, electrical requirements, and normative standards that apply to your process plant or machine in the use of this equipment.

Intended Use

The products described in this guide, together with software, accessories, and options, are a part of starters for low-voltage electrical loads, intended for industrial use according to the instructions, directions, examples, and safety information contained in the present document and other supporting documentation.

The product may only be used in compliance with all applicable safety regulations and directives, the specified requirements, and the technical data.

Before using the product, you must perform a risk assessment of the planned application. Based on the results, appropriate safety-related measures must be implemented.

Since the product is used as a component of a process plant or machine, you must ensure the safety of personnel by means of the overall system design.

Operate the product only with the specified cables and accessories. Use only genuine accessories and spare parts.

Any use other than the use explicitly permitted is prohibited and can result in unanticipated hazards.

Introducing the TeSys Tera Motor Management System

What's in This Part

Presentation of TeSys Tera Motor Management System.....	15
Description of TeSys Tera Motor Management System	31
Settings of TeSys Tera Motor Management System	45

Presentation of TeSys Tera Motor Management System

What's in This Chapter

TeSys Master Range	16
TeSys Tera System.....	17
Technical Characteristics	20
Components of TeSys Tera System	22
Load Current Transformers	29
Ground Current Transformers	30

TeSys Master Range

TeSys is an innovative motor control, monitoring, and management solution from the global market leader. TeSys offers connected, efficient products, solutions for switching, protection of motors and electrical loads in compliance with all major global electrical standards.

TeSys Tera System

Overview

The TeSys Tera Motor Management System (TeSys Tera system) is part of the TeSys Active range of intelligent relays and motor starters. The TeSys Tera system is designed as a reliable building block for Intelligent Motor Control Centres (iMCCs) to provide complete protection, metering, control, and monitoring capabilities for single-phase or three-phase AC induction motors.

The TeSys Tera system is installed in the low voltage switchgear system and connects the higher level automation system through fieldbus network and the motor feeder.

TeSys Tera system:

- Covers conventional and advanced motor protection, metering, and monitoring in iMCC feeders into single, easy to configure, compact communicating module with a standalone HMI device.
- Provides protection controller for low voltage contactor-controlled motor starter feeders.
- Provides flexible and modular motor management system for motors with constant speeds in low voltage applications.

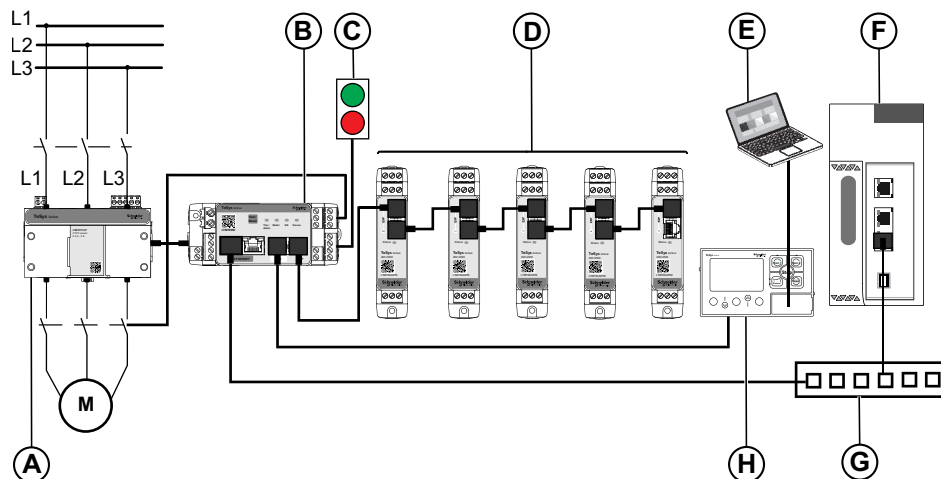

- A LTMTCT/LTMTCTV sensor module
- B LTMT main unit
- C Start/Stop commands
- D LTMT expansion modules
- E PC running SoMove FDT container software with TeSys Tera DTM installed and equipped with standard web server capability
- F Programmable Logic Controller (PLC) or Distributed Control System (DCS)
- G Ethernet switch
- H LTMTCUF control operator unit

Functional Characteristics

The TeSys Tera system manages:

- Single-phase or three-phase AC induction motors up to 100 A.
- Single-phase or three-phase AC induction motors up to 810 A when using external current transformers.
- The connection between the control system and the motor feeder, increases plant availability.

- Significant savings to the installation, commissioning, operation, and maintenance.
- Numerical microprocessor equipped controller that allows to set parameters of the motor according to the application and process requirements.

Key Benefits

The key benefits with use of advanced motor protection are:

- The TeSys Tera system covers all the load to monitor and protect the needs from the feeders to the critical process automation.
- The equipment is protected when advanced diagnostics, statistics, and alarms helps to anticipate unexpected production halts and minimize downtime.
- The TeSys Tera system is compact and a natural fit for the control panels with IEC or NEMA standards.
- The TeSys Tera system connectivity and access to real-time data provide key information to enhance the operation and security of the process while improving efficiency.

Features

The TeSys Tera system provides the following features:

- Configurable overload protection for class 5 to 40 based on current.
- Thermistor based motor protection.
- Imbalance, phase loss protection for current, and voltage input separately.
- Locked rotor and stall rotor protection.
- Electrical parameter monitoring, such as current, voltage, power, power factor, frequency, harmonics, temperature, and energy.
- Monitoring for different motor based parameters, such as operating hours, number of starts, run hours, and so on.
- TeSys Tera system can be used for motor and heater load application.
- Communication with PLC or DCS over EtherNet/IP, Modbus TCP/IP, Modbus RTU, or PROFIBUS DP protocol.
- Records trip data, event, self-diagnostic events with time stamp.
- Different starter configurations, such as overload, direct online (DOL), reverse direct online (RDOL), and star-delta.
- Independent protection, even if PLC or DCS connection is interrupted, TeSys Tera system still provides protection for the motor.
- Flexible protection, control, and communication options to suit any low voltage contactor-controlled motor starter application.
- Integrated push button and LED indicators reduce external components and wiring.
- Multiple communication protocols allow affordable integration to larger and complex substation monitoring and control systems.
- Reset push button is available on the LTMT main unit and the LTMTCUF control operator unit thereby reducing the need for one digital input to be configured as reset.
- Optional graphical LTMTCUF control operator unit is provided with the LTMT main unit for display of all metering, protection, and related parameters.
- Conformal coating (100-150 microns) on the PCB inside the LTMT main unit resists the corrosive environment, hazardous chemicals, dust, and so on.

Supported Industries

The TeSys Tera system supports the following industries and associated business sectors:

Industry	Sectors	Application
Industry	<ul style="list-style-type: none"> • Metal, mineral, and mining: cement, glass, steel, paper, gold, diamond, platinum • Petrochemical • Chemical: pulp and paper industry • Pharmaceutical • Oil and gas 	<ul style="list-style-type: none"> • Control and monitor pump motors • Control ventilation • Control load traction and movements • View status and communicate with machines • Process and communicate the data captured • Remotely manage data for one or several sites through the internet
Energy and Infrastructure	<ul style="list-style-type: none"> • Water treatment and transportation • Power generation and transport 	<ul style="list-style-type: none"> • Control and monitor pump motors • Control ventilation • Remotely control wind turbine • Remotely manage data for one or several sites through the Internet
Motor Control Centre (MCC)	<ul style="list-style-type: none"> • Process industry • Power plant engineering 	Protection and control of motors: <ul style="list-style-type: none"> • Heavy starting motors (paper, cement and metal industries, and water managements) • High availability plants (chemical, oil, raw material, processing industry, and power plants)

Technical Characteristics

Environmental Characteristics

Conforming to standards	IEC/EN 60947-4-1	
	UL/CSA 60947-4-1	
Product certifications	IEC, UL ⁽¹⁾	
Rated insulation voltage (Ui)	Conforming to IEC/EN 60947-1, overvoltage category III, degree of pollution 3	690 V
Rated impulse withstand voltage (Uimp)	Conforming to IEC/EN 60947-4-1	
	100–240 Vac/Vdc supply, digital inputs and digital outputs	4 kV
	24 Vdc supply, inputs and outputs	0.8 kV
	Communication circuits	0.8 kV
	Current or voltage measurement circuit	6 kV
Short-circuit withstand	Conforming to IEC/EN 60947-4-1	100 kA
Climatic withstand	Conforming to IEC/EN 60068-2-30	12 x 24 hour cycles
	Conforming to IEC/EN 60070-2-11	48 h
Corrosion immunity	Atmosphere free from corrosive gases	
Humidity	5–95%, non-condensing	
Ambient air temperature around the device	Storage	-40 to +80 °C (-40 to +176 °F)
	Operation	-20 to +70 °C (-4 to +158 °F)
Measured creepage distances	-	<ul style="list-style-type: none"> • 5.10 mm (0.20 in.) on 250 V • 7.25 mm (0.28 in.) on 690 V
Flame resistance	Conforming to UL 94	960 °C (1760 °F) (for parts supporting live components)
	Conforming to IEC/EN 60695-2-12	650 °C (1202 °F) (for other parts)
Shock resistance (1/2 sine wave, 11 ms)	Conforming to IEC/EN 60068-2-27 ⁽²⁾	15 gn
Vibration resistance	Conforming to IEC/EN 60068-2-6 ³	<ul style="list-style-type: none"> • 4 gn (plate mounted) • 1 gn (mounted on DIN rail)
	5–300 Hz	
Resistance to electrostatic discharge	Conforming to IEC/EN 61000-4-2	<ul style="list-style-type: none"> • In open air: 8 kV - Level 3 • On contact: 6 kV - Level 3
Immunity to radiated electromagnetic interference	Conforming to IEC 61000-4-3	10 V/m - Level 3
Immunity to fast transient	Conforming to IEC 61000-4-4	<ul style="list-style-type: none"> • On supply and digital outputs: 2 kV - Level 2 • Other circuits: 2kV - Level 1
Immunity to radioelectric fields ⁽³⁾	Conforming to IEC/EN 61000-4-6	10 V - Level 3

(1) This product has been designed for use in certified environment, else it may cause unwanted electromagnetic disturbance to self or other devices.

(2) Without modifying the contact states, in the most unfavorable direction.

(3) This product has been designed for use in environment A and in B, it may cause unwanted electromagnetic disturbance to other devices, which may require the implementation of adequate mitigation measures.

Immunity to Dissipated Shock Waves

Conforming to IEC/EN 61000-4-5		
	Common mode	Differential mode
Digital outputs and supply	2 kV	1 kV
24 Vdc digital inputs	2 kV	1 kV
100–240 Vac/Vdc digital inputs	2 kV	1 kV
Voltage inputs	2 kV	1 kV
Communication	2 kV	–
Temperature sensor (IT1/IT2)	–	1 kV

Altitude Derating

	2000 m (6562 ft)	3000 m (9843 ft)	3500 m (11483 ft)	4000 m (13123 ft)	4500 m (14764 ft)
Rated operational voltage (Ue)	1	0.93	0.87	0.8	0.7
Maximum operating temperature	1	0.93	0.92	0.9	0.88

Following are the details of derating based on altitude:

- Up to 2000 m, there is no impact on the rated operating voltage or the maximum operating temperature.
- Above 2000 m altitude, the derating begins and the percentage of derating is shown in the table above.

For example, if the product is installed between 2000 and 3000 m, the derating factor is 0.93, which means the values are 93% of the rated specifications. In this case, the rated operating voltage (Ue) changes from 100–265 V ac/dc to 100–246 V ac/dc, and the maximum operating temperature decreases from 70°C to 65°C.

Components of TeSys Tera System

The hardware components of the TeSys Tera system are:

- LTMT main unit
- LTMTCT/LTMTCTV sensor module
- LTMT expansion module
- LTMTCUF control operator unit

The microprocessor based LTMT main unit is the central component in the system that manages the control, protection, and monitoring functions of three-phase and single-phase AC induction motors.

The LTMT main unit is designed to work with the following protocols:

- Modbus RTU
- PROFIBUS DP
- EtherNet/IP or Modbus TCP/IP

The system can be configured and controlled by using following interfaces:

- A PC running the TeSys Tera DTM embedded in a FDT container such as SoMove software.
- The LTMTCUF control operator unit
- A PLC or DCS connected to the system through the communication network.

LTMT Main Unit

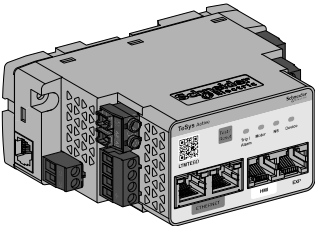
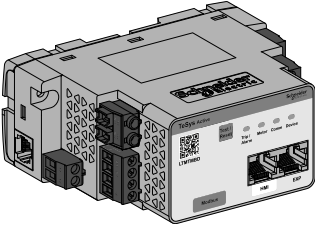
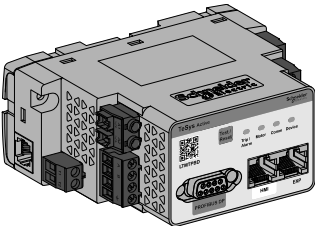
LTMT main unit	Features	Communication	Reference
<p>EtherNet/IP or Modbus TCP/IP</p> 	<ul style="list-style-type: none"> • Current and voltage based protections • Motor monitoring and metering functions • Four non-isolated digital inputs • Three digital outputs: <ul style="list-style-type: none"> ◦ 2 outputs with NO contacts ◦ 1 output with NO+NC contacts • Records <ul style="list-style-type: none"> ◦ Trip records ◦ Event records ◦ Device internal records 	<p>EtherNet/IP or Modbus TCP/IP</p> <ul style="list-style-type: none"> • Network management protocols such as Dynamic Host Configuration Protocol (DHCP) • Webserver for Ethernet settings modification and monitoring of electrical parameter or status 	<ul style="list-style-type: none"> • LTMTEFM (100–240 Vac/Vdc) • LTMTEBD (24 Vdc)
<p>Modbus RTU</p> 	<ul style="list-style-type: none"> • Current and voltage based protections • Motor monitoring and metering functions • Four non-isolated digital inputs 	<p>Modbus RTU</p> <ul style="list-style-type: none"> • Baud rate: 2400–115200 bit/s • Read or Write function code 	<ul style="list-style-type: none"> • LTMTMFM (100–240 Vac/Vdc) • LTMTMBD (24 Vdc)
<p>PROFIBUS DP</p> 	<ul style="list-style-type: none"> • Three digital outputs: <ul style="list-style-type: none"> ◦ 2 outputs with NO contacts ◦ 1 output with NO+NC contacts • Records <ul style="list-style-type: none"> ◦ Trip records ◦ Event records ◦ Device internal records 	<p>PROFIBUS DP</p> <ul style="list-style-type: none"> • DP-V0 cyclic services • DP-V1 acyclic services • Time synchronisation • Automatic baud rate detection • 12 Mbit/s on D-Type connector and 1.5 Mbit/s on terminal connector 	<ul style="list-style-type: none"> • LTMTPFM (100–240 Vac/Vdc) • LTMTPBD (24 Vdc)

LTMTCT/LTMTCTV Horizontal Sensor Module

The following table introduces the key features of the LTMTCT/LTMTCTV sensor modules for horizontal mounting:

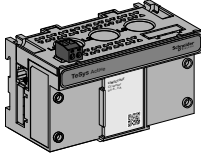
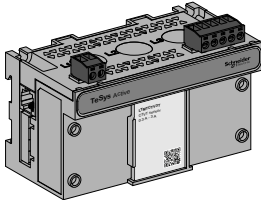
Sensor module	Features	Current range	Voltage range	Reference
LTMTCT modules with current transformers 	<ul style="list-style-type: none"> Phase current measurement Phase current imbalance calculation Ground current calculation Ground current measurement with external ground current transformer Phase loss and phase reversal detection based on current 	0.3–3 A	-	LTMTCT3T
		2.5–25 A	-	LTMTCT25T
		10–100 A	-	LTMTCT100T
LTMTCTV modules with current and voltage transformers 	<ul style="list-style-type: none"> Phase current and voltage measurement Phase current and voltage imbalance calculation Ground current calculation Ground current measurement with external ground current transformer Phase loss and phase reversal detection based on current and voltage Frequency measurement Power, energy, and power factor calculation 	0.3–3 A	60–690 Vac	LTMTCTV3T
		2.5–25 A	60–690 Vac	LTMTCTV25T
		10–100 A	60–690 Vac	LTMTCTV100T

LTMTCTV Horizontal Sensor Module for Side Connector Applications

The following table introduces the key features of LTMTCTV horizontal sensor module for side connector applications:

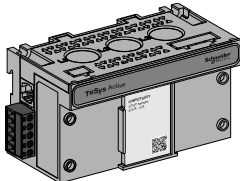
Sensor module	Features	Current range	Voltage range	Reference
LTMTCTV modules with current and voltage transformers, equipped with side connectors. 	<ul style="list-style-type: none"> Phase current and voltage measurement Phase current and voltage imbalance calculation Ground current calculation Ground current measurement with external ground current transformer Phase loss and phase reversal detection based on current and voltage Frequency measurement Power, energy, and power factor calculation Suitable for UL and NEMA connector applications 	0.3–3 A	60–600 Vac	LTMTCTV3UT
		2.5–25 A	60–600 Vac	LTMTCTV25UT
		10–100 A	60–600 Vac	LTMTCTV100UT

LTMT Expansion Module

The following table introduces the key features of the LTMT expansion module. The maximum number of each LTMT expansion module that can be connected to one LTMT main unit is also provided in the table.

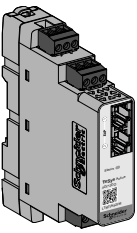
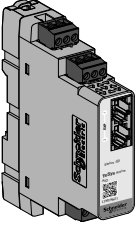
LTMT expansion module	Features	Reference	Maximum number
<p>4 Digital Inputs and 2 Digital Outputs</p> 	<ul style="list-style-type: none"> • Four isolated digital inputs (DI) • Two digital outputs (DO) with NO contacts • Status LED indication • Powered by LTMT main unit 	<ul style="list-style-type: none"> • LTMTIN42FM (DI rating: 100–265 Vac/dc for IEC, 110–240 Vac/dc for UL) • LTMTIN42BD (DI rating: 24 Vdc) 	5
<p>2 Analog Inputs and 1 Analog Output</p> 	<ul style="list-style-type: none"> • 4–20 mA measurement • Two analog inputs • One analog output • Status LED indication • Powered from LTMT main unit 	LTMTAN21	2

LTMTCUF Control Operator Unit

The LTMTCUF control operator unit is the local Human Machine Interface (HMI) of the TeSys Tera system.

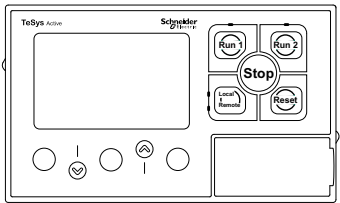
LTMTCUF control operator unit	Features	Reference
	<ul style="list-style-type: none"> • Powered by LTMT main unit • Liquid Crystal Display (LCD) • Contextual navigation keys • Displays parameters, alarms, and trips • Controls the motor • Fast Device Replacement (FDR) service 	LTMTCUF

TeSys Tera DTM

TeSys Tera Device Type Manager (DTM) is a software module hosted in a Field Device Tool (FDT) container that uses the open FDT/DTM technology. For example, SoMove software.

In SoMove software, a specific DTM exists for the TeSys Tera system. The TeSys Tera DTM Library must be installed after installing the SoMove software.

TeSys Tera DTM	Features	Reference
	<ul style="list-style-type: none"> • Compatible with SoMove software and other FDT containers. • Configures the system through menu entries. • Displays parameters, alarms, and trips. • Option for controlling the motor feeder. • Enable customization of operating modes. 	<ul style="list-style-type: none"> • TeSys Tera DTM v2.0.0 • SoMove software (v2.9.9 or later) FDT container

SoMove Software

SoMove software is a Microsoft Windows® based application, using the open FDT/DTM technology.

SoMove software contains DTM for different devices. The TeSys Tera DTM is a specific DTM that enables the configuration, monitoring, control, and customization of the control functions of the TeSys Tera system.

Cables

The components of the system require cables to connect to other components and to the communication network.

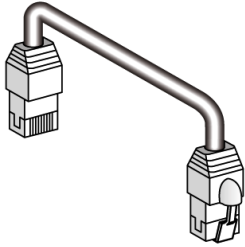
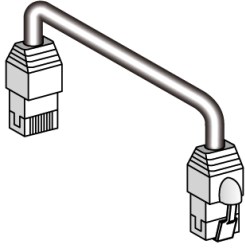
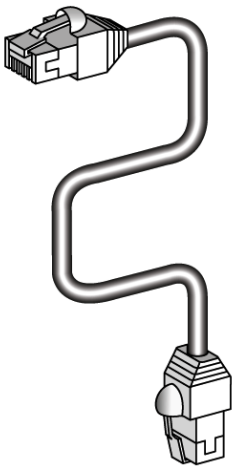
Connect to	Cable	Description	Reference
LTMTCT/LTMTCTV sensor module		LTMT main unit to LTMTCT/LTMTCTV sensor module RJ11 connector cable 0.15 m (5.9 in) in length.	LTMT9RJ1015
		LTMT main unit to LTMTCT/LTMTCTV sensor module RJ11 connector cable 0.5 m (19.6 in) in length.	LTMT9RJ105
		LTMT main unit to LTMTCT/LTMTCTV sensor module RJ11 connector cable 0.2 m (7.87 in) in length	LTMT9RJ102
LTMT expansion module		LTMT main unit to LTMT expansion module RJ45 connector cable 0.1 m (3.9 in) in length.	LTMT9RJ401
		LTMT main unit to LTMT expansion module RJ45 connector cable 1 m (39.37 in) in length	LTMT9EX10
LTMTCUF control operator unit		LTMT main unit to LTMTCUF control operator unit connection cable 1.0 m (39.3 in) in length.	LTMT9CU10S
		LTMT main unit to LTMTCUF control operator unit connection cable 3.0 m (118.1 in) in length.	LTMT9CU30S

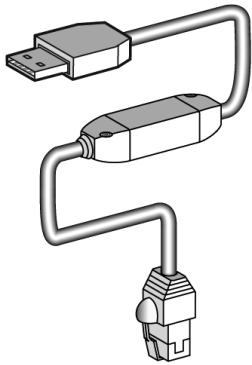
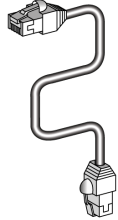
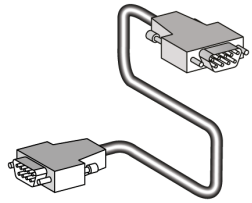
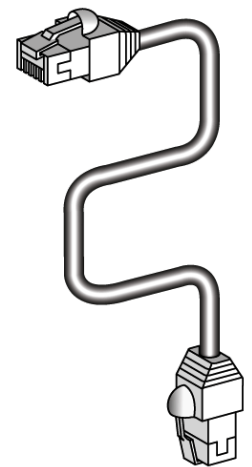
Connect to	Cable	Description	Reference
PC		PC to LTMT main unit or LTMTCUF control operator unit cable 2.5 m (98.4 in) in length.	TCSMCNAM3M002-P
Modbus RTU network		Modbus RTU network communication cable 0.3 m (11.81 in.) in length.	-
		Modbus RTU network communication cable 1.0 m (39.3 in) in length.	-
		Modbus RTU network communication cable 3.0 m (118.1 in) in length.	-
PROFIBUS DP network		PROFIBUS DP network communication cable 100 m (328.08 ft) in length.	TSXPBSCA100
		PROFIBUS DP network communication cable 400 m (1,312.33 ft) in length.	TSXPBSCA400
EtherNet/IP or Modbus TCP/IP network		Shielded category five straight-through twisted-pair cable of length 2 m (6.5 ft) in length with two RJ45 connectors.	490NTW00002

Load Current Transformers

External load current transformers expand the current range for use with motors greater than 100 A at full load.

Schneider Electric load current transformers	Primary	Secondary	Inside diameter		Reference
			mm	In.	
	100	1	35	1.38	LT6CT1001
	200	1	35	1.38	LT6CT2001
	400	1	35	1.38	LT6CT4001
	800	1	35	1.38	LT6CT8001

NOTE:

- The LTMTCT3/LTMTCTV3 sensor module accepts 1 A and 5 A secondary signals from external current transformers.
- The LTMTCT25/LTMTCTV25 sensor module accepts 5 A secondary signals from external current transformers.
- 3 A and 25 A CT to be used for external CT.

For more information on external CT wiring, refer to *TeSys Tera Motor Management System Installation Guide – DOCA0356EN*.

Ground Current Transformers

External ground current sensors measure ground current trip conditions.

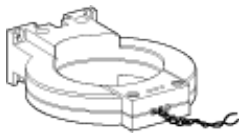
Schneider Electric VigiPacT ground current transformers	Type	Maximum current	Inside diameter		Transformation ratio	Reference
			mm	In.		
	TA30	65 A	30	1.18	1000:1	50437
	PA50	85 A	50	1.97		50438
	IA80	160 A	80	3.15		50439
	MA120	250 A	120	4.72		50440
	SA200	400 A	200	7.87		50441
	PA300	630 A	300	11.81		50442

Description of TeSys Tera Motor Management System

What's in This Chapter

LTMT Main Unit.....	32
Communication Ports	37
LTMTCT/LTMTCTV Sensor Module	39
LTMT Expansion Module	40
LTMTCUF Control Operator Unit	43

LTMT Main Unit

The LTMT main unit is the main module of the TeSys Tera system which coordinates with different modules to provide features like protection, control, monitor, data storage, communication, and so on.

The LTMT main unit is available with following communication protocols:

- Modbus RTU
- PROFIBUS DP
- EtherNet/IP and Modbus TCP/IP

The advantages of the LTMT main unit are:

- The LTMT main unit provides power to the LTMTCT/LTMTCTV sensor module and LTMT expansion modules.
- The LTMT main unit is independent of LTMTCT/LTMTCTV sensor module type. The LTMT main unit can be used for current-based protection or current and voltage-based protections.
- The LTMT main unit can be mounted on top of the LTMTCT/LTMTCTV sensor module, which reduces width of basic module.

Except communication interface field bus, all the LTMT main unit connections remain same in all variants.

For more information on TeSys Tera system installation, refer to *TeSys Tera Motor Management System Installation Guide – DOCA0356EN*.

Front Face Description

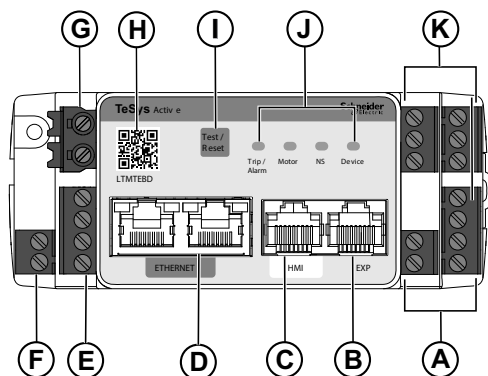

- A Digital input connectors
- B RJ45 for LTMT expansion module connection
- C RJ45 for HMI and PC connection
- D RJ45 ports for EtherNet/IP and Modbus TCP/IP communication
- E Device shield ground terminals
- F Temperature input connector
- G Power supply connector
- H QR code to product information page
- I Trip/Reset button
- J Status LED
- K Digital output connectors

Status LED

LED name	LED Color Indication	Description
Device	Off	Power Off
	Green on	LTMT main unit is in healthy condition (turned on after power on self-test)
	Green blinking	<ul style="list-style-type: none"> LTMT main unit is in logic test mode Firmware upgrade check and firmware upgrade in progress
	Red on	Internal error detected or configuration error detected
	Red blinking	Communication between LTMT main unit and LTMTCT/LTMTCTV sensor module or LTMT expansion modules is lost. Fallback (LTMT** and LTMTM**)
Motor	Off	Motor in Inhibit state
	Green on	Motor in Stop state, ready to Start
	Green blinking	Motor is running
Trip/Alarm	Off	No trip or alarm condition
	Blue blinking	Alarm condition is present
	Blue on	Pickup condition is present
	Red blinking	LTMT main unit has tripped and trip condition is still present. Trip cannot be reset.
	Red on	LTMT main unit has tripped and trip condition is not present. Trip can be reset.
NS ⁽⁴⁾	Off	Not powered or no IP address
	Steady green on	Configured client is connected and IO connection is established or device is in Fallback IP
	Green flashing ⁽⁵⁾	IP address is configured but no IO connections are established
	Red flashing ⁽⁶⁾	Communication loss or connection time out
	Flashing green or red once ⁽⁶⁾	During device power up self-test is performed
LK ⁽⁷⁾	Off	No connection established
	Yellow steady	Link
	Yellow blinking	Activity
ACT ⁽⁷⁾	Off	10 Mbps speed
	Green steady	100 Mbps speed
Comm ⁽⁸⁾	Off	Communication is not established with PLC or DCS
	Green on	Communication is established with PLC or DCS
	Red blinking	Communication is lost with PLC or DCS

⁽⁴⁾ LED is available only with EtherNet/IP and Modbus TCP/IP protocol

⁽⁵⁾ Flash time 0.5 s off and 0.5 s on

⁽⁶⁾ Flash time 0.5 s Off and 0.5 s on

⁽⁷⁾ LED is available only with EtherNet/IP and Modbus TCP/IP protocol

⁽⁸⁾ LED is available only with Modbus RTU and PROFIBUS DP protocol

Trip/Reset Button

Use the **Trip/Reset** button to perform the following functions:

Function	Description	Procedure
Trip reset	Resets all trips that can be reset.	Press the button and release it within 3 s.
Self test	Performs a self test if: <ul style="list-style-type: none"> No trips exist Test mode function is enabled. 	Press and hold the button for more than 3 s not exceeding 15 s.
Return to default values	Returns the LTMT main unit parameters to default values if the motor is in Stop state. If the motor is in Start or Run state, the return to default values is ignored.	Press and hold the button for more than 15 s not exceeding 20 s. When the button is pressed for more than 15 s, the Trip/Alarm LED blinks in blue color. The LTMT main unit parameters are reset to their default values when the button is released.
Induce a trip	Put the LTMT main unit into internal stucked reset key trip.	Press and hold the button for more than 20 s. The LTMT main unit trips and trip is recorded in the Trips log.

Digital Inputs

The LTMT main unit has four potential free digital inputs (type 1 according to EN61131-2 standard).

The digital inputs can be powered internally through the LTMT main unit.

When the digital inputs are powered internally, the four digital inputs I.1, I.2, I.3, and I.4 can be used.

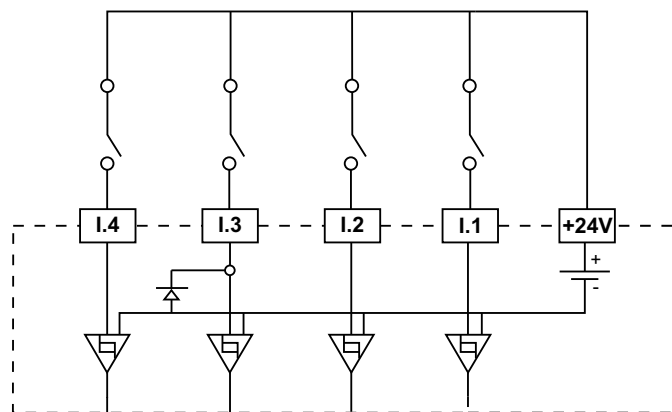

Digital Outputs

⚠ WARNING

UNINTENDED EQUIPMENT OPERATION

When motor is running with starter:

- Under nominal condition: Digital output of LTMT main unit and LTMT expansion module will remain in NC state and follows the DO input source.
- Under degraded condition: If LTMT main unit and LTMT expansion module cable is disconnected, the digital output of LTMT main unit will be in NO state, and the digital output of LTMT expansion module will continue in NC state.

Failure to follow these instructions can result in death, serious injury, or equipment damage.

The LTMT main unit has three digital outputs:

- Two outputs with NO contacts
- One output with NO+NC contacts

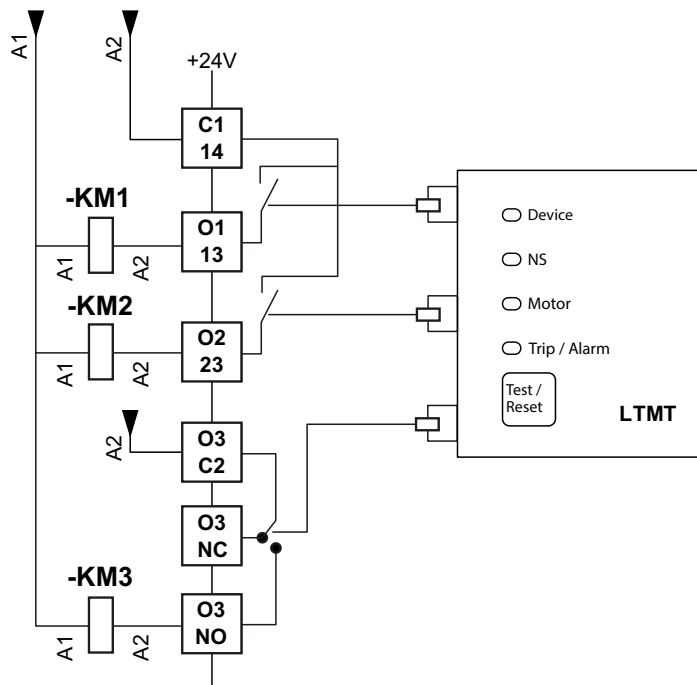

LTMT Main Unit Temperature

A 2-wire PT100 or PTC temperature sensor can be connected to the LTMT main unit.

Expansion Port

The expansion port is used to connect optional LTMT expansion modules with the LTMT main unit. All LTMT expansion modules are connected in daisy chain.

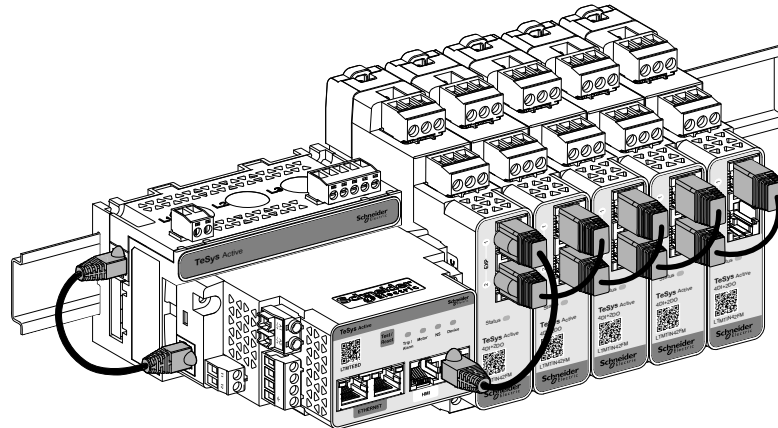

LTMT HMI Port

The LTMT HMI port is used to connect the optional LTMT CUF control operator unit with the LTMT main unit. For more information on cables, refer [Cables](#), page 27 section.

The pinout of the shielded RJ45 connector of the LTMT HMI port is as follows:

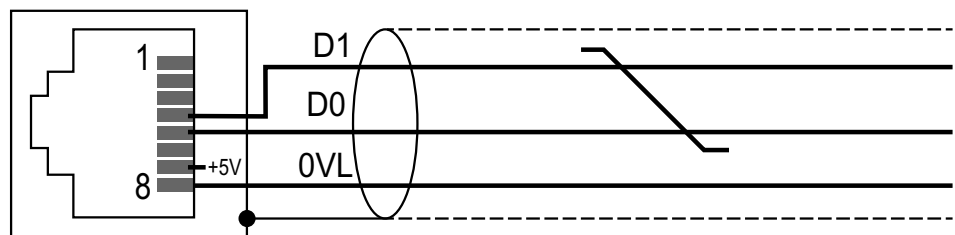

Pin No.	Signal	Description
1	–	Not connected
2	–	Not connected
3	–	Not connected
4	D1 or D(B)	Transceiver terminal 1
5	D0 or D(A)	Transceiver terminal 0
6	–	Not connected
7	+5V	Auxiliary supply to LTMT CUF control operator unit
8	0VL	Signal and power supply common

Communication Ports

The LTMT main unit has the following kinds of communication ports:

- EtherNet/IP communication port
- Modbus RTU communication port
- PROFIBUS DP communication port

Ethernet Communication Port

NOTICE
UNAUTHORIZED ETHERNET PORT USAGE
Use only one Ethernet communication port at a time, even though both ports are functionally identical.
Failure to follow these instructions can result in equipment damage.

The LTMT main unit with EtherNet/IP or Modbus TCP/IP communication protocols is equipped with two RJ45 Ethernet communication ports on the front face. They follow the Ethernet interoperability standards. It allows star and point-to-point connections. The main physical characteristics of Ethernet ports are:

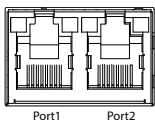
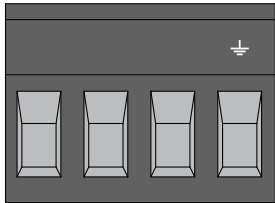
Image	Connector	Description
	RJ45 connector	<ul style="list-style-type: none"> • Port 1 • Port 2
	⏏	Shielded ground terminal

For more information on wiring and connections, refer *TeSys Tera Motor Management System EtherNet/IP Communication Guide - DOCA0258EN*

Modbus RTU Communication Port

The LTMT main unit with Modbus RTU communication is connected to the Modbus field terminals by using a 4-terminal connector.

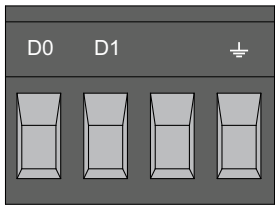
Image	Terminals	Description
	D0	Data -
	D1	Data +
	⏏	Shielded earth

For more information on wiring and connections, refer to *TeSys Tera Motor Management System Modbus RTU Communication Guide – DOCA0355EN*.

PROFIBUS DP Communication Port

The LTMT main unit with PROFIBUS DP communication can be connected in the PROFIBUS DP daisy chain using two different connectors. In the LTMT main unit, standard DB9 connector is used for conventional method for PROFIBUS DP network. It can be achieved, by looping terminal available for PROFIBUS DP connection.

The maximum data speed with the different connectors are mentioned below.

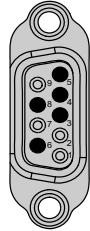
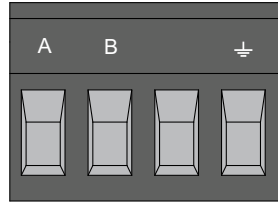
Image	Connector	Data speed
	D-type connector	12 Mbits/s
	Terminal connector	1.5 Mbits/s

The PROFIBUS DP 4-terminal connector has the following pin assignments:

Terminal	Signal	Description
A	RD-/TD-	Negative data transmission (RD-/ RD-)
B	RD+/TD+	Positive data transmission (RD+/ RD+)
	-	Shielded earth

For more information on wiring and connections, refer to *TeSys Tera Motor Management System PROFIBUS DP Communication Guide – DOCA0256EN*.

LTMTCT/LTMTCTV Sensor Module

The LTMTCT/LTMTCTV sensor module measures the electrical parameters of a motor:

- LTMTCT sensor module measures the motor currents.
- LTMTCTV sensor module measures the motor currents and voltages.

LTMTCT/LTMTCTVT Horizontal Sensor Module

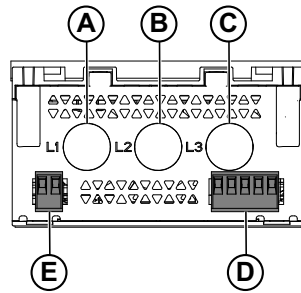

- A Window for phase 1 current measurement
- B Window for phase 2 current measurement
- C Window for phase 3 current measurement
- D Phase voltage input connector (on LTMTCTV modules only)
- E Ground current measurement input connector

LTMTCTV Horizontal Sensor Module for SIDE Connector Applications

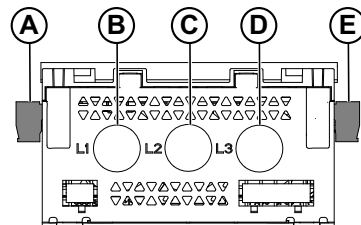

- A Phase voltage input connector
- B Window for phase 1 current measurement
- C Window for phase 2 current measurement
- D Window for phase 3 current measurement
- E Ground current measurement input connector

LTMT Expansion Module

A maximum of five LTMT expansion module can be connected to one LTMT main unit. For more information on LTMT expansion module refer to LTMT Expansion Module, page 24.

Front Face Description

The LTMT expansion module front face includes the following features:

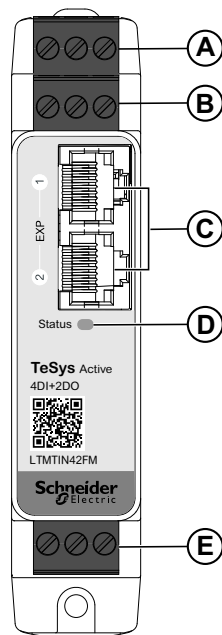

- A Input connector 1
- B Input connector 2
- C Two RJ45 for connection of the module to the main unit or other LTMT expansion modules
- D Status LED
- E Output connector 3

Status LED

LED status	Description
Off	Power off
GREEN on	LTMT expansion module is ready and communicating with LTMT main unit
RED blinking	<ul style="list-style-type: none"> • Communication with LTMT main unit is not established • Firmware update is in progress
RED on	Internal error detected or configuration error detected

Expansion Ports

Each LTMT expansion module has two RJ45 for connection with the LTMT main unit in daisy chain.

For more information on wiring and connections, refer to *TeSys Tera Motor Management System Installation Guide – DOCA0356EN*.

4 Digital Inputs and 2 Digital Outputs LTMT Expansion Module

The LTMTIN42** expansion modules have:

- Four digital inputs (Type 1 according to standard EN61131-2).
- Two potential free digital outputs with Normally open contacts.

The digital inputs are powered by an external power supply. The input supply voltage for the LTMTIN42BD expansion module is 24 Vdc and for the LTMTIN42FM expansion module is 100–265 Vac/dc for IEC, 110–240 Vac/dc for UL.

The LTMTIN42** expansion modules have the following plug-in terminals and pin assignments:

Connector	Terminal	Description
1	I.5	Digital input 5
	I.C	Common for digital inputs
	I.6	Digital input 6
2	I.7	Digital input 7
	-	No connection
	I.8	Digital input 8
3	C1	Common for digital output
	34	
	O2	Digital output 2
	35	
	O1	
33		

2 Analog Inputs and 1 Analog Output LTMT Expansion Module

The LTMTAN21 expansion modules have:

- Two analog inputs 4–20 mA
- One analog output 4–20 mA

The LTMTAN21 expansion modules have the following plug-in terminals and pin assignments:

Connector	Terminal	Description
1	I1+	Analog input 1 (+) terminal
		No connection
	I1–	Analog input 1 (-) terminal
2	I2+	Analog Input 2 (+) terminal
		No connection
	I2–	Analog input 2 (-) terminal
3	O+	Analog output (+) terminal
		No connection
	O–	Analog output (-) terminal

LTMTCUF Control Operator Unit

The LTMTCUF control operator unit is a Human Machine Interface (HMI) that enables the configuration, monitoring, and control of the LTMT main unit, as part of the TeSys Tera Motor Management System

For information on installing the LTMTCUF control operator unit, refer to *TeSys Tera Motor Management System Installation Guide – DOCA0356EN*.

For information on using the LTMTCUF control operator unit, refer to *TeSys Tera Motor Management System LTMTCUF Control Operator Unit User Guide – DOCA0233EN*.

Front Face Description

The LTMTCUF control operator unit front face includes the following features:

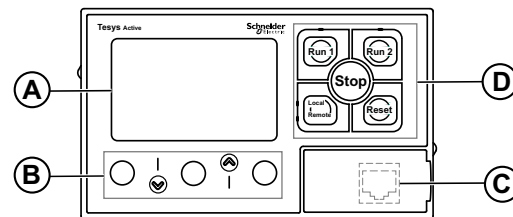

- A LCD display
- B Contextual navigation keys
- C Front face RJ45 for PC connection (covered)
- D Local control interface, including five control keys and four LED

Rear Face Description

The LTMTCUF control operator unit rear face is shown in the following diagram:

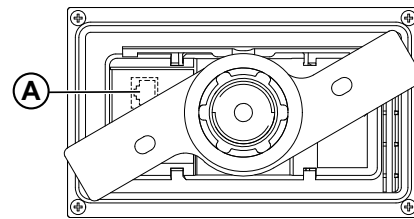

- A Rear face RJ45

Status LED

In the diagram below, the four control LED are labeled A – D:

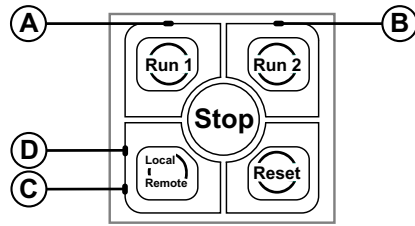

The following table describes each of the four LEDs:

LED	Status	Description
A	Motor ON/OFF status	CONTACTOR OUTPUT 1 is active
B		CONTACTOR OUTPUT 2 is active
C	Active mode status	The active control source is the Remote source
D		The active control source is the Local source (Local1, Local2, and Local3)

For more information, refer to *TeSys Tera Motor Management System LTMTCUF Control Operator Unit User Guide – DOCA0233EN*.

Control Keys

The local control interface consists of five control keys.

Key	Description
Run 1	Motor control keys
Run 2	
Stop	
Local/Remote	Active control source selection
Trip/Reset	Trip reset

For more information, refer to *TeSys Tera Motor Management System LTMTCUF Control Operator Unit User Guide – DOCA0233EN*.

Settings of TeSys Tera Motor Management System

What's in This Chapter

Name Plate.....	46
Device Configuration	48
System Settings	50

Name Plate

⚠ WARNING
<p>UNINTENDED EQUIPMENT OPERATION</p> <p>The application of this product requires expertise in the design and programming of control systems. Only personnel with such expertise should be allowed to program, install, configure, alter and apply this product. Follow all local and national safety codes and standards.</p> <p>Failure to follow these instructions can result in death, serious injury, or equipment damage.</p>

The system settings can be set up using following interfaces:

- A PC running the TeSys Tera DTM embedded in a FDT container such as SoMove software.
- The LTMTCUF control operator unit
- A PLC or DCS through the communication network.

Parameter name	Setting range	Default value
Tag ⁽⁹⁾	MMR0000001	MMR0000001
Nominal Power	0.1–6553.5 KW	0.1 KW
Load Type	<ul style="list-style-type: none"> • Motor • Heater 	Motor
Number of Phases	<ul style="list-style-type: none"> • Three Phase • Single Phase 	Three Phase

Nominal Power

Nominal power value entered in name plate menu is reference for all power related protection.

NOTE: Full load current value is either IFLC based on the starter type selection and speed selected through motor commands.

Load Type

TeSys Tera system supports Motor (inductive) and Heater (resistive) as load types. You can configure the load type base on the load.

The default load type is Motor, that enables full functionality of TeSys Tera system based on the device configuration.

The following protection functions are disabled in Heater load type:

- Thermal Overload
- Locked Rotor
- Stall Rotor
- Maximum Number of Starts
- Anti-Backspin Timer
- Voltage Dip
- Block Output

⁽⁹⁾ Tag parameter is not available in EtherNet/IP and Modbus TCP/IP protocol.

Direct Online starter can be used to control Heater Start or Stop in Heater load type.

Number of Phases

Select **Three-Phase** setting for three-phase motor, and **Single-Phase** setting for single phase motor.

Device Configuration

⚠ WARNING

UNINTENDED EQUIPMENT OPERATION

- The application of this product requires expertise in the design and programming of control systems. Only personnel with such expertise should be allowed to program, install, configure, alter and apply this product. Follow all local and national safety codes and standards.
- Change in Device Configuration can cause short circuit or turn on power supply to the load.
- Check if appropriate wiring is done according to the Device Configuration.
- Ensure that the three-phase or single-phase power supply is cut off to the motor, and control supply to the inputs and outputs is cut off to the LTMT expansion modules while changing the Device Configuration.

Failure to follow these instructions can result in death, serious injury, or equipment damage.

The configuration of the TeSys Tera system can be set up using following interfaces:

- PC running SoMove FDT container software with TeSys Tera DTM installed.
- The LTMTCUF control operator unit.
- A PLC or DCS through the communication network.

Parameter Setting

Parameter name	Setting range	Default value
LTMT main unit	<ul style="list-style-type: none"> • LTMTEBD • LTMTEFM • LTMT PBD • LTMT PFM • LTMTMBD • LTMTMFM 	None
LTMTCT/LTMTCTV sensor module type	<ul style="list-style-type: none"> • LTMTCT3T • LTMTCTV3T • LTMTCT25T • LTMTCTV25T • LTMTCT100T • LTMTCTV100T • LTMTCTV3UT • LTMTCTV25UT • LTMTCTV100UT 	None
LTMT expansion module 1 type	<ul style="list-style-type: none"> • None • LTMTIN42FM • LTMTIN42BD • LTMTAN21 	None
LTMT expansion module 2 type	<ul style="list-style-type: none"> • None • LTMTIN42FM • LTMTIN42BD • LTMTAN21 	None
LTMT expansion module 3 type	<ul style="list-style-type: none"> • None • LTMTIN42FM 	None

Parameter name	Setting range	Default value
	<ul style="list-style-type: none">• LTMTIN42BD• LTMTAN21	
LTMT expansion module 4 type	<ul style="list-style-type: none">• None• LTMTIN42FM• LTMTIN42BD• LTMTAN21	None
LTMT expansion module 5 type	<ul style="list-style-type: none">• None• LTMTIN42FM• LTMTIN42BD• LTMTAN21	None
LTMT main unit temperature	<ul style="list-style-type: none">• None• PT100• PTC	None

System Settings

⚠ WARNING

UNINTENDED EQUIPMENT OPERATION

- The application of this product requires expertise in the design and programming of control systems. Only personnel with such expertise should be allowed to program, install, configure, alter and apply this product. Follow all local and national safety codes and standards.
- Make sure FLC is to be maintained at same as FLC motor rating.

Failure to follow these instructions can result in death, serious injury, or equipment damage.

The system settings can be set up using following interfaces:

- A PC running the TeSys Tera DTM embedded in a FDT container such as SoMove software.
- The LTMTCUF control operator unit
- A PLC or DCS through the communication network.

Parameter Setting

Parameter name	Setting range	Default value
Phase CT Primary	1–1000 A in step of 1 A	1 A
Phase CT Secondary	1 A or 5 A	1 A
Voltage Nominal	110.0–690.0 V	415 V
Nominal Frequency	<ul style="list-style-type: none"> • 50 Hz • 60 Hz 	50 Hz
Phase Rotation	<ul style="list-style-type: none"> • L123 • L132 	L123
Voltage Input	<ul style="list-style-type: none"> • Disable • Enable 	Enable
Full Load Current (IFLC) ⁽¹⁰⁾	0.1–1000 A in step of 0.1 A	2.5 A
Phase CT Secondary Passes	1–10 in step of 1	1
Test Mode	<ul style="list-style-type: none"> • Disable • Enable 	Enable
Bypass interlocks During Test ⁽¹¹⁾	<ul style="list-style-type: none"> • No • Yes 	No

⁽¹⁰⁾ Default value for Full load current will change as per the CT sensor, external CT and number of turns.

⁽¹¹⁾ Interlock will be bypassed, when the Test Mode is enabled and also Logic Test DI is ON.

Full Load Current (IFLC)

Set the Full load current as per the motor current ratings. Many protection parameters are set as a multiple of the full load current (IFLC).

If the motor current is measured directly by the LTMTCT/LTMTCTV sensor module, the IFLC setting range is defined by the LTMTCT/LTMTCTV sensor module type.

Reference	Sensor module	IFLC setting range
LTMTCT3T	LTMTCT horizontal module	0.3–3 A
LTMTCTV3T	LTMTCTV horizontal module	0.3–3 A
LTMTCT25T	LTMTCT horizontal module	2.5–25 A
LTMTCTV25T	LTMTCTV horizontal module	2.5–25 A
LTMTCT100T	LTMTCT horizontal module	10–100 A
LTMTCTV100T	LTMTCTV horizontal module	10–100 A
LTMTCTV3UT	LTMTCTV horizontal module for UL applications	0.3–3 A
LTMTCTV25UT	LTMTCTV horizontal module for UL applications	2.5–25 A
LTMTCTV100UT	LTMTCTV horizontal module for UL applications	10–100 A

- If the motor current is measured by an external current transformer with Phase CT secondary or 1 A or 5 A and a LTMTCT3/LTMTCTV3 sensor module, the IFLC setting range is defined by:
 - $IFLC_{min} (A) = (\text{Phase CT primary} / \text{Phase CT secondary}) \times 0.3$
 - $IFLC_{max} (A)$:
 - For CT secondary 1 A = Phase CT primary X 2
 - For CT secondary 5 A = $(\text{Phase CT primary} / \text{Phase CT secondary}) \times 3$

For example:

Phase CT primary = 100 A

Phase CT secondary = 5 A

$IFLC_{min} (A) = (100 \text{ A} / 5 \text{ A}) \times 0.3 = 6 \text{ A}$

$IFLC_{max} (A) = (100 \text{ A} / 5 \text{ A}) \times 3 = 60 \text{ A}$

Phase CT primary = 100 A

Phase CT secondary = 1 A

$IFLC_{min} (A) = (100/1) \times 0.3 = 30 \text{ A}$

$IFLC_{max} (A) = (100 \text{ A}) \times 2 = 200 \text{ A}$

- If the motor current is measured by an external current transformer with CT secondary 5 A and a LTMTCT25/LTMTCTV25 sensor module, IFLC setting range is defined by:

- $IFLC_{min} (A) = \text{Phase CT primary} \times 0.5$

- $IFLC_{max} (A) = \text{Phase CT primary} \times 2$

For example:

Phase CT primary = 100 A

Phase CT secondary = 5 A

$IFLC_{min} (A) = (100 \text{ A}) \times 0.5 = 50 \text{ A}$

$IFLC_{max} (A) = (100 \text{ A}) \times 2 = 200 \text{ A}$

Phase CT

Set the Phase CT primary and Phase CT secondary parameters:

- To 1 if the motor current is measured directly by the LTMTCT/LTMTCTV sensor module.
- Or with the characteristics of the external current transformers used to measure the motor current.

Set always the Phase CT secondary passes to 1 (default value).

Voltage Nominal

The nominal voltage parameter is applicable only for LTMTCTV sensor modules.

For three-phase motor, set the nominal voltage (line to line voltage) as per the motor rating.

For single-phase motor, set the nominal voltage (line to neutral) as per the motor rating.

Voltage Input

The voltage input parameter is applicable only for LTMTCTV sensor modules.

If the voltage input parameter is disabled (default value), TeSys Tera system will not provide voltage protections and measurements.

Metering Functions

What's in This Part

- Overview 54
- Current Measurement..... 55
- Voltage Measurement..... 61
- Power and Energy Measurement..... 67
- THD Metering for Current and Voltage 72
- Temperature Measurement 73
- Analog Input Measurement 74

Overview

The LTMT main unit measures real-time values of current, voltage, power, analog inputs, temperature, and motor specific parameters.

The LTMT main unit uses these measurements to perform protection, control, monitoring, and logic functions. Each measurement is detailed in this section.

All parameter values are accessible from the LTMT main unit using following interfaces:

- A PC running the TeSys Tera DTM embedded in a FDT container such as SoMove software.
- The LTMTCUF control operator unit.
- A PLC or DCS through the communication network.

Current Measurement

What's in This Chapter

RMS Current.....	56
Ground Current.....	57
Average Current.....	58
Current Imbalance.....	59
Current Phase Sequence.....	60

RMS Current

Description

The LTMT main unit measures RMS values of line currents by using a LTMTCT/LTMTCTV sensor module.

- IL1: Phase 1 RMS current
- IL2: Phase 2 RMS current
- IL3: Phase 3 RMS current

Characteristics

Characteristic	Value
Unit	Ampere (A)
Resolution	0.001 A
Refresh interval	20 ms

Ground Current

Description

The ground current is an imbalanced current flowing through the neutral of the three-phase system. In normal conditions, the ground current is negligible or null. It is present only when a ground-trip occurs.

The ground current is:

- Calculated internally by the LTMCT/LTMCTV sensor module from the measured phase currents.
- Measured by an external ground current transformer connected either to the LTMCT••T/LTMCTV••T horizontal sensor module.

NOTE: Calculated ground current is not available in single-phase mode.

Calculated Ground Current

The ground current is calculated internally by the LTMCT/LTMCTV sensor modules and is equal to the vector sum of three-phase current values.

Characteristic	Value
Unit	Ampere (A)
Resolution	0.001 A
Refresh interval	100 ms

Measured Ground Current

The measured ground current is more accurate than the calculated ground current.

The ground current can be measured using an external ground current transformer, page 29.

Characteristic	Value
Unit	Ampere (A)
Resolution	0.001 A
Refresh interval	100 ms

NOTE: The terminal can measure a ground current of 20–20000 mA.

Average Current

Description

The LTMT main unit calculates the RMS value of the average current using the measured line currents.

$$I_{avg} = \frac{I_{L1} + I_{L2} + I_{L3}}{3}$$

Characteristics

Characteristic	Value
Unit	Ampere (A)
Resolution	0.001 A
Refresh interval	20 ms

Current Imbalance

Description

The current imbalance function measures the maximum percentage of deviation between the average current and the individual phase currents.

The current imbalance measurement is based on imbalance ratio calculated from the following formulas:

Calculated measurement	Formula
If $I_{avg} \geq I_{FLC}$	$UB\% = \frac{ I_{Lx} - I_{avg} }{I_{avg}} \times 100\%$
If $I_{avg} \leq I_{FLC}$	$UB\% = \frac{ I_{Lx} - I_{avg} }{I_{FLC}} \times 100\%$
Where <ul style="list-style-type: none"> • I_{avg} = Average RMS phase current • I_{Lx} = RMS current in the phase with maximum deviation from I_{avg} • I_{FLC} = Motor full load current setpoint 	

NOTE: Current imbalance is not available in single-phase mode.

Characteristics

The current imbalance function has the following characteristics:

Characteristic	Value
Unit	%
Resolution	1%
Refresh interval	100 ms

Current Phase Sequence

The LTMT main unit detects the current phase sequence of three-phase motor supply.

- **L123:** L1 current at angle 0° , L2 current at angle 240° , L3 current at angle 120° .
- **L132:** L1 current at angle 0° , L2 current at angle 120° , L3 current at angle 240° .
- **CTWF:** Current transformer wiring trip detected by the LTMT main unit. For example, one of the three phases is wired in opposite direction.

NOTE: Current phase sequence is not available in single-phase mode.

Voltage Measurement

What's in This Chapter

Overview	62
RMS Voltage.....	62
Average Voltage.....	63
Voltage Imbalance.....	64
Voltage Phase Sequence	65
Frequency	66

Overview

The voltage measurement parameters are applicable only for LTMT main unit with LTMTCTV sensor modules.

RMS Voltage

Description

The line-to-line voltages function provides the RMS value of the phase-to-phase voltage (VL1–L2, VL2–L3, and VL3–L1):

- VL1–L2 voltage: Phase 1 to Phase 2 RMS voltage
- VL2–L3 voltage: Phase 2 to Phase 3 RMS voltage
- VL3–L1 voltage: Phase 3 to Phase 1 RMS voltage

In single-phase mode:

VL1 voltage: Phase to neutral RMS voltage

Characteristics

Characteristic	Value
Unit	Volts (V)
Resolution	0.1 V
Refresh interval	20 ms

Average Voltage

Description

The LTMT main unit calculates average voltage and provides the value in Volts. The average voltage function returns the RMS value of the average voltage.

The LTMT main unit calculates average voltage using the measured line-to-line voltages.

The average voltage of three-phase motor is calculated using the formula:

$$V_{avg} = \frac{VL1-L2 + VL2-L3 + VL3-L1}{3}$$

Characteristics

Characteristic	Value
Unit	Volts (V)
Resolution	0.1 V
Refresh Interval	20 ms

Voltage Imbalance

Description

The line voltage imbalance function displays the maximum percentage of deviation between the average voltage and the individual line voltages.

The three-phase voltage imbalance is calculated using formula:

$$\%V_{UB} = \frac{|VLx - V_{avg}|}{V_{avg}} \times 100$$

Where,

- VLx= Maximum deviated line voltage from average voltage
- Vavg = Average voltage of the three phases

NOTE: Not applicable in single-phase mode.

Characteristics

The line voltage imbalance function has the following characteristics:

Characteristic	Value
Unit	%
Accuracy	+/- 1.5%
Resolution	1%
Refresh interval	100 ms

Voltage Phase Sequence

The LTMT main unit detects the voltage phase sequence of three-phase motor supply.

- **L123:** L1 voltage at angle 0° , L2 voltage at angle 240° , L3 voltage at angle 120° .
- **L132:** L1 voltage at angle 0° , L2 voltage at angle 120° , L3 voltage at angle 240° .

NOTE: Not applicable in single-phase mode.

Frequency

Description

The LTMT main unit measures the frequency of the three-phase voltage supplied to the motor. The frequency function provides the value measured based on the phase 1 voltage. In case of loss of phase 1 voltage, the frequency is not measured.

Characteristics

Characteristic	Value
Unit	Hz
Resolution	0.01 Hz
Refresh Interval	20 ms

Power and Energy Measurement

What's in This Chapter

Overview	68
Active Power, Reactive Power, and Apparent Power	68
Active Energy, Reactive Energy, and Apparent Energy	69
Power Factor	70

Overview

The power and energy values are calculated by LTMT main unit with LTMTCTV sensor module.

Active Power, Reactive Power, and Apparent Power

Three-Phase Motor

The formula for active power, reactive power, and apparent power for the three-phase motor are as follows:

- The active power, also known as true power, measures average RMS power. Total active power for three-phase motor P (kW) is derived from the following formula:

$$P \text{ (kW)} = \frac{|(VL1 \times IL1 \times \cos\phi1) + (VL2 \times IL2 \times \cos\phi2) + (VL3 \times IL3 \times \cos\phi3)|}{1000}$$

- The reactive power measurement Q (kVAR) is derived from the following formula:

$$Q \text{ (kVAR)} = \frac{|(VL1 \times IL1 \times \sin\phi1) + (VL2 \times IL2 \times \sin\phi2) + (VL3 \times IL3 \times \sin\phi3)|}{1000}$$

- The apparent power measurement S (kVA) is derived from the following formula:

$$S \text{ (kVA)} = \frac{|(VL1 \times IL1) + (VL2 \times IL2) + (VL3 \times IL3)|}{1000}$$

Single-Phase Motor

The formula for active power, reactive power, and apparent power for the single-phase motor are as follows:

- Active power: $P \text{ (kW)} = |(VL1 \times IL1 \times \cos\phi)|$
- Reactive power: $Q \text{ (kVAR)} = |(VL1 \times IL1 \times \sin\phi)|$
- Apparent power: $S \text{ (kVA)} = |(VL1 \times IL1)|$

Active Energy, Reactive Energy, and Apparent Energy

The energies are derived from the following formulas:

- Total active energy: $EP \text{ (kWh)} = P \times \text{Hours}$
- Total reactive energy: $EQ \text{ (kVARh)} = Q \times \text{Hours}$
- Total apparent energy: $ES \text{ (kVAh)} = S \times \text{Hours}$

Power Factor

Description

The power factor displays the phase displacement between phase currents and phase voltages.

The power factor (also called cosine phi or $\cos \phi$ or $\cos \varphi$) represents the absolute value of the ratio of active power to apparent power.

The following diagram displays an example of the average RMS current sinusoidal curve lagging slightly behind the average RMS voltage sinusoidal curve, and the phase angle difference between the two curves:

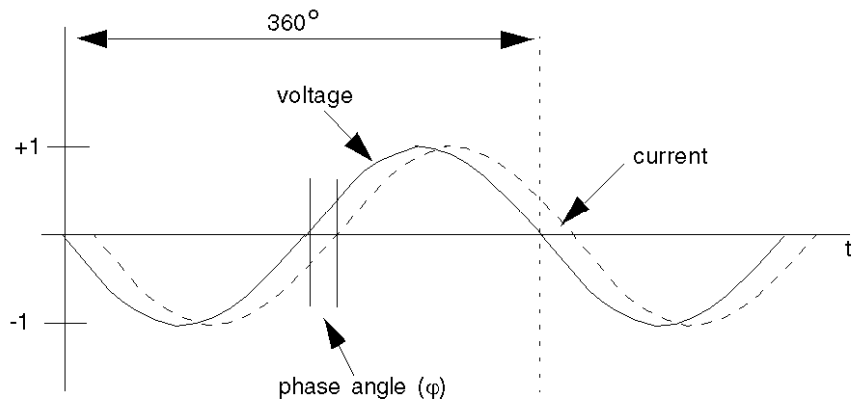

After the phase angle (ϕ) is measured, the power factor can be calculated as the cosine of the phase angle (ϕ)-the ratio of side a (active power) over the hypotenuse h (apparent power):

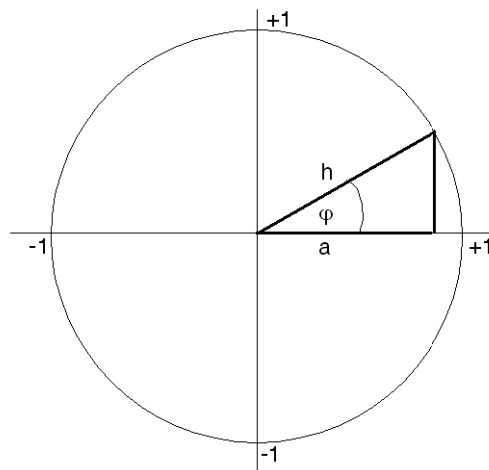

Characteristics

The power factor has the following characteristics:

Characteristic	Value
Power factor range	0.40–1.00
Accuracy ⁽¹²⁾	± 3–6%
Resolution	0.01
Refresh interval	100 ms

⁽¹²⁾ Valid under balanced conditions.

THD Metering for Current and Voltage

The LTMT main unit measures:

- The Total Harmonic Distortion (THD) of the three-phase currents:
 - L1 current THD
 - L2 current THD
 - L3 current THD
- The THD of the three-phase voltages, when voltages are measured by a LTMTCTV sensor module:
 - L1–L2 voltage THD
 - L2–L3 voltage THD
 - L3–L1 voltage THD
- The THD of the single-phase voltage:
 - L1–N voltage THD
 - L1 current THD

The THD is measured up to the seventh harmonic.

Characteristics	Value
Unit	%
Resolution	1 %
Refresh interval	100 ms

NOTE: The harmonics (THD current and voltage) are not measured if the signal is less than 10% of the reference value (IFLC or V_n). By default, harmonics below 10% are not measured.

Temperature Measurement

The TeSys Tera system supports maximum 1 temperature inputs for LTMT main unit.

Temperature Measured by LTMT Main Unit

The LTMT main unit temperature input can be connected to a 2-wire temperature sensor.

One of the following types of temperature sensors can be used:

- PT100
- PTC (Binary)

Characteristic	PT100 temperature sensor	Binary PTC resistance temperature sensor
Range	25 to 100 °C	2700 to 4000 Ω
Resolution	0.1 °C	1 Ω
Refresh interval	500 ms	500 ms

Analog Input Measurement

A maximum of four analog inputs can be connected to LTMT main unit through two LTMTAN21 expansion modules to get analog measurements. Each module has two analog inputs.

Characteristic	Value
Range	4–20 mA
Unit	mA
Resolution	0.1
Refresh Interval	100 ms

Analog Output Measurement

A maximum of two analog outputs can be connected to two LTMTAN21 expansion modules to get analog measurements. Each module has one analog outputs.

Characteristic	Value
Range	4–20 mA
Unit	mA
Resolution	0.1
Refresh Interval	100 ms

Monitoring Functions

What's in This Part

Overview	77
Thermal Memory	78
Thermal Time to Trip.....	79
Thermal Time to Cool	80
Motor History	81
Motor Status	83
Inhibit Status	84
System Self-Diagnostic.....	86
Test Functions.....	87
Communication Loss	90
HMI Communication Loss	91
Monitoring Records	92

Overview

All parameter values are accessible from the LTMT main unit using following interfaces:

- A PC running the TeSys Tera DTM embedded in a FDT container such as SoMove software.
- The LTMTCUF control operator unit.
- A PLC or DCS through the communication network.

Thermal Memory

Description

The LTMT main unit calculates the thermal memory based on the trip class and service factor parameters of thermal overload protection settings.

Characteristics

Characteristic	Value
Unit	%
Resolution	1 %
Refresh interval	20 ms

Thermal Time to Trip

Description

The LTMT main unit displays the time to trip for thermal protection. Based on thermal memory, the LTMT main unit calculates the time remaining before tripping of the thermal protection.

Characteristics

Characteristic	Value
Unit	s
Resolution	1 s
Refresh interval	1 s

Thermal Time to Cool

Description

The LTMT main unit displays the time to cool when motor is stopped or tripped. Based on the trip class and service factor parameters of thermal overload protection settings, the LTMT main unit calculates the time to cool and keeps the LTMT main unit in inhibit state.

Characteristics

Characteristic	Value
Unit	s
Resolution	1 s
Refresh interval	1 s

Motor History

Maximum Start Counter

The LTMT main unit counts the number of motor starts within a given period of time. The number of motor starts is used by the function *Maximum Number of Starts*, page 170.

Maximum Start Inhibit Time

The LTMT main unit tracks the maximum start inhibit time. The maximum start inhibit time is defined by the function *Maximum Number of Starts*, page 170.

Motor Starting Peak Current

The LTMT main unit tracks the maximum current drawn by the motor during the start time. When the motor goes to Start state, the LTMT main unit starts recording the starting peak current. When the motor goes to Run or Stop state, the LTMT main unit stops recording the starting peak current.

Motor Starting Time

The LTMT main unit records the time when the motor goes to Start state. The LTMT main unit stops recording the time when the motor goes to Run or Stop state.

Total Run Hour

The LTMT main unit records the total run hour from the factory reset or **Reset total run hour** command.

Last Run Hour

The LTMT main unit measures the number of hours the motor has run from the time it has last been started.

Number of Starts

The LTMT main unit counts the total number of times the motor has started.

The number of starts is reset to zero by:

- Return to default values command.
- Reset number of starts command.

Number of Stops

The LTMT main unit counts the total number of times the motor has stopped.

The number of stops is reset to zero by:

- Return to default values command.
- Reset number of stops command.

Motor Stop Cause

Motor stop cause	Description
HMI	Motor stopped on command received from LTMTCUF control operator unit.
Local DI	Motor stopped on Local Stop DI input detection.
Remote DI	Motor stopped on Remote DI input detection.
Communication	Motor stopped on command received from PLC or DCS.
Auto restart	Motor stopped by auto restart function.
Trip	Motor stopped due to trip.
No current	Motor stopped as the current is zero.
Forced Stop	Motor stopped on Forced Stop input.
Direction change	Motor stopped to change direction by reverse type of starters.
No feedback	Motor stopped as no feedback received (either current feedback or RUN DI).
Speed change	Motor stopped to change speed on command received (applicable for two speed starters).
Custom command	Motor stopped on Custom command detection.
Mode transfer	Motor stopped due to mode change if Bump mode is enabled.
No Voltage	Motor is stopped due to no voltage detected.

Motor Status

⚠ WARNING
UNINTENDED EQUIPMENT OPERATION
When the motor current drops below 10% of IFLC, the LTMCUF control operator unit displays 0. Make sure the motor is completely in the STOP position before carrying out any maintenance activities.
Failure to follow these instructions can result in death, serious injury, or equipment damage.

The LTMT main unit defines the motor status based on maximum of three-phase current (IMAX) and full load current (IFLC) setting.

Motor status	Description
Stop	Motor stopped if IMAX < 10% of IFLC.
Start	Motor starting if IMAX ≥ 10% of IFLC.
Run	Motor running if IMAX goes above the Run threshold + 10% and comes below the Run threshold. Run threshold (RT) is a parameter of the Excessive start time function.

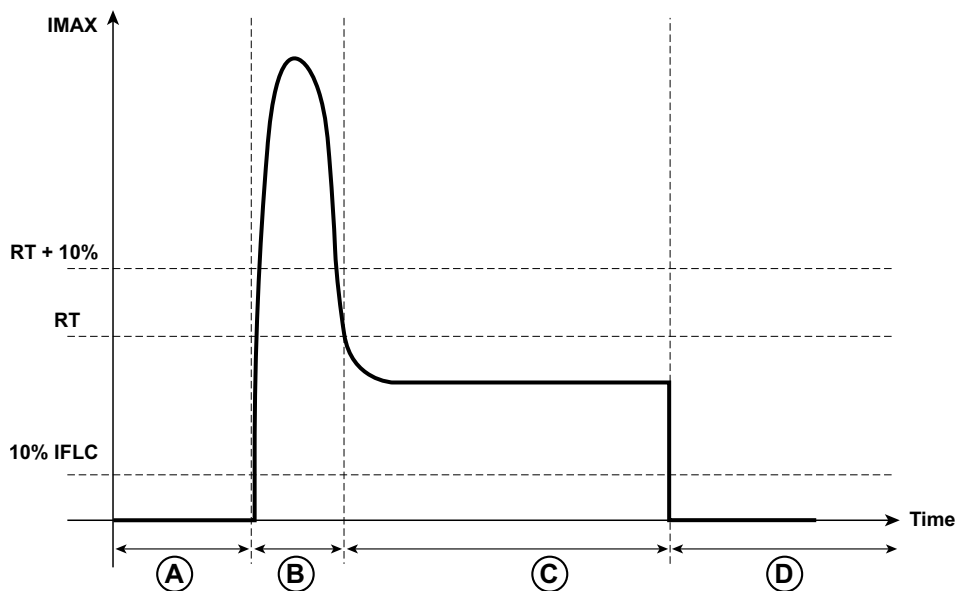

- A Stop
- B Start
- C Run
- D Stop

Heater Status

The LTMT main unit defines the heater status based on maximum of three-phase current (IMAX) and full load current (IFLC) setting.

Heater status	Description
OFF	Heater in OFF state if IMAX < 10% of IFLC.
ON	Heater in ON state if IMAX ≥ 15% of IFLC for 100 ms.

Inhibit Status

Description

Inhibit status is a pre-start condition of motor. If any of the inhibit cause is present, TeSys Tera system will not allow the motor to start.

The list of inhibit cause depends on the motor starter function selected.

Inhibit Cause

Inhibit cause	Description	Validity
No Voltage Inhibit	This inhibit cause is set if TeSys Tera system measures the three-phase voltage below 10% of nominal voltage.	Valid for all motor starter types. This inhibit status is applicable only for the LTMCTV sensor module and if the Voltage input setting is enabled in system settings.
Under Voltage Inhibit	This inhibit cause is set if TeSys Tera system detects under voltage pickup/alarm.	Valid for all motor starter types. This inhibit status is applicable only for the LTMCTV sensor module and if the Voltage input setting is enabled in system settings.
Trip Inhibit	This inhibit cause is set if TeSys Tera system is in trip condition.	Valid for all motor starter types.
Thermal Inhibit	This inhibit cause is set if the thermal memory is greater than the start inhibit level setting of the thermal overload protection. This inhibit cause is also set if the pause time (if pause time function is enabled), or the cool down time (if cool down time function is enabled) is active.	Valid for all motor starter types.
Maximum Starts Inhibit	This inhibit cause is set if: <ul style="list-style-type: none"> Maximum start protection is enabled. The maximum starts are performed as per the configured setting or if time between the two starts period is not elapsed. 	Valid for all motor starter types.
Interlock 1-12 Inhibit	This inhibit cause is set if: <ul style="list-style-type: none"> DI of TeSys Tera system is configured as Interlock. DI status is detected as OFF. 	Valid for all motor starter types.
Local DI Stop Inhibit	This inhibit cause is set if: <ul style="list-style-type: none"> Local DI stop is configured in one of the DI settings. Local DI stop status is ON and Local DI stop is enabled in active mode. 	Valid for all motor starter types.
Remote DI Stop Inhibit	This inhibit cause is set if: <ul style="list-style-type: none"> Remote DI stop is configured in one of the DI settings. Remote DI stop status is ON and Remote DI stop is enabled in active mode. 	Valid for all motor starter types.
Forced Stop Inhibit	This inhibit cause is set if <ul style="list-style-type: none"> Forced Stop is configured in DI settings. Forced Stop status is detected as ON. 	Valid for all motor starter types.
Communication Stop Inhibit	This inhibit cause is set if, communication stop status is present and communication stop is enabled in active mode.	Valid for all motor starter types. This inhibit status is applicable only, if the communication start input setting in starter setting is configured as momentary.
Anti-backspin Inhibit	This inhibit cause is set if Anti-backspin timer function is enabled and Anti-backspin timer is active after motor stop. Refer to Anti-Backspin Timer, page 180.	Valid for all motor starter types.
Direction Change Inhibit	In reverse starters, this inhibit cause is set if the Interlock timer is active after motor stops.	Valid for the reversing motor starter types.

Custom Stop Inhibit	This inhibit cause is set if: <ul style="list-style-type: none">Any input is configured to Custom stop input of temporary register 29.The Custom stop input status is ON and Custom stop input is enabled in active mode.	Valid for custom logic 256 to 511.
Firmware Update Inhibit	When firmware device update is in progress.	Valid for all motor starter types.

System Self-Diagnostic

Description

The LTMT main unit carries out a series of self tests to monitor:

- Correct internal functioning of the LTMT main unit.
- Correct functioning of the modules connected to the LTMT main unit.
- Communication with the modules connected to the LTMT main unit.

The device internal error detected by the self tests are accessible from the LTMT main unit using the following interfaces:

- A PC running SoMove FDT container software with TeSys Tera DTM installed and equipped with standard web server capability.
- The LTMTCUF control operator unit.
- A PLC or DCS through the communication network.

The last 20 detected device internal error detected are recorded by the LTMT main unit. Refer to *Device Internal Records*, page 93.

In case of device internal error detected, refer to the troubleshooting part in the *TeSys Tera Motor Management System Installation Guide – DOCA0356EN*.

Device Internal Error Detected

The motor or heater is stopped or inhibited by the motor starter logic when the following device internal error detected:

- Sensor module communication error detected.
- LTMT expansion module communication error detected.
- Error detected during LTMT expansion module initialization.
- Configuration error detected.

Test Functions

If a device was tested in free air, the information will note that the device is not evaluated for use in an individual enclosure.

Self Test Without Trip

⚠ WARNING
UNINTENDED EQUIPMENT OPERATION
If the motor is connected to the contactor then there will be possibility of starting the motor for few seconds.
Failure to follow these instructions can result in death, serious injury, or equipment damage.

Press **Test/Reset** button for 3 to 15 s to perform a self test without trip. When the button is released, the LTMT main unit LED will turn **ON** in pattern 1 for 1 s. After 1 s, the LTMT main unit LED will turn **ON** in pattern 2 for 1 s. After 2 s from the beginning of the test, LTMT main unit comes out of the test mode.

LEDs	Pattern 1 LED status	Pattern 2 LED status
Device	●	●
Communication	●	●
NS	●	●
Motor Status	●	○
Trip/Alarm	●	●

The graphical representation of self test mode without trip is shown below:

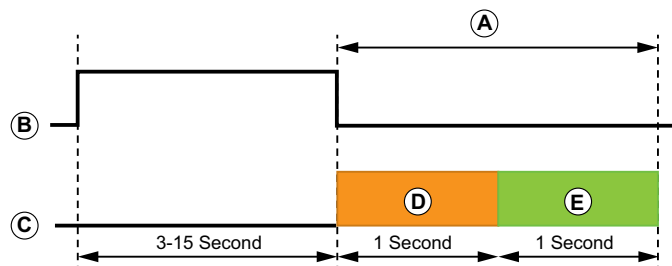

- A Self test mode without trip
- B Reset button
- C LEDs
- D Pattern1
- E Pattern2

Self Test With Trip (If Motor is Stopped)

⚠ WARNING

UNINTENDED EQUIPMENT OPERATION

If the motor is connected to the contactor then there will be possibility of starting the motor for few seconds.

Failure to follow these instructions can result in death, serious injury, or equipment damage.

When a self test with trip command is received from LTMT CUF control operator unit, communication network or a digital input of the LTMT main unit:

- The LTMT main unit LED will turn on in pattern 1 for 1 s. After 1 s, the LTMT main unit LEDs will turn on in pattern 2 for 1 s.
- The state of the trip digital output changes for 2 s.
- After 2 s from the beginning of the test, the LTMT main unit comes out of the test mode, and the state of the trip digital output will change.

LEDs	Pattern 1 LED status	Pattern 2 LED status
Device	●	●
Communication	●	●
NS	●	●
Motor Status	●	○
Trip/Alarm	●	●

The graphical representation of self test mode with trip is shown below:

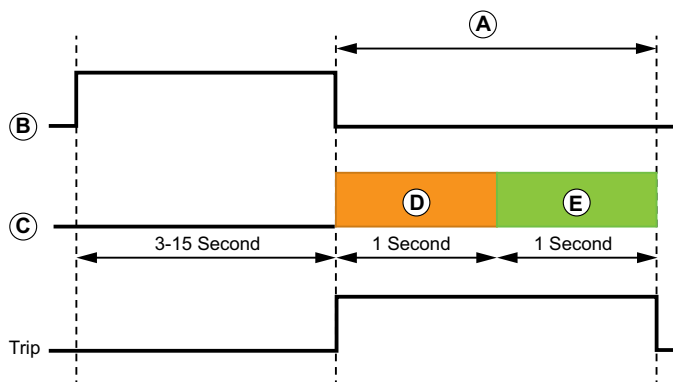

- A Self test mode with trip
- B Reset button
- C LEDs
- D Pattern1
- E Pattern2

Logic Test Mode

▲ WARNING

UNEXPECTED BEHAVIOUR OF EQUIPMENT

The motor may turn on for few milli seconds before the TeSys Tera system trips while operating in Logic Test Mode.

Failure to follow these instructions can result in death, serious injury, or equipment damage.

The logic test function of the LTMT main unit can be used during commissioning of the motor. This function helps to check the wiring of the motor with LTMT main unit. Any one of the digital input of the LTMT main unit should be configured as logic test DI. The LTMT main unit enters into or exits from the logic test mode depending on the status of the logic test DI.

In logic test mode, the LTMT main unit allows you to start or stop the motor (contactors) to verify the wiring and bypass the following inhibit conditions:

- Thermal memory inhibit
- Max start inhibit
- Low voltage inhibit
- No voltage inhibit

In logic test mode, the LTMT main unit allows to reset the trip or auto resets the trip.

The LTMT main unit exits from the logic test mode in the following case:

- Voltage detected by LTMTCTV sensor module.
- Current detected by LTMTCT/LTMTCTV sensor module.
- Logic test DI status is OFF.

The logic test mode can be set up using following interfaces:

- A PC running SoMove FDT container software with TeSys Tera DTM installed and equipped with standard web server capability
- The LTMTCUF control operator unit.
- A PLC or DCS through the communication network.

Communication Loss

Description

Communication loss function:

- Detects the loss of communication between the LTMT main unit and the PLC or DCS connected through the communication network, once communication has been established.
- Generates an alarm or a trip action according to the function setting.

When **Trip in Remote Mode only** setting is enabled, the LTMT main unit sends the trip command only when the motor is running in Remote mode. If the motor is running in Local mode, the LTMT main unit sends only the alarm signal.

Parameter Setting

Parameter	Range	Default value
Function	<ul style="list-style-type: none"> • Disable • Alarm • Alarm + Trip • Trip 	Disable
Time Delay	0.1 – 6000.0 s in step of 0.1 s	1 s
Reset Mode	<ul style="list-style-type: none"> • Reset key • DI • Communication • Auto 	DI + Reset Key
Auto-Reset Delay (Applicable only if Reset mode is Auto)	0.0 – 6000.0 s in step of 0.1 s	0 s
Trip in Remote Mode Only	<ul style="list-style-type: none"> • Disable • Enable 	Disable

HMI Communication Loss

Description

HMI Communication loss function:

- Detects the loss of communication between the LTMT main unit and the HMI connected via the HMI port, once communication has been established.
- Generates an alarm or a trip action according to the function setting.

Parameter Setting

Parameter	Range	Default value
Function	<ul style="list-style-type: none">• Disable• Alarm• Trip• Alarm + Trip	Disable
Time Delay	0.1 – 6000.0 s in step of 0.1 s	1 s
Reset Mode	<ul style="list-style-type: none">• Reset key• DI• Communication• Auto	DI + Reset Key
Auto Reset Delay	0.0 – 6000.0 s in step of 0.1 s	0 s

Monitoring Records

Description

The data recording function of LTMT main unit keeps time stamped data records for further diagnostics. This function helps to record the sequence of events that has occurred.

There are different types of data recorded such as trip records, event records, and device internal records.

The records are available through:

- A PC running SoMove FDT container software with TeSys Tera DTM installed and equipped with standard web server capability.
- The LTMTCUF control operator unit.
- A PLC or DCS through the communication network.

Date and Time

The LTMT main unit date and time is used to time stamp the data records.

The date and time can be configured using:

- PC running SoMove FDT container software with TeSys Tera DTM installed and equipped with standard web server capability.
- The LTMTCUF control operator unit.
- A PLC or DCS through the communication network.

Trip Records

The LTMT main unit records the last 20 encountered trips. Each trip record contains the following information:

- Record ID
- Time stamp
- Trip cause
- Following values are recorded at the time of the trip:
 - Thermal memory
 - RMS and ground currents
 - RMS voltages
 - Current and voltage imbalances
 - Current and voltage THD
 - Current and voltage phase sequence
 - Active power
 - Power factor
 - Frequency
 - Motor status
 - Full load current of motor
 - Temperature input
 - Analog input
 - Trip code

For more information on trip codes, refer to [Trip Code](#), page 186.

Event Records

The LTMT main unit records the last 100 encountered events. Each event record contains the following information:

- Record ID
- Time Stamp
- Event
- Event Code

For more information on event codes, refer to [Event Code](#), page 188 .

Device Internal Records

The LTMT main unit records the last 20 internal detected errors. Each device internal record contains the following information:

- Record ID
- Time Stamp
- Event
- Event Code

For more information on device internal detection codes, refer to [Device Internal Error Code](#), page 206.

Motor Start Curve Records

The LTMT main unit records 250 current values measured during the last motor start. The sampling interval is computed internally by the LTMT main unit, based on the trip class setting of thermal overload protection.

Refer the following table for motor start curve sampling interval:

Trip class	Sampling interval
5	20 ms
10	40 ms
15	60 ms
20	80 ms
25	100 ms
30	120 ms
35	140 ms
40	160 ms

One record can be saved to serve as motor start reference record.

The last motor start curve record can be saved as reference record by using:

- TeSys Tera DTM.
- Command from a PLC or DCS through the communication network.

The last motor start curve record and the reference record:

- Can be displayed with the TeSys Tera DTM.
- Are available for PLC or DCS through the communication network.

Protection Functions

What's in This Part

Protection Settings	95
Motor Protection Functions	100
Current Protection Functions.....	110
Voltage Protection Functions.....	121
Power Protection Functions	127
Digital Input Interlock	133
Analog Input Protection.....	134
AO Settings	135

▲ WARNING

UNINTENDED EQUIPMENT OPERATION

The application of this product requires expertise in the design and programming of control systems. Only personnel with such expertise should be allowed to program, install, configure, alter and apply this product. Follow all local and national safety codes and standards.

Failure to follow these instructions can result in death, serious injury, or equipment damage.

Protection Settings

What's in This Chapter

Function Parameter.....	96
Reset Modes	98
Hysteresis Setting	99

Function Parameter

The function parameter of each protection can be set separately to define the action of the protection function on the system.

Function parameter value	Description
Disable	The protection function is disabled.
Alarm	The protection function is used to signal the alarm conditions. The alarm is not latched and it is automatically reset when the alarm conditions have disappeared.
Alarm + Trip	The protection function is used to signal the alarm conditions and to stop the motor in the trip conditions.
Trip	The protection function is used to stop the motor in the trip conditions. The trip conditions are defined in the description of each protection function. The trip is latched and must be reset according to the Reset mode set for protection function.

Detection of Alarm

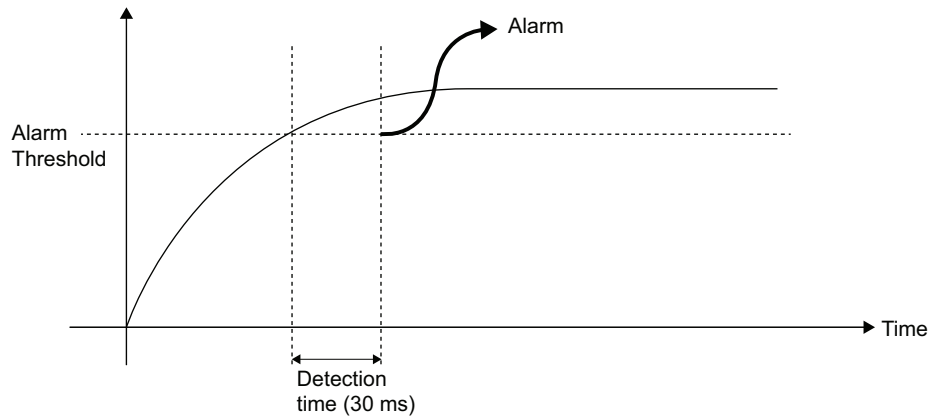

LTMT main unit detects the alarm in 30 ms of time after the parameter value crosses the alarm threshold.

Detection of Pickup and Trip

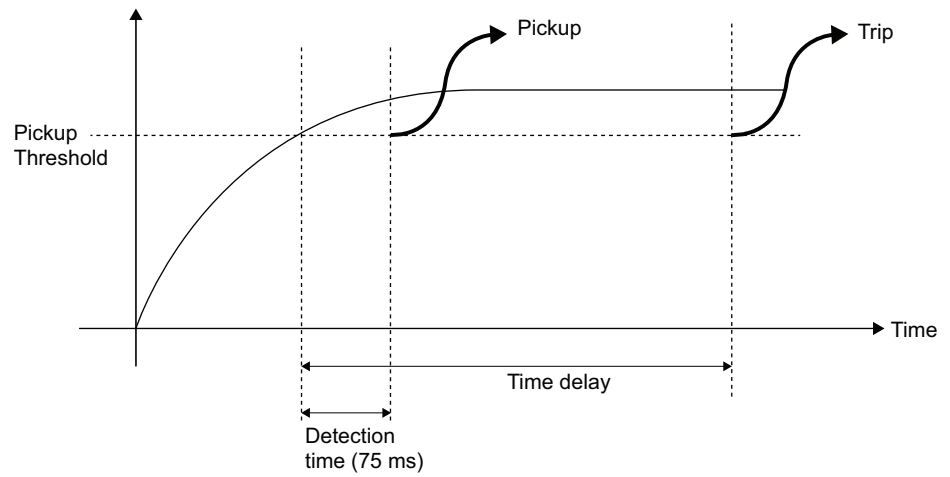

LTMT main unit detects:

- Pickup in 75 ms of time, after the parameter value crosses the pickup threshold.
- Trip, after the parameter value crosses the pickup threshold and remain above the pickup threshold for configured time delay.

Reset Modes

⚠ WARNING

UNINTENDED EQUIPMENT OPERATION

- A reset command will immediately restart the motor if the LTMT main unit is operating in a maintained mode and corresponding start input is ON.
- Equipment operation must conform to local and national safety regulations and codes.
- This equipment must only be operated by qualified electrical personnel.

Failure to follow these instructions can result in death, serious injury, or equipment damage.

The reset mode of each protection function can be set separately. The reset mode defines the reset possibility of the protection function once tripped. The several reset modes can be set for the same protection function.

Reset mode	Description
Auto	For thermal overload protection, the trip resets automatically once the thermal memory drops below the thermal reset level. For other protections, the trip resets automatically, if the pickup is reset and after the auto reset time is elapsed.
Reset Key	Trip reset is possible through Reset button on LTMTCUF control operator unit or Reset button on the LTMT main unit or Trip Reset in DTM control panel section.
DI	Trip reset is possible through digital input. One of the digital inputs must be configured as trip reset signal.
Communication	Trip reset is possible from PLC or DCS through the communication network.

Hysteresis Setting

Description

Hysteresis Setting are used for calculating reset threshold of protection alarm and pickup.

Pickup or alarm threshold are set by protection settings. For reset threshold calculation LTMT main unit uses **Hysteresis Setting**.

For example, if overcurrent protection pickup is set at 100% of full load current (IFLC), and if **Hysteresis Setting** for current protections is set at 3%, the pickup reset threshold level for overcurrent protection is 97% of IFCL.

Over protections:

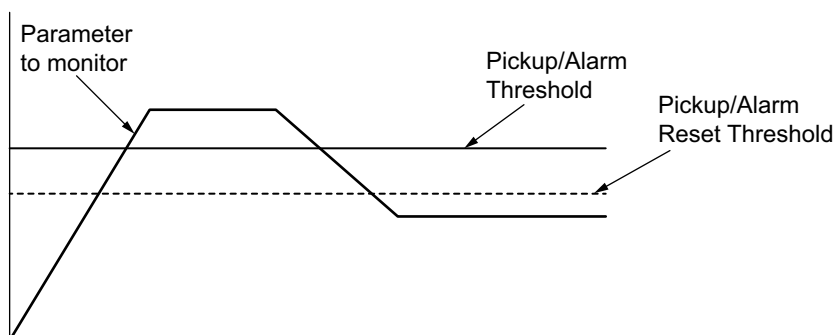

Under protections:

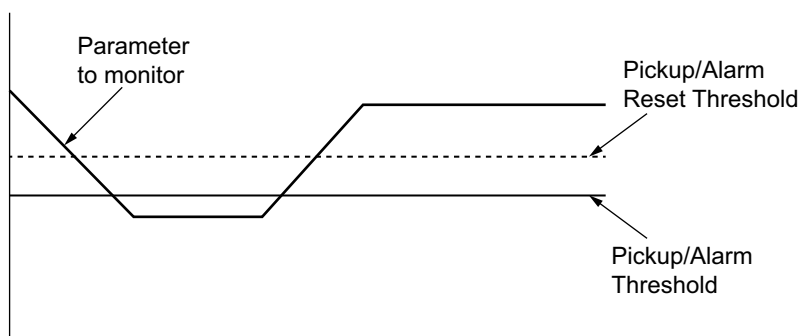

Hysteresis is fixed for the following protections:

- Voltage phase loss - 35% of imbalance
- Current phase loss - 15% of IFCL
- Voltage imbalance - 3% of imbalance

Parameter Settings

Parameter	Setting range	Default value
Current protection	3–15 % in step of 1%	3%
Voltage protection	3–15 % in step of 1%	3%
Frequency protection	1–15 % in step of 1%	3%
Power protection	3–15 % in step of 1%	3%
Analog input protection	1–3 mA in step of 1 mA	1 mA
Temperature protection	2–15 °C in step of 1 °C	5 °C

Motor Protection Functions

What's in This Chapter

Thermal Overload	101
Locked Rotor	107
Stall Rotor.....	108
Temperature Protection	109

Thermal Overload

Description

The thermal overload is a condition where current higher than the rated value flows to the motor resulting in excessive heating of the motor. Rapid motor heating occurs during the overload, acceleration time, and locked rotor condition. The LTMT main unit computes the thermal memory (TM) as per the motor running current.

The thermal overload protection function generates the following signals:

- Alarm: Thermal memory goes above the alarm level.
- Trip: Thermal memory reaches to 100%.
- Thermal Inhibit: When the motor is stopped and thermal memory is above the start thermal inhibit level.

The following graph shows the thermal overload protection curve:

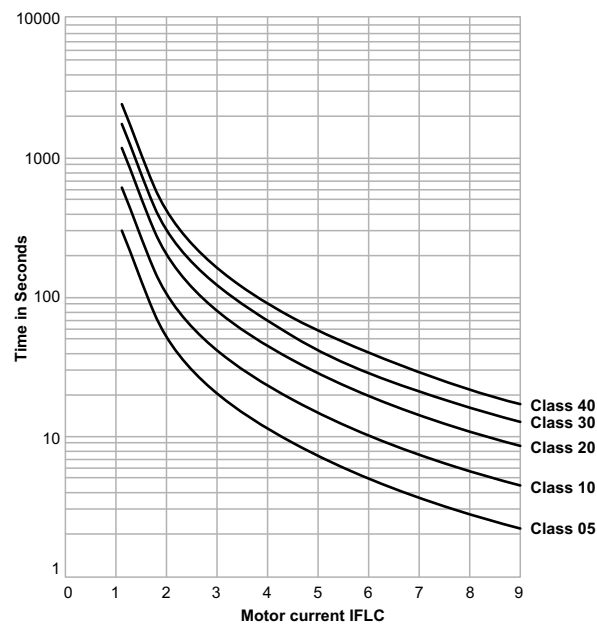

Trip Time Chart

The **Thermal Overload Protection** function supports different trip classes and service factor setting. The following tables shows the **Thermal Overload Protection** trip time with respect to motor current, trip class setting, and service factor setting.

Service factor	Motor current (x IFLC)	Trip time (s)							
		Class 5	Class 10	Class 15	Class 20	Class 25	Class 30	Class 35	Class 40
1.00	7.20	3.46	6.91	10.37	13.83	17.29	20.74	24.20	27.66
	6.00	5.00	10.00	15.00	20.00	25.00	30.00	35.00	40.00
	5.00	7.25	14.49	21.74	28.98	36.23	43.47	50.72	57.96
	4.00	11.45	22.91	34.36	45.82	57.27	68.73	80.18	91.64
	3.00	20.91	41.81	62.72	83.62	104.53	125.43	146.34	167.24
	2.00	51.06	102.12	153.18	204.24	255.30	306.36	357.42	408.48
	1.50	104.33	208.65	312.98	417.30	521.63	625.95	730.28	834.60
	1.00	No trip	No trip	No trip	No trip	No trip	No trip	No trip	No trip
1.05	7.20	3.82	7.63	11.45	15.26	19.08	22.89	26.71	30.52

Service factor	Motor current (x IFLC)	Trip time (s)							
		Class 5	Class 10	Class 15	Class 20	Class 25	Class 30	Class 35	Class 40
	6.00	5.52	11.04	16.56	22.08	27.60	33.12	38.64	44.16
	5.00	8.01	16.01	24.02	32.02	40.03	48.03	56.04	64.04
	4.00	12.67	25.34	38.02	50.69	63.36	76.03	88.70	101.37
	3.00	23.19	46.39	69.58	92.78	115.97	139.16	162.36	185.55
	2.00	57.23	114.46	171.69	228.92	286.15	343.38	400.61	457.84
	1.50	119.51	239.02	358.53	478.04	597.55	717.06	836.58	956.09
	1.05	No trip	No trip	No trip	No trip	No trip	No trip	No trip	No trip
1.10	7.20	4.19	8.38	12.58	16.77	20.96	25.15	29.34	33.54
	6.00	6.07	12.14	18.20	24.27	30.34	36.41	42.48	48.55
	5.00	8.81	17.61	26.42	35.22	44.03	52.83	61.64	70.44
	4.00	13.96	27.91	41.87	55.83	69.79	83.74	97.70	111.66
	3.00	25.63	51.25	76.88	102.51	128.13	153.76	179.38	205.01
	2.00	63.94	127.88	191.82	255.76	319.70	383.64	447.58	511.53
	1.50	136.97	273.94	410.91	547.88	684.85	821.82	958.79	1095.76
1.10	No trip	No trip	No trip	No trip	No trip	No trip	No trip	No trip	No trip
1.15	7.20	4.59	9.17	13.76	18.35	22.93	27.52	32.11	36.69
	6.00	6.64	13.29	19.93	26.57	33.22	39.86	46.50	53.14
	5.00	9.65	19.29	28.94	38.59	48.23	57.88	67.53	77.17
	4.00	15.31	30.62	45.94	61.25	76.56	91.87	107.19	122.50
	3.00	28.21	56.42	84.62	112.83	141.04	169.25	197.46	225.67
	2.00	71.25	142.49	213.74	284.98	356.23	427.47	498.72	569.97
	1.50	157.29	314.58	471.87	629.16	786.44	943.73	1101.02	1258.31
1.15	No trip	No trip	No trip	No trip	No trip	No trip	No trip	No trip	No trip
1.20	7.20	5.00	10.00	15.00	20.00	25.00	30.00	35.00	40.00
	6.00	7.25	14.49	21.74	28.98	36.23	43.47	50.72	57.96
	4.00	16.74	33.48	50.22	66.96	83.70	100.43	117.17	133.91
	3.00	30.95	61.89	92.84	123.78	154.73	185.67	216.62	247.57
	2.00	79.21	158.42	237.63	316.84	396.05	475.26	554.48	633.69
	1.50	181.33	362.66	543.99	725.32	906.66	1087.99	1269.32	1450.65
	1.20	No trip	No trip	No trip	No trip	No trip	No trip	No trip	No trip
1.25	7.20	5.43	10.86	16.30	21.73	27.16	32.59	38.02	43.46
	6.00	7.88	15.75	23.63	31.50	39.38	47.25	55.13	63.01
	5.00	11.45	22.91	34.36	45.82	57.27	68.73	80.18	91.64
	4.00	18.24	36.48	54.72	72.95	91.19	109.43	127.67	145.91
	3.00	33.85	67.69	101.54	135.38	169.23	203.07	236.92	270.76
	2.00	87.91	175.83	263.74	351.65	439.57	527.48	615.40	703.31
	1.50	210.43	420.87	631.30	841.74	1052.17	1262.61	1473.04	1683.47
1.25	No trip	No trip	No trip	No trip	No trip	No trip	No trip	No trip	No trip
1.30	7.20	5.88	11.77	17.65	23.53	29.41	35.30	41.18	47.06
	6.00	8.53	17.07	25.60	34.14	42.67	51.20	59.74	68.27
	5.00	12.42	24.85	37.27	49.69	62.12	74.54	86.96	99.38
	4.00	19.81	39.63	59.44	79.25	99.07	118.88	138.69	158.50
	3.00	36.91	73.83	110.74	147.66	184.57	221.49	258.40	295.31
	2.00	97.45	194.90	292.35	389.80	487.25	584.70	682.15	779.59
	1.50	246.84	493.68	740.52	987.37	1234.21	1481.05	1727.89	1974.73

Service factor	Motor current (x IFLC)	Trip time (s)							
		Class 5	Class 10	Class 15	Class 20	Class 25	Class 30	Class 35	Class 40
	1.30	No trip	No trip	No trip	No trip	No trip	No trip	No trip	No trip
1.35	7.20	6.35	12.70	19.06	25.41	31.76	38.11	44.47	50.82
	6.00	9.22	18.44	27.66	36.88	46.10	55.32	64.55	73.77
	5.00	13.43	26.87	40.30	53.74	67.17	80.61	94.04	107.48
	4.00	21.46	42.93	64.39	85.86	107.32	128.78	150.25	171.71
	3.00	40.16	80.32	120.48	160.64	200.80	240.97	281.13	321.29
	2.00	107.93	215.87	323.80	431.73	539.67	647.60	755.54	863.47
	1.50	294.76	589.52	884.28	1179.04	1473.80	1768.56	2063.32	2358.08
	1.35	No trip	No trip	No trip	No trip	No trip	No trip	No trip	No trip
1.40	7.20	6.84	13.68	20.52	27.36	34.20	41.04	47.89	54.73
	6.00	9.94	19.87	29.81	39.75	49.68	59.62	69.55	79.49
	5.00	14.49	28.98	43.47	57.96	72.45	86.95	101.44	115.93
	4.00	23.19	46.39	69.58	92.78	115.97	139.16	162.36	185.55
	3.00	43.59	87.19	130.78	174.38	217.97	261.56	305.16	348.75
	2.00	119.51	239.02	358.53	478.04	597.55	717.06	836.58	956.09
	1.50	363.64	727.28	1090.92	1454.56	1818.19	2181.83	2545.47	2909.11
	1.40	No trip	No trip	No trip	No trip	No trip	No trip	No trip	No trip
1.45	7.20	7.35	14.70	22.05	29.39	36.74	44.09	51.44	58.79
	6.00	10.68	21.36	32.04	42.72	53.40	64.08	74.77	85.45
	5.00	15.59	31.18	46.78	62.37	77.96	93.55	109.14	124.74
	4.00	25.00	50.01	75.01	100.02	125.02	150.03	175.03	200.04
	3.00	47.22	94.45	141.67	188.89	236.12	283.34	330.56	377.79
	2.00	132.36	264.73	397.09	529.45	661.82	794.18	926.54	1058.91
	1.50	483.63	967.26	1450.89	1934.52	2418.15	2901.78	3385.41	3869.04
	1.45	No trip	No trip	No trip	No trip	No trip	No trip	No trip	No trip
1.50	7.20	7.88	15.75	23.63	31.50	39.38	47.25	55.13	63.01
	6.00	11.45	22.91	34.36	45.82	57.27	68.73	80.18	91.64
	5.00	16.74	33.48	50.22	66.96	83.70	100.43	117.17	133.91
	4.00	26.90	53.80	80.69	107.59	134.49	161.39	188.29	215.19
	3.00	51.06	102.12	153.18	204.24	255.30	306.36	357.42	408.48
	2.00	146.73	293.45	440.18	586.90	733.63	880.35	1027.08	1173.81
	1.50	No trip	No trip	No trip	No trip	No trip	No trip	No trip	No trip

Parameter Settings

⚠ CAUTION
HAZARD OF MOTOR OVERHEATING
The Motor Trip Class parameter must be set to the thermal heating characteristics of the motor. Refer to the motor manufacturers instructions before setting this parameter.
Failure to follow these instructions can result in injury or equipment damage.

The **Thermal Overload Protection** function has the following configurable settings:

Parameter	Setting range	Default value
Function	<ul style="list-style-type: none"> • Alarm • Alarm + Trip • Trip • Disable 	Alarm + Trip
Service Factor	1.00–1.50 in step of 0.05	1.15
Trip Class	5, 10, 15, 20, 25, 30, 35, 40	10
Alarm Level	80–100% of thermal memory in step of 5%	80% TM
Reset Mode	<ul style="list-style-type: none"> • Reset key • DI • Communication • Auto 	Auto
Thermal Reset Level	30–95% of thermal memory in step of 5%	90% TM
Start Inhibit Level	5–100% of thermal memory in step of 5%	90% TM
Auxiliary Fan	<ul style="list-style-type: none"> • Disable • Enable 	Disable
Cool Down Function	<ul style="list-style-type: none"> • Disable • Enable 	Disable
Cool Down Time	0.0–6000.0 s in step of 0.1 s	0.0 s
Pause Function	<ul style="list-style-type: none"> • Disable • Enable 	Disable
Pause Time	0.0–6000.0 s in step of 0.1 s	0.0 s
Block Function	<ul style="list-style-type: none"> • Disable • Enable 	Disable
Block Level	80–95% of thermal memory in step of 5%	80%
Block Time	0.0–6000.0 s in step of 0.1 s	0.0 s

NOTE: When **Thermal Overload Protection** is disabled, the thermal memory will increase and thermal inhibit will appear.

Service Factor

Service factor of the motor is configurable from 1.00 to 1.50 as per the motor name plate.

Trip Class

Select the trip class as per the motor characteristics. The LTMT main unit provides **Thermal Overload Protection** for eight different trip classes – Class 5, Class 10, Class 15, Class 20, Class 25, Class 30, Class 35, Class 40.

Refer to Trip Time Chart, page 101 for selection of trip class and service factor.

Alarm Level

Alarm level of **Thermal Overload Protection** is configurable from 80% to 100% of thermal memory. The LTMT main unit generates the alarm signal once the thermal memory goes beyond the alarm level.

Thermal Reset Level

Thermal overload trip can be reset if the thermal memory goes below the **Thermal Reset Level**.

Start Inhibit Level

Start Inhibit Level is used to detect the thermal inhibit condition. If the thermal memory goes above the start inhibit level, the thermal inhibit cause is set.

NOTE: When the motor stops, thermal inhibit will appear.

Cool Down Function

Cool Down Function allows you to reset the thermal memory with configured cool down time.

If the **Cool Down Function** is enabled and motor is tripped due to thermal overload, thermal memory resets to zero after cool down time has elapsed.

Pause Function

The pause time is the specified cooling period for the motor after it trips under normal operating conditions (not during an overload trip).

After this period, TeSys Tera clears the thermal memory, allowing a new cold start. This enables multiple startups within a short time.

Block Function

Block Function allows you to block the **Thermal Overload Protection** for the configured block time during the motor start. This function blocks the thermal memory (TM) at the block level. For more information, refer to the below graphical representation.

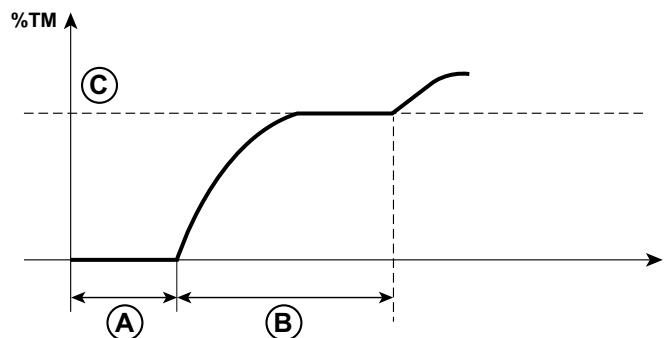

- A Motor stop
- B Block time
- C Block level

Auxiliary Fan

If the **Auxiliary Fan** is enabled, thermal memory will cool down four times faster. This mode is not suitable with cool down function and pause function.

Locked Rotor

Description

The **Locked Rotor** protection function protects the motor during the start of the motor. The **Locked Rotor** condition occurs mainly due to excessive load or due to improper connection between the rotor and the shaft. The **Locked Rotor** protection function is active only during the start time of the motor.

The **Locked Rotor** protection function generates the following signals:

- Alarm: Any of the three-phase currents of the motor goes above the alarm level during the start of the motor.
- Trip: Any of the three-phase currents of the motor goes above the trip level for the specified time delay during the start of the motor.

Parameter Setting

The locked rotor protection function has the following configurable settings:

Parameter	Setting range	Default value
Function	<ul style="list-style-type: none"> • Disable • Alarm • Trip • Alarm + Trip 	Trip
Trip Level	150–1000% of IFLC in step of 1%	200% of IFLC
Time Delay	0.1–6000.0 s in step of 0.1 s	10 s
Alarm Level	150–1000% of IFLC in step of 1%	200% of IFLC
Reset Mode	<ul style="list-style-type: none"> • Reset key • DI • Communication • Auto 	DI + Reset Key
Auto-Reset Delay (applicable only if Reset mode is Auto)	0.0–6000.0 s in step of 0.1 s	0 s

Stall Rotor

Description

The **Stall Rotor** condition occurs when the motor is in the Run state and occurs due to overload or the load jam. The **Stall Rotor** protection function is active only when the motor is in the Run state.

The **Stall Rotor** protection function generates the following signals:

- Alarm: Any of the three-phase currents of the motor goes above the alarm level during the motor Run state.
- Trip: Any of the three-phase currents of the motor goes above the pickup level for the specified time delay during the motor Run state.

Parameter Setting

The **Stall Rotor** protection function has the following configurable settings:

Parameter	Setting range	Default value
Function	<ul style="list-style-type: none"> • Disable • Alarm • Trip • Alarm + Trip 	Trip
Pickup	50–1000% of IFLC in step of 1%	200% of IFLC
Time Delay	0.1–6000.0 s in step of 0.1 s	2 s
Alarm Level	50–1000% of IFLC in step of 1%	200% of IFLC
Reset Mode	<ul style="list-style-type: none"> • Reset key • DI • Communication • Auto 	DI + Reset Key
Auto-Reset Delay (applicable only if Reset mode is Auto)	0.0–6000.0 s in step of 0.1 s	0 s

Temperature Protection

Description

The TeSys Tera system supports temperature inputs:

- One temperature input on LTMT main unit, that can be configured as PT100 or PTC.

The temperature protection function generates the following signals:

- Alarm: Temperature value goes above the alarm level.
- Trip: Temperature value goes above the trip level for the desired time delay.

LTMT Main Unit Parameter Setting

The temperature protection function of the LTMT main unit has the following configurable settings:

Parameter	Setting range	Default value
Function	<ul style="list-style-type: none"> • Disable • Alarm • Trip • Alarm + Trip 	Disable
PT100 trip level (applicable if PT100 sensor is selected)	25.0–180.0 °C in step of 0.1 °C	130.0 °C
PTC trip level (applicable if PTC sensor is selected)	2700–4000 Ω in step of 1 Ω	2700 Ω
PTC trip level reset (if PTC sensor is selected)	1600–2300 Ω in step of 1 Ω	1600 Ω
Time Delay	0.1–6000.0 s in step of 0.1 s	1 s
PT100 alarm level (applicable if PT100 sensor is selected)	25.0–180.0 °C in step of 0.1 °C	130.0 °C
Reset Mode	<ul style="list-style-type: none"> • Reset key • DI • Communication • Auto 	DI + Reset Key
Auto-Reset Delay (applicable only if Reset mode is Auto)	0.0–6000.0 s in step of 0.1 s	0 s

Current Protection Functions

What's in This Chapter

Definite Time Overcurrent	111
Normal Inverse Overcurrent	112
Short Time Overcurrent	113
Phase Under Current.....	115
Calculated Ground Trip.....	116
Measured Ground Trip.....	117
Current Imbalance.....	118
Current Phase Reversal.....	119
Current Phase Loss.....	120

Definite Time Overcurrent

Description

The TeSys Tera system provides the **Definite Time Overcurrent** protection when the motor is in the Start or Run state. There are two different configurable trip time delays, one for the motor start and another for the motor run state.

The **Definite Time Overcurrent** protection function generates the following signals:

- Alarm: Any of the three-phase currents of the motor goes above alarm level.
- Trip during the motor Start state: Any of the three-phase currents of the motor goes above the pickup level for the specified motor start time delay.
- Trip during the motor Run state: Any of the three-phase currents of the motor goes above the trip level for the specified motor run time delay.

Parameter Setting

The **Definite Time Overcurrent** protection function has the following configurable settings:

Parameter	Setting range	Default value
Function	<ul style="list-style-type: none"> • Disable • Alarm • Alarm + Trip • Trip 	Trip
Trip Level	20–1000% of IFLC in step of 1%	110% of IFLC
Time Delay During Motor Start (T_{ps})	0.1–6000.0 s in step of 0.1 s	30 s
Time Delay During Motor Run (T_{pr})	0.1–6000.0 s in step of 0.1 s	20 s
Alarm Level	20–1000% of IFLC in step of 1%	110% of IFLC
Reset Mode	<ul style="list-style-type: none"> • Reset key • DI • Communication • Auto 	DI + Reset Key
Auto-Reset Delay (applicable only if Reset mode is Auto)	0.0–6000.0 s in step of 0.1 s	0 s

Normal Inverse Overcurrent

Description

The TeSys Tera system provides the **Normal Inverse Overcurrent** (IEC class A – Standard inverse) protection function.

The trip time of the **Normal Inverse Overcurrent** protection is given by the formula:

$$T = TMS \left(\frac{k}{\left(\frac{I}{I_p}\right)^\alpha - 1} \right)$$

Where:

- T = Trip time
- TMS = Time multiplier
- k and α are the curve type constant. For standard inverse curve, k = 0.140 and $\alpha = 0.020$
- I = Actual current
- I_p = Pick up current setting

The **Normal Inverse Overcurrent** protection function generates the following signals:

- Alarm: Any of the three-phase currents of the motor goes above the alarm level.
- Trip: Any of the three-phase currents of the motor goes above the trip level for the time derived from IEC class A curve and time delay (TMS) setting.

Parameter Setting

The **Normal Inverse Overcurrent** protection function has the following configurable settings:

Parameter	Setting range	Default value
Function	<ul style="list-style-type: none"> • Disable • Alarm • Trip • Alarm + Trip 	Disable
Trip Level	20–1000% of IFLC in step of 1%	50% of IFLC
Time Delay (TMS)	0.1–20.0 s in step of 0.1 s	0.1 s
Alarm Level	20–1000% of IFLC in step of 1%	50% of IFLC
Reset Mode	<ul style="list-style-type: none"> • Reset key • DI • Communication • Auto 	DI + Reset Key
Auto-Reset Delay (applicable only if Reset mode is Auto)	0.0–6000.0 s in step of 0.1 s	0 s

Short Time Overcurrent

Description

The TeSys Tera system provides the definite time **Short Time Overcurrent** protection function.

The **Short Time Overcurrent** protection function generates the following signals:

- Alarm: Any of the three-phase currents of the motor goes above the alarm level.
- Trip: Any of the three-phase currents of the motor goes above the trip level for the specified time delay.

⚠ WARNING

UNINTENDED EQUIPMENT OPERATION

- Starter function do not stop the motor by de-energizing the contactor output on occurrence of **Short Time Overcurrent** trip.
- Configure the separate digital output for **Short Time Overcurrent** trip, to control circuit breaker.
- Common trip signal do not trip in case of **Short Time Overcurrent**.

Failure to follow these instructions can result in death, serious injury, or equipment damage.

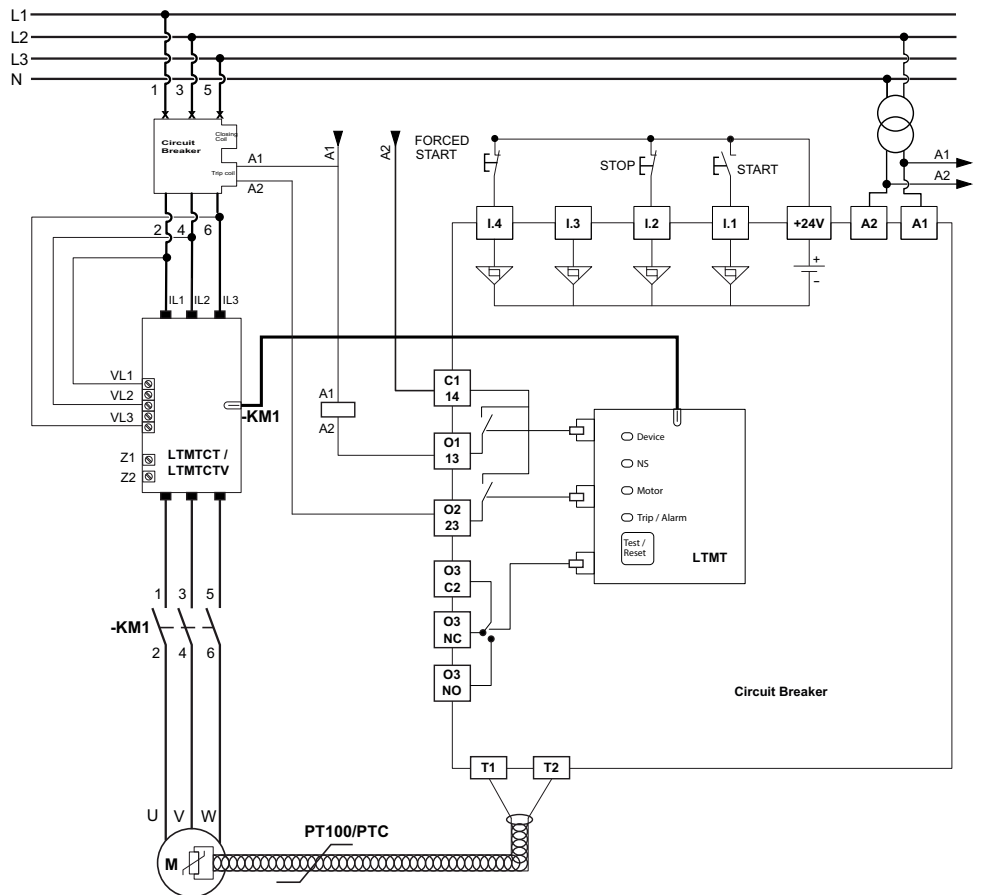

DO2 is configured as **Short Time Overcurrent**.

Parameter Setting

The **Short Time Overcurrent** protection function has the following configurable settings:

Parameter	Setting range	Default value
Function	<ul style="list-style-type: none"> • Disable • Alarm • Trip • Alarm + Trip 	Disable
Trip Level	100–1000% of IFLC in step of 1%	100% of IFLC
Time Delay	0.05–10.00 s in step of 0.01 s	0.05 s
Alarm Level	100–1000% of IFLC in step of 1%	100% of IFLC
Reset Mode	<ul style="list-style-type: none"> • Reset key • DI • Communication • Auto 	DI + Reset Key
Auto-Reset Delay (applicable only if Reset mode is Auto)	0.0–6000.0 s in step of 0.1 s	0 s

Phase Under Current

Description

The **Phase Under Current** condition generally occurs when motor is running with no load.

The **Phase Under Current** protection function generates the following signals:

- Alarm: Any of the three-phase currents of the motor goes below the alarm level.
- Trip: Any of the three-phase currents of the motor goes below the trip level for the specified time delay.

Parameter Setting

The **Phase Under Current** protection function has the following configurable settings:

Parameter	Setting range	Default value
Function	<ul style="list-style-type: none"> • Disable • Alarm • Trip • Alarm + Trip 	Alarm
Trip Level	15–100% of IFLC in step of 1%	50% of IFLC
Time Delay	0.1–6000.0 s in step of 0.1 s	10 s
Alarm Level	15–100% of IFLC in step of 1%	50% of IFLC
Reset Mode	<ul style="list-style-type: none"> • Reset key • DI • Communication • Auto 	Auto
Auto-Reset Delay (applicable only if Reset mode is Auto)	0.0–6000.0 s in step of 0.1 s	5 s

Calculated Ground Trip

Description

The ground current is an imbalanced current flowing through the neutral of the three-phase system. In normal conditions, the ground current is negligible or null. It is present only when a ground trip occurs.

DANGER

IMPROPER TRIP DETECTION

- **Calculated Ground Trip** protection function will not protect people from harm caused by ground current.
- **Calculated Ground Trip** pickup setting must be set to protect the motor and related equipment.
- **Calculated Ground Trip** settings must conform to national and local safety regulations and codes.

Failure to follow these instructions will result in death or serious injury.

The ground current is calculated internally by the LTMTCT/LTMTCTV sensor module. The **Calculated Ground Trip** protection function generates the following signals:

- Alarm: Calculated ground current goes above the alarm level.
- Trip: Calculated ground current goes above the trip level for the specified time delay.

The protection function can be disabled when the motor is in Start state, to avoid nuisance tripping.

It is recommended to use the following for **Calculated Ground Trip** protection:

- IFLC_{min} = 0.3 A in 0.3-3 A (similarly for 25 A and 100 A).
- Minimum ground trip threshold = 50% of 0.3 A = 0.15 A.

NOTE:

- If you keep protection setting below 50% of IFLC_{min}, then use measured ground trip with CBCT.
- **Calculated Ground Trip** protection is not applicable in single-phase mode.
- Hysteresis is not applicable for calculated ground current by setting less than 10% of FLC.

Parameter Setting

The **Calculated Ground Trip** protection function has the following configurable settings:

Parameter	Setting range	Default value
Function	<ul style="list-style-type: none"> • Disable • Alarm • Trip • Alarm + Trip 	Trip
Trip Level	10–500% of IFLC in step of 1%	20% of IFLC
Time Delay	0.05–600.00 s in step of 0.01 s	0.2 s
Alarm Level	10–500% of IFLC in step of 1%	20% of IFLC
Reset Mode	<ul style="list-style-type: none"> • Reset key • DI 	DI + Reset Key

Parameter	Setting range	Default value
	<ul style="list-style-type: none"> • Communication • Auto 	
Auto-Reset Delay (applicable only if Reset mode is Auto)	0–6000.0 s in step of 0.1 s	0.0 s
Function While Motor Starting	<ul style="list-style-type: none"> • Disable • Enable 	Disable

Measured Ground Trip

Description

Measured Ground Trip is more accurate than **Calculated Ground Trip**, it is calculated with the help of external core balanced current transformer. In normal conditions, the ground current is negligible or null. It is present only when a ground-trip occurs.

⚠️⚠️ DANGER

IMPROPER TRIP DETECTION

- Measured ground **Measured Ground Trip** protection function will not protect people from harm caused by ground current.
- **Measured Ground Trip** pickup setting must be set to protect the motor and related equipment.
- **Measured Ground Trip** settings must conform to national and local safety regulations and codes.

Failure to follow these instructions will result in death or serious injury.

The **Measured Ground Trip** protection function generates the following signals:

- Alarm: Measured ground current goes above the alarm level.
- Trip: Measured ground current goes above the trip level for the specified time delay.

The protection function can be disabled when the motor is in Start state, to avoid nuisance tripping.

NOTE: Hysteresis is not applicable for measured ground current by setting less than 10% of FLC.

Parameter Setting

The **Measured Ground Trip** protection function has the following configurable settings:

Parameter	Setting range	Default value
Function	<ul style="list-style-type: none"> • Disable • Alarm • Trip • Alarm + Trip 	Disable
Trip Level	20–20000 mA in step of 10 mA	30 mA
Time Delay	0.1–6000.0 s in step of 0.1 s	0.1 s
Alarm Level	20–20000 mA in step of 10 mA	30 mA
Reset Mode	<ul style="list-style-type: none"> • Reset key • DI 	DI + Reset Key

Parameter	Setting range	Default value
	<ul style="list-style-type: none"> • Communication • Auto 	
Auto-Reset Delay (applicable only if Reset mode is Auto)	0.0–6000.0 s in step of 0.1 s	0 s
Function While Motor Starting	<ul style="list-style-type: none"> • Disable • Enable 	Disable

Current Imbalance

Description

The **Current Imbalance** protection function generates the following signals:

- Alarm: **Current Imbalance** goes above the alarm level.
- Trip: **Current Imbalance** goes above the trip level for the specified time delay.

NOTE: **Current Imbalance** protection function is not applicable in single-phase mode.

Parameter Setting

⚠ CAUTION		
HAZARD OF MOTOR OVERHEATING		
<ul style="list-style-type: none"> • The Current Imbalance pickup setting must be properly set to protect the wiring and motor equipment from harm caused by motor overheating. • The setting you input must conform to national and local safety regulations and codes. • Refer to the motor manufacturer's instructions before setting this parameter. 		
Failure to follow these instructions can result in injury or equipment damage.		

The **Current Imbalance** protection function has the following configurable settings:

Parameter	Setting range	Default value
Function	<ul style="list-style-type: none"> • Disable • Alarm • Trip • Alarm + Trip 	Alarm + Trip
Trip Level	5–100% in step of 5%	20%
Time Delay	0.1–6000.0 s in step of 0.1 s	5 s
Alarm Level	5–100% in step of 5%	20%
Reset Mode	<ul style="list-style-type: none"> • Reset key • DI • Communication • Auto 	DI + Reset Key
Auto-Reset Delay (applicable only if Reset mode is Auto)	0.0–6000.0 s in step of 0.1 s	0 s

Current Phase Reversal

Description

The **Current Phase Reversal** protection function helps to identify the wrong wiring of three-phase motor.

The **Current Phase Reversal** protection function generates the following signals:

- Alarm: If the detected current phase sequence is not matching with the phase rotation setting , page 50.
- Trip: If the detected current phase sequence is not matching with the phase rotation setting, for the specified time delay.

NOTE: **Current Phase Reversal** is not applicable in single-phase mode.

Parameter Setting

The **Current Phase Reversal** protection function has the following configurable settings:

Parameter	Setting range	Default value
Function	<ul style="list-style-type: none"> • Disable • Alarm • Alarm + Trip • Trip 	Trip
Time Delay	0.1–6000.0 s in step of 0.1 s	0.1 s
Reset Mode	<ul style="list-style-type: none"> • Reset key • DI • Communication • Auto 	DI + Reset Key
Auto-Reset Delay (applicable only if Reset mode is Auto)	0.0–6000.0 s in step of 0.1 s	0 s

Current Phase Loss

Description

The **Current Phase Loss** protection function generates the following signals:

- Alarm: Any of the three-phase currents of the motor goes below 10% of the motor full load current.
- Trip: Any of the three-phase currents of the motor goes below 10% of the motor full load current for the specified time delay.

NOTE:

1. **Current Phase Loss** protection function is not applicable in single-phase mode.
2. Current values that are less than 10% of FLC are considered as stop, and no value is displayed in metering and trip logs.

Parameter Setting

The **Current Phase Loss** protection function has the following configurable settings:

Parameter	Setting range	Default value
Function	<ul style="list-style-type: none"> • Disable • Alarm • Trip • Alarm + Trip 	Trip
Time Delay	0.1–6000.0 s in step of 0.1 s	0.1 s
Reset Mode	<ul style="list-style-type: none"> • Reset key • DI • Communication • Auto 	DI + Reset Key
Auto-Reset Delay (applicable only if Reset mode is Auto)	0.0–6000.0 s in step of 0.1 s	0 s

Voltage Protection Functions

What's in This Chapter

Phase Under Voltage.....	122
Phase Over Voltage.....	123
Voltage Imbalance.....	124
Voltage Phase Reversal.....	125
Voltage Phase Loss.....	126

Phase Under Voltage

Description

The phase under voltage protection function generates the following signals:

- Alarm: Any of the line-to-line voltage goes below the alarm level.
- Trip: Any of the line-to-line voltage goes below the trip level for the specified time delay.

NOTE: This function enables after 500 ms once the voltage is detected.

Parameter Setting

The phase under voltage protection function has the following configurable settings:

Parameter	Setting range	Default value
Function	<ul style="list-style-type: none"> • Disable • Alarm • Trip • Alarm + Trip 	Trip
Trip Level	20–100% of nominal voltage in step of 1%	80% of nominal voltage
Time Delay	0.1–6000.0 s in step of 0.1 s	10 s
Alarm Level	20–100% of nominal voltage in step of 1%	80% of nominal voltage
Reset Mode	<ul style="list-style-type: none"> • Reset key • DI • Communication • Auto 	Auto
Auto-Reset Delay (applicable only if Reset mode is Auto)	0.0–6000.0 s in step of 0.1 s	0 s

Phase Over Voltage

Description

The phase over voltage protection function generates the following signals:

- Alarm: Any of the line-to-line voltage goes above the alarm level.
- Trip: Any of the line-to-line voltage goes above the trip level for the specified time delay.

Parameter Setting

The phase over voltage protection function has the following configurable settings:

Parameter	Setting range	Default value
Function	<ul style="list-style-type: none"> • Disable • Alarm • Trip • Alarm + Trip 	Trip
Trip Level	101–130% of nominal voltage in step of 1%	110% of nominal voltage
Time Delay	0.1–6000.0 s in step of 0.1 s	5 s
Alarm Level	101–130% of nominal voltage in step of 1%	110% of nominal voltage
Reset Mode	<ul style="list-style-type: none"> • Reset key • DI • Communication • Auto 	DI + Reset Key
Auto-Reset Delay (applicable only if Reset mode is Auto)	0.0–6000.0 s in step of 0.1 s	0 s

Voltage Imbalance

Description

The voltage imbalance protection function generates the following signals:

- Alarm: Voltage imbalance goes above the alarm level.
- Trip: Voltage imbalance goes above the trip level for the specified time delay.

NOTE: Voltage imbalance is not applicable in single-phase mode.

Parameter Setting

The voltage imbalance protection function has the following configurable settings:

Parameter	Setting range	Default value
Function	<ul style="list-style-type: none"> • Disable • Alarm • Trip • Alarm + Trip 	Alarm + Trip
Trip Level	5–50% of nominal voltage in step of 5%	10% of nominal voltage
Time Delay	0.1–6000.0 s in step of 0.1 s	10 s
Alarm Level	5–50% of nominal voltage in step of 5%	10% of nominal voltage
Reset Mode	<ul style="list-style-type: none"> • Reset key • DI • Communication • Auto 	DI + Reset Key
Auto-Reset Delay (applicable only if Reset mode is Auto)	0.0–6000.0 s in step of 0.1 s	0 s

Voltage Phase Reversal

Description

The voltage phase reversal protection function helps to identify the wrong wiring of three-phase voltage.

The voltage phase reversal protection function generates the following signals:

- Alarm: If the detected voltage phase sequence is not matching with the phase rotation setting , page 50.
- Trip: If the detected voltage phase sequence is not matching with the phase rotation setting, for the specified time delay.

NOTE: Voltage phase reversal is not applicable in single-phase mode.

Parameter Setting

The voltage phase reversal protection function has the following configurable settings:

Parameter	Setting range	Default value
Function	<ul style="list-style-type: none"> • Disable • Alarm • Trip • Alarm + Trip 	Trip
Time Delay	0.1–6000.0 s in step of 0.1 s	0.1 s
Reset Mode	<ul style="list-style-type: none"> • Reset key • DI • Communication • Auto 	DI + Reset Key
Auto-Reset Delay (applicable only if Reset mode is Auto)	0.0–6000.0 s in step of 0.1 s	0 s

Voltage Phase Loss

Description

The voltage phase loss trip is activated, when one of the voltage phase is lost.

The voltage phase loss protection function generates the following signals:

- Alarm: Voltage imbalance goes above 38%.
- Trip: Voltage imbalance goes above 38% for the specified time delay.

Voltage phase loss is not applicable in single-phase mode.

Parameter Setting

The voltage phase loss protection function has the following configurable settings:

Parameter	Setting range	Default value
Function	<ul style="list-style-type: none"> • Disable • Alarm • Trip • Alarm + Trip 	Trip
Time Delay	0.1–6000.0 s in step of 0.1 s	0.1 s
Reset Mode	<ul style="list-style-type: none"> • Reset key • DI • Communication • Auto 	DI + Reset Key
Auto-Reset Delay (applicable only if Reset mode is Auto)	0.0–6000.0 s in step of 0.1 s	0 s

Power Protection Functions

What's in This Chapter

Over Frequency	128
Under Frequency	129
Over Power.....	130
Under Power.....	131
Under Power Factor	132

Over Frequency

Description

The **Over Frequency** protection function generates the following signals:

- Alarm: Measured frequency goes above the alarm level.
- Trip: Measured frequency goes above the trip level for the specified time delay.

Parameter Setting

The **Over Frequency** protection function has the following configurable settings:

Parameter	Setting range	Default value
Function	<ul style="list-style-type: none"> • Disable • Alarm • Trip • Alarm + Trip 	Disable
Trip Level	100–110% of nominal frequency in step of 1%	105% of nominal frequency
Time Delay	0.1–6000.0 s in step of 0.1 s	0.1 s
Alarm Level	100–110% of nominal frequency in step of 1%	105% of nominal frequency
Reset Mode	<ul style="list-style-type: none"> • Reset key • DI • Communication • Auto 	DI + Reset Key
Auto-Reset Delay (applicable only if Reset mode is Auto)	0.0–6000.0 s in step of 0.1 s	0 s

Under Frequency

Description

The **Under Frequency** protection function generates the following signals:

- Alarm: Measured frequency goes below the alarm level.
- Trip: Measured frequency goes below the trip level for the specified time delay.

NOTE: This function enables after 500 ms once the voltage is detected.

Parameter Setting

The **Under Frequency** protection function has the following configurable settings:

Parameter	Setting range	Default value
Function	<ul style="list-style-type: none"> • Disable • Alarm • Trip • Alarm + Trip 	Disable
Trip Level	90–100% of nominal frequency in step of 1%	94% of nominal frequency
Time Delay	0.1–6000.0 s in step of 0.1 s	0.1 s
Alarm Level	90–100% of nominal frequency in step of 1%	94% of nominal frequency
Reset Mode	<ul style="list-style-type: none"> • Reset key • DI • Communication • Auto 	DI + Reset Key
Auto-Reset Delay (applicable only if Reset mode is Auto)	0.0–6000.0 s in step of 0.1 s	0 s

Over Power

Description

The **Over Power** protection function generates the following signals:

- Alarm: Measured active power goes above the alarm level.
- Trip: Measured active power goes above the trip level for the specified time delay.

Parameter Setting

The **Over Power** protection function has the following configurable settings:

Parameter	Setting range	Default value
Function	<ul style="list-style-type: none"> • Disable • Alarm • Trip • Alarm + Trip 	Disable
Trip Level	20–1000% of nominal power in step of 1%	110% of nominal power
Time Delay	0.1–6000.0 s in step of 0.1 s	0.1 s
Alarm Level	20–1000% of nominal power in step of 1%	110% of nominal power
Reset Mode	<ul style="list-style-type: none"> • Reset key • DI • Communication • Auto 	DI + Reset Key
Auto-Reset Delay (applicable only if Reset mode is Auto)	0.0–6000.0 s in step of 0.1 s	0 s

Under Power

Description

The **Under Power** protection function generates the following signals:

- Alarm: The measured active power goes below the alarm level.
- Trip: The measured active power goes below the trip level for the specified time delay.

NOTE: This function enables after 500 ms once the voltage is detected.

Parameter Setting

The **Under Power** protection function has the following configurable settings:

Parameter	Setting range	Default value
Function	<ul style="list-style-type: none"> • Disable • Alarm • Trip • Alarm + Trip 	Disable
Trip Level	20–1000% of nominal power in step of 1%	60% of nominal power
Time Delay	0.1–6000.0 s in step of 0.1 s	0.1 s
Alarm Level	20–1000% of nominal power in step of 1%	60% of nominal power
Reset Mode	<ul style="list-style-type: none"> • Reset key • DI • Communication • Auto 	DI + Reset Key
Auto-Reset Delay (applicable only if Reset mode is Auto)	0.0–6000.0 s in step of 0.1 s	0.0 s

Under Power Factor

Description

The **Under Power Factor** protection function generates the following signals:

- Alarm: Power factor ($\cos \phi$) goes below the alarm level.
- Trip: Power factor ($\cos \phi$) goes below the trip level for the specified time delay.

NOTE: This function enables after 500 ms once the voltage is detected.

Parameter Setting

The **Under Power Factor** protection function has the following configurable settings:

Parameter	Setting range	Default value
Function	<ul style="list-style-type: none"> • Disable • Alarm • Trip • Alarm + Trip 	Disable
Trip Level	0.40–1.00 in step of 0.01	0.6 PF
Time Delay	0.1–6000.0 s in step of 0.1 s	0.1 s
Alarm Level	0.40–1.00 in step of 0.01	0.6 PF
Reset Mode	<ul style="list-style-type: none"> • Reset key • DI • Communication • Auto 	DI + Reset Key
Auto-Reset Delay (applicable only if Reset mode is Auto)	0.0–6000.0 s in step of 0.1 s	0 s

Digital Input Interlock

Description

Any digital input of LTMT main unit or LTMT expansion module can be configured as interlock, helps to prevent start of motor in absence of required digital inputs. Similarly, the respective **Interlock Protection**, if enabled, trips the motor in the absence of interlock. Maximum of 12 digital inputs can be used as interlock (1-12) and each interlock is provided with the protection function.

The interlock input can be assigned as a function such as alarm or trip which will be performed on the absence of that interlock. The interlock configured as trip causes the LTMT main unit to trip in the event of absence of the corresponding interlock.

The digital input **Interlock Protection** function generates the following signals:

- Alarm: When digital input interlock status is in the low state.
- Trip: When digital input interlock status is in the low state for the specified time delay.

Parameter Setting

Each digital input **Interlock Protection** function has the following configurable settings:

Parameter	Setting range	Default value
Function	<ul style="list-style-type: none"> • Disable • Alarm • Trip • Alarm + Trip 	Disable
Time Delay	0.1–6000.0 s in step of 0.1 s	0 s
Reset Mode	<ul style="list-style-type: none"> • Reset key • DI • Communication • Auto 	DI + Reset Key
Auto-Reset Delay (applicable only if Reset mode is Auto)	0.0–6000.0 s in step of 0.1 s	0 s

Analog Input Protection

Description

There are maximum four analog inputs possible with maximum of two LTMTAN21 expansion modules. For each LTMT expansion module, the analog input (AI) are provided with protection function.

The **AI Protection** function generates the following signals:

- Alarm:
 - For detection setting Under, if the analog input goes below the alarm level
 - For detection setting Over, if the analog input goes above the alarm level
- Trip:
 - For detection setting Under, if the analog input goes below the trip level for the desired time delay
 - For detection setting Over, if the analog input goes above the trip level for the desired time delay

Parameter Setting

Each **AI Protection** function has the following configurable settings:

Parameter	Setting range	Default value
Function	<ul style="list-style-type: none"> • Disable • Alarm • Trip • Alarm + Trip 	Disable
Detection	<ul style="list-style-type: none"> • Under • Over 	Under
Trip level	4.0–20.0 mA in step of 0.1 mA	4.0 mA
Time delay	0.0–6000.0 s in step of 0.1 s	0.0 s
Alarm	4.0–20.0 mA in step of 0.1 mA	4.0 mA
Reset mode	<ul style="list-style-type: none"> • Auto • DI • Communication • Reset Key 	DI + Reset Key
Auto Reset Delay (applicable only if Reset mode is Auto)	0.0–6000.0 s in step of 0.1 s	0.0 s
Diagnostic	<ul style="list-style-type: none"> • Disable • Enable 	Disable

AO Settings

Description

The TeSys Tera system supports up to two analog outputs (AO) with two LTMTAN21 expansion modules.

Parameter Setting

Each **AO Settings** function has the following configurable settings:

Parameter	Setting range	Default value
AO1 Source	<ul style="list-style-type: none"> • None • L1 RMS Current • L2 RMS Current • L3 RMS Current • Average Current • L1-L2 RMS Voltage • L2-L3 RMS Voltage • L3-L1 RMS Voltage • Average Voltage • System Frequency • Total Active Power • Total Apparent Power 	None

Analog Output Source Settings

The table lists the minimum and maximum setting values for each analog output source.

Analog Output source	Default Value	AO1 source minimum range	AO1 source maximum range
None	None	0	0
L1 RMS current	10 %FLC1	10 %FLC1	1000 %FLC1
L2 RMS current	10 %FLC1	10 %FLC1	1000 %FLC1
L3 RMS current	10 %FLC1	10 %FLC1	1000 %FLC1
Average current	10 %FLC1	10 %FLC1	1000 %FLC1
L1-L2 RMS voltage	20 %Vn	20 %Vn	150 %Vn
L2-L3 RMS voltage	20 %Vn	20 %Vn	150 %Vn
L3-L1 RMS voltage	20 %Vn	20 %Vn	150 %Vn
Average voltage	20 %Vn	20 %Vn	150 %Vn
System frequency	50 %NominalHz	50 %NominalHz	150 %NominalHz
Total active power	20 %Pn	20 %Pn	1000 %Pn
Total apparent power	20 %Pn	20 %Pn	1000 %Pn

Motor Control Functions

What's in This Part

Motor Control Station.....	137
Motor Starter Functions	153
Motor Control Function	169

Motor Control Station

What's in This Chapter

Overview	138
Working Principle of the Motor Starters	138
Motor Starter Settings	140
Operating Modes.....	146
Digital Inputs.....	148
Digital Outputs	151

Overview

The TeSys Tera system provides the motor starter functions that helps to reduce the wiring and external components like starters or timers. With the TeSys Tera system motor starter functions, the motor can be directly controlled through the contactors.

Working Principle of the Motor Starters

⚠ WARNING
<p>UNINTENDED EQUIPMENT OPERATION</p> <ul style="list-style-type: none"> • The application of this product requires expertise in the design and programming of control systems. Only personnel with such expertise should be allowed to program, install, configure, alter and apply this product. Follow all local and national safety codes and standards. • Change in Load type or Starter type can cause short circuit or turn on power supply to the load. • Check if appropriate wiring is done according to the Load type or Starter type. • Make sure that the motor power supply is cut off while changing the starter settings, digital input settings, and digital output settings. <p>Failure to follow these instructions can result in death, serious injury, or equipment damage.</p>

Based on the application requirements, different types of motor starters are used to switch the motor on or off. There are different types of motors with different wiring connections available for controlling the motor as per the application. The TeSys Tera system provides option to choose the right motor starters to control the motor for different types of application.

The following diagram shows the block diagram of TeSys Tera motor starter.

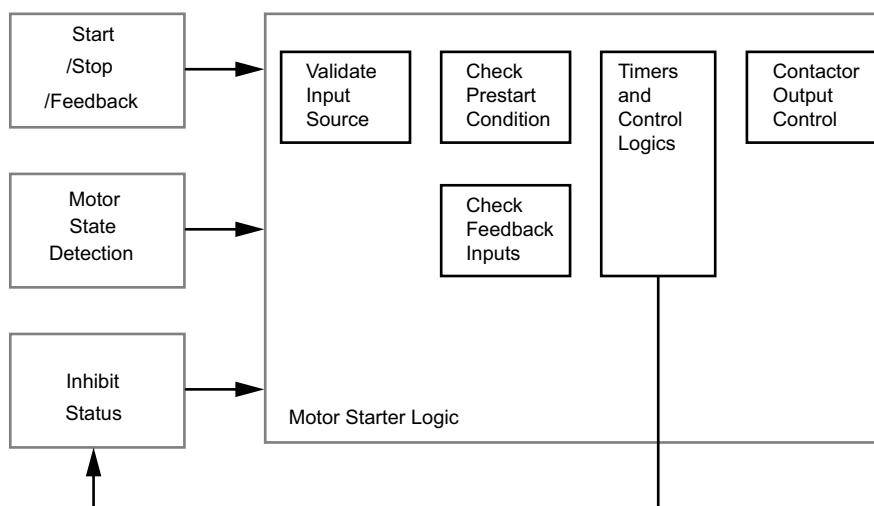

Once the Start or Stop input command is received, the motor starter logic validates the input source. Based on the selected operating mode, the Start or Stop command is performed. The motor starter logic checks the pre-start conditions (inhibit status and motor status). Depending on the selected starter type, the motor starter logic runs the control logics and updates the contactor control output and the inhibit status.

The inputs and outputs of the motor starter logic are user configurable. The TeSys Tera system allows you to customize the motor starter logic by addition of custom logics before or/and after the motor starter logic. See the following block diagram for example.

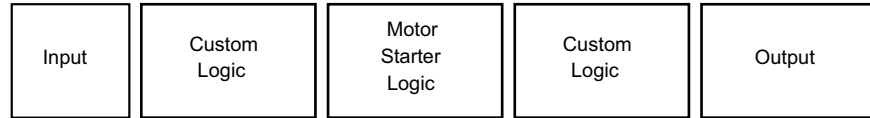

For more information on the custom logic editor, refer to the *TeSys Tera Motor Management System DTM Library Online Help Guide – DOCA0275EN*.

Motor Starter Settings

TeSys Tera system supports most of the starter logics with the inbuilt starter logics and external inputs (start, stop, feedback, and so on) and switches the motor on or off with external contactors.

Motor start and stop is possible from LTMTCUF control operator unit (HMI), DI (Local or remote DI), and communication (PLC or DCS). Motor starter logics also consider the feedback, such as, the contactor open or close status, and motor current to control the contactor. As per the starter selected, the required CONTACTOR_OUTPUT will be used for contactor control.

Parameter Settings

⚠ WARNING

UNINTENDED EQUIPMENT OPERATION

The application of this product requires expertise in the design and programming of control systems. Only personnel with such expertise should be allowed to program, install, configure, alter and apply this product. Follow all local and national safety codes and standards.

Failure to follow these instructions can result in death, serious injury, or equipment damage.

The motor starter settings can be set up using following interfaces:

- A PC running the TeSys Tera DTM embedded in a FDT container such as SoMove software.
- The LTMTCUF control operator unit.
- A PLC or DCS through the communication network.

Parameter	Setting range	Default value
Starter Type	<ul style="list-style-type: none"> • Direct Online • Reverse Direct Online • Star-Delta • Overload • Custom logic 256 to Custom logic 511 	Direct Online
Mode Selection	<ul style="list-style-type: none"> • Disable • HMI • DI • Communication 	Disable
Local 1 Start	<ul style="list-style-type: none"> • None • Selection of a combination of the 5 control sources: HMI, Local DI, Remote DI, Communication, and Custom logic 	Communication + Local DI + HMI
Local 2 Start	<ul style="list-style-type: none"> • None • Selection of a combination of the 5 control sources: HMI, Local DI, Remote DI, Communication, and Custom logic 	None
Local 3 Start	<ul style="list-style-type: none"> • None 	None

	<ul style="list-style-type: none"> Selection of a combination of the 5 control sources: HMI, Local DI, Remote DI, Communication, and Custom logic 	
Remote Start	<ul style="list-style-type: none"> None Selection of a combination of the 5 control sources: HMI, Local DI, Remote DI, Communication, and Custom logic 	None
Local 1 Stop	<ul style="list-style-type: none"> None Selection of a combination of the 5 control sources: HMI, Local DI, Remote DI, Communication, and Custom logic 	Communication + Local DI + HMI
Local 2 Stop	<ul style="list-style-type: none"> None Selection of a combination of the 5 control sources: HMI, Local DI, Remote DI, Communication, and Custom logic 	None
Local 3 Stop	<ul style="list-style-type: none"> None Selection of a combination of the 5 control sources: HMI, Local DI, Remote DI, Communication, and Custom logic 	None
Remote Stop	<ul style="list-style-type: none"> None Selection of a combination of the 5 control sources: HMI, Local DI, Remote DI, Communication, and Custom logic 	None
Local DI Start Input	<ul style="list-style-type: none"> Momentary Maintained 	Momentary
Remote DI Start Input	<ul style="list-style-type: none"> Momentary Maintained 	Momentary
Custom Start Input	<ul style="list-style-type: none"> Momentary Maintained 	Momentary
Mode Transfer	<ul style="list-style-type: none"> Bump Bumpless 	Bump
Communication Start Input	<ul style="list-style-type: none"> Momentary Maintained 	Momentary
Change Direction	<ul style="list-style-type: none"> Disable Enable 	Disable
Interlocking Time ⁽¹³⁾	0.01 to 600.00 s in step of 0.01 s	60.00 s
Feedback Response Time	0.01 to 600.00 s in step of 0.01 s	0.5 s
Current Sensing Time	0.01 to 600.00 s in step of 0.01 s	0.5 s
Time in Star	0.01 to 600.00 s in step of 0.01 s	10 s
Change Over Time	0.01 to 600.00 s in step of 0.01 s	0.3 s

⁽¹³⁾ For the proper functioning of this functionality, the settings of the interlocking time must be greater than the contactor opening time of the system connected.

Stop Detection	<ul style="list-style-type: none"> • Current based • DI + Current based 	Current Based
Forced Start Function	<ul style="list-style-type: none"> • Disable • Enable 	Disable

Local and Remote Start Input Type

The Local DI Start Input parameter defines the type of command provided by the digital inputs used to start and stop the motor in Local 1, Local 2, or Local 3 operating mode.

The start switch input from the drawer or panel can be configured as Local start DI.

The Remote DI Start Input parameter defines the type of command provided by the digital inputs used to start and stop the motor in Remote operating mode.

The start input from control panel can be configured as Remote start DI.

Both parameters can be set separately to:

- Momentary (default value): Two digital inputs are required to deliver the start and stop commands of the motor:
 - One digital input for the Start command, triggered by a rising edge (if the input type is set as active high) or a falling edge (if the input type is set as active low) on the Start digital inputs as per the selected motor starter type.
 - One digital input for the Stop command, triggered by a rising edge (if the input type is set as active high) or a falling edge (if the input type is set as active low) on the Stop digital inputs as per the selected motor starter type.
- Maintained: Only one digital input is required to deliver the start and stop commands of the motor. Only digital inputs for the Start commands must be assigned as per the selected motor starter type. It is not required to assign a digital input to the Stop command. Input selected in maintained mode will function as a single input, no stop input has to be supplied. If the input is high, the motor will start and if it is low, the motor will stop.

Custom Start Input Type

You can use existing or create a custom logic program to customize DI and DO for motor start and stop. The parameter can be set to:

- Momentary (default value): Two custom inputs are required to deliver the start and stop commands of the motor.
- Maintained: Only one custom input is required to deliver the start and stop commands of the motor. Only custom inputs for Start commands must be programmed as per the selected motor starter type. It is not required to program a custom input for the Stop command.

Communication Start Input Type

Communication start input type defines the behavior of start and stop command from PLC or DCS. The parameter can be set to:

- Momentary (default value): Separate start and stop commands from different registers are required from PLC or DCS.
- Maintained: Only one register command is required from PLC or DCS to start or stop the motor.

NOTE: If the motor start command is received from a momentary source, send the stop command from the same source. If the start command is received from a maintained source, send the stop command from the same source.

Feedback Timeout Detection

Feedback timeout detection function is used to check if the motor starts after activation of the RUN output. After activation of the RUN output, feedback timeout is detected if:

- The motor current is not detected ($IMAX < 10\% IFLC$) within the configured motor current sensing time.
- The motor stop detection is configured as DI+IFLC, and if the status of the digital input assigned to the optional RUN DI has not changed within the configured feedback response time.

Feedback timeout detection is a stop cause of motor starters.

Feedback Response Time

This time is used by feedback timeout function, to stop the motor by deactivating RUN (CONTACTOR OUTPUT), in case of no detection of RUN DI (Contactor feedback signal when it is command to close) within configured feedback response time.

NOTE: Configure Stop detection setting as Current based+DI and one of the Digital input as RUN DI to enable the feedback response time functionality.

Current Sensing Time

This time is used by feedback timeout function, to stop the motor by deactivating RUN (CONTACTOR OUTPUT), in case of no detection of motor current within configured current sensing time.

Auto-Stop Detection

Auto-stop detection function is used to detect that the motor has stopped while the RUN output is still activated.

You can select the auto-stop detection mode:

- Current based: Auto-stop detected if motor current $IMAX < 5\% IFLC$.
- Current based + DI (default value):
 - If RUN DI (Contactor feedback) is configured: Auto stop is detected only if RUN DI indicates that the contactor is open.
 - If RUN DI is not configured: Auto stop is detected if motor current $IMAX < 5\% IFLC$.

Auto-stop detection is a stop cause of motor starters. On detection of Auto-stop, TeSys Tera motor starter logic deactivates the RUN (CONTACTOR OUTPUT).

RUN DI Assignment

The feedback timeout and the auto-stop detection can use a digital input assigned to RUN DI to get the feedback of the contactor.

The contactor contacts to wire in parallel to the digital input assigned to RUN DI depends on the motor starter type:

- Direct Online: KM1
- Reversible Direct Online: KM1 and KM2
- Star-Delta: KM1 (no detection of the KM2 and KM3 feedback)

NOTE: TeSys Tera system only supports one feedback (RUN DI), the feedback signals from other contactors must be connected parallel to one (RUN DI) using the appropriate external interlocks for starts other than direct online starters.

Transfer Mode

In Bump mode, if you change the mode when motor is running, then the motor will stop. For example, if you change mode from Local 1 to Remote, motor will stop.

In Bumpless mode, the motor operation remains uninterrupted even after the mode is changed.

Change Direction

The change direction logic is applicable to the Reverse Direct Online starter type.

TeSys Tera system can change direction from forward to reverse and reverse to forward according to one of two logics:

- Logic with Change direction parameter set to Enable. This logic does not require a Stop command.
 - If a Reverse Start command from a valid source is received while the motor is running forward, TeSys Tera system deactivates the forward contactor and starts the Interlock timer. Once the Interlock timer is elapsed, the TeSys Tera system activates the reverse contactor.
 - If a Forward Start command from a valid source is received while the motor is running reverse, TeSys Tera system deactivates the reverse contactor and starts the Interlock timer. Once the Interlock timer is elapsed, the TeSys Tera system activates the forward contactor.

NOTE:

- The settings of the interlocking time must be greater than the contactor opening time of the system connected.
- The following settings are disabled when Direction Change Inhibit is turned ON:
 - **Device Configuration**
 - **System Setting**
 - **Starter Setting**
 - **Communication Setting**
 - **DI Setting**
 - **DO Setting**
 - **Name Plate**
 - **AO Settings**
 - **Device Session Management**

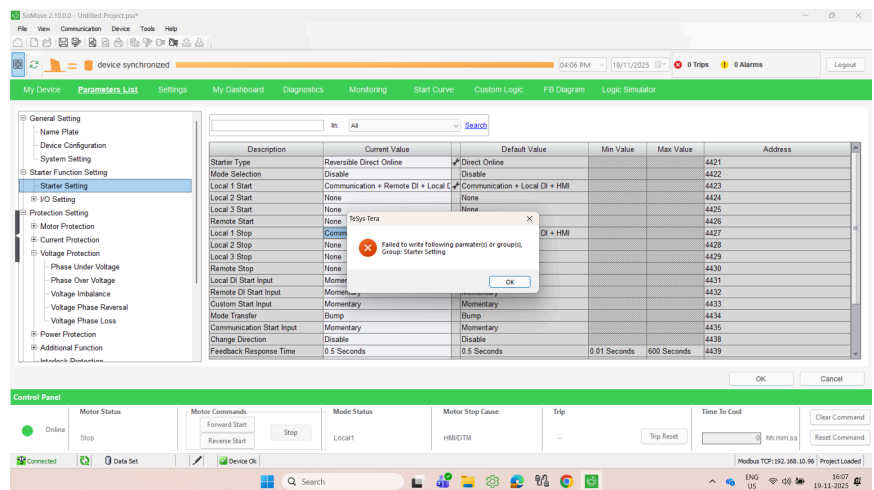

- Logic with Change direction parameter set to Disable. This logic requires a Stop command from a valid source as per the selected operating mode, Operating Modes, page 146. The Stop command starts the Interlock timer. Once the Interlock timer is elapsed, the motor can be started by a Start command in another direction.

Changeover Time

The changeover time is applicable to the Star-Delta starter types.

In Star-Delta, the changeover time is used to switch from Star to Delta connection. After the time in Star has elapsed, the TeSys Tera starter logic deactivates the Star CONTACTOR OUTPUT and waits for the changeover time to elapse. Once the changeover time has elapsed, the TeSys Tera starter logic activates the Delta CONTACTOR OUTPUT.

Operating Modes

You can configure the motor control source for four operating modes:

- Local 1 (L1)
- Local 2 (L2)
- Local 3 (L3)
- Remote (R)

TeSys Tera system allows motor Start or Stop commands from the following control sources:

- **HMI:** Start or Stop commands from the LTMTCUF control operator unit or TeSys Tera DTM.
- **Local DI (L-Start/L-Stop):** Start or Stop commands from a local control panel near to the motor, connected to TeSys Tera digital inputs.
- **Remote DI (R-Start/R-Stop):** Start or Stop commands from a remote control panel, connected to TeSys Tera digital inputs.
- **Communication:** Start or Stop commands from a PLC or DCS through the communication network.
- **Custom:** Start or Stop commands from the custom logic.

The following table shows an example of selection of motor control source for different operating modes.

Motor control	Operating modes	Motor control source				
		HMI	Local DI	Remote DI	Communication	Custom
Start	Local 1	✓	✓	✓	✓	✓
	Local 2	✓	✓	✓	✓	✓
	Local 3	✓	✓	✓	✓	✓
	Remote	✓	✓	✓	✓	✓
Stop	Local 1	✓	✓	✓	✓	✓
	Local 2	✓	✓	✓	✓	✓
	Local 3	✓	✓	✓	✓	✓
	Remote	✓	✓	✓	✓	✓

Operating Mode Selection

Only one operating mode is activated at a time.

The active operating mode can be selected through HMI, digital inputs or communication, based on the mode selection setting.

NOTE: If the **Mode Selection** setting is **Disable**, Local 1 operating mode is selected.

Operating Mode Selection Through HMI

If the mode selection setting is **HMI**, then the selection of Local 1, Local 2, Local 3 and Remote operating mode can be done from LTMTCUF control operator unit. You can select the required operating mode from the control unit by pressing the **Local/Remote** key while the **Home** screen is displayed. Once the operating mode is selected from the control unit, the mode will remain the same until you changes it to other mode.

Operating Mode Selection Through Digital Inputs

If the mode selection setting is **DI**, then the operating mode is selected through the digital inputs assigned to **Mode Selection 1** and/or **Mode Selection 2**. You can configure minimum one DI in DI setting using the TeSys Tera DTM.

The following mode selection combinations are possible through DI:

- Only one DI is assigned to **Mode Selection 1** in DI settings:

Operating mode	Mode Selection 1 DI
Local 1	OFF
Remote	ON

- Only one DI is assigned to **Mode Selection 2** in DI settings:

Operating mode	Mode Selection 2 DI
Local 1	OFF
Local 2	ON

- Two DI are assigned to **Mode Selection 1** and **Mode Selection 2** in DI settings:

Operating mode	Mode Selection 1 DI	Mode Selection 2 DI
Local 1	OFF	OFF
Remote	ON	OFF
Local 2	OFF	ON
Local 3	ON	ON

Operating Mode Selection Through Communication

If the mode selection setting is **Communication**, then the operating mode is selected by setting the Operating mode selection bits accordingly. For more information, refer to the appropriate TeSys Tera communication guide , page 11.

Operating mode	Mode Selection 1 Bit	Mode Selection 2 Bit
Local 1	0	0
Remote	1	0
Local 2	0	1
Local 3	1	1

Digital Inputs

⚠ WARNING
<p>UNINTENDED MACHINE OPERATION</p> <ul style="list-style-type: none"> • Change in DI settings can cause short circuit or turn on power supply to the load. • Check if appropriate wiring is done according to the DI settings. • Ensure that the three-phase power supply is cut off while changing the DI settings. <p>Failure to follow these instructions can result in death, serious injury, or equipment damage.</p>

The TeSys Tera system supports maximum of 24 digital inputs:

- Four digital inputs on LTMT main units.
- Up to 20 digital inputs with LTMT expansion modules.

Input Configuration

The configuration of the digital inputs can be made through one of the following interfaces:

- A PC running the TeSys Tera DTM embedded in a FDT container such as SoMove software.
- The LTMTCUF control operator unit.
- A PLC or DCS through the communication network.

Each digital input has the following parameters:

Parameter	Setting range
Trigger type	<ul style="list-style-type: none"> • Active high • Active low
Validation time	0 to 60000 ms in step of 10 ms
Input source	See list in input assignment

The digital inputs are set by default depending on the motor starter type selected.

Input Type

The Active type and Validation time (t) parameters defines how the physical information connected to the input (A) is converted in the digital input information (B) processed by the LTMT main unit.

Active High Inputs

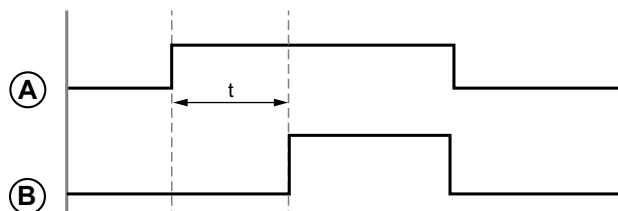

Active Low Inputs

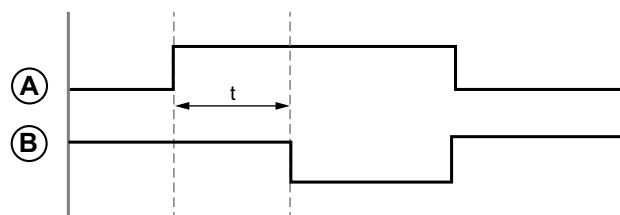

NOTE: The DI reset time is 30 ms.

Input Assignment

Input source	Description
Other	Do not use, reserved for future programmable feature.
Trip Reset DI	Used to configure the digital input for trip reset.
Breaker Close DI	Used in custom logic to customize the application. This input is not directly used by the motor starter logic.
Breaker Open DI	Used in custom logic to customize the application. This input is not directly used by the motor starter logic.
Local-START> DI	Local Forward Start command. Used by the motor starter logic as per the selected starter type.
Local-START>> DI	Local Fast Forward (Forward High speed) Start command. Used by the motor starter logic as per the selected starter type.
Local-STOP DI	Local Stop command. Used by the motor starter logic as per the selected starter type.
Local-START< DI	Local Reverse Start command. Used by the motor starter logic as per the selected starter type.
Local-START<< DI	Local Fast Reverse (Reverse High speed) Start command. Used by starter module as per the selected starter type.
Remote-START> DI	Remote Forward Start command. Used by the motor starter logic as per the selected starter type.
Remote-START>> DI	Remote Fast Forward (Forward High speed) Start command. Used by the motor starter logic as per the selected starter type.
Remote-STOP DI	Remote Stop command. Used by the motor starter logic as per the selected starter type.
Remote-START< DI	Remote Reverse Start command. Used by the motor starter logic as per the selected starter type.
Remote-START<< DI	Remote Fast Reverse (Reverse High speed) Start command. Used by the motor starter logic as per the selected starter type.
Interlock 1	Up to 12 digital inputs can be configured as interlocks. These interlock inputs are used by: <ul style="list-style-type: none"> • Motor starter logic to inhibit motor start, page 84. • Digital input interlock protection function, page 133.
Interlock 2	
Interlock 3	
Interlock 4	
Interlock 5	
Interlock 6	
Interlock 7	
Interlock 8	

Input source	Description
Interlock 9	
Interlock 10	
Interlock 11	
Interlock 12	
Contacteur open DI	Used in custom logic to customize the application. This input is not directly used by the motor starter logic.
Run DI	Used by the motor starter logic to check the contactor/RUN feedback.
Block Input	Used for co-ordination purpose. If the block input is present, the TeSys Tera system will block the trip output.
Logic test DI	Used to perform logic tests, page 89.
Mode selection 1	Used to select the operating mode: Local 1, Local 2, Local 3 or Remote, page 146.
Mode selection 2	
Forced start	Used by forced start function, page 165.
Forced stop	Used by the motor starter logic as forced stop.
Self test without trip	Used by test function.
Self test with trip	Used by test function.
None	–

Digital Outputs

▲ WARNING
<p>UNINTENDED MACHINE OPERATION</p> <ul style="list-style-type: none"> • Change in DO settings can cause short circuit or turn on power supply to the load. • Check if appropriate wiring is done according to the DO settings. • Ensure that the three-phase power supply is cut off while changing the DO settings. <p>Failure to follow these instructions can result in death, serious injury, or equipment damage.</p>

The TeSys Tera system supports maximum of 13 digital outputs:

- Three digital outputs on LTMT main units.
- Up to 10 digital outputs with LTMT expansion modules.

Output Configuration

The configuration of the digital outputs can be made through one of the following interfaces:

- A PC running the TeSys Tera DTM embedded in a FDT container such as SoMove software.
- The LTMTCUF control operator unit.
- A PLC or DCS through the communication network.

Each digital output has the following parameters:

Parameter	Setting range
Active type	<ul style="list-style-type: none"> • Active high • Active low
Output type	<ul style="list-style-type: none"> • Level • Pulse
Pulse time	0 to 60000 ms in step of 10 ms
Input source	See list in input source

The digital outputs are set by default depending on the motor starter type selected.

Output Type

The Active type, Output type, and Pulse time (t) parameters defines how the output information (A) is processed by the LTMT main unit and is converted in the physical information transmitted by the relay output (B).

Active High Level Outputs

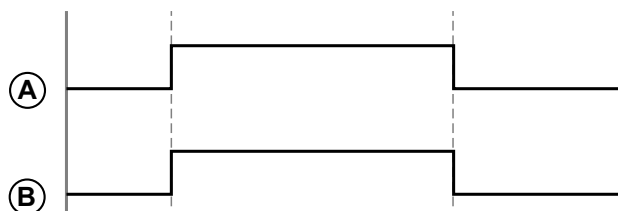

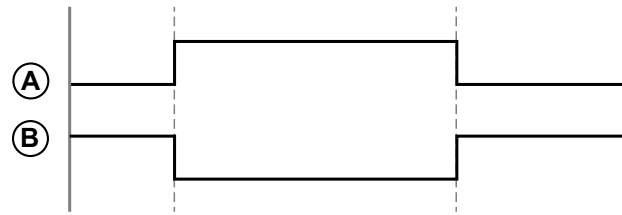
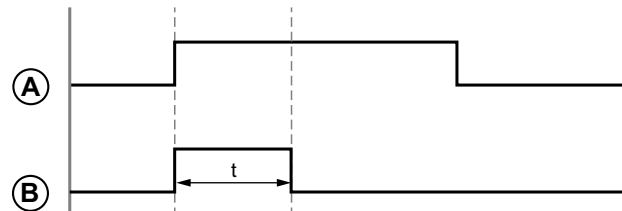
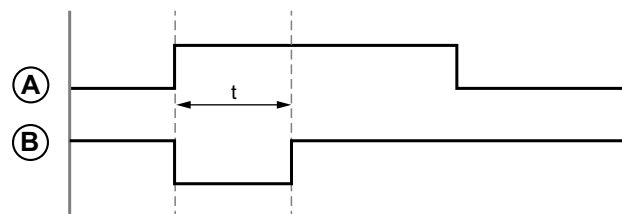
Active Low Level Outputs**Active High Pulse Outputs****Active Low Pulse Outputs**

DO Input Source

The most used input sources are indicated in the following table:

Index	Input source
232	Pickup status
233	Alarm status
234	Trip status
235	Motor stop error detection
504	CONTACTOR OUTPUT 1
505	CONTACTOR OUTPUT 2
506	CONTACTOR OUTPUT 3
507	CONTACTOR OUTPUT 4
508	CONTACTOR OUTPUT 5

Refer to in Appendices for the complete list of input source.

Motor Starter Functions

What's in This Chapter

Overload 154
 Direct Online..... 155
 Reverse Direct Online..... 159
 Star Delta 162
 Forced Start Function 165
 Single Phase Motor Application 166

▲ WARNING

UNINTENDED EQUIPMENT OPERATION

The application of this product requires expertise in the design and programming of control systems. Only personnel with such expertise should be allowed to program, install, configure, alter and apply this product. Follow all local and national safety codes and standards.

Failure to follow these instructions can result in death, serious injury, or equipment damage.

Overload

Description

In Overload starter, only two digital output is required for motor RUN command (CONTACTOR OUTPUT 1 (DO1) and Trip status (DO3)).

Wiring Diagram

Example of wiring diagram of the TeSys Tera system in Overload starter:

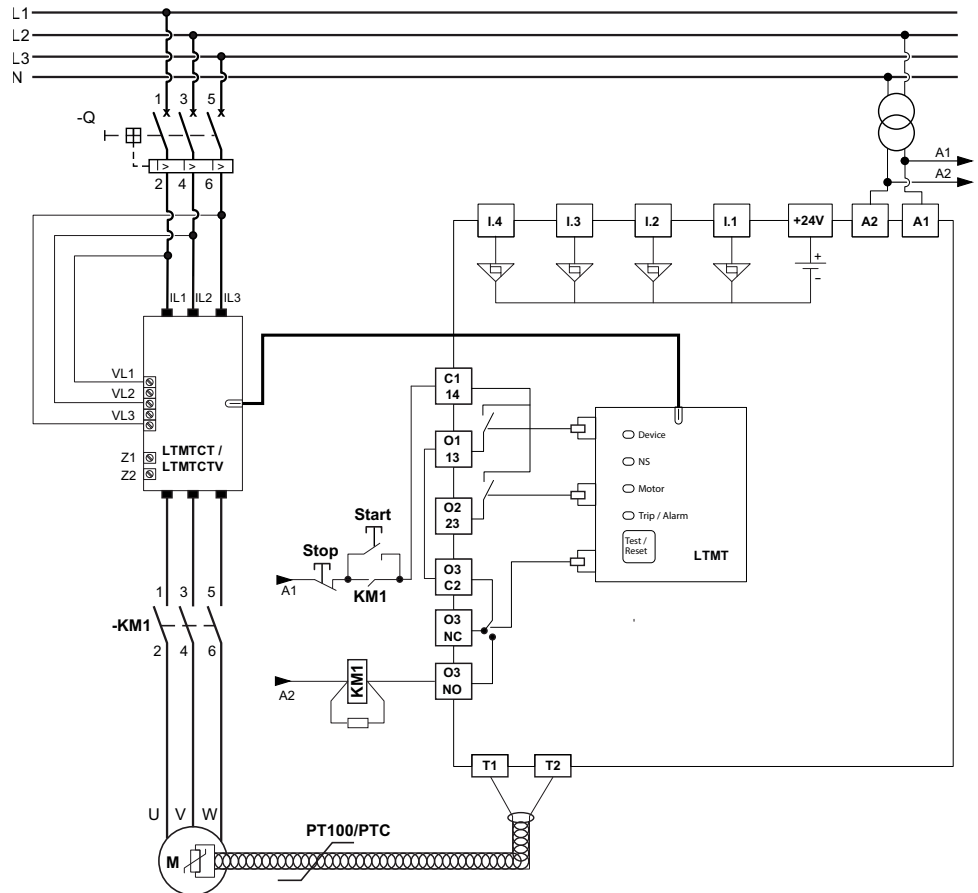

NOTE: Terminal O1 and O3 are connected in series.

Operating Principle

When Overload starter is selected, TeSys Tera system do not accept any start or stop command to control the motor. Start and stop has to be connected externally as shown in wiring diagram. In Overload mode, TeSys Tera system trips the motor on the occurrence of trip condition.

CONTACTOR OUTPUT 1 can be configured to any of the DO of TeSys Tera system. This enables the **Maximum start per hour** and the **Anti-backspin timer** functions in overload mode.

TeSys Tera system activates the CONTACTOR OUTPUT 1, if the motor is ready to start (that is no inhibit cause detected, page 84).

TeSys Tera system deactivates CONTACTOR OUTPUT 1, if any of the following motor stop cause is detected:

- Inhibit cause detected, page 84
- Trip detected

Combination of DO1 and DO3 will drive the motor.

DI/DO Default Assignment

When Overload starter type is selected, the default assignment and settings of digital inputs and digital outputs are as follows.

DI parameters	DI1 settings	DI2 settings	DI3 settings	DI4 settings
Trigger type	Active high	Active high	Active high	Active high
Input source	None	None	None	None
Validation time	10 ms	10 ms	10 ms	10 ms

DO parameters	DO1 settings	DO2 settings	DO3 settings
Active type	Active high	Active high	Active low
Input source	CONTACTOR OUTPUT 1	None	Trip status
Tag	Other	Other	Trip DO
Output type	Level	Level	Level
Pulse time	0 ms	0 ms	0 ms

Direct Online

Description

The Direct Online starter requires the following digital inputs and outputs:

- Two digital inputs for motor local start and local stop.
- One digital output for motor RUN command CONTACTOR OUTPUT 1.

Wiring Diagram

Example of wiring diagram of the TeSys Tera system in Direct Online mode:

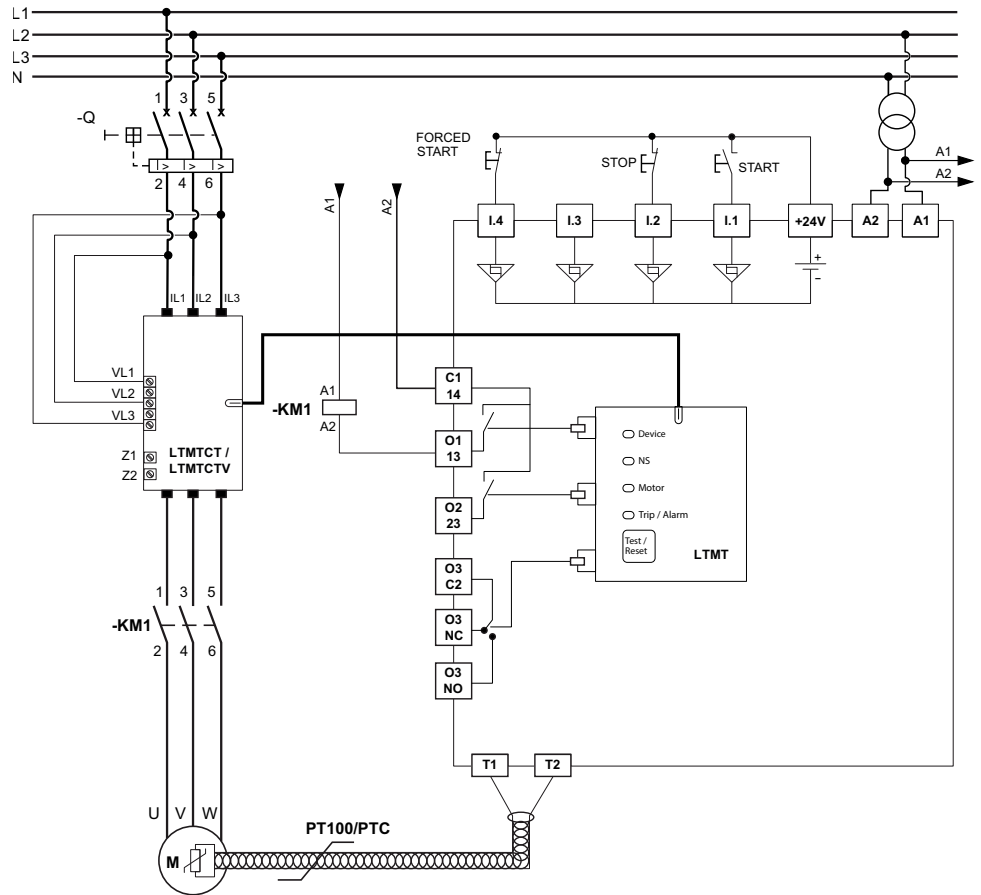

KM1: CONTACTOR OUTPUT 1

Logical Diagram

The following diagram shows the logical diagram of Direct Online starter.

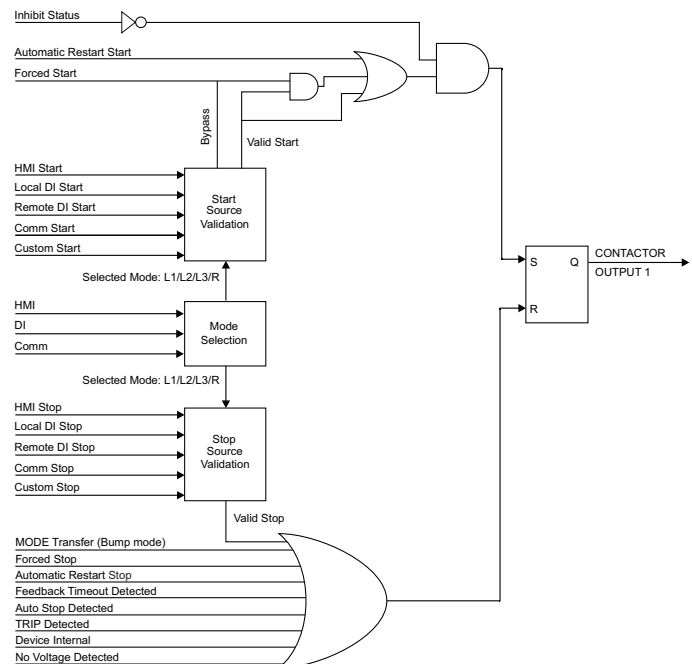

Operating Principle

When Direct Online mode is selected, motor start is possible from one of the following sources:

- Start command from valid source as per the selected operating mode, page 146.
- Start command from Forced start function, page 165.
- Start command from automatic restart function, page 174.

If a start command is received from either of the above source and if the motor is **Ready to Start** (that is no inhibit cause detected, page 84), then TeSys Tera system activates the CONTACTOR OUTPUT 1.

TeSys Tera system deactivates CONTACTOR OUTPUT 1, if any of the following motor stop cause is detected:

- Stop command from valid source as per the selected operating mode, page 146.
- Stop command from a digital input assigned to Forced stop (optional), refer to Input Assignment , page 149.
- Stop command from automatic restart function, page 174.
- Feedback timeout detected, page 143.
- Auto stop detected, page 143.
- Trip detected.
- Device Internal Error Detected, page 86.

DI/DO Default Assignment

When Direct Online starter type is selected, the default assignment and settings of digital inputs and digital outputs are as follows:

DI parameters	DI01 settings	DI02 settings	DI03 settings	DI04 settings
Trigger type	Active high	Active low	Active high	Active high
Input source	Local-START> DI	Local-STOP DI	Other	Mode Selection 1
Validation time	10 ms	10 ms	10 ms	10 ms

DO parameters	DO01 settings	DO02 settings	DO03 settings
Active type	Active high	Active high	Active high
Input source	CONTACTOR OUTPUT 1	Alarm Status	Trip Status
Tag	CNTR OP 1	Alarm DO	Trip DO
Output type	Level	Level	Level

Reverse Direct Online

Description

The Reverse Direct Online starter requires the following digital inputs and outputs:

- Three digital inputs for motor local start forward, local start reverse and local stop.
- Two digital outputs for motor RUN forward command (CONTACTOR OUTPUT 1) and RUN reverse command (CONTACTOR OUTPUT 2).

Wiring Diagram

Example of wiring diagram of the TeSys Tera system in Reverse Direct Online mode:

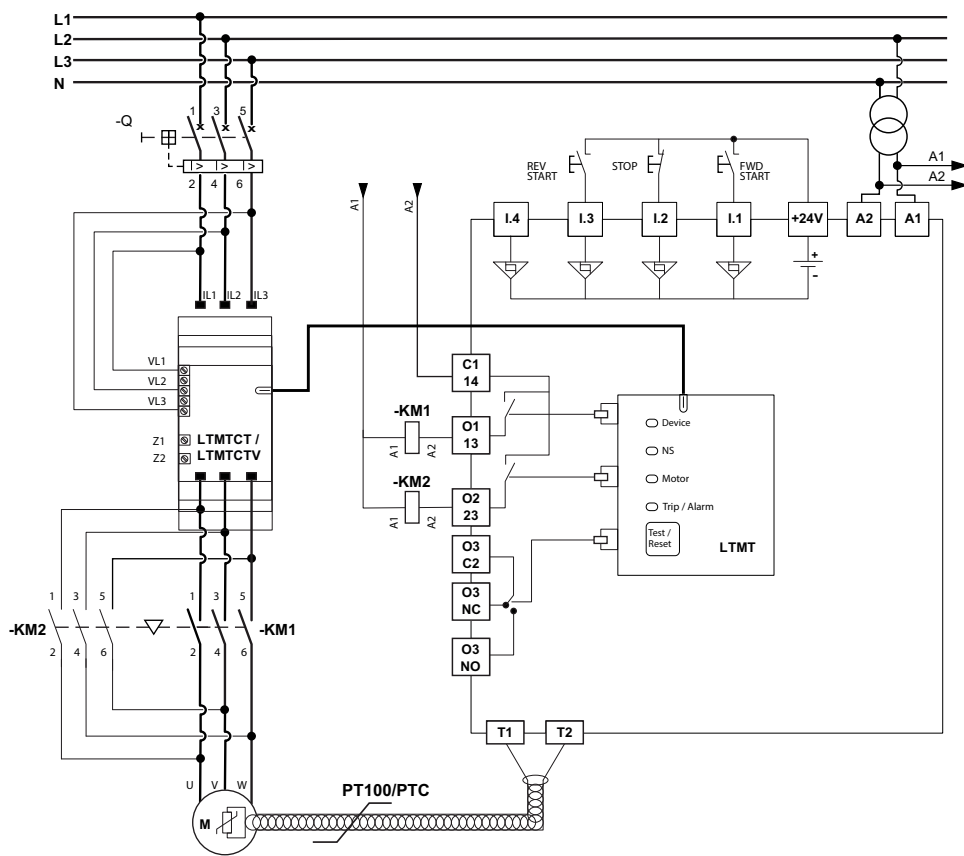

KM1: CONTACTOR OUTPUT 1 (Forward)

KM2: CONTACTOR OUTPUT 2 (Reverse)

NOTE: Mechanical interlock is connected to KM1 and KM2.

Logical Diagram

The following diagram shows the logical diagram of Reverse Direct Online starter.

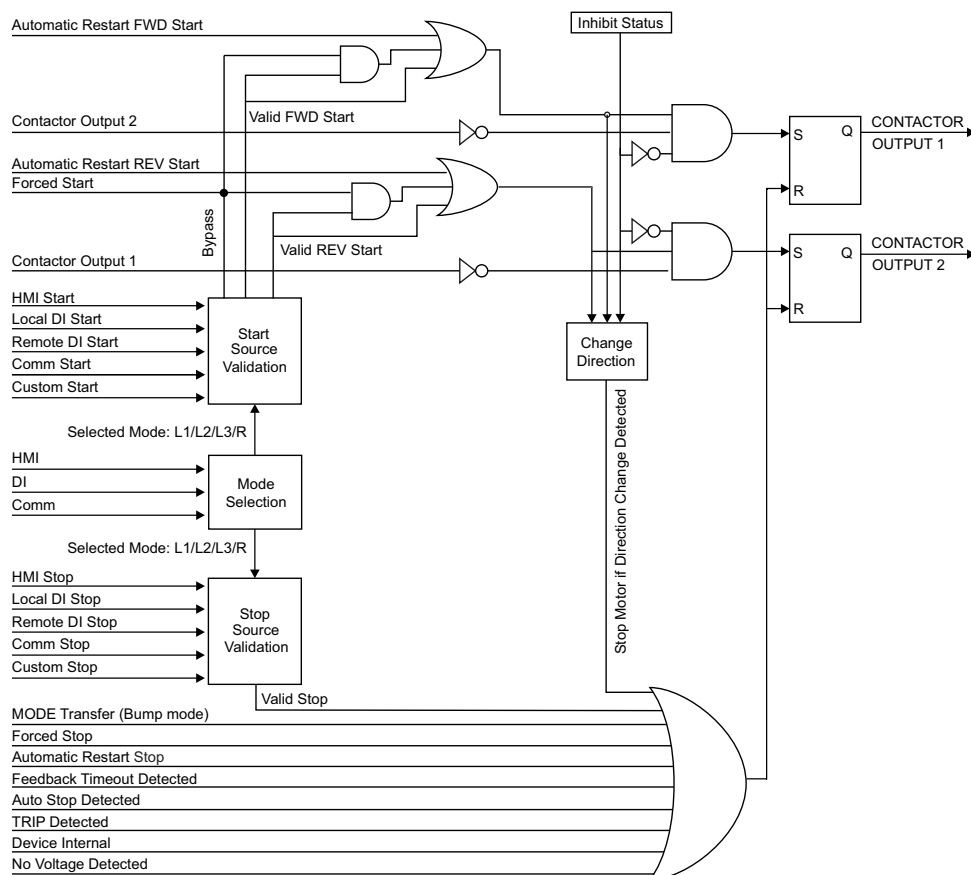

Operating Principle

When Reverse Direct Online mode is selected, motor start is possible from one of the following sources:

- Start command from valid source as per the selected operating mode, page 146.
- Start command from Forced start function, page 165.
- Start command from automatic restart function, page 174.

If a Forward Start command is received from either of the above source and if the motor is **Ready to Start** (that is no inhibit cause detected, page 84), then TeSys Tera system activates the forward main CONTACTOR OUTPUT 1.

Similarly, if a reverse start command is received from either of the above source and if the motor is ready to start (that is no inhibit cause detected, page 84), then TeSys Tera system activates the reverse main CONTACTOR OUTPUT 2.

The direction change logic depends on the Change Direction , page 144.

TeSys Tera system deactivates CONTACTOR OUTPUT 1, and CONTACTOR OUTPUT 2 if any of the following motor stop cause is detected:

- Stop command from valid source as per the selected operating mode, page 146.
- Stop command from a digital input assigned to Forced stop (optional), refer to Input Assignment , page 149.
- Stop command from automatic restart function, page 174.
- Feedback timeout detected, page 143.
- Auto stop detected, page 143.

- Trip detected.
- Device Internal Error Detected, page 86.

DI/DO Default Assignment

When Reverse Direct Online starter type is selected, the default assignment and settings of digital inputs and digital outputs are as follows:

DI parameters	DI01 settings	DI02 settings	DI03 settings	DI04 settings
Trigger type	Active high	Active low	Active high	Active high
Input source	Local-START> DI	Local-STOP DI	Local-START< DI	Mode Selection 1
Validation time	10 ms	10 ms	10 ms	10 ms

DO parameters	DO01 settings	DO02 settings	DO03 settings
Active type	Active high	Active high	Active high
Input source	CONTACTOR OUTPUT 1	CONTACTOR OUTPUT 2	Trip
Tag	CNTR OP 1	CNTR OP 2	Trip DO
Output type	Level	Level	Level

Star Delta

Description

The Star Delta starter requires the following digital inputs and outputs:

- Two inputs for motor local start and local stop.
- Three outputs for motor RUN command, star connection (CONTACTOR OUTPUT 1), main connection (CONTACTOR OUTPUT 2), and delta connection (CONTACTOR OUTPUT 3).

Wiring Diagram

Example of wiring diagram of the TeSys Tera system in Star Delta mode:

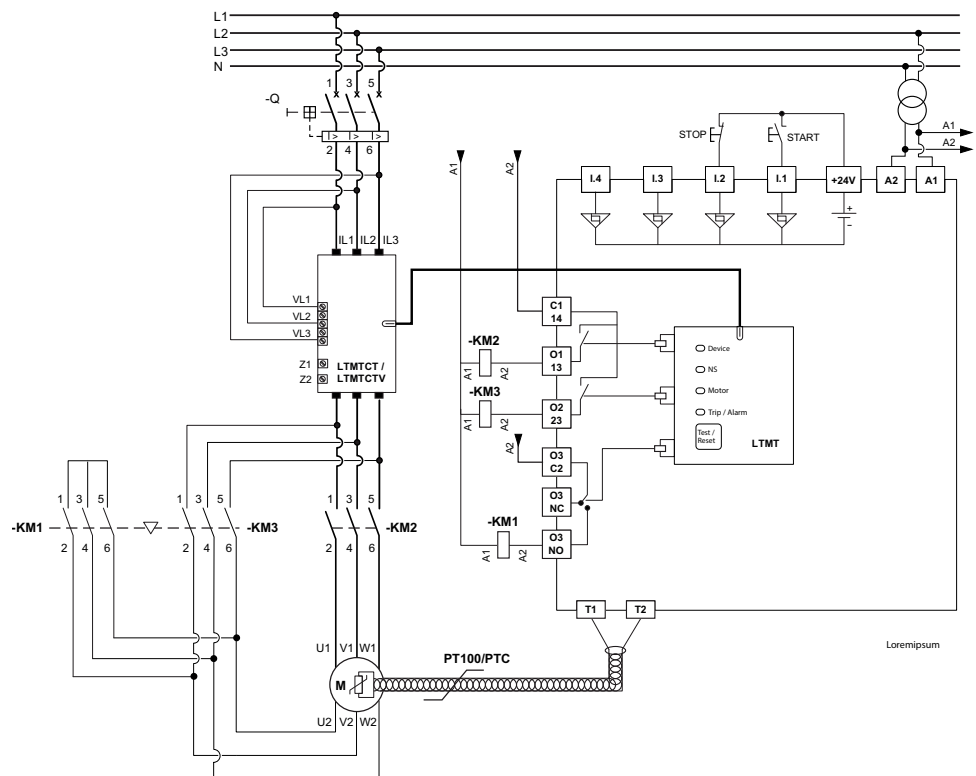

KM1: CONTACTOR OUTPUT 1 (Star)

KM2: CONTACTOR OUTPUT 2 (Main or Line)

KM3: CONTACTOR OUTPUT 3 (Delta)

NOTE: Mechanical interlock is connected to KM1 and KM3.

Logical Diagram

The following diagram shows the logical diagram of the Star Delta starter:

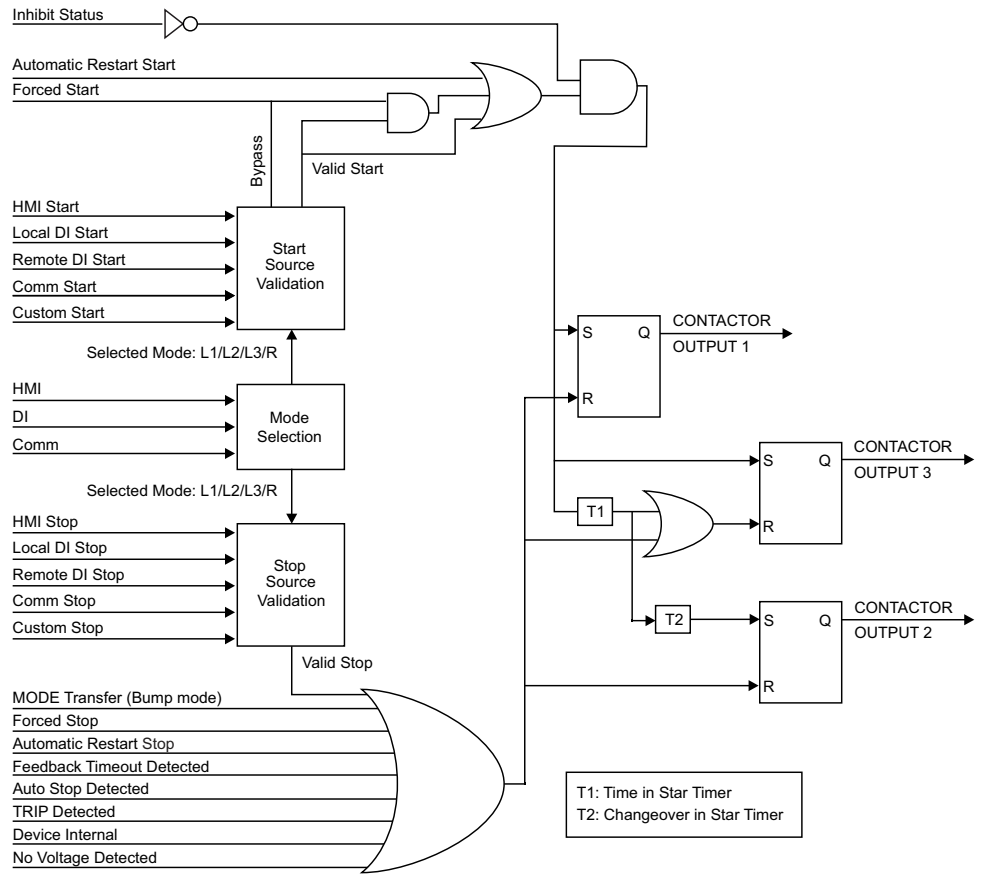

Operating Principle

When Star Delta mode is selected, motor start is possible from one of the following sources:

- Start command from valid source as per the selected operating mode, page 146.
- Start command from Forced start function, page 165.
- Start command from automatic restart function, page 174.

If a start command is received from either of the above source and if the motor is ready to start (that is no inhibit cause detected, page 84), then TeSys Tera system activates the star CONTACTOR OUTPUT 1 and main CONTACTOR OUTPUT 2 and starts the time in Star timer (T1 or delay 1).

Once the time in Star timer has elapsed, TeSys Tera system deactivates Star CONTACTOR OUTPUT 1 and starts the changeover timer (T2 or delay 2).

Once the changeover timer has elapsed, TeSys Tera system activates Delta CONTACTOR OUTPUT 3.

TeSys Tera system deactivates CONTACTOR OUTPUT 1, CONTACTOR OUTPUT 2, and CONTACTOR OUTPUT 3 if any of the following motor stop cause is detected:

- Stop command from valid source as per the selected operating mode, page 146.
- Stop command from a digital input assigned to Forced stop (optional), refer to Input Assignment, page 149.
- Stop command from automatic restart function, page 174.
- Feedback timeout detected, page 143.

- Auto stop detected, page 143.
- Trip detected.
- Device Internal Error Detected, page 86.

DI/DO Default Assignment

When Star Delta starter type is selected, the default assignment and settings of digital inputs and digital outputs are as follows:

DI parameters	DI01 settings	DI02 settings	DI03 settings	DI04 settings
Trigger type	Active high	Active low	Active high	Active high
Input source	Local-START> DI	Local-STOP DI	Other	Mode Selection 1
Validation time	10 ms	10 ms	10 ms	10 ms

DO parameters	DO01 settings	DO02 settings	DO03 settings
Active type	Active high	Active high	Active high
Input source	CONTACTOR OUTPUT 1	CONTACTOR OUTPUT 2	CONTACTOR OUTPUT 3
Tag	CNTR OP 1	CNTR OP 2	CNTR OP 3
Output type	Level	Level	Level

Delay Settings

Parameter	Description	Setting range	Default value
Delay 1	Start timer	0.01 to 600.00 s in step of 0.01 s	10.00 s
Delay 2	Changeover timer	0.01 to 600.00 s in step of 0.01 s	0.30 s

Forced Start Function

Description

Forced start function allows you to force the motor to start when the motor is in inhibit status due to thermal inhibit, thermal trip or maximum number of starts inhibit.

▲ WARNING

LOSS OF MOTOR PROTECTION

- Clearing the thermal inhibit or protection, and maximum number of starts inhibit can cause motor overheating or/and fire.
- Continued operation with inhibited thermal protection should be limited to applications where immediate restart is vital.

Failure to follow these instructions can result in death, serious injury, or equipment damage.

To configure forced start function:

- Enable forced start function, refer to *Motor Starter Settings*, page 140.
- Configure one digital input for forced start, refer to *Input Assignment*, page 149.
- Configure thermal overload protection with reset mode as Auto, refer to *Thermal Overload*, page 101.

Operating Principle

If the motor is stopped due to thermal trip or maximum number of starts reached, it is possible to force the motor to start by using the forced start digital input and one Start command from any source.

On detection of forced start digital input, TeSys Tera system waits for the start command from any source for 5 s.

On detection of forced start with start command from any of the source, TeSys Tera system bypasses the thermal inhibit, the thermal trip inhibit, Direction inhibit and maximum starts inhibit and activates the contactor output. During motor starting, TeSys Tera system forces or blocks the thermal memory to 90% or the block level if block function is enabled in thermal overload protection function till a time corresponding to the trip class setting is elapsed (time is 5 s for class 5 setting, 40 s for class 40 setting).

TeSys Tera system will stop the motor if any of the following motor stop cause is detected:

- Stop command from valid source as per the selected *Operating Mode*, page 146.
- Stop command from a digital input assigned to Forced stop (optional), refer to *Input Assignment*, page 149.
- Stop command from Auto restart function, page 174.
- Feedback timeout detected, page 143.
- Auto stop detected, page 143.
- Trip detected.
- Device internal error detected, page 86.

- Protection functions:
 - Motor Protection function:
 - **Thermal Overload**
 - **Stall Rotor**
 - **Locked Rotor**
 - Temperature protection
 - Current based protection:
 - **Definite Time Overcurrent**
 - **Normal Inverse Overcurrent**
 - **Short Time Overcurrent**
 - **Measured Ground Trip**
 - **Phase Under Current**
 - Voltage based protection:
 - **Phase Under voltage**
 - **Phase Over voltage**
 - Power protection function:
 - **Under Frequency**
 - **Over Frequency**
 - **Under Power**
 - **Over Power**
 - **Under Power Factor**
 - Digital Input interlock
 - **AI protection**
 - Motor Starter Functions:
 - DOL
 - Motor control function:
 - **Voltage Dip**
 - **Maximum Number of Starts**

Disabled Functions

In single-phase mode, following functions are disabled:

- Metering functions:
 - Current measurement : L2 and L3 RMS currents, current phase sequence, average current and current imbalance.
 - Voltage measurement : VL2-L3 and VL3-L1 RMS voltages, voltage phase sequence, average voltage and voltage Imbalance.
 - Calculated ground current.
 - THD measurement of L2 and L3 current and voltage.

- Protection functions:
 - Current based protection:
 - **Current Imbalance**
 - **Current Phase Loss**
 - **Current Phase Reversal**
 - Voltage based protection:
 - **Voltage Imbalance**
 - **Voltage Phase Loss**
 - **Voltage Phase Reversal**
 - Calculated ground trip protections.

Motor Control Function

What's in This Chapter

Maximum Number of Starts	170
Voltage Dip Management	171
Load Shedding	172
Auto Restart	174
Anti-Backspin Timer	180
Stop Error Detection	181
Block Output	183
Device internal protection	184

Maximum Number of Starts

Description

The maximum number of starts function helps to prevent the damage to the motor from frequent starts. This function allows the motor to start only for a pre-specified number within a given period of time. If the number of starts exceeds the set value, then this function keeps the LTMT main unit in inhibit mode, which helps to prevent any further motor start.

Parameter Setting

The maximum number of starts function has the following configurable settings:

Parameter	Setting range	Default value
Function	<ul style="list-style-type: none"> • Disable • Enable 	Enable
Permissive Starts	1–30 in step of 1	6 starts
Reference Time	15–60 m in step of 1	30 m
Inhibit Period	1–120 m in step of 1	5 m
Time between Starts	0–120 m in step of 1	0 m

The parameter of maximum number of starts function has the following features:

- Permissive starts: Motor starts are allowed within the defined reference time.
- Reference Time: The motor start time must be limited in accordance with the configured permissive starts.
- Inhibit period: The period to inhibit the motor, after the last permissible start.
- Time between starts: Maintained the time gap between the two permissive starts.

Voltage Dip Management

Overview

When a voltage dip is detected, the LTMT main unit can perform two different functions to shed and reconnect the load automatically.

Selection is done through the voltage dip mode parameter:

If Voltage Dip Mode is	Then
None	Voltage dip functions are disabled
Load Shedding	Load shedding function is enabled, page 172
Auto Restart	Auto Restart function is enabled , page 174

Load Shedding and Auto Restart functions exclude each other.

Load Shedding

Description

The LTMT main unit provides load shedding, which you can use to deactivate non-critical loads if voltage level is substantially reduced. For example, use load shedding when power is transferred from a main utility supply to a backup generator system, where the backup generator system can supply power only to a limited number of critical loads.

The LTMT main unit only monitors load shedding when Load Shedding is selected.

With the load shedding function enabled, the LTMT main unit monitors the average phase voltage and:

- Reports a load shedding condition and stops the motor when voltage falls below a configurable voltage dip threshold and stays below the threshold for the duration of a configurable load shedding timer.
- Clears the load shedding condition when voltage rises above a configurable Voltage dip restart threshold and remains above the threshold for the duration of a configurable load shedding restart timer.

When the LTMT main unit clears the load shedding condition:

- In Maintained start configuration, it issues a Run command to restart the motor.
- In Momentary start configuration, it does not automatically restart the motor.

If your application includes another device that externally provides load shedding, the LTMT main unit load shedding function should not be enabled.

All voltage dip thresholds and timers can be adjusted when the LTMT main unit is in its normal operating state. When a load shedding timer is counting at the time it is adjusted, the new duration time does not become effective until the timer expires.

Functional Characteristics

The load shedding function includes the following features:

- Two thresholds
 - Voltage Dip Threshold
 - Voltage Dip Restart Threshold
- Two time delays
 - Load Shedding Timeout
 - Voltage Dip Restart Timeout
- One status flag
 - Load Shedding
- One counting statistic
 - Load Sheddings Count

Parameter Settings

The load shedding function has the following parameters:

Parameter	Setting range	Default value
Function	<ul style="list-style-type: none"> • Disable • Load shedding • Auto restart 	Disable
Load Shedding Timeout	1–9999 s in step of 1 s	10 s
Voltage dip threshold	20–90% of nominal voltage in step of 5%	90% of nominal voltage
Voltage Dip Restart Timeout	0–9999 s in step of 1 s	2 s
Voltage dip restart threshold	20 -95% of nominal voltage in step of 5%	95% of nominal voltage

Technical Characteristics

The load shedding function has the following characteristics:

Characteristics	Value
Trip time accuracy	+/- 0.1 s or +/- 5%

Timing Sequence

The following diagram is an example of the timing sequence for the load shedding function, for a maintained start configuration with automatic restart:

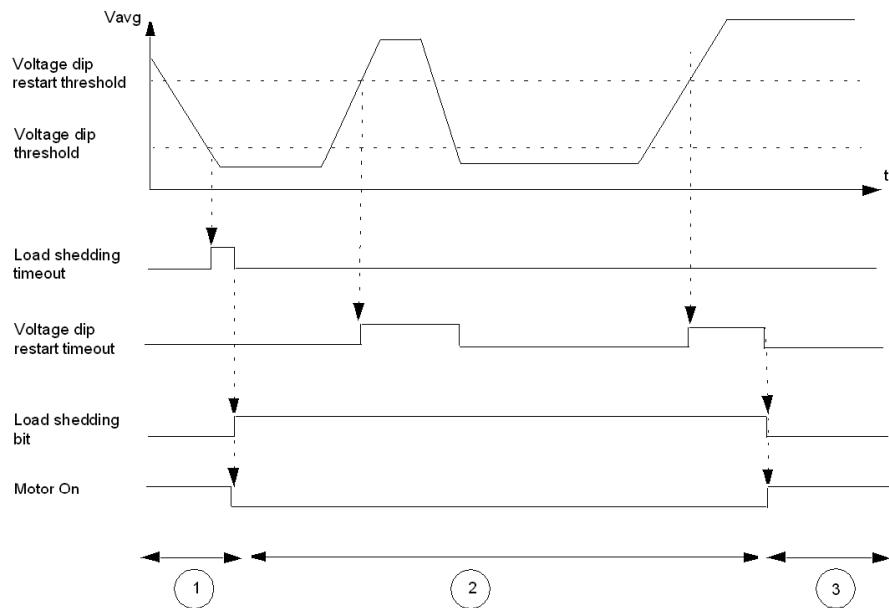

1 Motor running

2 Load shed; motor stopped

3 Load shed cleared; motor auto-restart (maintained operation)

Auto Restart

Description

The LTMT main unit provides auto restart.

With the auto restart function enabled, the LTMT main unit monitors the instantaneous phase voltage and detects voltage dip conditions. The voltage dip detection shares some parameters with the load shedding function.

Three restart sequences are managed by the function according to the duration of the voltage dip:

- Immediate restart: The motor restarts automatically.
- Delayed restart: The motor restarts automatically after a timeout.
- Manual restart: The motor restarts manually. A Run command is necessary.

All auto restart timers can be adjusted when the LTMT main unit is in its normal operating state. When an auto restart timer is counting at the time it is adjusted, the new duration time does not become effective until the timer expires.

Functional Characteristics

The auto restart function includes the following features:

- Three time delays:
 - Auto Restart Immediate Timeout
 - Auto Restart Delayed Timeout
 - Voltage Dip Restart Timeout
- Five status flags:
 - Voltage Dip Detection: the LTMT main unit is in a dip condition
 - Voltage Dip Occurred: a dip has been detected in the last 4.5 s
 - Auto Restart Immediate Condition
 - Auto Restart Delayed Condition
 - Auto Restart Manual Condition
- Three counting statistics:
 - Auto Restart Immediate Count
 - Auto Restart Delayed Count
 - Auto Restart Manual Count

Parameter Settings

The auto restart function has the following parameters:

Parameter	Setting range	Default value
Voltage dip mode	<ul style="list-style-type: none"> • Disable • Load shedding • Auto restart 	Disable
Voltage dip threshold	20–90% of nominal voltage	90% of nominal voltage
Voltage dip restart threshold	20–95% of nominal voltage	95% of nominal voltage
Auto restart immediate timeout	0–0.4 s in increments of 0.1 s	0.2 s

Parameter	Setting range	Default value
Auto restart delayed timeout	<ul style="list-style-type: none"> 0–300 s: timeout setting in increments of 1 s 301 s: timeout infinite 	4 s
Voltage dip restart timeout	0–9999 s in increments of 1 s	2 s
Bypass Stop DI	<ul style="list-style-type: none"> Disable Enable 	Disable

Technical Characteristics

The auto restart function has the following characteristics:

Characteristics	Value
Timing accuracy	+/- 0.1 s or +/- 5%

Auto Restart Behavior

The auto restart behavior is characterized by the voltage dip duration that is the amount of time passed from the voltage loss until the voltage restoration.

The two possible settings are:

- Immediate restart timeout.
- Delayed restart timeout (with delay defined by Restart Delay Time).

The following diagram shows the auto restart phases:

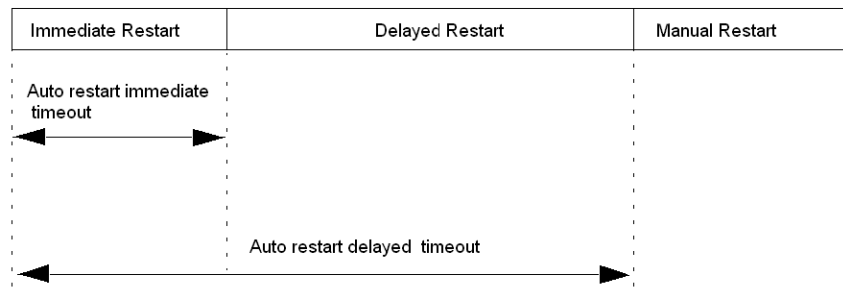

If the voltage dip duration is less than the immediate restart timeout and if the voltage dip is the second one occurring within 1 s, then the motor will require a delayed restart.

When a delayed restart is active (the delay timer is running):

- The timer is paused for the duration of the dip if a voltage dip occurs.
- The delayed restart is canceled if a start or stop command occurs.

Timing Sequence - Immediate Restart

The following diagram is an example of the timing sequence when an immediate restart occurs:

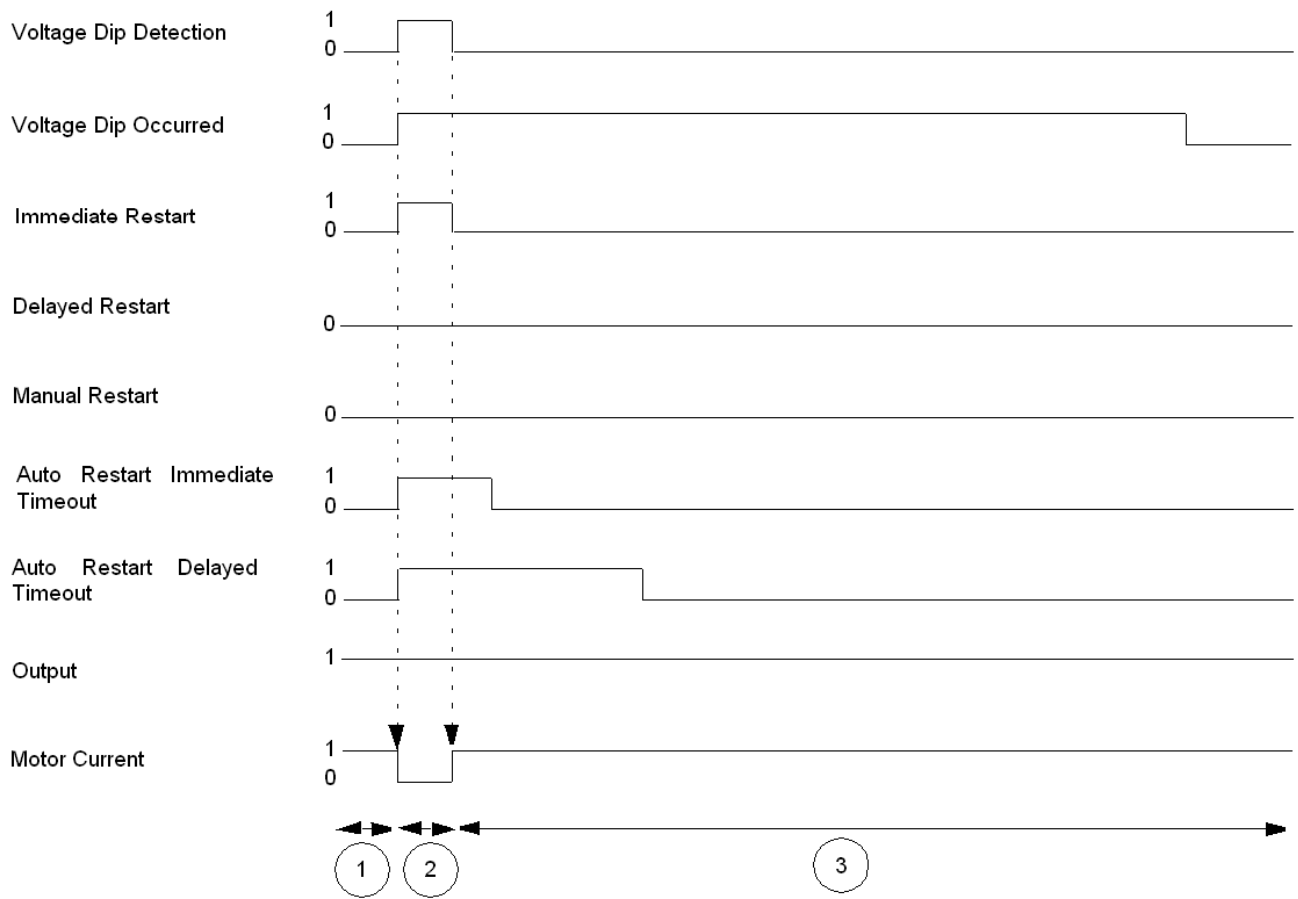

1 Motor running

2 Voltage dip detected, motor stopped

3 Voltage dip cleared, motor auto restart

Timing Sequence - Delayed Restart

The following diagram is an example of the timing sequence when a delayed restart occurs:

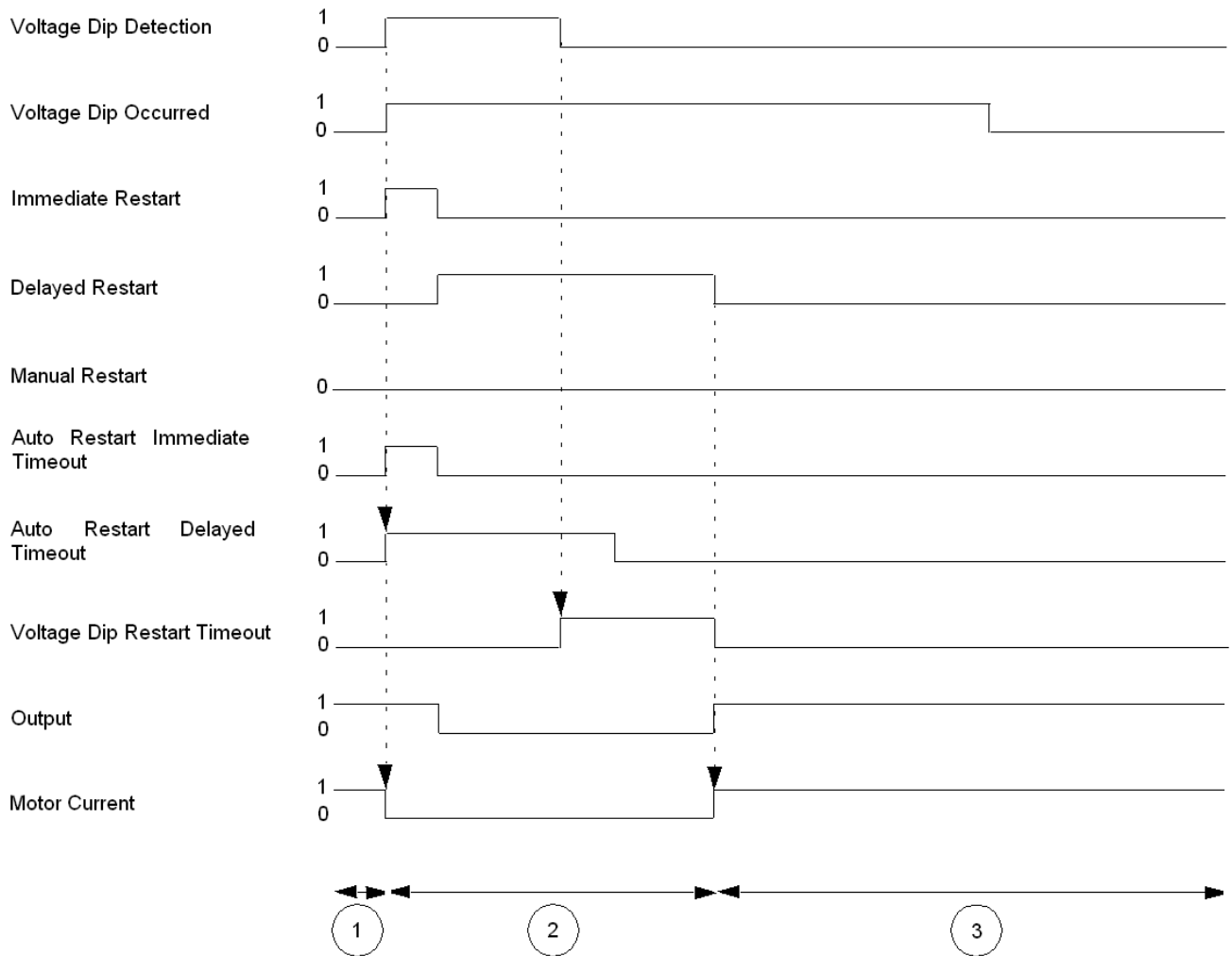

1 Motor running

2 Voltage dip detected, motor stopped

3 Voltage dip cleared, motor auto restart

Timing Sequence - Manual Restart

The following diagram is an example of the timing sequence when a manual restart occurs:

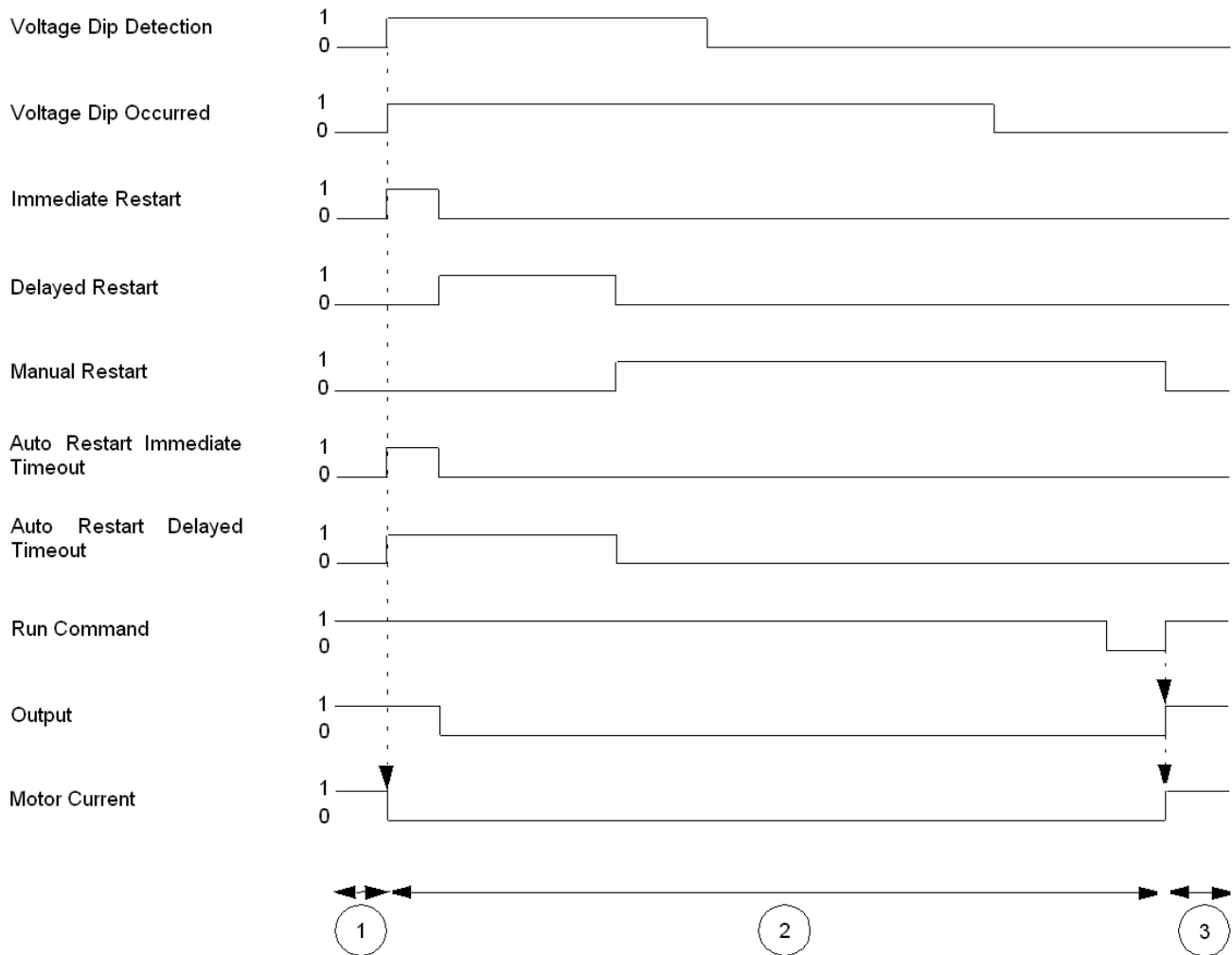

1 Motor running

2 Voltage dip detected, motor stopped

3 Voltage dip cleared, motor auto restart

Bypass Stop DI

If the bypass Stop DI function is enabled and a voltage dip occurs, TeSys Tera system bypasses the stop command received through DI (Local Stop DI and Remote Stop DI).

If there is no voltage dip, the TeSys Tera system will not bypass the stop command, even if the bypass Stop DI is enabled.

NOTE: This function is applicable only with auto restart function.

DANGER

HAZARD OF ELECTRIC SHOCK, EXPLOSION, OR ARC FLASH

- If Bypass Stop function is enabled, use appropriate external interlocks to stop the motor.
- Configure appropriate voltage dip, restore threshold and nominal voltage.
- Post installation and configuration, the motor control functionality should be checked before energizing the motor.

Failure to follow these instructions will result in death or serious injury.

Anti-Backspin Timer

Description

Anti-Backspin timer is used to wait until the motor is mechanically stopped.

Once the motor is stopped (electrically), this function keeps the LTMT main unit in inhibit mode until the predefined time delay has elapsed.

Parameter Setting

The anti-backspin timer function has the following configurable settings:

Parameter	Setting range	Default value
Function	<ul style="list-style-type: none">• Disable• Enable	Disable
Time Delay	0–60000 s in step of 1 s	0 s

Stop Error Detection

Description

If after giving the Stop command, due to welded contactor, if the motor does not stop, in such cases, motor stop error detection function gives the trip signal to stop the motor in alternate way.

This function monitors the current after the Stop signal is set. If any of the three phase currents is still present for the time specified in time delay setting, after the Stop signal is set, then the function triggers a trip signal.

NOTE: Make sure that the motor stop error detection trip signal is configured to any of the TeSys Tera digital output to control the alternate contactor or to inform upstream devices.

Parameter Setting

The Motor stop error detection function has the following configurable settings:

Parameter	Setting range	Default value
Function	<ul style="list-style-type: none">• Disable• Enable	Disable
Time Delay	0.1–6000.0 s in step of 0.1 s	1 s
Reset Mode	<ul style="list-style-type: none">• Reset key• DI• Communication	DI + Reset Key

Block Output

Description

The **Block Output** function gives indication to upstream relays to block the trip, if one of the following protection functions detects a trip:

- Short time over-current protection
- Calculated ground trip protection
- Measured ground trip protection

If TeSys Tera system detects pickup of any of the above mentioned protection, TeSys Tera system **Block Output** will be active which can be configured to digital output to inform upstream relays. Once TeSys Tera system issues trip for any of the above mentioned protection, the Block Output will be deactivated after the **Contactor/Breaker Open Time** set.

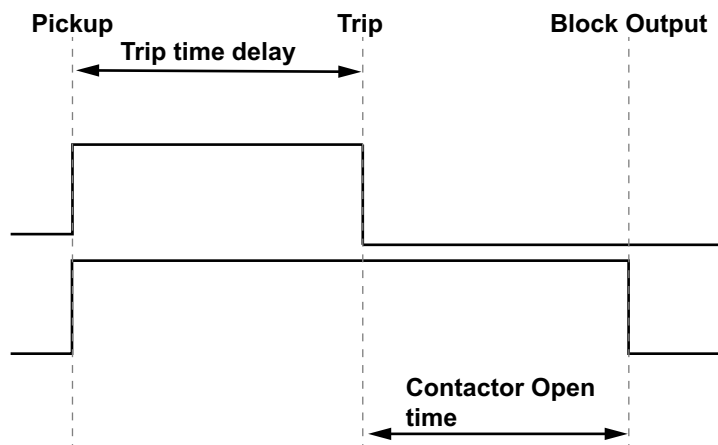

Parameters Settings

The **Block Output** function has the following configurable settings:

Parameter	Setting range	Default Value
Function	<ul style="list-style-type: none"> • Disable • Enable 	Disable
Contactor/Breaker Open Time	0.00–600.00 s in step of 0.01 s	0 s

Device internal protection

Parameters Settings

The **Device Internal** protection function has the following configurable settings:

Parameter	Setting range	Default Value
Time Delay	0.1–6000.00 s in step of 0.01 s	1 s
Reset Mode	<ul style="list-style-type: none">• Reset key• DI• Communication	DI + Reset Key

NOTE: The **Device Internal** trip occurs if any of these diagnostic detected after the time delay. For more information, refer *Device Internal Error Detected*, page 86.

Appendices

What's in This Part

Trip Code..... 186
Event Code..... 188
Device Internal Error Code..... 206
Input Source 208

Trip Code

Trip code	Trip description
1	Thermal overload trip
2	Locked rotor trip
3	Stalled rotor trip
4	Definite time overcurrent trip
5	Normal inverse overcurrent trip
6	Short time overcurrent trip
7	Calculated ground trip
8	Measured ground trip
9	Phase under current trip
10	Current imbalance trip
11	Current phase loss trip
12	Current phase reversal trip
13	Phase under voltage trip
14	Phase over voltage trip
15	Voltage phase loss trip
16	Voltage imbalance trip
17	Voltage phase reversal trip
18	Under frequency trip
19	Over frequency trip
20	Excessive start time trip
21	Communication loss trip
22	Over Temperature trip
23	Under power trip
24	Over power trip
25	Under power factor trip
26	Reserved
27	Device internal trip
28	HMI communication loss trip
29	Wiring error detection trip
30-32	Reserved
33	Interlock 1 trip
34	Interlock 2 trip
35	Interlock 3 trip
36	Interlock 4 trip
37	Interlock 5 trip
38	Interlock 6 trip
39	Interlock 7 trip
40	Interlock 8 trip
41	Interlock 9 trip
42	Interlock 10 trip

Trip code	Trip description
43	Interlock 11 trip
44	Interlock 12 trip
45-64	Reserved
65	Analog input 1 trip
66	Analog input 2 trip
67	Analog input 3 trip
68	Analog input 4 trip
69-94	Reserved
95	Stucked reset key
96	Logic test interrupted trip
97	Motor stop error detection trip
98	Reserved

Event Code

Alarm Events

Event code	Description
1	Thermal overload alarm
2	Thermal overload alarm reset
3	Locked rotor alarm
4	Locked rotor alarm reset
5	Stalled rotor alarm
6	Stalled rotor alarm reset
7	Definite time overcurrent alarm
8	Definite time overcurrent alarm reset
9	Normal inverse overcurrent alarm
10	Normal inverse overcurrent alarm reset
11	Short time overcurrent alarm
12	Short time overcurrent alarm reset
13	Calculated ground trip alarm
14	Calculated ground fault trip reset
15	Measured ground trip alarm
16	Measured ground fault trip reset
17	Phase under current alarm
18	Phase under current alarm reset
19	Current imbalance alarm
20	Current imbalance alarm reset
21	Current phase loss alarm
22	Current phase loss alarm reset
23	Current phase reversal alarm
24	Current phase reversal alarm reset
25	Phase under voltage alarm
26	Phase under voltage alarm reset
27	Phase over voltage alarm
28	Phase over voltage alarm reset
29	Voltage phase loss alarm
30	Voltage phase loss alarm reset
31	Voltage imbalance alarm
32	Voltage imbalance alarm reset
33	Voltage phase reversal alarm
34	Voltage phase reversal alarm reset
35	Under frequency alarm
36	Under frequency alarm reset
37	Over frequency alarm
38	Over frequency alarm reset
39-40	Reserved

Event code	Description
41	Communication loss alarm
42	Communication loss alarm reset
43	Over temperature alarm
44	Over temperature alarm reset
45	Under power alarm
46	Under power alarm reset
47	Over power alarm
48	Over power alarm reset
49	Under power factor alarm
50	Under power factor alarm reset
51-54	Reserved
55	HMI communication loss alarm
56	HMI communication loss alarm reset
57-64	Reserved
65	Interlock 1 alarm
66	Interlock 1 alarm reset
67	Interlock 2 alarm
68	Interlock 2 alarm reset
69	Interlock 3 alarm
70	Interlock 3 alarm reset
71	Interlock 4 alarm
72	Interlock 4 alarm reset
73	Interlock 5 alarm
74	Interlock 5 alarm reset
75	Interlock 6 alarm
76	Interlock 6 alarm reset
77	Interlock 7 alarm
78	Interlock 7 alarm reset
79	Interlock 8 alarm
80	Interlock 8 alarm reset
81	Interlock 9 alarm
82	Interlock 9 alarm reset
83	Interlock 10 alarm
84	Interlock 10 alarm reset
85	Interlock 11 alarm
86	Interlock 11 alarm reset
87	Interlock 12 alarm
88	Interlock 12 alarm reset
89–128	Reserved
129	A11 alarm
130	A11 alarm reset
131	A12 alarm
132	A12 alarm reset
133	A13 alarm
134	A13 alarm reset
135	A14 alarm

Event code	Description
136	AI4 alarm reset
137-192	Reserved

Pickup Events

Event code	Description
193	Thermal overload pickup
194	Thermal overload pickup reset
195	Locked rotor pickup
196	Locked rotor pickup reset
197	Stalled rotor pickup
198	Stalled rotor pickup reset
199	Definite time overcurrent pickup
200	Definite time overcurrent pickup reset
201	Normal inverse overcurrent pickup
202	Normal inverse overcurrent pickup reset
203	Short time overcurrent pickup
204	Short time overcurrent pickup reset
205	Calculated ground trip pickup
206	Calculated ground trip pickup reset
207	Measured ground trip pickup
208	Measured ground trip pickup reset
209	Phase under current pickup
210	Phase under current pickup reset
211	Current imbalance pickup
212	Current imbalance pickup reset
213	Current phase loss pickup
214	Current phase loss pickup reset
215	Current phase reversal pickup
216	Current phase reversal pickup reset
217	Phase under voltage pickup
218	Phase under voltage pickup reset
219	Phase over voltage pickup
220	Phase over voltage pickup reset
221	Voltage phase loss pickup
222	Voltage phase loss pickup reset
223	Voltage imbalance pickup
224	Voltage imbalance pickup reset
225	Voltage phase reversal pickup
226	Voltage phase reversal pickup reset
227	Under frequency pickup

Event code	Description
228	Under frequency pickup reset
229	Over frequency pickup
230	Over frequency pickup reset
231	Excessive start time pickup
232	Excessive start time pickup reset
233	Communication loss pickup
234	Communication loss pickup reset
235	Over temperature pickup
236	Over temperature pickup reset
237	Under power pickup
238	Under power pickup reset
239	Over power pickup
240	Over power pickup reset
241	Under power factor pickup
242	Under power factor pickup reset
243-244	Reserved
245	Device internal pickup
246	Device internal pickup reset
247	HMI communication loss pickup
248	HMI communication loss pickup reset
249-256	Reserved
257	Interlock 1 pickup
258	Interlock 1 pickup reset
259	Interlock 2 pickup
260	Interlock 2 pickup reset
261	Interlock 3 pickup
262	Interlock 3 pickup reset
263	Interlock 4 pickup
264	Interlock 4 pickup reset
265	Interlock 5 pickup
266	Interlock 5 pickup reset
267	Interlock 6 pickup
268	Interlock 6 pickup reset
269	Interlock 7 pickup
270	Interlock 7 pickup reset
271	Interlock 8 pickup
272	Interlock 8 pickup reset
273	Interlock 9 pickup
274	Interlock 9 pickup reset
275	Interlock 10 pickup
276	Interlock 10 pickup reset
277	Interlock 11 pickup

Event code	Description
278	Interlock 11 pickup reset
279	Interlock 12 pickup
280	Interlock 12 pickup reset
281-320	Reserved
321	AI1 pickup
322	AI1 pickup reset
323	AI2 pickup
324	AI2 pickup reset
325	AI3 pickup
326	AI3 pickup reset
327	AI4 pickup
328	AI4 pickup reset
329-384	Reserved

Digital Input Events

Event code	Description
385	DI 1 ON
386	DI 1 OFF
387	DI 2 ON
388	DI 2 OFF
389	DI 3 ON
390	DI 3 OFF
391	DI 4 ON
392	DI 4 OFF
393	DI 5 ON
394	DI 5 OFF
395	DI 6 ON
396	DI 6 OFF
397	DI 7 ON
398	DI 7 OFF
399	DI 8 ON
400	DI 8 OFF
401	DI 9 ON
402	DI 9 OFF
403	DI 10 ON
404	DI 10 OFF
405	DI 11 ON
406	DI 11 OFF
407	DI 12 ON
408	DI 12 OFF
409	DI 13 ON
410	DI 13 OFF
411	DI 14 ON

Event code	Description
412	DI 14 OFF
413	DI 15 ON
414	DI 15 OFF
415	DI 16 ON
416	DI 16 OFF
417	DI 17 ON
418	DI 17 OFF
419	DI 18 ON
420	DI 18 OFF
421	DI 19 ON
422	DI 19 OFF
423	DI 20 ON
424	DI 20 OFF
425	DI 21 ON
426	DI 21 OFF
427	DI 22 ON
428	DI 22 OFF
429	DI 23 ON
430	DI 23 OFF
431	DI 24 ON
432	DI 24 OFF
433–448	Reserved

Digital Output Events

Event code	Description
449	DO 1 ON
450	DO 1 OFF
451	DO 2 ON
452	DO 2 OFF
453	DO 3 ON
454	DO 3 OFF
455	DO 4 ON
456	DO 4 OFF
457	DO 5 ON
458	DO 5 OFF
459	DO 6 ON
460	DO 6 OFF
461	DO 7 ON
462	DO 7 OFF
463	DO 8 ON
464	DO 8 OFF
465	DO 9 ON
466	DO 9 OFF
467	DO 10 ON

Event code	Description
468	DO 10 OFF
469	DO 11 ON
470	DO 11 OFF
471	DO 12 ON
472	DO 12 OFF
473	DO 13 ON
474	DO 13 OFF
475-512	Reserved

Digital Input Events

Event code	Description
513	Trip reset DI ON
514	Trip reset DI OFF
515	Breaker close DI ON
516	Breaker close DI OFF
517	Breaker open DI ON
518	Breaker open DI OFF
519	Local-START> DI ON
520	Local-START> DI OFF
521	Local-START>> DI ON
522	Local-START>> DI OFF
523	Local-STOP DI ON
524	Local-STOP DI OFF
525	Local-START< DI ON
526	Local-START< DI OFF
527	Local-START<< DI ON
528	Local-START<< DI OFF
529	Remote-START> DI ON
530	Remote-START> DI OFF
531	Remote-START>> DI ON
532	Remote-START>> DI OFF
533	Remote-STOP DI ON
534	Remote-STOP DI OFF
535	Remote-START< DI ON
536	Remote-START< DI OFF
537	Remote-START<< DI ON
538	Remote-START<< DI OFF
539	Interlock 1 DI ON
540	Interlock 1 DI OFF
541	Interlock 2 DI ON
542	Interlock 2 DI OFF
543	Interlock 3 DI ON
544	Interlock 3 DI OFF

Event code	Description
545	Interlock 4 DI ON
546	Interlock 4 DI OFF
547	Interlock 5 DI ON
548	Interlock 5 DI OFF
549	Interlock 6 DI ON
550	Interlock 6 DI OFF
551	Interlock 7 DI ON
552	Interlock 7 DI OFF
553	Interlock 8 DI ON
554	Interlock 8 DI OFF
555	Interlock 9 DI ON
556	Interlock 9 DI OFF
557	Interlock 10 DI ON
558	Interlock 10 DI OFF
559	Interlock 11 DI ON
560	Interlock 11 DI OFF
561	Interlock 12 DI ON
562	Interlock 12 DI OFF
563	Contactator open DI ON
564	Contactator open DI OFF
565	RUN DI ON
566	RUN DI OFF
567	Block input DI ON
568	Block input DI OFF
569	Logic test DI ON
570	Logic test DI OFF
571	Mode selection 1 DI ON
572	Mode selection 1 DI OFF
573	Mode selection 2 DI ON
574	Mode selection 2 DI OFF
575	Speed change DI ON
576	Speed change DI OFF
577	Forced start DI ON
578	Forced start DI OFF
579	Forced stop DI ON
580	Forced stop DI OFF
581	Self test without trip DI ON
582	Self test without trip DI OFF
583	Self test with trip DI ON
584	Self test with trip DI OFF
585	Soft starter reset DI ON
586	Soft starter reset DI OFF
587-640	Reserved

Inhibit Events

Event code	Description
641	No voltage inhibit
642	No voltage inhibit reset
643	Under voltage inhibit
644	Under voltage inhibit reset
645	Trip inhibit
646	Trip inhibit reset
647	Thermal inhibit
648	Thermal inhibit reset
649	Max starts inhibit
650	Max starts inhibit reset
651	Interlock 1 inhibit
652	Interlock 1 inhibit reset
653	Interlock 2 inhibit
654	Interlock 2 inhibit reset
655	Interlock 3 inhibit
656	Interlock 3 inhibit reset
657	Interlock 4 inhibit
658	Interlock 4 inhibit reset
659	Interlock 5 inhibit
660	Interlock 5 inhibit reset
661	Interlock 6 inhibit
662	Interlock 6 inhibit reset
663	Interlock 7 inhibit
664	Interlock 7 inhibit reset
665	Interlock 8 inhibit
666	Interlock 8 inhibit reset
667	Interlock 9 inhibit
668	Interlock 9 inhibit reset
669	Interlock 10 inhibit
670	Interlock 10 inhibit reset
671	Interlock 11 inhibit
672	Interlock 11 inhibit reset
673	Interlock 12 inhibit
674	Interlock 12 inhibit reset
675	Local DI stop inhibit
676	Local DI stop inhibit reset
677	Remote DI stop inhibit
678	Remote DI stop inhibit reset
679	Comm stop inhibit
680	Comm stop inhibit reset
681	Forced stop inhibit
682	Forced stop inhibit reset
683	Anti backspin inhibit

Event code	Description
684	Anti backspin inhibit reset
685	Device internal error inhibit
686	Device internal error inhibit reset
687	Interlock time inhibit
688	Interlock time inhibit reset
689	Speed change inhibit
690	Speed change inhibit reset
691	Custom stop inhibit
692	Custom stop inhibit reset
693	Firmware update inhibit
694	Firmware update inhibit reset
695-768	Reserved

HMI Command Events

Event code	Description
769	HMI or DTM Start >
770	HMI or DTM start >>
771	HMI or DTM stop
772	HMI or DTM start <
773	HMI or DTM start <<
774	HMI or DTM trip reset
775	HMI or DTM inhibit reset (max starts)
776	HMI or DTM reset starts counter
777	HMI or DTM reset stops counter
778	HMI or DTM clear thermal memory
779	HMI or DTM reset total run hour
780	HMI or DTM reset energy
781	HMI or DTM forced start
782	HMI or DTM logic test input
783	HMI or DTM self test without trip
784	HMI or DTM self test with trip
785	HMI or DTM reset soft starter
786	HMI or DTM reset trip counter
787-792	Reserved
793	HMI or DTM reset network port setting
794	HMI or DTM reset all
795	HMI or DTM clear statistics
796	HMI or DTM reset protection setting
797	HMI or DTM save reference curve
798	HMI or DTM clear trip logs
799	HMI or DTM clear event logs
800	HMI or DTM factory reset

Communication Command Events

Event code	Description
801	COMM Start >
802	COMM Start >>
803	COMM Stop
804	COMM Start <
805	COMM Start <<
806	COMM Trip reset
807	COMMinhibit reset (max starts)
808	COMM Reset starts counter
809	COMM Reset stops counter
810	COMM Clear thermal memory
811	COMM Reset total run hour
812	COMM Reset energy
813	COMM Forced start
814	COMM Logic test input
815	COMM Self test without trip
816	COMMSelf test with trip
817	COMMReset soft starter
818	COMM Reset trip counter
819-824	Reserved
825	COMM Reset network port setting
826	COMM Reset all
827	COMM Clear statistics
828	COMM Reset protection settings
829	COMM Save reference curve
830	COMM Clear trip logs
831	COMM Clear event logs
832	COMM Factory reset
833	Permissive command 1
834	Permissive command 2
835	Permissive command 3
836	Permissive command 4
837	Permissive command 5
838	Permissive command 6
839	Permissive command 7
840	Permissive command 8
841-896	Reserved

Trip Reset Events

Event code	Description
897	Thermal overload trip reset
898	Locked rotor trip reset
899	Stalled rotor trip reset
900	Definite time overcurrent trip reset
901	Normal inverse overcurrent trip reset
902	Short time overcurrent trip reset
903	Calculated ground trip reset
904	Measured ground trip reset
905	Phase under current trip reset
906	Current imbalance trip reset
907	Current phase loss trip reset
908	Current phase reversal trip reset
909	Phase under voltage trip reset
910	Phase over voltage trip reset
911	Voltage phase loss trip reset
912	Voltage imbalance trip reset
913	Voltage phase reversal trip reset
914	Under frequency trip reset
915	Over frequency trip reset
916	Excessive start time trip reset
917	Communication loss trip reset
918	Over temperature trip reset
919	Under power trip reset
920	Over power trip reset
921	Under power factor trip reset
922	Reserved
923	Device internal trip reset
924	HMI communication loss trip reset
925-928	Reserved
929	Interlock 1 trip reset
930	Interlock 2 trip reset
931	Interlock 3 trip reset
932	Interlock 4 trip reset
933	Interlock 5 trip reset
934	Interlock 6 trip reset
935	Interlock 7 trip reset
936	Interlock 8 trip reset
937	Interlock 9 trip reset
938	Interlock 10 trip reset
939	Interlock 11 trip reset

Event code	Description
940	Interlock 12 trip reset
941-960	Reserved
961	AI1 trip reset
962	AI2 trip reset
963	AI3 trip reset
964	AI4 trip reset
965-991	Reserved
992	Logic test interrupted trip reset
993	Motor stop error detection trip reset
994-1024	Reserved

Digital Output

Event code	Description
1025	Device internal DO ON
1026	Device internal DO OFF
1027	Trip DO ON
1028	Trip DO OFF
1029	Alarm DO ON
1030	Alarm DO OFF
1031	Pickup DO ON
1032	Pickup DO OFF
1033	inhibit DO ON
1034	inhibit DO OFF
1035	Block OP DO ON
1036	Block OP DO OFF
1037	CNTR OP1 DO ON
1038	CNTR OP1 DO OFF
1039	CNTR OP2 DO ON
1040	CNTR OP2 DO OFF
1041	CNTR OP3 DO ON
1042	CNTR OP3 DO OFF
1043	CNTR OP4 DO ON
1044	CNTR OP4 DO OFF
1045	CNTR OP5 DO ON
1046	CNTR OP5 DO OFF
1047	CNTR OP6 DO ON
1048	CNTR OP6 DO OFF
1049-1152	Reserved

System and Control Events

Event code	Description
1153	Power down
1154	Power up
1155	Mode changed to Local1
1156	Mode changed to Local2
1157	Mode changed to Local3
1158	Mode changed to Remote
1159	Device internal error detected
1160	Self test without trip performed
1161	Self test with trip performed
1162	Logic test start
1163	Reset button OFF
1164	Reset button ON
1165	Reserved
1166	Date/Time updated
1167	Invalid start command
1168	Start error detected - No feedback
1169	Start error detected - Inhibit present
1170	Start error detected - Current or RUN DI feedback present
1171	Start error detected - No access
1172	Stop error detected - No access
1173	Logic test interrupted
1174	Communication loss detected
1175	Communication restored
1176	Mode shifted from Remote to Local1
1177	Auto restart
1178	Auto stopped
1179	Factory reset – test/reset key
1180	Bypass stop DI function disabled
1181	Bypass stop DI function enabled
1182	HMI Login Success
1183	HMI Login Error - Incorrect Pin
1184	HMI Logout Success
1185	HMI Logout - Session Timeout
1186	HMI Logout- Connection Lost
1187	DTM Login Success
1188	DTM Login Error - Incorrect Pin
1189	DTM Logout Success
1190	DTM Logout - Session Timeout
1191	DTM Logout- Connection Lost
1192	DTM New Pin Set
1193	DTM New Pin set Error - Invalid pin format

Event code	Description
1194	DTM Pin Change Success
1195	DTM Pin Change Error
1196	DTM Pin Change Error - Invalid pin format
1197	DTM Pin Reset Success
1198	DTM Pin Reset Error - Incorrect Pin
1199	COMM Login Success
1200	COMM Login Error – Incorrect Pin
1201	COMM Logout Success
1202	COMM Logout – Session Timeout
1203	COMM Logout – Connection Lost
1204	COMM New Pin Set
1205	COMM New Pin Set Error – Invalid pin format
1206	COMM Pin Change Success
1207	COMM Change Error – Incorrect Pin
1208	COMM Change Error – Invalid Format
1209	COMM Password Reset Success
1210	COMM Reset Error – Incorrect Pin
1211	Error - Pin not saved
1212	Error - Wrong LoginID
1213–1216	Reserved
1217	Custom Start >
1218	Custom Start >>
1219	Custom Stop
1220	Custom Start <
1221	Custom Start <<
1222	Start > Command Executed
1223	Start >> Command Executed
1224	Start < Command Executed
1225	Start << Command Executed
1226	Motor/Heater stopped
1227	Stop Cause - HMI
1228	Stop Cause - Local_DI
1229	Stop Cause - Remote_DI
1230	Stop Cause - Communication
1231	Stop Cause - Voltage Dip
1232	Stop Cause - Trip
1233	Stop Cause - No Current
1234	Stop Cause - Forced Stop
1235	Stop Cause - Change Direction
1236	Reserved
1237	Stop Cause - Change Speed
1238	Stop Cause - Custom Command
1239	Stop Cause - Mode Transfer

Event code	Description
1240	Reserved
1241	Stop Cause - No Voltage
1242–1280	Reserved
1281	DPV1 Start >
1282	DPV1 Start >>
1283	DPV1 Stop
1284	DPV1 Start <
1285	DPV1 Start <<
1286	DPV1 Trip reset
1287	DPV1 Inhibit reset (Max Starts)
1288	DPV1 Reset starts counter
1289	DPV1 Reset stops counter
1290	DPV1 Clear thermal memory
1291	DPV1 Reset total run hour
1292	DPV1 Reset energy
1293	DPV1 Forced start
1294	DPV1 Logic test
1295	DPV1 Self test without trip
1296	DPV1 Self test with trip
1297	DPV1 Reset soft starter
1298	DPV1 Reset trip counter
1299–1312	DPV1 Reserved
1313	DPV1 Permissive Command 1
1314	DPV1 Permissive Command 2
1315	DPV1 Permissive Command 3
1316	DPV1 Permissive Command 4
1317	DPV1 Permissive Command 5
1318	DPV1 Permissive Command 6
1319	DPV1 Permissive Command 7
1320	DPV1 Permissive Command 8
1321-1344	DPV1 Reserved
1345	LTMT main unit FW valid
1346	LTMT main unit invalid sign
1347	LTMT main unit incompatible ver
1348	LTMT main unit FW update success
1349–1360	Reserved
1361	LTMTCT/LTMTCTV sensor module FW valid
1362	LTMTCT/LTMTCTV sensor module invalid sign
1363	LTMTCT/LTMTCTV sensor module incompatible ver
1364	LTMTCT/LTMTCTV sensor module FW update success
1365	LTMTCT/LTMTCTV sensor module FW update timeout
1366–1376	Reserved
1377	LTMT expansion module FW valid
1378	LTMT expansion module invalid sign

Event code	Description
1379	LTMT expansion module incompatible ver
1380	LTMT expansion module FW update success
1381	LTMT expansion module FW update timeout
1382–1392	Reserved
1393	Device Configuration modified
1394	Modbus settings modified
1395	HMI settings modified
1396–1397	Reserved
1398	Starter settings modified
1399	System settings modified
1400	Motor Name Plate settings modified
1401	Session management settings modified
1402	Digital input settings modified
1403	Digital input settings modified
1404	Analog output settings modified
1405–1408	Reserved
1409	Thermal Overload protection setting modified
1410	Locked Rotor protection setting modified
1411	Stall Rotor protection setting modified
1412	Definite time overcurrent protection setting modified
1413	Normal inverse overcurrent protection setting modified
1414	Short time overcurrent protection setting modified
1415	Calculated ground trip protection setting modified
1416	Measured ground trip protection setting modified
1417	Under Current protection setting modified
1417	Current Imbalance protection setting modified
1419	Current Phase Loss protection setting modified
1420	Current Phase reversal protection setting modified
1421	Under Voltage protection setting modified
1422	Over Voltage protection setting modified
1423	Voltage Phase Loss protection setting modified
1424	Voltage Imbalance protection setting modified
1425	Voltage Phase reversal protection setting modified
1426	Under frequency protection setting modified
1427	Over frequency protection setting modified
1428	Excessive Start Time protection setting modified
1429	Communication loss protection setting modified
1430	Over Temperature protection setting modified
1431	Under Power protection setting modified
1432	Over Power protection setting modified
1433	Under Power Factor protection setting modified
1434	Reserved

Event code	Description
1435	Device Internal protection setting modified
1436	HMI Communication loss protection setting modified
1437–1440	Reserved
1441	Interlock 1 protection setting modified
1442	Interlock 2 protection setting modified
1443	Interlock 3 protection setting modified
1444	Interlock 4 protection setting modified
1445	Interlock 5 protection setting modified
1446	Interlock 6 protection setting modified
1447	Interlock 7 protection setting modified
1448	Interlock 8 protection setting modified
1449	Interlock 9 protection setting modified
1450	Interlock 10 protection setting modified
1451	Interlock 11 protection setting modified
1452	Interlock 12 protection setting modified
1453–1472	Reserved
1473	AI1 protection setting modified
1474	AI2 protection setting modified
1475	AI3 protection setting modified
1476	AI4 protection setting modified
1477–1503	Reserved
1504	Logic Test Interrupted protection setting modified
1505	Motor stop error detection protection setting modified
1506	Misc Hysteresis Settings Modified
1507	Voltage Dip Function Settings Modified
1508	Maximum number of Starts settings Modified
1509	Anti back spin settings modified
1510	Block out settings modified
1511–1536	Reserved

Device Internal Error Code

Detected internal error code	Description
1	Sensor module communication error detected
2	Sensor module communication error reset
3	LTMT expansion module communication error detected
4	LTMT expansion module communication error reset
5	HMI communication error detected
6	HMI communication error reset
7	EEPROM interface error detected
8	EEPROM interface error reset
9	EEPROM checksum error detected
10	EEPROM checksum error reset
11	Configuration error detected
12	Configuration error reset
13	PROFIBUS DP interface error detected
14	PROFIBUS DP interface error reset
15–16	Reserve
17	Main unit watchdog timeout detected
18	Main unit watchdog timeout error reset
19	Low Battery detected
20	Low Battery error reset
19–22	Reserved
23	LTMT main unit temperature input error detected
24	LTMT main unit temperature input error reset
25	Energy register overflow
26	Energy register overflow error reset
27	Error detected during LTMT expansion module initiation
28	LTMT expansion module initiation error reset
29	RTC initialization error detected
30	RTC initialization error reset
31	Reserved
32	Reserved
33–64	Reserved
65	LTMTCT/LTMTCTV sensor module watchdog timeout detected
66	LTMTCT/LTMTCTV sensor module watchdog timeout error reset
67	ADC conversion error detected
68	ADC conversion error reset
69	Flash error detected
70	Flash error reset
71	UART error detected
72	UART error reset
73	Voltage configuration not detected
74	Voltage configuration error reset
75–76	Reserved

Detected internal error code	Description
77	Calibration error detected
78	Calibration error reset
79	VL1 measurement error detected
80	VL1 measurement error reset
81	VL2 measurement error detected
82	VL2 measurement error reset
83	VL3 measurement error detected
84	VL3 measurement error reset
85	IL1 low gain measurement error detected
86	IL1 low gain measurement error reset
87	IL1 high gain measurement error detected
88	IL1 high gain measurement error reset
89	IL2 low gain measurement error detected
90	IL2 low gain measurement error reset
91	IL2 high gain measurement error detected
92	IL2 high gain measurement error reset
93	IL3 low gain measurement error detected
94	IL3 low gain measurement error reset
95	IL3 high gain measurement error detected
96	IL3 high gain measurement error reset
97–128	Reserved

Input Source

Index	Input source
0	None
1	Fixed 0
2	Fixed 1
3–6	Reserved
7	Reset_Key (Main Unit)
8	DI 1
9	DI 2
10	DI 3
11	DI 4
12	DI 5
13	DI 6
14	DI 7
15	DI 8
16	DI 9
17	DI 10
18	DI 11
19	DI 12
20	DI 13
21	DI 14
22	DI 15
23	DI 16
24	DI 17
25	DI 18
26	DI 19
27	DI 20
28	DI 21
29	DI 22
30	DI 23
31	DI 24
40	DO 1
41	DO 2
42	DO 3
43	DO 4
44	DO 5
45	DO 6
46	DO 7
47	DO 8
48	DO 9
49	DO 10
50	DO 11
51	DO 12
52	DO 13
53– 231	Reserved

Index	Input source
232	Pickup Status
233	Alarm Status
234	Trip Status
235	Motor Stop Error Detection
236	Reserved
237	Block Output
238–247	Reserved
248	Motor Stop
249	Motor Start
250	Motor Run
251	Motor Inhibit
252–263	Reserved
264	Thermal Overload Alarm
265	Locked Rotor Alarm
266	Stalled Rotor Alarm
267	Definite Time Overcurrent Alarm
268	Normal Inverse Overcurrent Alarm
269	Short Time Overcurrent Alarm
270	Calculated Ground Current Alarm
271	Measured Ground Current Alarm
272	Under Current Alarm
273	Current Imbalance Alarm
274	Current Phase Loss Alarm
275	Current Phase Reversal Alarm
276	Under Voltage Alarm
277	Over Voltage Alarm
278	Voltage Phase Loss Alarm
279	Voltage Imbalance Alarm
280	Voltage Phase Reversal Alarm
281	Under Frequency Alarm
282	Over Frequency Alarm
283	Reserved
284	Communication Loss Alarm
285	Over Temperature Alarm
286	Under Power Alarm
287	Over Power Alarm
288	Under Power Factor Alarm
289–295	Reserved
296	Thermal Overload Pickup
297	Locked Rotor Pickup
298	Stalled Rotor Pickup
299	Definite Time Overcurrent Pickup
300	Normal Inverse Overcurrent Pickup
301	Short Time Overcurrent Pickup

Index	Input source
302	Calculated Ground Current Pickup
303	Measured ground current Pickup
304	Under Current Pickup
305	Current Imbalance Pickup
306	Current Phase Loss Pickup
307	Current Phase Reversal Pickup
308	Under Voltage Pickup
309	Over Voltage Pickup
310	Voltage Phase Loss Pickup
311	Voltage Imbalance Pickup
312	Voltage Phase Reversal Pickup
313	Under Frequency Pickup
314	Over Frequency Pickup
315	Excessive Start Time Pickup
316	Communication Loss Pickup
317	Over Temperature Pickup
318	Under Power Pickup
319	Over Power Pickup
320	Under Power Factor Pickup
321	Reserved
328	Thermal Overload Trip
329	Locked Rotor Trip
330	Stalled Rotor Trip
331	Definite Time Overcurrent Trip
332	Normal Inverse Overcurrent Trip
333	Short Time Overcurrent Trip
334	Calculated Ground Current Trip
335	Measured Ground Current Trip
336	Under Current Trip
337	Current Imbalance Trip
338	Current Phase Loss Trip
339	Current Phase Reversal Trip
340	Under Voltage Trip
341	Over Voltage Trip
342	Voltage Phase Loss Trip
343	Voltage Imbalance Trip
344	Voltage Phase Reversal Trip
345	Under Frequency Trip
346	Over Frequency Trip
347	Excessive Start Time Trip
348	Communication Loss Trip
349	Over Temperature Trip

Index	Input source
350	Under Power Trip
351	Over Power Trip
352	Under Power factor Trip
353–359	Reserved
360	Interlock 1 Alarm
361	Interlock 2 Alarm
362	Interlock 3 Alarm
363	Interlock 4 Alarm
364	Interlock 5 Alarm
365	Interlock 6 Alarm
366	Interlock 7 Alarm
367	Interlock 8 Alarm
368	Interlock 9 Alarm
369	Interlock 10 Alarm
370	Interlock 11 Alarm
371	Interlock 12 Alarm
372–375	Reserved
376	Interlock 1 Pickup
377	Interlock 2 Pickup
378	Interlock 3 Pickup
379	Interlock 4 Pickup
380	Interlock 5 Pickup
381	Interlock 6 Pickup
382	Interlock 7 Pickup
383	Interlock 8 Pickup
384	Interlock 9 Pickup
385	Interlock 10 Pickup
386	Interlock 11 Pickup
387	Interlock 12 Pickup
388–391	Reserved
392	Interlock 1 Trip
393	Interlock 2 Trip
394	Interlock 3 Trip
395	Interlock 4 Trip
396	Interlock 5 Trip
397	Interlock 6 Trip
398	Interlock 7 Trip
399	Interlock 8 Trip
400	Interlock 9 Trip
401	Interlock 10 Trip
402	Interlock 11 Trip
403	Interlock 12 Trip
404–503	Reserved
504	Contactor Output 1

Index	Input source
505	Contacteur Output 2
506	Contacteur Output 3
507	Contacteur Output 4
508	Contacteur Output 5
509–535	Reserved
536	Motor Forward Running
537	Motor Reverse Running
538	Motor Fast Forward Running
539	Motor Fast Reverse Running
540	Motor Running in Star (Forward)
541	Motor Running in Delta (Forward)
542	Motor Running in Star (Reverse)
543	Motor Running in Delta (Reverse)
544	Motor in Star-Delta Changeover (Forward)
545	Motor in Star-Delta Changeover (Reverse)
546	Interlocking Time Active
547	Change-Over Pause Active
548–551	Reserved
552	Status - Permissive Command 1
553	Status - Permissive Command 2
554	Status - Permissive Command 3
555	Status - Permissive Command 4
556	Status - Permissive Command 5
557	Status - Permissive Command 6
558	Status - Permissive Command 7
559	Status - Permissive Command 8
560–583	Reserved
584	No Voltage Inhibit
585	Under Voltage Inhibit
586	Trip Inhibit
587	Thermal Inhibit
588	Max Starts Inhibit
589	Interlock 1 Inhibit
590	Interlock 2 Inhibit
591	Interlock 3 Inhibit
592	Interlock 4 Inhibit
593	Interlock 5 Inhibit
594	Interlock 6 Inhibit
595	Interlock 7 Inhibit
596	Interlock 8 Inhibit
597	Interlock 9 Inhibit
598	Interlock 10 Inhibit
599	Interlock 11 Inhibit
600	Interlock 12 Inhibit

Index	Input source
601	Local DI Stop Inhibit
602	Remote DI Stop Inhibit
603	Communication Stop Inhibit
604	Forced Stop Inhibit
605	Antibackspin Inhibit
606	Reserved
607	Direction Change Inhibit
608	Speed Change Inhibit
609	Custom Stop Inhibit
610–615	Reserved
616	Sensor Module Communication Error Detected
617	LTMT expansion module Communication Error Detected
618	HMI Communication Error Detected
619	EEPROM Interface Error Detected
620	EEPROM Checksum Error Detected
621	Configuration Error Detected
622	PROFIBUS DP Interface Error Detected
623	Reserved
624	Watchdog Timeout Detected
625–627	Reserved
628	Energy Register Overflow
629	Error Detected during LTMT expansion module Initialization
630–647	Reserved
648	Watchdog Timeout Detected
649	ADC Conversion Error Detected
650	Flash Error Detected
651	Reserved
652	Voltage Configuration Not Detected
653	Reserved
654	Calibration Error Detected
655	VL1 Measurement Error Detected
656	VL2 Measurement Error Detected
657	VL3 Measurement Error Detected
658	IL1 Low Gain Measurement Error Detected
659	IL1 High Gain Measurement Error Detected
660	IL2 Low Gain Measurement Error Detected
661	IL2 High Gain Measurement Error Detected
662	IL3 Low Gain Measurement Error Detected
663	IL3 High Gain Measurement Error Detected
664–65534	Reserved
65535	Custom Logic

Schneider Electric Industries SAS
35 rue Joseph Monier
92500 Rueil Malmaison
France

www.se.com

As standards, specifications, and design change from time to time, please ask for confirmation of the information given in this publication.

© 2025 – Schneider Electric . All rights reserved.

DOCA0257EN-01