

Lexium 52

Hardware Guide

(Original Document)

04/2018

EIO0000001347.05

www.schneider-electric.com



The information provided in this documentation contains general descriptions and/or technical characteristics of the performance of the products contained herein. This documentation is not intended as a substitute for and is not to be used for determining suitability or reliability of these products for specific user applications. It is the duty of any such user or integrator to perform the appropriate and complete risk analysis, evaluation and testing of the products with respect to the relevant specific application or use thereof. Neither Schneider Electric nor any of its affiliates or subsidiaries shall be responsible or liable for misuse of the information contained herein. If you have any suggestions for improvements or amendments or have found errors in this publication, please notify us.

You agree not to reproduce, other than for your own personal, noncommercial use, all or part of this document on any medium whatsoever without permission of Schneider Electric, given in writing. You also agree not to establish any hypertext links to this document or its content. Schneider Electric does not grant any right or license for the personal and noncommercial use of the document or its content, except for a non-exclusive license to consult it on an "as is" basis, at your own risk. All other rights are reserved.

All pertinent state, regional, and local safety regulations must be observed when installing and using this product. For reasons of safety and to help ensure compliance with documented system data, only the manufacturer should perform repairs to components.

When devices are used for applications with technical safety requirements, the relevant instructions must be followed.

Failure to use Schneider Electric software or approved software with our hardware products may result in injury, harm, or improper operating results.

Failure to observe this information can result in injury or equipment damage.

© 2018 Schneider Electric. All Rights Reserved.

Table of Contents



	Safety Information	7
	About the Book	9
Chapter 1	Specific Safety Information	13
	Product Related Information	14
	Proper Use	19
	Qualification of Personnel	21
Chapter 2	System Overview	23
	System Overview	24
	Logic Motion Controller	25
	Lexium 52	26
	Lexium SH3 Servo Motor	27
	Lexium MH3 Servo Motor	28
	Type Code	29
	Nameplate Descriptions	30
Chapter 3	Planning	33
3.1	Electromagnetic Compatibility, EMC	34
	Electromagnetic Compatibility, EMC	34
3.2	Control Cabinet Planning	39
	Degree of Protection (IP)	40
	Mechanical and Climatic Environmental Conditions in the Control Cabinet	41
	Using Cooling Units	42
3.3	Information about Wiring	44
	General Information about Wiring	45
	Cable Characteristics	46
	Cable Assembly	47
	ESD Protection Measures	47
	Conditions for UL Compliant Use	48
	Fusing the Mains Connection	49
	Mains Contactor	50
	Mains Filter	50
	Mains Line Reactor (Choke)	51

	Leakage (Touch) Current	52
	Residual Current Operated Protective Device	53
	Parallel Connection DC Bus	55
	Shield Connection	60
3.4	Functional Safety	61
	Process Minimizing Risks Associated with the Machine	62
	Inverter Enable Function	64
	Setup, Installation and Maintenance	69
	Application Proposals	70
	Commissioning	73
	Best Practices	74
	Maintenance	76
	Physical Environment	77
	Safety Standards	78
3.5	Special Conditions	79
	Low Air Pressure	79
Chapter 4	Installation and Maintenance	81
4.1	Commissioning	82
	Prerequisites for Commissioning	83
	Preparing Commissioning	84
	Preparing the Control Cabinet	86
	Mechanical Mounting	91
	Motor Cable and External Shield Connection	92
4.2	Maintenance, Repair, Cleaning, Replacement Equipment Inventory	93
	Prerequisites for Maintenance, Repair, and Cleaning	94
	Machine Repair	96
	Cleaning	98
	Replacement Equipment Inventory	98
4.3	Replacing Components and Cables	99
	Prerequisites for Replacing Components and Cables	100
	Component Replacement	103
	Cable Replacement	105
Chapter 5	Indicators and Control Elements	107
	Indicators and Control Elements	107
Chapter 6	Integrated Communication Ports	111
	Electrical Connections Overview	112
	Connection Details	115

Chapter 7	Technical Data	123
	Ambient Conditions	124
	Standards and Regulations	125
	Mechanical and Electrical Data	126
	Dimensions	131
Appendices	133
Appendix A	Further Information on the Manufacturer	135
	Contact Addresses	136
	Product Training Courses	136
Appendix B	Disposal	137
	Disposal	137
Appendix C	Optional Accessory	139
C.1	5V Encoder Adapter	140
	Overview	141
	Technical Data	142
	Electrical Connections and Dimensions	143
	Wiring	146
Appendix D	Units and Conversion Tables	147
	Units and Conversion Tables	147
Index	151

Safety Information



Important Information

NOTICE

Read these instructions carefully, and look at the equipment to become familiar with the device before trying to install, operate, service, or maintain it. The following special messages may appear throughout this documentation or on the equipment to warn of potential hazards or to call attention to information that clarifies or simplifies a procedure.



The addition of this symbol to a “Danger” or “Warning” safety label indicates that an electrical hazard exists which will result in personal injury if the instructions are not followed.



This is the safety alert symbol. It is used to alert you to potential personal injury hazards. Obey all safety messages that follow this symbol to avoid possible injury or death.

DANGER

DANGER indicates a hazardous situation which, if not avoided, **will result in death** or serious injury.

WARNING

WARNING indicates a hazardous situation which, if not avoided, **could result in death** or serious injury.

CAUTION

CAUTION indicates a hazardous situation which, if not avoided, **could result** in minor or moderate injury.

NOTICE

NOTICE is used to address practices not related to physical injury.

PLEASE NOTE

Electrical equipment should be installed, operated, serviced, and maintained only by qualified personnel. No responsibility is assumed by Schneider Electric for any consequences arising out of the use of this material.

A qualified person is one who has skills and knowledge related to the construction and operation of electrical equipment and its installation, and has received safety training to recognize and avoid the hazards involved.

About the Book



At a Glance

Document Scope

Read and understand the material contained in this manual before you work on the Lexium 52 for the first time. Take particular note of the chapter Specific Safety Information (*see page 14*). Only those persons who meet the criteria described in Qualification of Personnel (*see page 21*) are allowed to work with the Lexium 52.

A copy of this manual must be available for personnel who work with the Lexium 52.

This manual is to help you use the capabilities of the Lexium 52 safely and properly.

Follow the instructions within this manual to help:

- Reduce risks
- Reduce repair costs and downtime of the Lexium 52
- Increase the service life of the Lexium 52
- Increase reliability of the Lexium 52

Validity Note

This document has been updated with the release of SoMachine Motion V4.4 SP1.

The technical characteristics of the devices described in the present document also appear online. To access the information online:

Step	Action
1	Go to the Schneider Electric home page www.schneider-electric.com .
2	In the Search box type the reference of a product or the name of a product range. <ul style="list-style-type: none">● Do not include blank spaces in the reference or product range.● To get information on grouping similar modules, use asterisks (*).
3	If you entered a reference, go to the Product Datasheets search results and click on the reference that interests you. If you entered the name of a product range, go to the Product Ranges search results and click on the product range that interests you.
4	If more than one reference appears in the Products search results, click on the reference that interests you.
5	Depending on the size of your screen, you may need to scroll down to see the data sheet.
6	To save or print a data sheet as a .pdf file, click Download XXX product datasheet .

The characteristics that are presented in the present document should be the same as those characteristics that appear online. In line with our policy of constant improvement, we may revise content over time to improve clarity and accuracy. If you see a difference between the document and online information, use the online information as your reference.

Terminology Derived from Standards

The technical terms, terminology, symbols and the corresponding descriptions in this manual, or that appear in or on the products themselves, are generally derived from the terms or definitions of international standards.

In the area of functional safety systems, drives and general automation, this may include, but is not limited to, terms such as *safety*, *safety function*, *safe state*, *fault*, *fault reset*, *malfunction*, *failure*, *error*, *error message*, *dangerous*, etc.

Among others, these standards include:

Standard	Description
EN 61131-2:2007	Programmable controllers, part 2: Equipment requirements and tests.
ISO 13849-1:2008	Safety of machinery: Safety related parts of control systems. General principles for design.
EN 61496-1:2013	Safety of machinery: Electro-sensitive protective equipment. Part 1: General requirements and tests.
ISO 12100:2010	Safety of machinery - General principles for design - Risk assessment and risk reduction
EN 60204-1:2006	Safety of machinery - Electrical equipment of machines - Part 1: General requirements
EN 1088:2008 ISO 14119:2013	Safety of machinery - Interlocking devices associated with guards - Principles for design and selection
ISO 13850:2006	Safety of machinery - Emergency stop - Principles for design
EN/IEC 62061:2005	Safety of machinery - Functional safety of safety-related electrical, electronic, and electronic programmable control systems
IEC 61508-1:2010	Functional safety of electrical/electronic/programmable electronic safety-related systems: General requirements.
IEC 61508-2:2010	Functional safety of electrical/electronic/programmable electronic safety-related systems: Requirements for electrical/electronic/programmable electronic safety-related systems.
IEC 61508-3:2010	Functional safety of electrical/electronic/programmable electronic safety-related systems: Software requirements.
IEC 61784-3:2008	Digital data communication for measurement and control: Functional safety field buses.
2006/42/EC	Machinery Directive
2014/30/EU	Electromagnetic Compatibility Directive
2014/35/EU	Low Voltage Directive

In addition, terms used in the present document may tangentially be used as they are derived from other standards such as:

Standard	Description
IEC 60034 series	Rotating electrical machines
IEC 61800 series	Adjustable speed electrical power drive systems
IEC 61158 series	Digital data communications for measurement and control – Fieldbus for use in industrial control systems

Finally, the term *zone of operation* may be used in conjunction with the description of specific hazards, and is defined as it is for a *hazard zone* or *danger zone* in the *Machinery Directive (2006/42/EC)* and *ISO 12100:2010*.

NOTE: The aforementioned standards may or may not apply to the specific products cited in the present documentation. For more information concerning the individual standards applicable to the products described herein, see the characteristics tables for those product references.

Chapter 1

Specific Safety Information

Overview

This chapter contains important safety information regarding working with the Lexium 52. The Lexium 52 Drive System conforms to recognized technical safety regulations.

What Is in This Chapter?

This chapter contains the following topics:

Topic	Page
Product Related Information	14
Proper Use	19
Qualification of Personnel	21

Product Related Information

Overview

Health and safety risks arising from the Lexium 52 have been reduced. However a residual risk remains, since the Lexium 52 works with electrical voltage and electrical currents.

If activities involve residual risks, a safety message is made at the appropriate points. This includes potential hazard(s) that may arise, their possible consequences, and describes preventive measures to avoid the hazard(s).

Electrical Parts

DANGER

ELECTRIC SHOCK, EXPLOSION, OR ARC FLASH

- Disconnect all power from all equipment including connected devices prior to removing any covers or doors, or installing or removing any accessories, hardware, cables, or wires.
- Place a "Do Not Turn On" or equivalent hazard label on all power switches and lock them in the non-energized position.
- Wait 15 minutes to allow the residual energy of the DC bus capacitors to discharge.
- Measure the voltage on the DC bus with a properly rated voltage sensing device and verify that the voltage is less than 42.4 Vdc.
- Do not assume that the DC bus is voltage-free when the DC bus LED is off.
- Block the motor shaft to prevent rotation prior to performing any type of work on the drive system.
- Do not create a short-circuit across the DC bus terminals or the DC bus capacitors.
- Replace and secure all covers, accessories, hardware, cables, and wires and confirm that a proper ground connection exists before applying power to the unit.
- Use only the specified voltage when operating this equipment and any associated products.

Failure to follow these instructions will result in death or serious injury.

⚠ DANGER**ELECTRIC SHOCK, EXPLOSION, OR ARC FLASH**

- Operate electrical components only with a connected protective ground (earth) cable.
- After the installation, verify the secure connection of the protective ground (earth) cable to all electrical devices to ensure that connection complies with the connection diagram.
- Before enabling the device, safely cover the live components to prevent contact.
- Do not touch the electrical connection points of the components when the module is energized.
- Provide protection against indirect contact (EN 50178).
- Connect and disconnect cables and terminals only after you have verified that the power has been removed from the system.
- Insulate the unused conductors on both ends of the motor cable.

Failure to follow these instructions will result in death or serious injury.

Assembly and Handling

This product has a leakage (touch) current greater than 3.5 mA. If the protective ground connection is interrupted, a hazardous leakage (touch) current may flow if the housing is touched.

⚠ DANGER**INSUFFICIENT GROUNDING**

- Use a protective ground conductor with at least 10 mm² (AWG 6) or two protective ground conductors with the same or larger cross section of the conductors supplying the power terminals.
- Verify compliance with all local and national electrical code requirements as well as all other applicable regulations with respect to grounding of all equipment.

Failure to follow these instructions will result in death or serious injury.

⚠ WARNING**CRUSHING, SHEARING, CUTTING AND HITTING DURING HANDLING**

- Observe the general construction and safety regulations for handling and assembly.
- Use appropriate mounting and transport equipment and use appropriate tools.
- Prevent clamping and crushing by taking appropriate precautions.
- Cover edges and angles to protect against cutting damage.
- Wear appropriate protective clothing (for example, protective goggles, protective boots, protective gloves).

Failure to follow these instructions can result in death, serious injury, or equipment damage.

Hot Surfaces

The metal surfaces of the product may exceed 65 °C (149 °F) (for bare metal) during operation.

WARNING

HOT SURFACES

- Avoid unprotected contact with hot surfaces.
- Do not allow flammable or heat-sensitive parts in the immediate vicinity of hot surfaces.
- Verify that the heat dissipation is sufficient by performing a test run under maximum load conditions.

Failure to follow these instructions can result in death, serious injury, or equipment damage.

Magnetic and Electromagnetic Fields

Conductors and motors can generate strong local electrical and magnetic fields. This can cause interference in sensitive devices.

WARNING

ELECTROMAGNETIC FIELDS

- Keep persons with electronic medical implants, such as pacemakers, away from the motor and the conductors.
- Do not place electromagnetically sensitive devices in the vicinity of the motor or of the conductors.

Failure to follow these instructions can result in death, serious injury, or equipment damage.

Hazardous Movements

There can be different sources of hazardous movements:

- No, or incorrect, homing of the drive
- Wiring or cabling errors
- Errors in the application program
- Component errors
- Error in the measured value and signal transmitter

NOTE: Provide for personal safety by primary equipment monitoring or measures. Do not rely only on the internal monitoring of the drive components. Adapt the monitoring or other arrangements and measures to the specific conditions of the installation in accordance with a risk and error analysis.

 **DANGER****UNAVAILABLE OR INADEQUATE PROTECTION DEVICE(S)**

- Prevent entry to a zone of operation with, for example, protective fencing, mesh guards, protective coverings, or light barriers.
- Dimension the protective devices properly and do not remove them.
- Do not make any modifications that can degrade, incapacitate, or in any way invalidate protection devices.
- Before accessing the drives or entering the zone of operation, bring the drives and the motors they control to a stop.
- Protect existing workstations and operating terminals against unauthorized operation.
- Position EMERGENCY STOP switches so that they are easily accessible and can be reached quickly.
- Validate the functionality of EMERGENCY STOP equipment before start-up and during maintenance periods.
- Prevent unintentional start-up by disconnecting the power connection of the drive using the EMERGENCY STOP circuit or using an appropriate lock-out tag-out sequence.
- Validate the system and installation before the initial start-up.
- Avoid operating high-frequency, remote control, and radio devices close to the system electronics and their feed lines, and perform, if necessary, an EMC validation of the system.

Failure to follow these instructions will result in death or serious injury.

Drive systems may perform unanticipated movements because of incorrect wiring, incorrect settings, incorrect data or other errors.

 **WARNING****UNINTENDED MOVEMENT OR MACHINE OPERATION**

- Carefully install the wiring in accordance with the EMC requirements.
- Do not operate the product with undetermined settings and data.
- Perform comprehensive commissioning tests that include verification of configuration settings and data that determine position and movement.

Failure to follow these instructions can result in death, serious injury, or equipment damage.

PELV Circuits

The signal voltage and the control voltage of the devices are less than 30 Vdc and have to be designed as PELV (Protective Extra Low Voltage) circuits. In this range, the specification as PELV system, according to IEC 61800-5-1 requires a protective measure against direct and indirect contact with hazardous voltage through an implemented separation in the system/machine of the primary and the secondary side. Separate high and low voltage wiring and respect the standard IEC 61800-5-1, Adjustable speed electrical power drive systems - safety requirements.

DANGER

ELECTRIC SHOCK BY INADEQUATE PROTECTIVE SEPARATION

Only connect devices, electrical components, or lines to the signal voltage connectors of these products that feature a sufficient, protective separation from the connected circuits in accordance with the standards (IEC 61800-5-1: Adjustable speed electrical power drive systems - safety requirements).

Failure to follow these instructions will result in death or serious injury.

NOTE: Use secondary isolating source rated 30 Vdc. Fuse in accordance with CSA-C22.2 No. 248, rated maximum 3 A must be connected between the source and the contacts.

Proper Use

Installation

Install and operate this equipment in an enclosure appropriately rated for its intended environment and secured by a keyed or tooled locking mechanism.

Provide for Protective Measures

Before installing the device, provide for appropriate protective devices in compliance with local and national standards. Do not commission components without appropriate protective devices. After installation, commissioning, or repair, test the protective devices used.

Perform a risk evaluation concerning the specific use before operating the product and take appropriate security measures.

WARNING

UNINTENDED EQUIPMENT OPERATION

Ensure that a risk assessment is conducted and respected according to EN/ISO 12100 during the design of your machine.

Failure to follow these instructions can result in death, serious injury, or equipment damage.

If circumstances occur that affect the safety or cause changes to the operating behavior of the Lexium 52, then immediately shut down the Lexium 52 and contact your Schneider Electric representative.

Use Original Equipment Only

Use only the accessories and mounting parts specified in the documentation and no third-party devices or components that have not been expressly approved by Schneider Electric.

WARNING

UNINTENDED EQUIPMENT OPERATION

- Only use software and hardware components approved by Schneider Electric for use with this equipment.
- Do not attempt to service this equipment outside of authorized Schneider Electric service centers.
- Update your application program every time you change the physical hardware configuration.

Failure to follow these instructions can result in death, serious injury, or equipment damage.

Environment Restrictions

The components must not be used in the following environments:

- In hazardous (explosive) atmospheres
- In mobile, movable, or floating systems
- In life support systems
- In domestic appliances
- Underground

This equipment has been designed to operate outside of any hazardous location. Only install this equipment in zones known to be free of a hazardous atmosphere.

 **DANGER**

POTENTIAL FOR EXPLOSION

Install and use this equipment in non-hazardous locations only.

Failure to follow these instructions will result in death or serious injury.

Qualification of Personnel

Target Audience for This Manual

Electrical equipment must be installed, operated, serviced, and maintained only by qualified personnel. No responsibility is assumed by Schneider Electric for any consequences arising out of the use of this material.

Qualified Person

A qualified person is one who has skills and knowledge related to the construction and operation of electrical equipment and the installation, and has received safety training to recognize and avoid the hazards involved.

The qualified personnel must be able to detect possible hazards that may arise from parameterization, changing parameter values and generally from mechanical, electrical, or electronic equipment. The qualified personnel must be familiar with the standards, provisions, and regulations for the prevention of industrial accidents, which they must observe when working on the drive system.

Designated Safety Functions

Qualified personnel that work with designated safety functions must be trained according to the complexity of the machines and the requirements of the EN ISO 13849-1:2008. The training has to include the production process and the relation between the designated safety function and the machine.

Qualification guidelines are available in the following publication: *Safety, Competency and Commitment: Competency Guidelines for Safety-Related System Practitioners*. IEEE Publications, ISBN 0 85296 787 X, 1999.

Chapter 2

System Overview

What Is in This Chapter?

This chapter contains the following topics:

Topic	Page
System Overview	24
Logic Motion Controller	25
Lexium 52	26
Lexium SH3 Servo Motor	27
Lexium MH3 Servo Motor	28
Type Code	29
Nameplate Descriptions	30

System Overview

System Overview

The control system consists of several components, depending on its application.

PacDrive 3 system overview

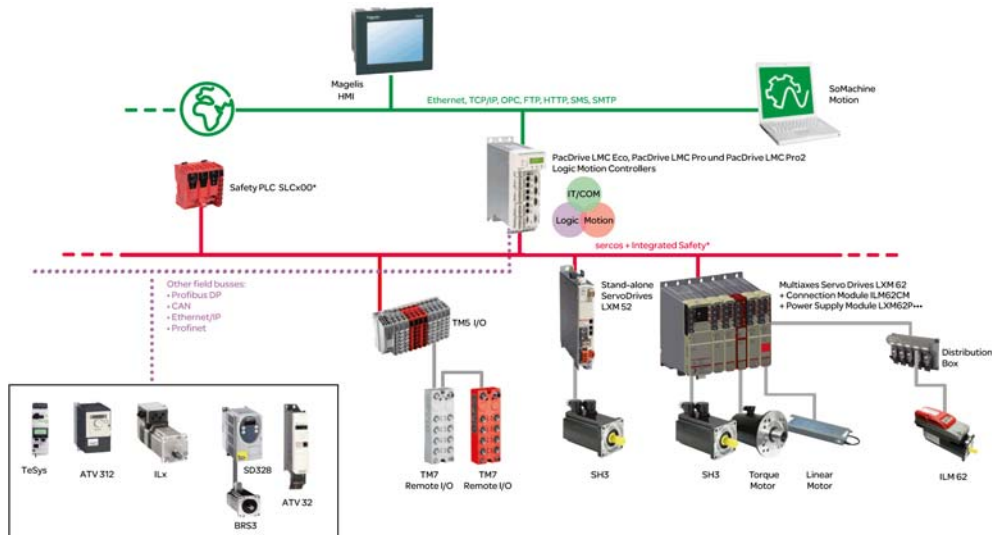

* Safety Logic Controller according to IEC 61508:2010 and EN ISO 13849:2008

Logic Motion Controller

Overview

Product	Description
	<p>The PacDrive LMC (Logic Motion Controller), with a VxWorks real-time operating system, centrally implements the Logic Controller and motion functions. A PacDrive LMC synchronizes, coordinates, and creates the motion functions of a machine for a maximum of:</p> <ul style="list-style-type: none">● 0 Sercos servo drives for the controller PacDrive LMC100● 4 Sercos servo drives for the controller PacDrive LMC101● 6 Sercos servo drives for the controller PacDrive LMC106● 8 Sercos servo drives for the controller PacDrive LMC201● 12 Sercos servo drives for the controller PacDrive LMC212● 16 Sercos servo drives for the controller PacDrive LMC216● 8 Sercos servo drives for the controller PacDrive LMC300● 16 Sercos servo drives for the controller PacDrive LMC400● 16 Sercos servo drives for the controller PacDrive LMC402● 99 Sercos servo drives for the controller PacDrive LMC600● 130 Sercos servo drives for the controller PacDrive LMC802

Lexium 52

Overview

Product	Description
	<p>The stand-alone Lexium 52 Sercos servo amplifier is designed for servo drive solutions with independent single axes, or other applications involving asynchronous motors.</p> <p>The power electronic components of the Lexium 52 are fitted inside the control cabinet.</p> <p>The drive provides the phase currents required for the position control of the connected motors. According to the different requirements in relation to the individual servo axes of the application, the Lexium 52 is available in different current classes.</p> <p>The Lexium 52 helps simplify the wiring in relation to the initial start-up and service cases. This also applies to the cable connection of the enclosed devices to the field. All the connectors that can be connected from the outside (power input, DC bus, 24 Vdc supply, Sercos, motor, encoder, I/Os, I/O supply, Ready and Inverter Enable (STO)) are designed so that a fast, simple configuration on the device can be realized.</p>

Lexium SH3 Servo Motor

Overview

Product	Description
	The servo motors meet rigorous requirements of dynamics and precision. Five flange sizes with different torque outputs offer the correct drive solution for your application.

High Dynamic AC Servo Motors

Because of the low inertia and a high overload capability, the motor Lexium SH3 fulfills the requirements concerning the accuracy, dynamics, and efficiency.

The Lexium SH3 motors are available in five different flange sizes:

- SH3-055
- SH3-070
- SH3-100
- SH3-140
- SH3-205

The highlights:

- Developed for high dynamics and precision
- Single tooth winding
- Compact size
- High-power density
- Low internal moment of inertia
- High overload capability
- Low detent torque

Lexium MH3 Servo Motor

Overview

Product	Description
	Lexium MH3 servo motors provide excellent power density values to meet the requirements of compact machines.

Dynamic AC Servo Motors

With four flange sizes and three different lengths for each flange size, they are suitable for many applications, covering a continuous stall range from 1.4 to 65 Nm (1.0 to 47.9 lbf ft) for speeds up to 6000 rpm. The Lexium MH3 servo motors have a medium inertia motor, which means they are particularly suitable for high-load applications. They help to simplify installation and adjustment by providing robust adjustment of the movement.

The Lexium MH3 servo motors are available in four flange sizes:

- MH3-070 (70 mm / 2.76 in.)
- MH3-100 (100 mm / 3.94 in.)
- MH3-140 (140 mm / 5.51 in.)
- MH3-190 (190 mm / 7.48 in.)

Type Code

Overview

The graphic shows the type code Lexium 52:

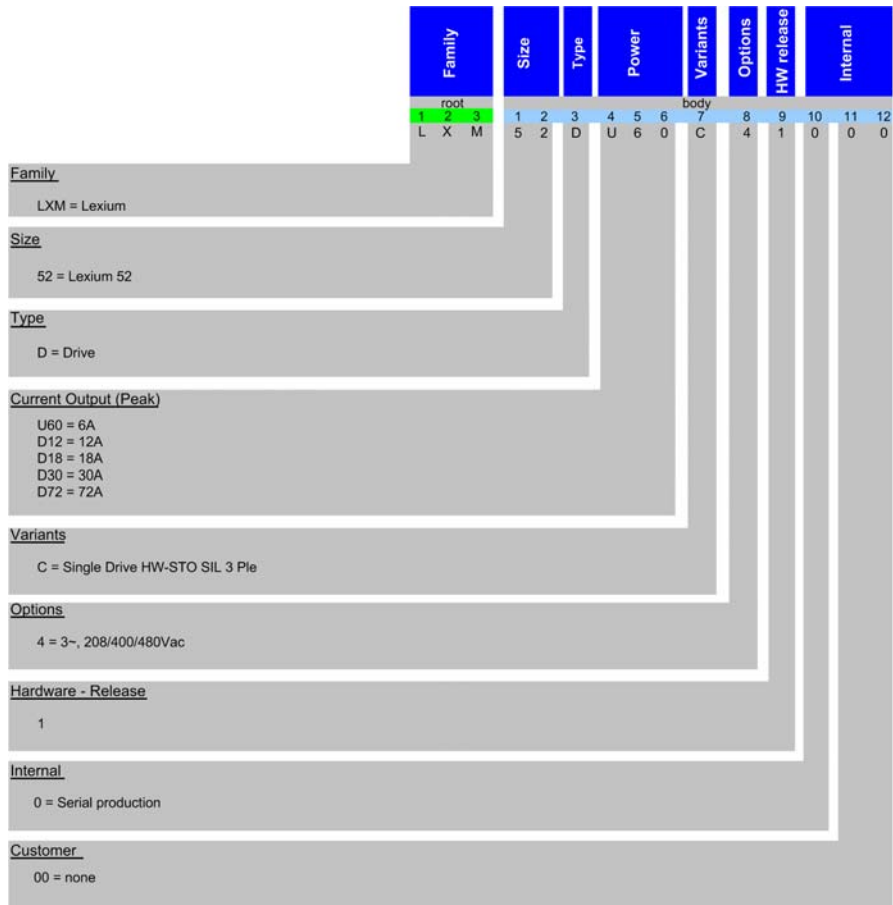

Nameplate Descriptions

Overview

The technical nameplates are located laterally on the housing:



Explanation of the technical nameplate entries:

Label	Description
LXM52xxxxxxxx	Device type and Unicode
Input AC	Input voltage and input current (rated and peak value per input)
Output	Output voltage and output current (rated and peak value per output)
IP20	Degree of protection
RS:01	Hardware revision ⁽¹⁾
D.O.M.	Date of manufacture in day-month-year format
(1) When replacing the device, the hardware revision for the previous and the new device should be identical to help avoid potential compatibility issues with the equipment.	

The logistical nameplate is located on top of the housing.

LXM52DD18C41000

Chapter 3

Planning

What Is in This Chapter?

This chapter contains the following sections:

Section	Topic	Page
3.1	Electromagnetic Compatibility, EMC	34
3.2	Control Cabinet Planning	39
3.3	Information about Wiring	44
3.4	Functional Safety	61
3.5	Special Conditions	79

Section 3.1

Electromagnetic Compatibility, EMC

Electromagnetic Compatibility, EMC

Electromagnetic Disturbances of Signals and Devices

This product meets the EMC requirements in accordance with the standard IEC 61800-3:2004, provided that the EMC measures described in this manual are complied with during installation.

 WARNING
--

ELECTROMAGNETIC DISTURBANCES OF SIGNALS AND DEVICES
--

Use proper EMC shielding techniques to help prevent unintended device operation in accordance with the standard IEC 61800-3.
--

Failure to follow these instructions can result in death, serious injury, or equipment damage.

These types of devices are not intended to be used on a low-voltage public network which supplies domestic premises. Radio frequency interference is expected if used in such a network.

 WARNING
--

RADIO INTERFERENCE

Do not use these products in domestic electrical networks.
--

Failure to follow these instructions can result in death, serious injury, or equipment damage.

Drive Operation via DC Bus

If drives are to be operated via a common DC bus, the following aspects must be considered in terms of EMC:

- Keep DC bus cables as short as possible.
- Shielded DC bus cables must be used at a cable length of > 20 cm (7.87 in).
In the case of shielded DC bus cables, connect the cable shield to the shield connection (large surface area contact).

Enclosure Layout

The prerequisite for compliance with the specified limit values is an EMC compatible layout. Depending on the application, the following measures can improve the EMC-dependent values:

EMC measures	Objective
Use galvanized or chromium-plated sub plates, bond metallic parts across large surface areas, remove paint layer from contact surfaces.	Good conductivity by surface area contact.
Ground enclosure, door, and sub plates by using grounding strips or grounding cables with a cross-section of 10 mm ² (AWG 6).	Reduce emission.
Supplement switch devices such as contactors, relays, or magnetic valves with interference suppression combinations or spark suppressor elements (for example, diodes, varistors, RC elements).	Reduces mutual interference.
Fit power and control components separately.	Reduces mutual interference.

Shielded Cables

EMC measures	Objective
Place cable shields on the surface, use cable clamps and grounding strips.	Reduce emission.
Ground shields of digital signal cables on both sides across large surface areas or through conducting connector housings.	Reduce interference action on signal cables, reduce emissions.
Ground shield of analog signal cables directly on the device (signal input), insulate the shield at the other cable end or ground the same through a capacitor, such as 10 nF.	Reduce grounding loops by low frequency interferences.

Cable Routing

EMC measures	Objective
Do not route fieldbus cables and signal cables together with cabling for direct and alternating voltages above 60 V in the same cable duct (fieldbus cables can be routed together with signal cables and analog cables in the same duct). Electromagnetic immunity will improve by routing cables in separated cable ducts with a distance of at least 20 cm (7.84 in).	Reduces mutual interference.

EMC measures	Objective
Keep the cables as short as possible. Do not install any unnecessary cable loops, short cable routing from a central grounding point in the control cabinet to the external grounding connection.	Reduce capacitive and inductive interference couplings.
Insert a potential equalization for: <ul style="list-style-type: none"> ● Large surface installation ● Different voltage infeeds ● Networking across buildings 	Reduce current on cable shield, reduce emissions.
Use fine wire potential equalization conductor.	Discharging of high frequency interference currents.
If motor and machine are not connected in a conducting fashion, for example, due to an insulated flange or a connection not across a full surface, the motor must be grounded via a grounding cable with a minimum 10 mm ² (AWG 6) cross-section or a grounding strip with a length as short as possible.	Reduce emissions, increase interference resistance.
Use twisted pair for 24 Vdc signals.	Reduce interference action on signal cables, reduce emissions.

Voltage Supply

EMC measures	Objective
Operate product on mains with a grounded neutral.	Enable the effect of the integrated mains filter.
Protection circuit if there is a risk of overvoltage.	Reduce risk of damage due to overvoltages.

Motor and Encoder Cables

From an EMC perspective, motor supply cables and encoder cables are particularly important. Only use pre-configured cables, or cables with the prescribed properties, and comply with the following EMC measures.

EMC measures	Objective
Do not install switching elements in motor cables or encoder cables.	Reduces interference.
Route motor cable with a distance of at least 20 cm (7.84 in) to the signal cables or insert shield plates between the motor supply cable and the signal cable.	Reduces mutual interference.
For cabling that approaches the maximum cable distance specification, use potential equalization cables.	Reduce current on cable shield.
(1) If a cable must be cut through for installation purposes, the cables must be connected at the point of separation by using screen connections and metal housing.	

EMC measures	Objective
Route motor supply cables and encoder cables without any separation point ⁽¹⁾ .	Reduces emission.
(1) If a cable must be cut through for installation purposes, the cables must be connected at the point of separation by using screen connections and metal housing.	

Additional Measures for Improving the EMC

Depending on the respective application, the following measures may lead to an EMC compatible layout:

EMC measures	Objective
Upstream connection of mains line reactor (choke)	Reduction of the harmonic network oscillations, extension of the service life of the product.
Upstream connection of external mains filters	Improvement of the EMC limit values.
Special EMC-appropriate layout, for example, within an enclosed control cabinet complete with 15 dB attenuation of the interferences emitted	Improvement of the EMC limit values.

Deactivating the Y Capacitors

The grounding of the internal Y capacitors can be undone (disabled). Usually, it is not required to undo the grounding of the Y capacitors.

Screw location for deactivating/activating the internal Y capacitors:

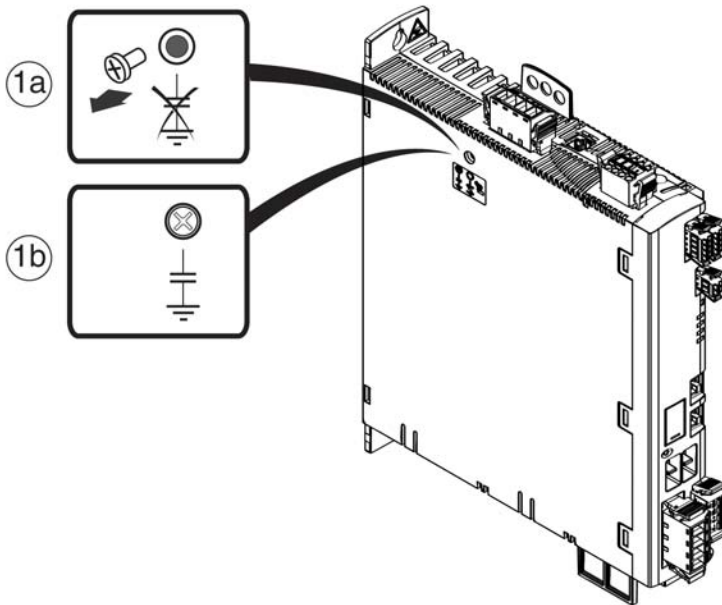

To deactivate the Y capacitors, remove the screw, see figure above. Keep this screw so you can reactivate the Y capacitors, if necessary.

NOTE: If the Y capacitors are disabled, the specified EMC characteristics no longer apply.

Section 3.2

Control Cabinet Planning

What Is in This Section?

This section contains the following topics:

Topic	Page
Degree of Protection (IP)	40
Mechanical and Climatic Environmental Conditions in the Control Cabinet	41
Using Cooling Units	42

Degree of Protection (IP)

Overview

Install components such that a degree of protection corresponding to the actual operational environment is set up.

For more information on the degree of protection of the component, refer to Ambient Conditions (*see page 124*).

The following ambient conditions may damage the components:

- Oil
- Moisture
- Electromagnetic interference
- Ambient temperature
- Metal dust deposits

WARNING

UNINTENDED EQUIPMENT OPERATION

- Observe and conform to ambient temperatures, storage temperatures and transport temperatures as specified in the operating manuals of the components.
- Prevent the formation of moisture during the operation, storage and transport of individual components.
- Conform to the vibration and shock requirements specified in the operating manuals for the components when operating, storing and transporting system components.

Failure to follow these instructions can result in death, serious injury, or equipment damage.

Mechanical and Climatic Environmental Conditions in the Control Cabinet

Overview

Step	Action
1	Observe the climatic and mechanical ambient conditions. For more information on the general climatic and mechanical environmental conditions according to IEC/EN 60721, refer to Ambient Conditions (<i>see page 124</i>).
2	Verify the technical data of the device whether the permitted deviations (for example, higher shock load or higher temperature) are specified.

Using Cooling Units

Installing a Cooling Unit

How to proceed when installing a cooling unit:

Step	Action
1	Position the cooling units so that no condensate drips out of the cooling unit onto electronic components or is sprayed by the cooling air flow.
2	Provide specially designed control cabinets for cooling units on the top of the control cabinet.
3	Design the control cabinet so that the cooling unit fan cannot spray any accumulated condensate onto the electronic components when it restarts after a pause.
4	When using cooling units, use only well-sealed control cabinets so that warm, humid outside air, which causes condensation, does not enter the cabinet.
5	When operating control cabinets with open doors during commissioning or maintenance, ensure that the electronic components are at no time cooler than the air in the control cabinet after the doors are shut, in order to avoid any condensation.
6	Continue to operate the cooling unit even when the system is switched off, so that the temperature of the air in the control cabinet and the air in the electronic components remains the same.
7	Set cooling unit to a fixed temperature of 40 °C (104 °F).
8	For cooling units with temperature monitoring, set the temperature limit to 40 °C (104 °F) so that the internal temperature of the control cabinet does not fall below the external air temperature.

WARNING

UNINTENDED EQUIPMENT OPERATION

Follow the installation instructions such that the condensation from the cooling unit can not enter electronic components.

Failure to follow these instructions can result in death, serious injury, or equipment damage.

Installing a cooling unit

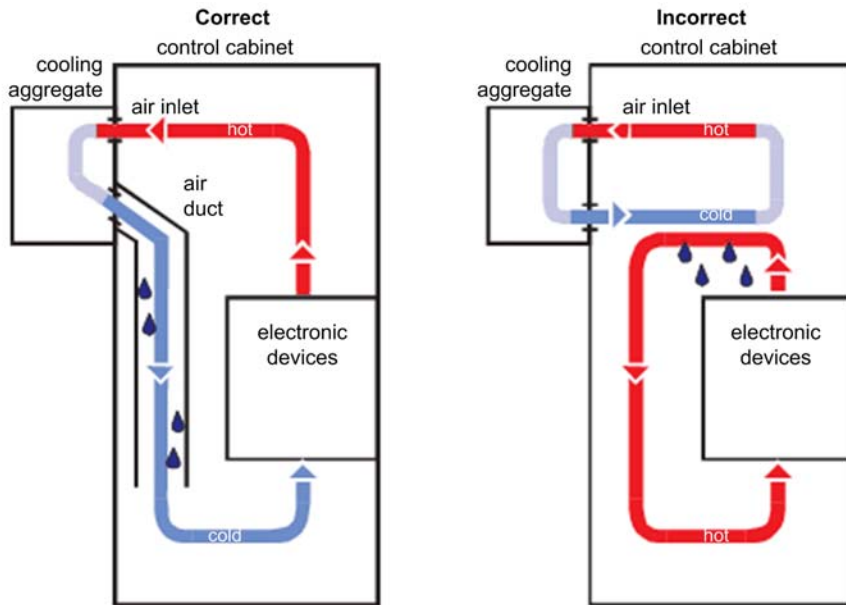

Section 3.3

Information about Wiring

What Is in This Section?

This section contains the following topics:

Topic	Page
General Information about Wiring	45
Cable Characteristics	46
Cable Assembly	47
ESD Protection Measures	47
Conditions for UL Compliant Use	48
Fusing the Mains Connection	49
Mains Contactor	50
Mains Filter	50
Mains Line Reactor (Choke)	51
Leakage (Touch) Current	52
Residual Current Operated Protective Device	53
Parallel Connection DC Bus	55
Shield Connection	60

General Information about Wiring

Overview

Use only Schneider Electric approved devices in your application, and especially Schneider Electric pre-fabricated cables wherever and whenever possible.

For further information, refer to Cable Characteristics (*see page 46*).

For information on the tightening torques and cable cross-sections, refer to Electrical Connections Overview (*see page 112*).

Observe the following points when wiring:

1. Observe the minimum cross-sections of the cables necessary for the load carrying capacity of the equipment being connected.
2. Verify the integrity of cable shields to ensure continuity to ground.
3. Ensure that there is a proper connection to ground for all interconnected equipment.
4. Ensure connection of the motors to the machine ground.
5. Eliminate any ground loops.
6. Do not disconnect cable connections terminals when under power.
7. Ensure that all ground connections have sufficient surface area continuity.
8. Do not interchange motor phases.
9. Do not interchange encoder connections.
10. Do not interchange the EMERGENCY STOP circuits.

Example

If, for example, two parallel conductors are shown as coming from one point, you may not run just one conductor and then branch it off at a later point. If it is wired this way, induction loops (interference emitters and antennas) as well as interfering potential shifts may occur.

DANGER

INCORRECT OR UNAVAILABLE GROUNDING

Remove paint across a large surface at the installation points before installing the devices (bare metal connection).

Failure to follow these instructions will result in death or serious injury.

Cable Characteristics

Characteristics

Cable	Property	Unit
Motor supply cables voltage isolation	Conducting wire: 1000 (UL and CSA) Signal wire brake: 600 (UL)	[Vac]
Current carrying capacity	According to DIN VDE 0298 Part 4	–
Encoder cable isolation voltage	300 (UL and CSA)	[Vac]
Temperature range	-40...+90 / -40...+194 (fixed routing) -20...+80 / -4...+176 (mobile)	[°C] / [°F]
Bending radius	5 x diameter (fixed routing) 12 x diameter (mobile)	–
Corrosion resistance of the cable insulation	Oil resistant PUR, hydrogen peroxide	–
Sheath	halogen-free	–
Shield	Braided shield	–
Covering of the braided shield	≥85	[%]

Motor and encoder cables are drag chain capable.

Cable characteristics of the Sercos cable (see the Schneider Electric catalog for the various cables available):

Property	Value
Voltage isolation (jacket)	300 Vdc
Temperature range	-20... +60 °C / -4...+140 °F
Cable diameter	5.8 ± 0.2 mm (0.23 ± 0.008 in.)
Bending radius	8 x diameter (fixed routing)
Sheath	PVC, flame-retardant
Cable type and shielding	CAT6 with S/FTP (Sercos III)

Cable Assembly

Overview

For configuring and coding the cables, you respectively need the enclosed accessory kit:

Overview of the connectors of the Lexium 52		
Accessory part	Number	Connection designation
Connector mains connection (power stage supply)	1	CN1
Connector for the connection 24 V control supply, safety function STO	1	CN2
Connector for the digital inputs and digital outputs	1	CN6
Connector Ready contact	1	CN7
Connector connection of the motor phases	1	CN10
Connector motor holding brake, motor temperature	1	CN11

ESD Protection Measures

General

Observe the following instructions to help avoid damages due to electrostatic discharge:

NOTICE

ELECTROSTATIC DISCHARGE

- Do not touch any of the electrical connections or components.
- Prevent electrostatic charges, for example, by wearing appropriate clothing.
- If you must touch circuit boards, do so only on the edges.
- Move the circuit boards as little as possible.
- Remove existing static charge by touching a grounded, metallic surface.

Failure to follow these instructions can result in equipment damage.

Conditions for UL Compliant Use

General

According to UL508C rules, direct measurement motor over temperature sensing is required. Therefore, connect the temperature sensor of the motor to connection **CN11**.

Fuses

Use class CC or class J fuses according to UL 248-4.

Maximum fuse for Lexium 52 to be connected upstream at 30 A.

Wiring

Use at least 60/75 °C (140/167 °F) copper conductors.

Three-Phase Devices

400/480 V three-phase devices may be operated at 480 Y / 277 Vac networks maximum.

Overvoltage Category

Use only in overvoltage category III or where the maximum available Rated Impulse Withstand Voltage Peak is equal or less than 4000 Volts.", or equivalent.

Short-Circuit Current Rating (SCCR)

Only connect the Lexium 52 Standalone Drive System to a mains supply network not exceeding the SCCR (Short Circuit Current Rating) from table below, or take appropriate measures according to UL 508A SB4 in the supply (feeder) circuit of the control cabinet to limit the short circuit current to a value below the least SCCR of those devices you are using from the following table:

Lexium 52 Standalone Drive System	Short-Circuit Current Rating ⁽¹⁾
Lexium 52	22 kA
(1) Using Class CC or J fuses.	

Integral solid state short circuit protection does not provide branch circuit protection. Branch circuit protection must be provided in accordance with the National Electrical Code and any additional local codes.

Line reactors according to UL 508 A (SB 4.2.1 Exception No. 1) are not required to have a short-circuit current rating (SCCR).

Fusing the Mains Connection

General

Maximum fuse to be connected upstream:

Description	Unit	LXM52DU60C	LXM52DD12C	LXM52DD18C	LXM52DD30C	LXM52DD72C
Maximum fuse to be connected upstream ⁽¹⁾	A	30/32	30/32	30/32	30/32	30/32
<p>(1) Fuses: safety fuse of class CC or J acc. to UL 248-4, alternatively overcurrent release with B or C characteristic. Instruction 30/32 A: For UL a maximum of 30 A is permitted. Smaller values may be used. The fuse has to be chosen so that it does not trigger at the specified current consumption.</p>						

Limit the external 24 Vdc supply of the Lexium 52 with adequate means to 50 A.

NOTE: The opening of the branch-circuit protective device (fuses in the case of UL conformance, or any circuit breaker) may be an indication that an abnormal condition has been interrupted. To reduce the risk of fire or electric shock, current-carrying parts and other components of the motor controller should be examined and replaced if damaged. If burnout of the current element of an overload relay occurs, the complete overload relay must be replaced.

 **DANGER**

FIRE, ELECTRIC SHOCK OR ARC FLASH

Examine and replace if necessary any current-carrying parts or other motor control components in the case of mains- or branch-circuit protection activation.

Failure to follow these instructions will result in death or serious injury.

Mains Contactor

General

The Lexium 52 requires a mains contactor in order to be able to remove power to the Lexium 52 components. This mains contactor is controlled by the Ready relay output. Here, the mains contactor may operate only if the Ready relay output contact is closed. The Ready chain may comprise additional switches which prevent the mains contactor from responding or cause the contactor to release although the Ready contact is closed, such as may be the case in your functional safety architecture.

The selection of the mains contactor must be in accordance with the protection requirements of the mains line.

For further information, refer to Fusing the Mains Connection (*see page 49*).

Mains Filter

Limit Values

This product meets the EMC requirements in accordance with the standard IEC 61800-3, provided that the EMC measures described in this manual are complied with during the installation.

If the selected combination of drive and motor does not meet category C1, the following must be observed:

 WARNING
HIGH-FREQUENCY INTERFERENCE
Install interference suppression measures in the case of high-frequency interference caused by this product if the installation does not meet C1 requirements or in residential environments.
Failure to follow these instructions can result in death, serious injury, or equipment damage.

Emitted Interference

The following limit values for emitted interferences are met for EMC-conform design and when using the cables available as accessories.

Length of the Motor Cables	IEC 61800 Class	Notes
< 20 m (65 ft) motor cable length	C3	-
> 20 m (65 ft) motor cable length	C3	external EMC filter required

NOTE: You can install additional external integrated mains filters if the internal attenuation of interferences is not sufficient. For questions on this, please contact your Schneider Electric representative.

Mains Line Reactor (Choke)

Overview

A mains line reactor (choke) is required for application architectures with more than 16 A mains current. Up to 16 A, a mains line reactor is necessary to reduce the harmonics of the mains current.

The rated power of the drives is limited. Without mains line reactors, the rated power of the drive is further reduced (refer also to the Technical Data (*see page 126*)). As a result the rated output current may not be reached at high output frequencies, i.e., at high motor speeds.

With UL/CSA Certification

Mains line reactor with UL / CSA certification:

- Schneider Electric: VPM05D100000 for architectures up to 10 A
- Schneider Electric: VPM05D250000 for architectures up to 25 A
- Schneider Electric: VPM05D500000 for architectures up to 50 A
- Schneider Electric: VW3 A4 551 for architectures up to 4 A
- Schneider Electric: VW3 A4 552 for architectures up to 10 A
- Schneider Electric: VW3 A4 553 for architectures up to 16 A
- Schneider Electric: VW3 A4 554 for architectures up to 30 A
- Schneider Electric: VW3 A4 555 for architectures up to 60 A

A shielded version of the connection cables is not required.

NOTE: Verify that the rated current of the mains line reactor is above preset overload protection of the protective device.

Leakage (Touch) Current

Overview

The following table contains leakage (touch) current per device:

Application	per Lexium 52
Typical (400 V, 50 Hz)	< 30 mA

NOTE: If the leakage (touch) current is too high for the respective application, use an isolating transformer on the mains supply.

This product has a leakage (touch) current greater than 3.5 mA. If the protective ground connection is interrupted, a hazardous leakage (touch) current may flow if the housing is touched.

DANGER

INSUFFICIENT GROUNDING

- Use a protective ground conductor with at least 10 mm² (AWG 6) or two protective ground conductors with the same or larger cross section of the conductors supplying the power terminals.
- Verify compliance with all local and national electrical code requirements as well as all other applicable regulations with respect to grounding of all equipment.

Failure to follow these instructions will result in death or serious injury.

Residual Current Operated Protective Device

General

This product has a leakage (touch) current greater than 3.5 mA. If the protective ground connection is interrupted, a hazardous leakage (touch) current may flow if the housing is touched.

DANGER

INSUFFICIENT GROUNDING

- Use a protective ground conductor with at least 10 mm² (AWG 6) or two protective ground conductors with the same or larger cross section of the conductors supplying the power terminals.
- Verify compliance with all local and national electrical code requirements as well as all other applicable regulations with respect to grounding of all equipment.

Failure to follow these instructions will result in death or serious injury.

Using Residual Current Protective Devices

Observe the following when using residual current protective devices:

NOTE: If an additional protection measure against indirect or direct (by rated residual current < 30 mA) contact comes into operation, then an upstream residual current circuit-breaker with 30 mA response threshold can be also triggered in normal operation through the device leakage (touch) current of the Lexium 52. Insulation damage or direct contact can cause a circuit connection with a direct current component in the ground conductor. By that the sensitivity of residual current circuit-breakers of the type A or AC is reduced and with that also the ability to protect other accessories in the system.

Therefore, only use the Lexium 52 with a universal current sensitive residual current circuit-breaker of the type B with a triggering threshold over 30 mA (for example, 300 mA, as a protection measure against a fire outbreak caused by insulation degradation).

NOTE: If on the line side of this electronic equipment a residual current protective device is used to protect against direct or indirect contact, then only type B is permitted. Otherwise another protection measure has to be used, like separating the electronic equipment from the environment through double or reinforced insulation or from the line by a transformer. Handle the residual current protective circuit-breakers of the type B for the design and mounting of electronic system carefully. All the residual current circuit breakers that are upstream to a residual current circuit breaker of the type B up to the supply transformer have to be of the type B.

NOTE: According to IEC 61800-5-1 Adjustable speed electrical power drive systems, Part 5-1: Safety requirements - Electrical, thermal and energy - residual current protective devices are required on components with an operational current greater than 3.5 mA for ac or 10 mA for dc.

Additionally, one of the following procedures is required:

1. Use a ground conductor cross section with at least 10 mm² (AWG 6) copper.
2. Monitor the ground conductor with an equipment that automatically shuts off in case of a detected error.
3. Install the second conductor electric parallel to the protective conductor by using separate terminals. This conductor must meet the requirements of DIN VDE 0100 part 540.

The protective housing provides protection from indirectly touching live parts.

Parallel Connection DC Bus

General

In the case of improper use of the parallel connection of the DC bus, the drive systems can be damaged after a period of time or even immediately.

⚠ WARNING
INOPERABLE SYSTEM PARTS AND LOSS OF PROCESS CONTROL
<ul style="list-style-type: none"> • Observe the requirements for using the parallel connection of the DC bus. • Do not connect in parallel the Lexium 52 to the Lexium 62. • Do not connect in parallel the Lexium 52 to the ATV32.
Failure to follow these instructions can result in death, serious injury, or equipment damage.

Operating Principle

Thanks to the parallel connection of the DC bus of several devices, the energy efficiency can be improved for some applications. Excess energy that is fed back and is generated during deceleration of the motor is converted into thermal energy without a connection to the DC bus. Energy exchange can be performed by means of a connection of the DC bus to several servo amplifiers. The energy fed back can be used to drive additional motors. In anti-cyclical operation during which a motor is decelerated and another motor simultaneously requires energy, fed back energy can be used effectively.

Firmware Version

A common DC bus requires the devices to have at least the specified firmware version:

Drive	Version
Lexium 52	V01.54.x.x

Cables for the DC Bus

A cable for the common DC bus must meet the following minimum requirements.

Shield	Shielded at cable lengths of > 20 cm (7.87 in)
Twisted pair	Twisted pair at cable lengths of > 20 cm (7.87 in)
Cable	Two wires, shielded
Maximum cable length between two drives	3 m (9.84 ft.)
Special characteristics	<ul style="list-style-type: none"> • Insulation must be rated for the DC bus voltage • Conductor cross section according to the calculated current, but at least 2* 6 mm² (2* AWG 10)

The connection of the fuses for the DC bus must be rated for the total maximum continuous current on the DC bus of all drives connected via the DC bus. Analyze the potentially most critical case in your application (for example EMERGENCY STOP) and select an appropriate conductor cross section.

DC Bus Connection

The DC bus is connected by using a plug and socket connection.

For information on the cable specifications, refer to Cables for the DC Bus (*see page 55*). Connector kits and pre-assembled cables are available from Schneider Electric.

Single Mains Fuse

A single fuse is sufficient if the total input current of all drives connected via the common DC bus is less than the maximum fuse rating shown in the following table:

Single mains fuse	Maximum fuse rating
Lexium 52	32 A

NOTE: A common mains switch must be used to switch on the power stage supplies simultaneously.

The graphic shows a single mains fuse for three-phase drives:

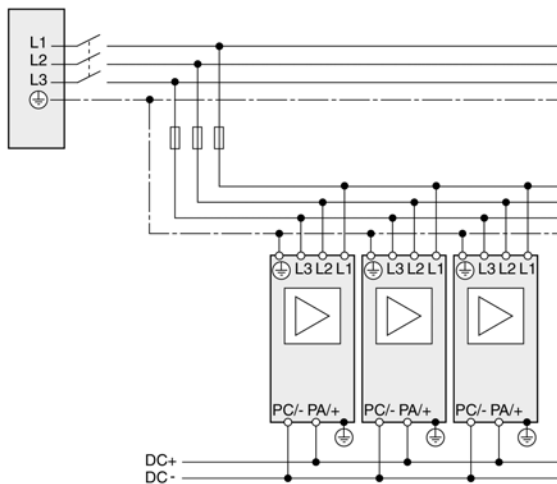

Mains Line Reactor (Choke)

A mains line reactor (choke) (*see page 51*) is required if at least one of the following criteria is met:

- The output power of the drive is to be increased.
- The short-circuit current rating (SCCR) of the supplying mains is greater than specified for the drives.
- Current harmonics are to be reduced.

If one drive requires a mains line reactor, then all drives connected via the DC bus must be equipped with mains line reactors.

The mains line reactor for several drives with a common AC fuse must be rated in such a way that the nominal current of the mains line reactor is greater than the total of the input current of the drives.

The fuse rating of the fuse upstream of the mains line reactor must not be greater than the nominal current of the mains line reactor.

The following graphic shows the wiring of drives with common AC fuse and a mains line reactor (example shows three-phase drives):

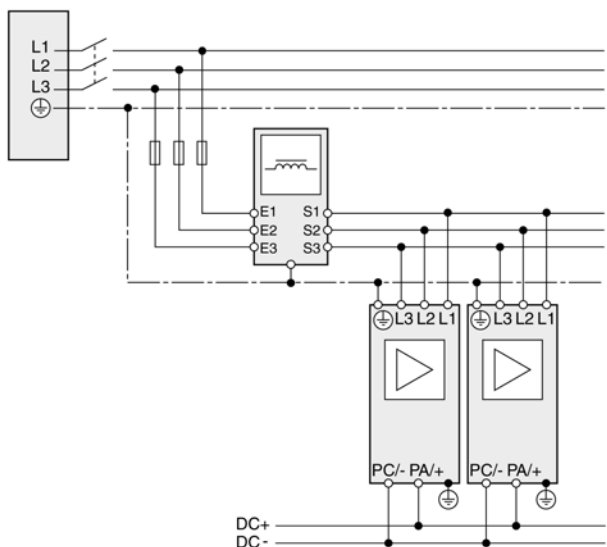

Mains Filter

The emission depends on the length of the motor cables. If the required limit value is not reached with the internal mains filter, you must use an external mains filter.

Observe the limit values (*see page 50*) for the mains filter.

The mains filter for several drives with a common AC fuse must be rated in such a way that the nominal current of the external mains filter is greater than the total of the input current of the drives.

The fuse rating of the fuse upstream of the external mains filter must not be greater than the nominal current of the external mains filter.

Mount the external mains filter in such a way that the lines from the mains filter to the drives are as short as possible. For EMC (Electromagnetic Compatibility (*see page 34*)) reasons, route the cables from the mains filter to the drives separately from the line to the mains filter.

External three-phase mains filters do not have a neutral conductor connection; they are only approved for three-phase devices.

The following graphic shows the wiring of an external mains filter (example shows three-phase drives):

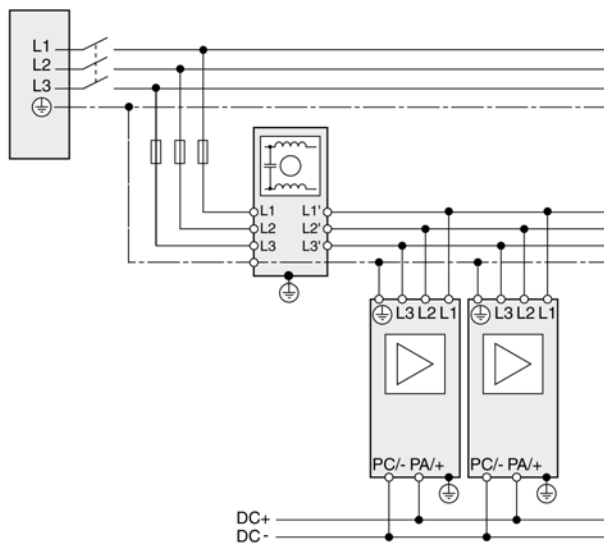

Mains Line Reactor and External Mains Filter

If a mains line reactor and an external mains line reactor are required, the mains line reactor and external mains filter must be arranged according to the following illustrations for EMC reasons.

The following graphic shows the wiring of drives with common mains fuse, mains line reactor, and mains filter (example shows three-phase drives):

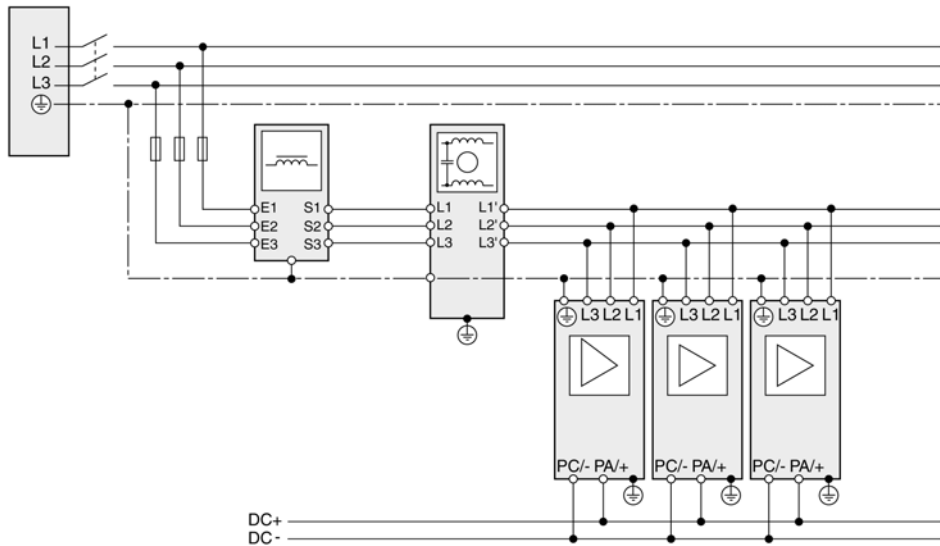

Installation

NOTICE

DESTRUCTION DUE TO INCORRECT OPERATION

Verify that the power stage supplies of the drives connected via a common DC bus are switched on simultaneously.

Failure to follow these instructions can result in equipment damage.

The following graphics show the specifications for drives with mains supply:

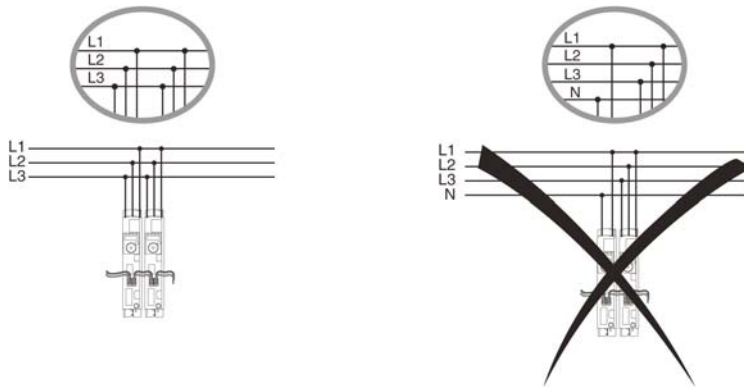

Shield Connection

General

Proceed as follows to connect the shield of the motor cable:

- Fix the cable shield across a large surface in the shield terminal at the bottom of the device.

NOTE: Alternatively, the shield connection can be done via shield terminal and bar.

Section 3.4

Functional Safety

What Is in This Section?

This section contains the following topics:

Topic	Page
Process Minimizing Risks Associated with the Machine	62
Inverter Enable Function	64
Setup, Installation and Maintenance	69
Application Proposals	70
Commissioning	73
Best Practices	74
Maintenance	76
Physical Environment	77
Safety Standards	78

Process Minimizing Risks Associated with the Machine

General

The goal of designing machines safely is to protect people. The risk associated with machines with electrically controlled drives comes chiefly from moving machine parts and electricity itself.

Only you, the user, machine builder, or system integrator can be aware of all the conditions and factors realized in the design of your application for the machine. Therefore, only you can determine the automation equipment and the related safeties and interlocks which can be properly used, and validate such usage.

Hazard and Risk Analysis

Based on the system configuration and utilization, a hazard and risk analysis must be carried out for the system (for example, according to EN ISO 12100 or EN ISO 13849-1). The results of this analysis must be considered when designing the machine, and subsequently applying safety-related equipment and safety-related functions. The results of your analysis may deviate from any application examples contained in the present or related documentation. For example, additional safety components may be required. In principle, the results from the hazard and risk analysis have priority.

WARNING

NON-CONFORMANCE TO SAFETY FUNCTION REQUIREMENTS

- Specify the requirements and/or measures to be implemented in the risk analysis you perform.
- Verify that your safety-related application complies to applicable safety regulations and standards.
- Make certain that appropriate procedures and measures (according to applicable sector standards) have been established to help avoid hazardous situations when operating the machine.
- Use appropriate safety interlocks where personnel and/or equipment hazards exist.
- Validate the overall safety-related function and thoroughly test the application.

Failure to follow these instructions can result in death, serious injury, or equipment damage.

The EN ISO 13849-1 Safety of machinery - Safety-related parts of control systems - Part 1: General principles for design describes an iterative process for the selection and design of safety-related parts of controllers to reduce the risk to the machine to a reasonable degree:

To perform risk assessment and risk minimization according to EN ISO 12100, proceed as follows:

1. Defining the boundary of the machine.
2. Identifying risks associated with the machine.
3. Assessing risks.
4. Evaluating risks.
5. Minimizing risks by:

- Intrinsically safe design
- Protective devices
- User information (see EN ISO 12100)

6. Designing safety-related controller parts (SRP/CS, Safety-Related Parts of the Control System) in an interactive process.

To design the safety-related controller parts in an interactive process, proceed as follows:

Step	Action
1	Identify necessary safety functions that are executed via SRP/CS (Safety-Related Parts of the Control System).
2	Determine required properties for each safety function.
3	Determine the required performance level PL_r .
4	Identify safety-related parts executing the safety function.
5	Determine the performance level PL of the afore-mentioned safety-related parts.
6	Verify the performance level PL for the safety function ($PL \geq PL_r$).
7	Verify if all requirements have been met (validation).

Additional information is available on www.schneider-electric.com.

Inverter Enable Function

Functional Description

With the Inverter Enable function (IE), you can bring drives to a defined safe stop.

In the sense of the relevant standards, the requirements of the stop category 0 (Safe Torque Off, STO) and stop category 1 (Safe Stop 1, SS1) can be met. Both categories lead to a torque-free motor while SS1 takes this state after a predefined time. As a result of the hazard and risk analysis, it may be necessary to choose an additional brake as a safety-related option (for example, for hanging loads).

Scope of Operation (Designated Safety Function)

The following circuit is a suggestion for the Lexium 52 system. In the circuit suggestions given, the "Safe Torque OFF, STO" safety-related function is carried out by switching off the trigger signals of the power stage. They transmit the PWM signals to the power stage (pulse pattern lock) using the "InverterEnable" signal.

Operating Principle

The safety function Inverter Enable is triggered via 2 redundant inputs. In order to maintain the dual-channel design, both inputs must be switched individually. The switching operation must take place for both inputs simultaneously (time offset < 1 s). The power stage is being disabled. The motor can no longer generate a torque. If only one of both inputs is disabled or the time offset is too long, the power stage is disabled and a detected error message is issued.

- After the emergency stop device is activated, a controlled ramp down takes place for the drive.
- In the process, the DC bus voltage increases until the braking resistor is switched on.
- In the braking resistor, the energy which is fed back from the motor is converted to heat.
- The power circuit breaker and/or the Inverter Enable signal must remain energized until the drive stops.
- At the latest after the normal braking time, the Inverter Enable signal is switched off by the delayed contacts of the safety POU PREVENTA XPS-AV.
- After this, the drive is in a defined safe stop.

Example stop category 1 with external EMERGENCY STOP safety POU Preventa XPS-AV

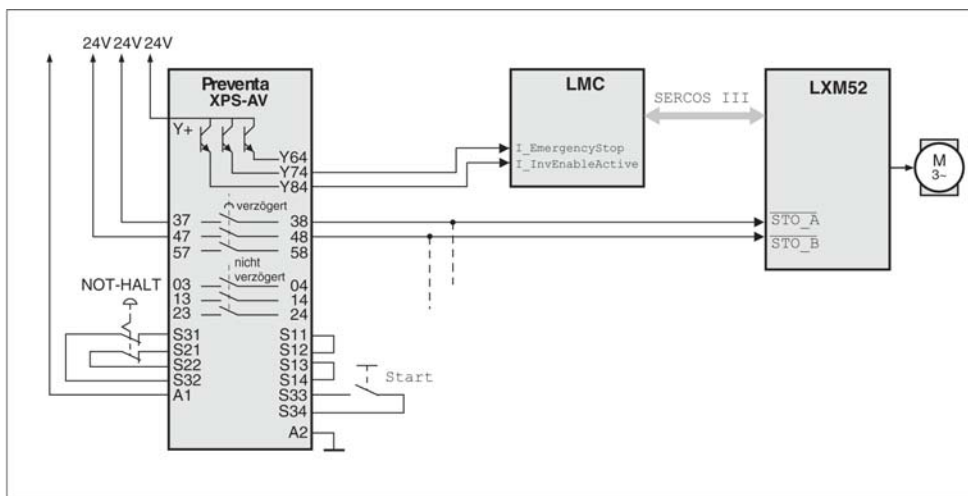

Defined Safe State

Inverter Enable is synonymous with "Safe Torque Off (STO)" according to IEC 61800-5-2:2007. This torque-free state is automatically entered when errors are detected and is therefore the defined safe state of the drive.

Mode of Operation

The safety-related circuit with InverterEnable was developed to minimize wear on the mains contactor. When the stop or the emergency stop button is activated, the mains contactor is not switched off. The defined safe stop is achieved by removing the "InverterEnable" for the optocouple in the power stage. Thus, the PWM signals cannot control the power stage so that a startup of the drives is prevented (pulse pattern lock).

You can use the Inverter Enable function to implement the control function "Stopping in case of emergency" (EN 60204-1) for stop categories 0 and 1. Use an appropriate external safety-related circuit to prevent the unintended restart of the drive after a stop, as required in the machine directive.

Stop Category 0

In stop category 0 (Safe Torque Off, STO), the drive coasts to a stop (provided there are no external forces operating to the contrary). The STO safety-related function is intended to help prevent an unintended start-up, not stop a motor, and therefore corresponds to an unassisted stop in accordance with IEC 60204-1.

In circumstances where external influences are present, the coast down time depends on physical properties of the components used (such as weight, torque, friction, etc.), and additional measures such as mechanical brakes may be necessary to help prevent any hazard from materializing. That is to say, if this means a hazard to your personnel or equipment, you must take appropriate measures (refer to Hazard and Risk Analysis (*see page 62*)).

WARNING

UNINTENDED EQUIPMENT OPERATION

- Make certain that no hazards can arise for persons or material during the coast down period of the axis/machine.
- Do not enter the zone of operation during the coast down period.
- Ensure that no other persons can access the zone of operation during the coast down period.
- Use appropriate safety interlocks where personnel and/or equipment hazards exist.

Failure to follow these instructions can result in death, serious injury, or equipment damage.

Stop Category 1

For stops of category 1 (Safe Stop 1, SS1) you can request a controlled stop via the PacDrive LMC. The controlled stop by the PacDrive LMC is not safety-relevant, nor monitored, and does not perform as defined in the case of a power outage or if an error is detected. The final switch off in the defined safe state is accomplished by switching off the "Inverter Enable" input. This has to be implemented by means of an external safety-related switching device with safety-related delay (see application proposal (*see page 70*)).

Independent of the safety function, the detectable errors not affecting the safety function are recognized by the controller, thus avoiding the drive from starting by switching off the mains contactor. Contactor K2 prevents the mains contactor from being switched on.

Execute Muting

To execute muting, determine the muting reaction time for switching off, that is, without the Inverter Enable function, within the application. Should a response time be required because of the risk assessment of the machine, the total response time of the machine has to be taken into account. That is to say, the components related to the safety functions from the sensor to the drive shaft or the driven mechanics have to be considered. The determined reaction time must correspond to the results of the hazard and risk analysis.

WARNING

UNINTENDED EQUIPMENT OPERATION

- Verify that the maximum response time corresponds to your risk analysis.
- Be sure that your risk analysis includes an evaluation for the maximum response time.
- Validate the overall function with regard to the maximum response time and thoroughly test the application.

Failure to follow these instructions can result in death, serious injury, or equipment damage.

Proceed as follows to disable the Inverter Enable function:

Supply the /STO_A or /STO_B input with 24 Vdc to deactivate the Inverter Enable function.

The axes without Inverter Enable function become torque-free via the mains contactor and come to a stop. For more information, refer to Stop Category 0 (*see page 65*).

Validity of the Safety Case

The safety case for the Inverter Enable function of the Lexium 52 system is identified and defined by the standards listed in Safety standards (*see page 78*). The safety case of the Lexium 52 system Inverter Enable function applies to the following firmware (FW) versions and hardware codes, which can be found examining the appropriate software object in SoMachine Motion (*see SoMachine Motion, Programming Guide*):

Device	Hardware code	FW version	FPGA version
LXM 52DU60C	xxxxxxxxx1xxx	V01.35.07.00 V01.36.12.00 V01.36.16.00 V01.50.05.00 V01.51.12.00 V01.53.07.00	00/06/204A/00/04-02
LXM 52DD12C	xxxxxxxxx1xxx	V01.35.07.00 V01.36.12.00 V01.36.16.00 V01.50.05.00 V01.51.12.00 V01.53.07.00	00/06/204A/00/04-02
LXM 52DD18C	xxxxxxxxx1xxx	V01.35.07.00 V01.36.12.00 V01.36.16.00 V01.50.05.00 V01.51.12.00 V01.53.07.00	00/06/204A/00/04-02

Device	Hardware code	FW version	FPGA version
LXM 52DD30C	xxxxxxxxx1xxx	V01.35.07.00 V01.36.12.00 V01.36.16.00 V01.50.05.00 V01.51.12.00 V01.53.07.00	00/06/204A/00/04-02
LXM 52DD72C	xxxxxxxxx1xxx	V01.35.07.00 V01.36.12.00 V01.36.16.00 V01.50.05.00 V01.51.12.00 V01.53.07.00	00/06/204A/00/04-02

For questions on this, contact your Schneider Electric representative.

Interface and Control

The Inverter Enable function is operated via the switching thresholds of the Inverter Enable inputs /STO_A and /STO_B.

- STO active: $-3\text{ V} \leq U_{IE} \leq 5\text{ V}$
- Power stage active: $15\text{ V} \leq U_{IE} \leq 30\text{ V}$

For information on the technical data and electrical connections, refer to the chapter Technical Data (*see page 123*).

Setup, Installation and Maintenance

Prevent Possible Unintended Operation and Avoid Overvoltage

The following measures avoid overvoltages and help prevent possible unintended equipment operation through conductive pollution or parts falling into the device:

DANGER

ELECTRIC SHOCK, EXPLOSION, OR ARC FLASH

- Install Lexium 52 in a control cabinet or housing with a minimum IP 54 rating.
- Comply with the clearances and creepage distances according to EN 50178.
- Lexium 52 must only be operated with 24 Vdc power supplies certified according to EN 60950 or EN 50178.

Failure to follow these instructions will result in death or serious injury.

NOTE: These power supply units do not deliver an overvoltage over 120 Vdc for more than 120 ms or no permanent overvoltage over 60 Vdc.

Only operate the drive system with approved, specified cables, accessories and replacement equipment by Schneider Electric.

DANGER

ELECTRIC SHOCK OR ARC FLASH

Do not use non-Schneider Electric approved cables, accessories or any type of replacement equipment.

Failure to follow these instructions will result in death or serious injury.

Avoid Unintentional Restart

The unintentional restart of the equipment must be avoided by appropriate means, depending on your particular application.

DANGER

UNINTENTIONAL RESTART OF THE MOTOR

- Ensure that a restart of the motor is not possible after a return of power or the tripping of a functional safety device unless preceded by a deliberate enable signal from the system.
- Ensure that the enable signal meets the specified safety criteria.

Failure to follow these instructions will result in death or serious injury.

Application Proposals

Safe Stop Category 1 (SS1)

There is one application proposal to implement the safe stop of category 1 (SS1):

- LXM52-SS1-001: Inverter Enable circuit for PacDrive 3 Safe Stop 1 (SS1) with a protection circuit and 2-channel switch-off

Notes on Application Proposals - General

- All application proposals provide for a protected /STO_A or /STO_B wiring (control cabinet IP54) from the safety switch device to the Lexium 52, as faults need to be ruled out.
- Protection against automatic restart is ensured by the external safety switch device.
- If potential errors cannot be ruled out, a diagnostic can optionally be provided for the 2-channel variant. This must be realized internally and is not shown in the application proposal.

Notes on Application Proposals - Notes to LXM52-SS1-001

The mains contactor K1 in this circuit proposal is not necessary for functional safety purposes. It is, however, used in the application proposal for the device protection.

Application proposal for the load cycle (drawing number LXM52-SS1-001)

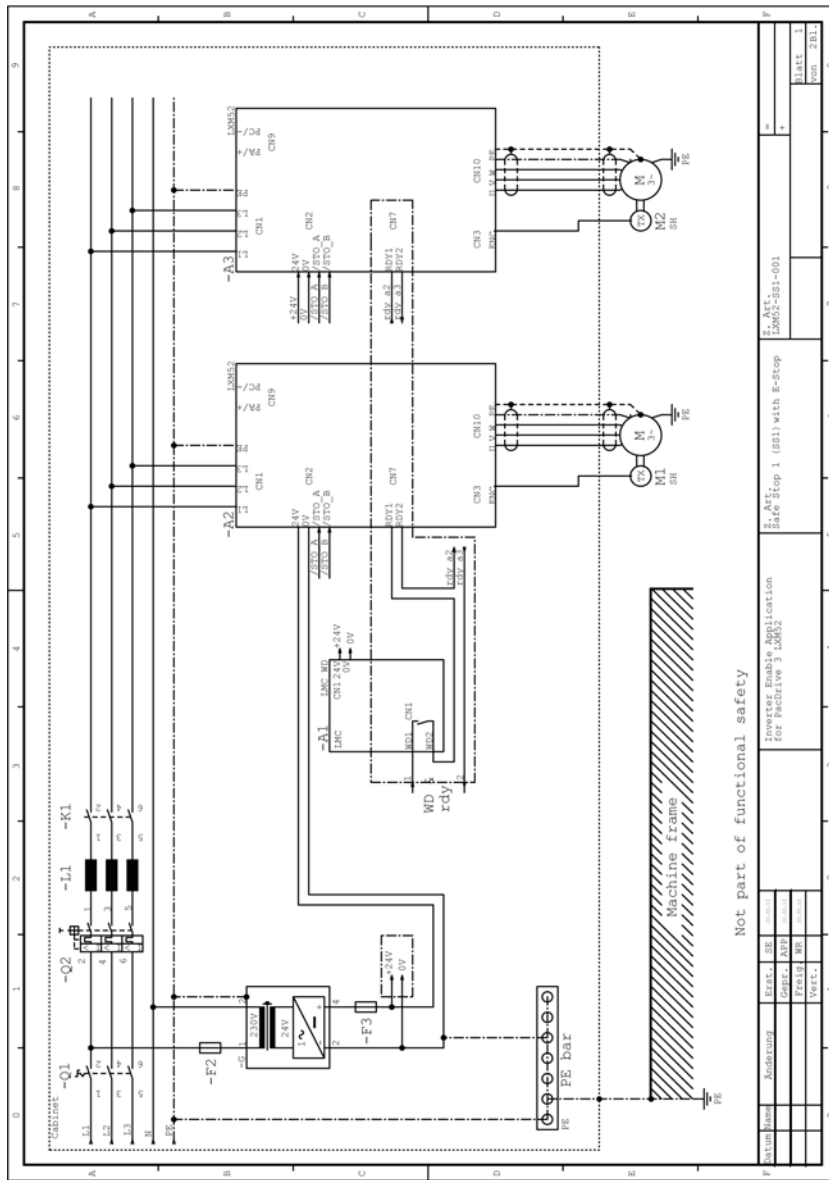

Not part of functional safety

Inverter Enable Application for FeDrive 3 LXM52

Err. Mkt.: Safe Stop 1 (SS1) with E-Stop

Err. Mkt.: LXM52-SS1-001

Item	Code	Ext. SE	Ext. APF	Ext. MS	Ext. V

Commissioning

General

Step	Action
1	Carry out a functional test of the STO function for all drives that need the safety function.
2	Especially verify the correct application of the axes without Inverter Enable function.
3	Complete installation in accordance with the EMC regulations and further specifications in the device operating manuals.
4	Afterwards, commission the drive systems.

Best Practices

General

At machine start-up, the connected drives are usually hidden from sight of the machine operator and cannot be monitored directly.

 WARNING
UNSUPERVISED MACHINE START-UP
Only start the machine if there are no persons within the zone of operation of moving machine components.
Failure to follow these instructions can result in death, serious injury, or equipment damage.

Verify Connections

Step	Action
1	Verify all terminals, connectors, and other connections on all system components for correct and firm fit.
2	Only use robust connectors and secure fixings.
3	Verify the protective ground (earth) 24 Vdc PELV (Protective Extra Low Voltage) supply.
4	Verify the wiring of the safety function to the axes to avoid an interchange of the /STO_A and /STO_B inputs as well as the 24 V supply.
5	Use coded connectors (refer to chapter Information about Wiring (<i>see page 44</i>)) and perform a commissioning test (refer to chapter Commissioning (<i>see page 73</i>)).
6	Use only appropriate transport packaging to forward or return individual devices.

 DANGER
ELECTRIC SHOCK BY INADEQUATE PROTECTIVE SEPARATION
Only connect devices, electrical components, or lines to the signal voltage connectors of these products that feature a sufficient, protective separation from the connected circuits in accordance with the standards (IEC 61800-5-1: Adjustable speed electrical power drive systems - safety requirements).
Failure to follow these instructions will result in death or serious injury.

External Forces

The defined safe state of the motor is the torque-free output shaft. If external forces act upon the output shaft, it will not necessarily maintain its position. In any case, the motor will coast to an unassisted stop. This coast down time depends on physical properties of the components used (such as weight, torque, friction, etc.), and additional measures such as mechanical brakes may be necessary to help prevent any hazard from materializing. If the torque-free defined safe state is inappropriate for your application where external forces may move the output shaft as determined by your risk assessment, implement other external safety-related measures.

WARNING

UNINTENDED EQUIPMENT OPERATION

- Make certain that no hazards can arise for persons or material during the coast down period of the axis/machine.
- Do not enter the zone of operation during the coast down period.
- Ensure that no other persons can access the zone of operation during the coast down period.
- Use appropriate safety interlocks where personnel and/or equipment hazards exist.

Failure to follow these instructions can result in death, serious injury, or equipment damage.

Hanging and Pulling Loads

WARNING

UNINTENDED AXIS MOVEMENT

- Do not use the internal holding brake as a safety-related measure.
- Only use certified external brakes as safety-related measures.

Failure to follow these instructions can result in death, serious injury, or equipment damage.

If the suspension of hanging / pulling loads is a safety objective for the machine, then you can only achieve this objective by using an appropriate external brake as a safety-related measure.

NOTE: The drive does not provide its own safety-related output to connect an external brake to use as a safety-related measure.

Maintenance

General

The Inverter Enable function has been designed for a defined lifetime that does not require to verify the safety-related function, nor any specific maintenance requirements. After this lifetime (*see page 78*) has elapsed, a statement about the Inverter Enable function cannot be made due to the aging of the component. If you want to ensure the functional safety after this period, you need to replace the device that includes the safety function.

NOTE: Subject the product to a complete function test after replacement.

For information about initial start-up and maintenance, refer to the chapter Installation and Maintenance (*see page 81*) of this operating instruction chapter.

Physical Environment

General

The system is not protected against physical or chemical sources of damage by any design features, such as:

- toxic,
- explosive,
- corrosive,
- highly reactive, or
- inflammable types.

This equipment has been designed to operate outside of any hazardous location. Only install this equipment in zones known to be free of a hazardous atmosphere.

DANGER

POTENTIAL FOR EXPLOSION

Install and use this equipment in non-hazardous locations only.

Failure to follow these instructions will result in death or serious injury.

WARNING

UNINTENDED EQUIPMENT OPERATION

- Observe and conform to ambient temperatures, storage temperatures and transport temperatures as specified in the operating manuals of the components.
- Prevent the formation of moisture during the operation, storage and transport of individual components.
- Conform to the vibration and shock requirements specified in the operating manuals for the components when operating, storing and transporting system components.

Failure to follow these instructions can result in death, serious injury, or equipment damage.

The Lexium 52 Drive System must only be installed in an electrical equipment enclosure (for example, in a control cabinet).

The electrical equipment enclosure must be lockable by using a key or tool.

Safety Standards

General

The designated safety functions have been designed and tested for functional safety according to the following standards:

- IEC 61508:2010
- IEC 61800-5-2:2007
- EN ISO 13849-1:2008
- IEC 62061:2005

An independent assessment was performed by TÜV NORD.

According to the above listed standards, the figures for the Lexium 52 for using the Inverter Enable are as follows:

Standard characteristics	Value
SFF (IEC 61508) Safe Failure Fraction	80%
HFT (IEC 61508) Hardware Fault Tolerance	1
Type (IEC 61508)	A
SIL (IEC 61508) Safety Integrity Level SILCL (IEC 62061) Safety Integrity Level claim limit	3
PFH (IEC 61508) Probability of Dangerous Failures per Hour	$1 \cdot 10^{-9}/h$
PL (cat) (EN ISO 13849-1) Performance Level (Category)	e (3)
MTTFd (EN ISO 13849-1) Mean Time to Dangerous Failure	1400 years
DC (EN ISO 13849-1) Diagnostic Coverage	90%
Lifetime	20 years
Maximum reaction time until switch off with the Inverter Enable function	10 ms
NOTE: The values specified are rounded individually and are therefore not a result of a conversion by for example, PFH in MTTFd or the comparative tables from EN ISO13849-1:2008.	

Section 3.5

Special Conditions

Low Air Pressure

General

If the installation altitude exceeds the specified rated installation altitude, the performance of the entire system is reduced.

Power reduction at increased installation altitude:

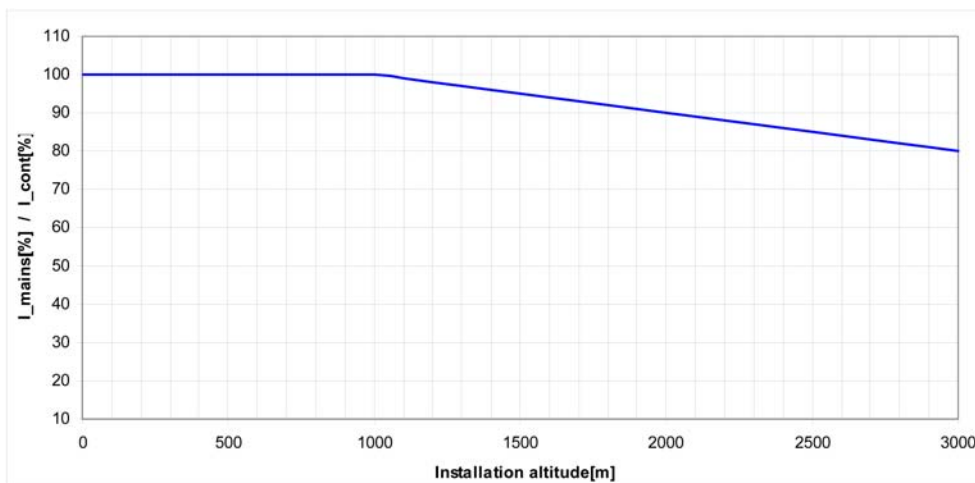

NOTE: Multiply the values with the nominal current at 40 °C (104 °F) in order to calculate the maximum continuous current value, depending on the required installation altitude.

NOTE: From a height of 1000 m, the maximum permissible ambient temperature is 45 °C (113 °F).

NOTE: From a height of 2000 m, the maximum permissible ambient temperature is 40 °C (104 °F) and the overvoltage category II must be observed.

Chapter 4

Installation and Maintenance

General Information

Proceed with care during the following steps in order to help to avoid the following points:

- Injuries and material damage
- Incorrect installation and programming of components
- incorrect operation of components
- use of non-authorized cables or modified components

What Is in This Chapter?

This chapter contains the following sections:

Section	Topic	Page
4.1	Commissioning	82
4.2	Maintenance, Repair, Cleaning, Replacement Equipment Inventory	93
4.3	Replacing Components and Cables	99

Section 4.1

Commissioning

What Is in This Section?

This section contains the following topics:

Topic	Page
Prerequisites for Commissioning	83
Preparing Commissioning	84
Preparing the Control Cabinet	86
Mechanical Mounting	91
Motor Cable and External Shield Connection	92

Prerequisites for Commissioning

Prerequisites

DANGER

ELECTRIC SHOCK, EXPLOSION, OR ARC FLASH

- Disconnect all power from all equipment including connected devices prior to removing any covers or doors, or installing or removing any accessories, hardware, cables, or wires.
- Place a "Do Not Turn On" or equivalent hazard label on all power switches and lock them in the non-energized position.
- Wait 15 minutes to allow the residual energy of the DC bus capacitors to discharge.
- Measure the voltage on the DC bus with a properly rated voltage sensing device and verify that the voltage is less than 42.4 Vdc.
- Do not assume that the DC bus is voltage-free when the DC bus LED is off.
- Block the motor shaft to prevent rotation prior to performing any type of work on the drive system.
- Do not create a short-circuit across the DC bus terminals or the DC bus capacitors.
- Replace and secure all covers, accessories, hardware, cables, and wires and confirm that a proper ground connection exists before applying power to the unit.
- Use only the specified voltage when operating this equipment and any associated products.

Failure to follow these instructions will result in death or serious injury.

DANGER

ELECTRIC SHOCK, EXPLOSION, OR ARC FLASH

- Operate electrical components only with a connected protective ground (earth) cable.
- After the installation, verify the secure connection of the protective ground (earth) cable to all electrical devices to ensure that connection complies with the connection diagram.
- Before enabling the device, safely cover the live components to prevent contact.
- Do not touch the electrical connection points of the components when the module is energized.
- Provide protection against indirect contact (EN 50178).
- Connect and disconnect cables and terminals only after you have verified that the power has been removed from the system.
- Insulate the unused conductors on both ends of the motor cable.

Failure to follow these instructions will result in death or serious injury.

Preparing Commissioning

Prerequisite

Verify safety-related circuits for proper function, if applicable.

ESD Protection

Observe the following instructions to help avoid damages due to electrostatic discharge:

<i>NOTICE</i>
<p>ELECTROSTATIC DISCHARGE</p> <ul style="list-style-type: none">● Do not touch any of the electrical connections or components.● Prevent electrostatic charges, for example, by wearing appropriate clothing.● If you must touch circuit boards, do so only on the edges.● Move the circuit boards as little as possible.● Remove existing static charge by touching a grounded, metallic surface. <p>Failure to follow these instructions can result in equipment damage.</p>

Unpacking

How to unpack the device:

Step	Action
1	Remove packaging
2	Dispose of the packaging material in accordance with the relevant local regulations.

Verifying

How to verify the device:

Step	Action
1	Verify that the delivery is complete on the basis of the delivery slip.
2	Closely inspect the device for any signs of damage.
3	Verify the data with the help of the nameplates.
4	Observe requirements for the installation location.
5	In addition to the following instructions, also note the information in the chapter Planning (<i>see page 33</i>).

WARNING

UNINTENDED EQUIPMENT OPERATION

- Do not mount or commission damaged drive systems.
- Do not modify the drive systems.
- Send back inoperative devices.

Failure to follow these instructions can result in death, serious injury, or equipment damage.

Preparing the Control Cabinet

Overview

⚠ DANGER

INCORRECT OR UNAVAILABLE GROUNDING

Remove paint across a large surface at the installation points before installing the devices (bare metal connection).

Failure to follow these instructions will result in death or serious injury.

Step	Action
1	If necessary to maintain and respect the maximum ambient operating temperature, install additional fan in the control cabinet.
2	Do not block the fan air inlet of the product.

Assembly Distances, Ventilation

Keep a distance of at least 100 mm (3.94 in) above and below the devices.

Assembly distances and air circulation.

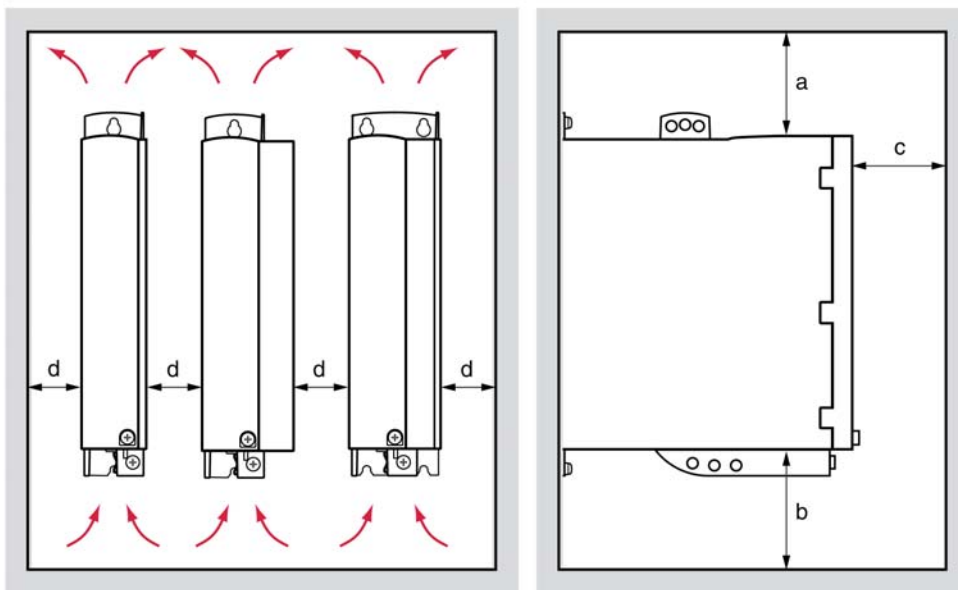

Distance	Air circulation
$a \geq 100 \text{ mm (3.94 in)}$	Clearance above the device.
$b \geq 100 \text{ mm (3.94 in)}$	Clearance below the device.
$c \geq 60 \text{ mm (2.36 in)}$	Clearance in front of the device.
$d \geq 0 \text{ mm (0 in)}^{(1)}$	Clearance between the devices

(1) Select the distance d so that the Sercos cables are not under tension (see following figure).

NOTICE

UNSUCCESSFUL OR INTERMITTENT SERCOS COMMUNICATIONS

- Select the space between two devices (distance d in the drawing above) so that the Sercos cables are not under tension.
- Use an identical value for the space above the device (distance a in the drawing above) for all drives that are mounted in the control cabinet in the same row.
- Only use cables and accessory parts from Schneider Electric.

Failure to follow these instructions can result in equipment damage.

Sercos cabling

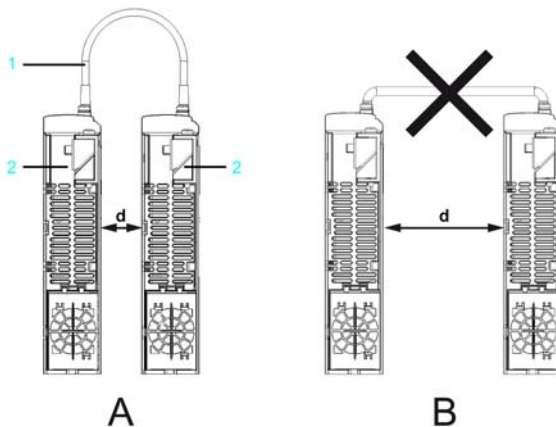

- 1 Sercos cable
- 2 Lexium 52
- A** Correct assembling: The distance **d** between the two Lexium 52 is selected such that the Sercos cables are not under tension.
- B** Incorrect assembling: Excessive distance **d** between the two Lexium 52, whereby the Sercos cable is under tension.

Dimensions for the Mounting Hole

Step	Action
1	Take the dimensions from the dimensional drawings in order to calculate the distances between several devices.
2	Observe tolerances as well as distances to the cable channels and adjacent control cabinet series.

Dimensional drawing 1

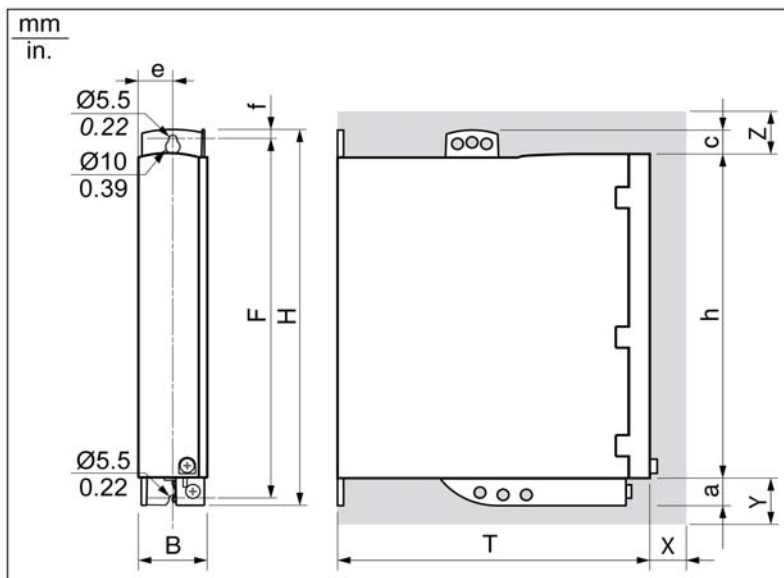

Dimensional drawing 2

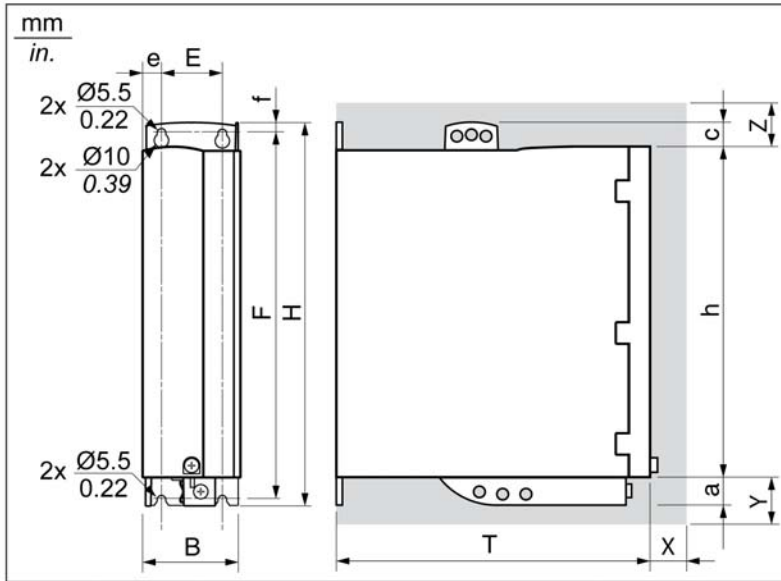

Dimensions

Parameter	Value			
Lexium 52...	U60	D12 D18	D30	D72
Figure	Dimensional drawing 1	Dimensional drawing 1	Dimensional drawing 2	Dimensional drawing 2
B	48 ±1 mm (1.89 ±0.04 in)		68 ±1 mm (1.89 ±0.04 in)	108 ±1 mm (1.89 ±0.04 in)
T	225 mm (8.86 in)			
H	270 mm (10.63 in)			274 mm (10.79 in)
e	24 mm (0.94 in)		13 mm (0.51 in)	
E	-		42 mm (1.65 in)	82 mm (3.23 in)
F	258 mm (10.16 in)			
f	7.5 mm (0.30 in)			
a	20 mm (0.79 in)			24 mm (0.95 in)
h	230 mm (9.06 in)			
c	20 mm (0.79 in)			
(1)	>1 m/s			

Parameter	Value			
X required clearance	60 mm (2.36 in)			
Y required clearance	100 mm (3.94 in)			
Z required clearance	100 mm (3.94 in)			
Cooling type	Convection ⁽¹⁾	Fan 40 mm (1.57 in)	Fan 60 mm (2.36 in)	Fan 80 mm (3.15 in)
(1) >1 m/s				

The connection cables of the device have to lead upward and downward.

In order to ensure sufficient air circulation and a cable routing without kinks, the following distances must be kept:

- At least 100 mm (3.94 in) of clearance are required above the device.
- At least 100 mm (3.94 in) of clearance are required below the device.
- At least 60 mm (2.36 in) of clearance are required in front of the device.

Mechanical Mounting

Procedure

For information concerning drilling centers, refer to Dimensions for the Mounting Hole (*see page 88*). For assembling and mounting, follow the steps in this table:

Step	Action
1	Screw pan-head screws M6 (socket head cap screws) into the prepared installation holes.
2	Keep a distance of 10 mm (0.39 in) between the screw head and the mounting surface.
3	Hook in device and verify the vertical mounting arrangement.
4	Tighten the mounting screws (torque: 4.6 Nm (41 lbf in)).

Motor Cable and External Shield Connection

Procedure

For the EMC requirements for the motor cables, refer to Electromagnetic Compatibility, EMC (*see page 34*). To connect the motor cable and the external shield connection, follow the steps in this table:

Step	Action
1	Connect the motor phases and protective ground conductor to CN10 (<i>see page 120</i>). Verify that the connections U, V, W and PE (protective ground/earth) match at the motor and the device. Note the tightening torque specified for the terminal screws (<i>see page 112</i>).
2	Connect the conductors for holding brake and temperature to CN11 (<i>see page 120</i>).
3	Verify that the connector locks snap in properly at the housing.
4	Connect the cable shield to the shield clamp (large surface area contact).

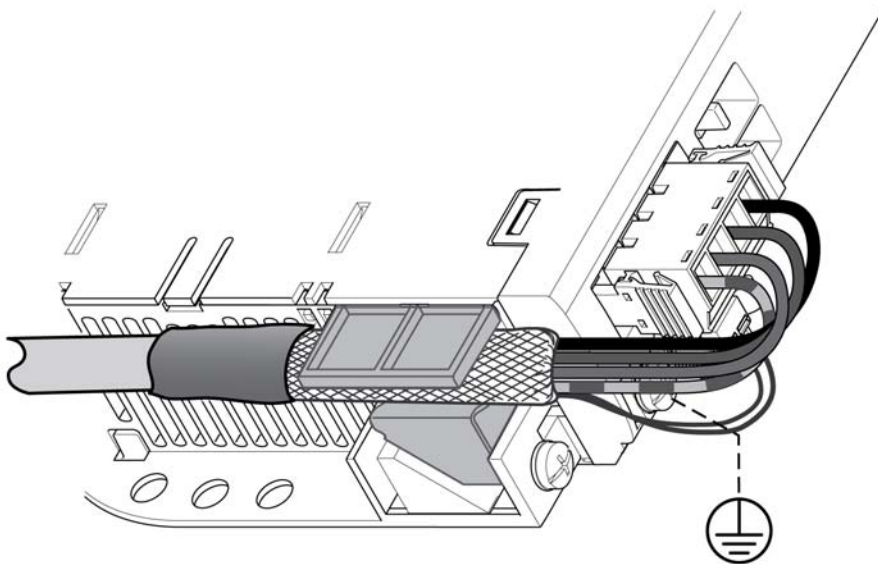

Section 4.2

Maintenance, Repair, Cleaning, Replacement Equipment Inventory

What Is in This Section?

This section contains the following topics:

Topic	Page
Prerequisites for Maintenance, Repair, and Cleaning	94
Machine Repair	96
Cleaning	98
Replacement Equipment Inventory	98

Prerequisites for Maintenance, Repair, and Cleaning

Introduction

Observe the following instructions before carrying out maintenance on the Lexium 52 Drive System.

De-Energize the System

⚠ DANGER

ELECTRIC SHOCK, EXPLOSION, OR ARC FLASH

- Disconnect all power from all equipment including connected devices prior to removing any covers or doors, or installing or removing any accessories, hardware, cables, or wires.
- Place a "Do Not Turn On" or equivalent hazard label on all power switches and lock them in the non-energized position.
- Wait 15 minutes to allow the residual energy of the DC bus capacitors to discharge.
- Measure the voltage on the DC bus with a properly rated voltage sensing device and verify that the voltage is less than 42.4 Vdc.
- Do not assume that the DC bus is voltage-free when the DC bus LED is off.
- Block the motor shaft to prevent rotation prior to performing any type of work on the drive system.
- Do not create a short-circuit across the DC bus terminals or the DC bus capacitors.
- Replace and secure all covers, accessories, hardware, cables, and wires and confirm that a proper ground connection exists before applying power to the unit.
- Use only the specified voltage when operating this equipment and any associated products.

Failure to follow these instructions will result in death or serious injury.

How to de-energize the system:

Step	Action
1	Set main switch to OFF position, or otherwise disconnect all power to the system.
2	Prevent main switch from being switched back on.
3	In the case of any drives, servos or other equipment with high capacity capacitors, wait at least 15 minutes after removing power (switching off) to allow the DC bus capacitors to discharge.
4	Verify whether the DC-BUS LED indicator has turned off on the Lexium 52.
5	Verify DC+ to PE (Protective Earth/ground) and DC- to PE with an appropriate measuring instrument to make sure that it is de-energized before working on the device.

⚠ DANGER**ELECTRIC SHOCK, EXPLOSION OR ARC FLASH**

Verify with a correctly calibrated measuring instrument that the DC bus is de-energized (less than 42.4 Vdc) before replacing, maintaining or cleaning machine components.

Failure to follow these instructions will result in death or serious injury.

Help in Case of an Unforeseen Issue

If...	Then...
The DC bus does not discharge completely	Do not repair or operate the Lexium 52.
	Contact the Schneider Electric contact partner.

Machine Repair

Presentation

When replacing Lexium 52, be sure to observe the important safety information in the sections of the present document concerning mounting and dismantling components.

DANGER

ELECTRIC SHOCK CAUSED BY HIGH LEAKAGE (TOUCH) VOLTAGE

- Before working on the product, make sure that it is de-energized.
- After disconnection, do not touch connector CN1 mains connection on the Lexium 52 as it still carries hazardous voltages for approximately one second.
- Only operate the Lexium 52 in a control cabinet that cannot be opened without the help of tools.

Failure to follow these instructions will result in death or serious injury.

There are no other user-serviceable parts within the Lexium 52. Either replace the entire drive or contact Schneider Electric (*see page 136*).

WARNING

UNINTENDED EQUIPMENT OPERATION

- Only use software and hardware components approved by Schneider Electric for use with this equipment.
- Do not attempt to service this equipment outside of authorized Schneider Electric service centers.
- Update your application program every time you change the physical hardware configuration.

Failure to follow these instructions can result in death, serious injury, or equipment damage.

Use only the accessories and mounting parts specified in the documentation and no third-party devices or components that have not been expressly approved by Schneider Electric. Do not modify the equipment.

In case machine repair includes the replacement of the drive components, observe the following instructions for ESD protection in order to avoid any damage due to electrostatic discharge:

NOTICE

ELECTROSTATIC DISCHARGE

- Do not touch any of the electrical connections or components.
- Prevent electrostatic charges, for example, by wearing appropriate clothing.
- If you must touch circuit boards, do so only on the edges.
- Move the circuit boards as little as possible.
- Remove existing static charge by touching a grounded, metallic surface.

Failure to follow these instructions can result in equipment damage.

Cleaning

To Clean the Lexium 52

Care must be taken with cleaning products as some active agents may have deleterious effects on plastics and stainless steel welds.

NOTICE

CORROSION CAUSED BY CLEANING AGENTS

- Before using a cleaning agent, carry out a compatibility test in relation to the cleaning agent and the component affected.
- Do not use alkaline detergent as the polycarbonate can lose its stability if you come into contact with it.
- Do not use any chlorid-containing cleaning agents as these corrode the stainless steel and in particular the welds, and thus reduce the strength of the mechanics.

Failure to follow these instructions can result in equipment damage.

For more information on the material properties of your component, refer to Mechanical and Electrical Data (*see page 126*).

Replacement Equipment Inventory

Presentation

Keep a stock of the most important components to make certain your machine is functioning and ready for operation.

Replace devices with the same hardware configuration to help ensure compatibility.

Indicate the following information on the replacement equipment order:

- Unicode: **LXM52DU60C**
- Hardware revision: for example, **RS:02**

This information can be found on the logistic nameplate (*see page 30*).

For more information concerning the replacement of components, refer to Replacing Components and Cables (*see page 99*).

Section 4.3

Replacing Components and Cables

What Is in This Section?

This section contains the following topics:

Topic	Page
Prerequisites for Replacing Components and Cables	100
Component Replacement	103
Cable Replacement	105

Prerequisites for Replacing Components and Cables

De-Energize the System

 **DANGER**

ELECTRIC SHOCK, EXPLOSION, OR ARC FLASH

- Disconnect all power from all equipment including connected devices prior to removing any covers or doors, or installing or removing any accessories, hardware, cables, or wires.
- Place a "Do Not Turn On" or equivalent hazard label on all power switches and lock them in the non-energized position.
- Wait 15 minutes to allow the residual energy of the DC bus capacitors to discharge.
- Measure the voltage on the DC bus with a properly rated voltage sensing device and verify that the voltage is less than 42.4 Vdc.
- Do not assume that the DC bus is voltage-free when the DC bus LED is off.
- Block the motor shaft to prevent rotation prior to performing any type of work on the drive system.
- Do not create a short-circuit across the DC bus terminals or the DC bus capacitors.
- Replace and secure all covers, accessories, hardware, cables, and wires and confirm that a proper ground connection exists before applying power to the unit.
- Use only the specified voltage when operating this equipment and any associated products.

Failure to follow these instructions will result in death or serious injury.

How to de-energize the system:

Step	Action
1	Set main switch to OFF position, or otherwise disconnect all power to the system.
2	Prevent main switch from being switched back on.
3	In the case of any drives, servos or other equipment with high capacity capacitors, wait at least 15 minutes after removing power (switching off) to allow the DC bus capacitors to discharge.
4	Verify whether the DC-BUS LED indicator has turned off on the Lexium 52.
5	Verify DC+ to PE (Protective Earth/ground) and DC- to PE with an appropriate measuring instrument to make sure that it is de-energized before working on the device.

 **DANGER**

ELECTRIC SHOCK, EXPLOSION OR ARC FLASH

Verify with a correctly calibrated measuring instrument that the DC bus is de-energized (less than 42.4 Vdc) before replacing, maintaining or cleaning machine components.

Failure to follow these instructions will result in death or serious injury.

Other Prerequisites

DANGER

ELECTRIC SHOCK, EXPLOSION, OR ARC FLASH

- Operate electrical components only with a connected protective ground (earth) cable.
- After the installation, verify the secure connection of the protective ground (earth) cable to all electrical devices to ensure that connection complies with the connection diagram.
- Before enabling the device, safely cover the live components to prevent contact.
- Do not touch the electrical connection points of the components when the module is energized.
- Provide protection against indirect contact (EN 50178).
- Connect and disconnect cables and terminals only after you have verified that the power has been removed from the system.
- Insulate the unused conductors on both ends of the motor cable.

Failure to follow these instructions will result in death or serious injury.

There are no other user-serviceable parts within the Lexium 52. Either replace the entire drive or contact Schneider Electric (*see page 136*).

WARNING

UNINTENDED EQUIPMENT OPERATION

- Only use software and hardware components approved by Schneider Electric for use with this equipment.
- Do not attempt to service this equipment outside of authorized Schneider Electric service centers.
- Update your application program every time you change the physical hardware configuration.

Failure to follow these instructions can result in death, serious injury, or equipment damage.

WARNING

IMPROPER REPLACEMENT OR OPENING OF THE COMPONENT HOUSING

- Do not open the housing of the components for commissioning, replacement, or any other reason whatsoever unless otherwise instructed in the specific product documentation of the component.
- Observe and respect the instructions and specifications contained in the product documentation and that of the machine manufacturer when replacing components.
- Replace inoperable components as a whole.

Failure to follow these instructions can result in death, serious injury, or equipment damage.

The metal surfaces of the product may exceed 65 °C (149 °F) (for bare metal) during operation.

 WARNING
<p>HOT SURFACES</p> <ul style="list-style-type: none"> ● Avoid unprotected contact with hot surfaces. ● Do not allow flammable or heat-sensitive parts in the immediate vicinity of hot surfaces. ● Verify that the heat dissipation is sufficient by performing a test run under maximum load conditions. <p>Failure to follow these instructions can result in death, serious injury, or equipment damage.</p>

Help in Case of an Unforeseen Issue

If...	Then...
The DC bus does not discharge completely	Do not repair or operate Lexium 52.
	Contact the Schneider Electric contact partner.

For more information on the DC bus LED indicator, refer to Indicators of the Controller *(see page 110)*.

Component Replacement

How to Replace a Lexium 52 Drive System Component

Before beginning the replacement of specific components, read thoroughly the Prerequisites for Replacing Components and Cables (*see page 100*) for important safety information.

DANGER

ELECTRIC SHOCK, EXPLOSION, OR ARC FLASH

- Disconnect all power from all equipment including connected devices prior to removing any covers or doors, or installing or removing any accessories, hardware, cables, or wires.
- Place a "Do Not Turn On" or equivalent hazard label on all power switches and lock them in the non-energized position.
- Wait 15 minutes to allow the residual energy of the DC bus capacitors to discharge.
- Measure the voltage on the DC bus with a properly rated voltage sensing device and verify that the voltage is less than 42.4 Vdc.
- Do not assume that the DC bus is voltage-free when the DC bus LED is off.
- Block the motor shaft to prevent rotation prior to performing any type of work on the drive system.
- Do not create a short-circuit across the DC bus terminals or the DC bus capacitors.
- Replace and secure all covers, accessories, hardware, cables, and wires and confirm that a proper ground connection exists before applying power to the unit.
- Use only the specified voltage when operating this equipment and any associated products.

Failure to follow these instructions will result in death or serious injury.

Step	Action
1	Disconnect all connection cables on the device that shall be replaced.
2	Respectively undo screwed connections to the device mounting on the device rear wall (heat sink) at the top end and bottom end. For important safety information, follow the instructions in the safety messages after this table.
3	Remove the Lexium 52 component and replace it.
4	Install the new Lexium 52 component and tighten the screwed connections on the top and bottom side.
5	Connect the Lexium 52 component according to the circuit diagram of the machine. For important safety information, follow the instructions in the safety messages after this table.
6	After replacing a Lexium 52 component, proceed as by the first commissioning.

 **DANGER**

INCORRECT ASSIGNMENT OF CABLES

Verify that the assignment of the cables conforms to their previous connector assignments.

Failure to follow these instructions will result in death or serious injury.

 **CAUTION**

FALLING HEAVY OBJECT

Do not fully remove the screw connections of the device mounting suspension and prevent the device from falling out and down.

Failure to follow these instructions can result in injury or equipment damage.

NOTE: After each replacement of a safety component, verify the wiring (for further information, refer to Application Proposals (*see page 70*)).

Cable Replacement

Introduction

NOTE: In addition to the following instructions, you must observe the specifications of the machine manufacturer when replacing the cables.

De-Energize the System

⚠ DANGER

ELECTRIC SHOCK, EXPLOSION, OR ARC FLASH

- Disconnect all power from all equipment including connected devices prior to removing any covers or doors, or installing or removing any accessories, hardware, cables, or wires.
- Place a "Do Not Turn On" or equivalent hazard label on all power switches and lock them in the non-energized position.
- Wait 15 minutes to allow the residual energy of the DC bus capacitors to discharge.
- Measure the voltage on the DC bus with a properly rated voltage sensing device and verify that the voltage is less than 42.4 Vdc.
- Do not assume that the DC bus is voltage-free when the DC bus LED is off.
- Block the motor shaft to prevent rotation prior to performing any type of work on the drive system.
- Do not create a short-circuit across the DC bus terminals or the DC bus capacitors.
- Replace and secure all covers, accessories, hardware, cables, and wires and confirm that a proper ground connection exists before applying power to the unit.
- Use only the specified voltage when operating this equipment and any associated products.

Failure to follow these instructions will result in death or serious injury.

How to de-energize the system:

Step	Action
1	Set main switch to OFF position, or otherwise disconnect all power to the system.
2	Prevent main switch from being switched back on.
3	In the case of any drives, servos or other equipment with high capacity capacitors, wait at least 15 minutes after removing power (switching off) to allow the DC bus capacitors to discharge.
4	Verify whether the DC-BUS LED indicator has turned off on the Lexium 52.
5	Verify DC+ to PE (Protective Earth/ground) and DC- to PE with an appropriate measuring instrument to make sure that it is de-energized before working on the device.

⚠ DANGER

ELECTRIC SHOCK, EXPLOSION OR ARC FLASH

Verify with a correctly calibrated measuring instrument that the DC bus is de-energized (less than 42.4 Vdc) before replacing, maintaining or cleaning machine components.

Failure to follow these instructions will result in death or serious injury.

Help in Case of an Unforeseen Issue:

If...	Then...
The DC bus does not discharge completely	Do not repair or operate the Lexium 52.
	Contact the Schneider Electric contact partner.

Procedure

Proceed as follows for cable replacement:

- Be sure that the cables clearly indicate their connections before disconnecting.
- Replace cables with an identical type and length.
- Refer to any documentation from the original machine manufacturer before replacing cables.
- Disconnect/Attach the cable from the equipment components involved.

⚠ DANGER

INCORRECT ASSIGNMENT OF CABLES

Verify that the assignment of the cables conforms to their previous connector assignments.

Failure to follow these instructions will result in death or serious injury.

Chapter 5

Indicators and Control Elements

Indicators and Control Elements

Overview

The display of the Lexium 52 consists of four LED indicators that are used to display status information.

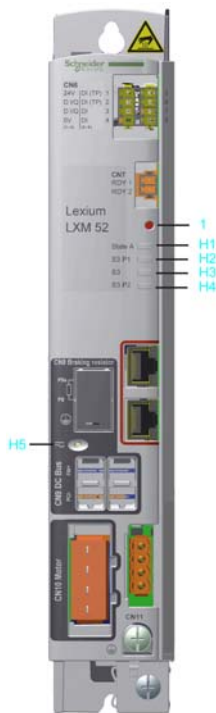

- 1 Reset button
- H1 **State A** LED indicator
- H2 **S3 P1** LED indicator for the status of port 1 of the Sercos III communication
- H3 **S3** LED indicator for the Sercos III communication
- H4 **S3 P2** LED indicator for the status of port 2 of the Sercos III communication
- H5 DC Bus LED indicator

Reset Button

Press the reset button to reset and reboot the Lexium 52.

State A LED Indicator

LED indicator color / status	Description	Instructions / information for the user
Off	Device is not energized or is otherwise inoperable.	<ul style="list-style-type: none"> • Verify the power supply. • Replace device.
Flashing green (4 Hz, 125 ms)	Initialization of the device (firmware boot process, compatibility verification of the hardware, updating the firmware)	<ul style="list-style-type: none"> • Waiting until initialization is complete.
Flashing slowly green (2 Hz, 250 ms)	Identification of the device	<ul style="list-style-type: none"> • If necessary, identify the device via SoMachine Motion as defined by the controller configuration.
Steady green	Device has been initialized and waits for the configuration.	<ul style="list-style-type: none"> • Configure device as active. • Configure device as inactive. • Configure device for the execution of motions.
Steady red	A non-recoverable error has been detected requiring user intervention: <ul style="list-style-type: none"> • Watchdog • Firmware • Checksum • Internal error detected 	<ul style="list-style-type: none"> • Power off / on (power reset) • If this condition persists, replace the device.
Flashing slowly red (2 Hz, 250 ms)	A general error has been detected.	<ul style="list-style-type: none"> • The configuration shows the detected error • Reset error detected in the SoMachine Motion Logic Builder menu Online → Reset diagnostic messages of controller. • Otherwise restart device.

Port LED Indicators

LED indicator color / status	Description
Off	No cable connected
Steady orange	Cable connected, no Sercos communication
Steady green	Cable connected, active Sercos communication

S3 LED Indicator

LED indicator color / status	Description	Instructions / information for the user
Off	The device is not energized or is otherwise inoperable, or there is no communication due to an interrupted or separated connection.	Sercos boot-up or hot swap
Steady green	Active Sercos connection without an error detected in the CP4.	–
Flashing green (4 Hz, 125 ms)	The device is in loopback mode. Loopback describes the situation in which the Sercos telegrams have to be sent back on the same port on which they were received. Possible causes: <ul style="list-style-type: none"> ● Line topology or ● Sercos loop break 	Workaround: <ul style="list-style-type: none"> ● Close ring. Reset condition: <ul style="list-style-type: none"> ● Acknowledge the detected error in the SoMachine Motion Logic Builder menu Online → Reset diagnostic messages of controller. ● Switch from CP0 to CP1 alternatively. NOTE: If during phase CP1 a line topology or ring break was detected (device in loopback mode), the LED indicator condition does not change.
Steady red	Sercos diagnostic class 1 (DC1) error has been detected on port 1 and/or port 2.	Reset condition: <ul style="list-style-type: none"> ● Acknowledge the detected error in the SoMachine Motion Logic Builder menu Online → Reset diagnostic messages of controller.
Flashing red / green (4 Hz, 125 ms)	Communication error has been detected. Possible causes: <ul style="list-style-type: none"> ● Improper functioning of the telegram ● CRC error detected 	Reset condition: <ul style="list-style-type: none"> ● The configuration shows which error has been detected. ● Acknowledge the detected error in the SoMachine Motion Logic Builder menu Online → Reset diagnostic messages of controller.
Steady orange	The device is in a communications phase CP0 up to and including CP3 or HP0 up to and including HP2. Sercos telegrams are received.	–
Flashing orange (4 Hz, 125 ms)	Device identification	NOTE: The identified device is also displayed by the axis state LED indicator on the drive.

DC Bus LED Indicator

LED indicator color / status	Description	Information
Off	DC bus supply inactive	–
Steady red	DC bus supply active	–

The DC Bus LED is not an indicator for the absence of DC bus voltage.

Chapter 6

Integrated Communication Ports

What Is in This Chapter?

This chapter contains the following topics:

Topic	Page
Electrical Connections Overview	112
Connection Details	115

Electrical Connections Overview

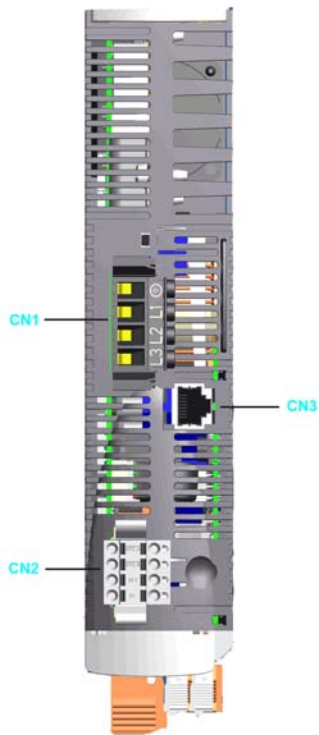

Top Side

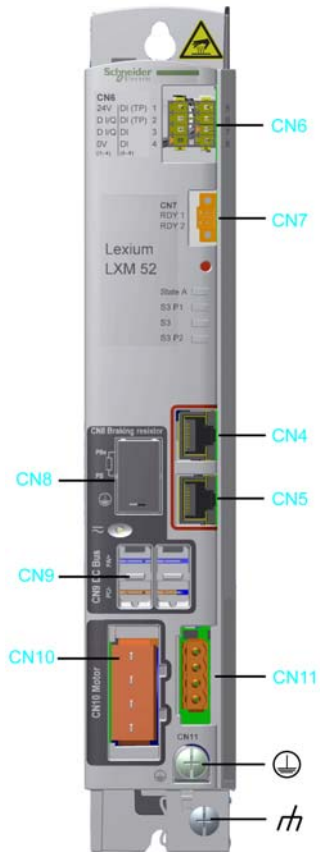

Connection	Meaning	Connection cross-section [mm ²] / [AWG]	Tightening torque [Nm] / [lbf in]
CN1	Mains connection	0.75...5.3 / 18...10 ⁽¹⁾	0.68 / 6.0
		0.75...10 / 18...8 ⁽²⁾	1.81 / 16.02
CN2	24 V control supply and safety function STO	0.5...2.5 / 20...14	–
CN3	Motor encoder	–	–
(1) These values apply to LXM52DU60C, LXM52DD12C, LXM52DD18C, LXM52DD30C. (2) These values apply to LXM52DD72C.			

Front Panel



Connection	Meaning	Connection cross-section [mm ²] / [AWG]	Tightening torque [Nm] / [lbf in]
CN4	Sercos, port 1	–	–
CN5	Sercos, port 2	–	–
CN6	Digital inputs/outputs	0.25...1.5 / 24...16	–
CN7	Ready	0.2...1.5 / 24...16	–
CN8	External braking resistor	0.75...3.3 / 18...12	0.51 / 4.5
CN9	DC bus connection for parallel operation	Use the prefabricated cables VW3M7101R01.	–
CN10	Motor phases	0.75...5.3 / 18...10 ⁽¹⁾	0.68 / 6.0
		0.75...10 / 18...8 ⁽²⁾	0.68 / 6.0
CN11	Holding brake / motor temperature	0.75...2.5 / 18...14	–
	Protective conductor ⁽³⁾	min. 10 / 6	3.5 / 31.0
	Shield connection motor cable	Locking screw for the shield terminal ⁽⁴⁾	–
<p>(1) These values apply for the LXM52DU60C, LXM52DD12C, LXM52DD18C, LXM52DD30C. (2) These values apply for the LXM52DD72C. (3) Connect the ground connection of the device to the ground neutral point of the system. (4) Attach the cable shield across a large surface in the shield terminal.</p>			

Connection Details

CN1 - Mains Connection (Power Stage Supply)

The Lexium 52 is supplied with voltage via the power connection. The rated voltage is 208...480 V.



Electrical connection - mains connection (power stage supply)

Pin	Designation	Meaning
1		Protective ground conductor
2	L1	External conductor L1
3	L2	External conductor L2
4	L3	External conductor L3

CN2 - Connection for 24 V Control Supply and Safety Function STO

The 24 V input supplies the internal logic assemblies as well as the holding brakes of the complete axis group, connected to the axis modules.

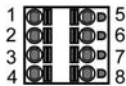

CN2 Connection for 24 V control supply and safety function STO

Pin	Designation	Meaning
1	STO_A	InverterEnable signal A
2	STO_B	InverterEnable signal B
3	24 V	Supply voltage Lexium 52 - Input
4	0V	Supply voltage Lexium 52 - Input
5	STO_A	Inverter enable signal A, jumpered with pin 1
6	STO_B	Inverter enable signal B, jumpered with pin 2
7	24 V	Supply voltage for optional external holding brake - output, jumpered with pin 3.
8	0V	Supply voltage for optional external holding brake - output, jumpered with pin 4.

NOTE: The maximum terminal current is 16 A. Note the maximum permissible terminal current when connecting several Lexium 52.

CN3 - Motor Encoder

At the motor encoder connection, the measuring system, which records the axis position, is connected.

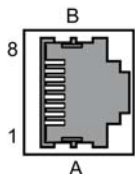

CN3 - motor encoder

Pin	Designation	Meaning
1	Cos	Cosine track axis A/B
2	RefCos	Reference signal cosine axis A/B
3	Sin	Sine track axis A/B
4	RS485+	Positive RS-485 signal axis A/B
5	RS485-	Negative RS-485 signal axis A/B
6	RefSin	Reference signal sine axis A/B
7	N.C.	Reserved
8	N.C.	Reserved
A	P10V	Supply voltage encoder A/B
B	GND	Mass A/B

NOTE: By usage of the 5 V encoder adapter it is also possible to connect encoder with 5 V supply voltage to the drive.

CN4/CN5 - Sercos

The Sercos connection is used for communication between the controller and the drive.

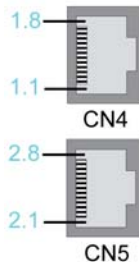

Electrical connection - Sercos

Pin	Designation	Meaning
1.1	Eth0_Tx+	Positive transmission signal
1.2	Eth0_Tx-	Negative transmission signal
1.3	Eth0_Rx+	Positive receiver signal
1.4	N.C.	Reserved
1.5	N.C.	Reserved
1.6	Eth0_Rx-	Negative receiver signal
1.7	N.C.	Reserved
1.8	N.C.	Reserved
2.1	Eth1_Tx+	Positive transmission signal
2.2	Eth1_Tx-	Negative transmission signal
2.3	Eth1_Rx+	Positive receiver signal
2.4	N.C.	Reserved
2.5	N.C.	Reserved
2.6	Eth1_Rx-	Negative receiver signal
2.7	N.C.	Reserved
2.8	N.C.	Reserved

CN6 - Digital Inputs / Outputs

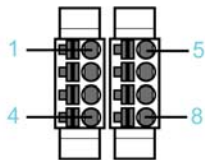

CN6 - digital inputs / outputs

Pin	Designation	Meaning
1	24 V	24 V
2	D I/Q	Digital input 4 / digital output 0
3	D I/Q	Digital input 5 / output 1
4	0 V	0 V
5	DI (TP)	Digital input 0 / TP 0
6	DI (TP)	Digital input 1 / TP 1
7	DI	Digital input 2
8	DI	Digital input 3

CN7 - Ready Relay Output

When the drive is ready for operation, the Ready contact is activated.

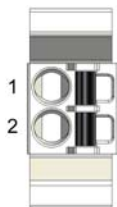

Electrical connection - Ready relay output

Pin	Designation	Meaning	Note
1	RDY1	Ready contact	Potential-free contact
2	RDY2	Ready contact	Potential-free contact

CN8 - Connection External Braking Resistor

If the internal braking resistor is not sufficient, you can connect an external braking resistor to this connection.

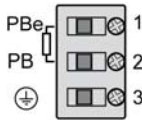

Electrical connection - external braking resistor

Pin	Designation	Meaning
1	PBe	Connection for external resistor
2	PB	Connection for external resistor
3		Protective ground conductor

For further information, refer to:

- The technical data specified for external braking resistors (*see page 126*).
- The configuration of parameters within the parameter group `ExternalBrakingResistor` in SoMachine Motion. (See the SoMachine Motion Online Help, section *Drive Systems and Motors --> Lexium 52 stand-alone drive system and motors --> Lexium 52 device objects and parameters --> Lexium LXM52 Drive --> External Braking Resistor*.)
- For further information about the available external braking resistors see catalogue "PacDrive 3 automation solution Lexium 52 stand-alone servo drive" at Schneider Electric website.

CN9 - Connection for DC Bus Connection

DC buses can be connected via this connection.



Electrical connection - DC bus connection

Pin	Designation	Meaning
1	PA/+	Positive connection for DC bus
2	PC/-	Negative connection for DC bus

CN10 - Connection for the Motor Phases

The motor signals U, V, and W supply the motor with the required energy.

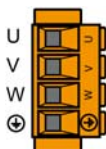

Electrical connection - holding brake motor, temperature motor

Motor cable ⁽¹⁾		Motor connectors	Meaning
Label of cable core	Color of cable core	Label	
1	Black	U	Motor phase U
2	Black	V	Motor phase V
3	Black	W	Motor phase W
-	Green/Yellow		Protective conductor protective earth ground

(1) Order numbers: VW3E1143Rxxx, VW3E1144Rxxx, VW3E1145Rxxx

The insulation-stripped length of the wires of the motor connector is 15 mm (0.59 in.). The maximum length of the motor supply cable is 75 m (246.06 ft).

CN11 - Holding Brake Motor, Temperature Motor

The temperature signals are connected to a temperature sensor to measure the temperature of the motor. The holding brake output supplies the holding brake in the motor with the required energy.

The device monitors the motor phases for:

- Short circuit between the motor phases.
- Short circuit between the motor phases and ground.

Short circuits between the motor phases and the DC bus, the braking resistor, or the holding brake wires are not detected.

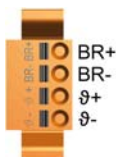

Electrical connection - motor phases

Motor cable ⁽¹⁾		Motor connectors	Meaning
Label of cable core	Color of cable core	Label	
5	Black	1 ϑ-	Temperature negative signal
6	Black	ϑ+	Temperature positive signal
7	Black	BR-	Holding brake negative connection ⁽²⁾
8	Black	BR+	Holding brake positive connection ⁽²⁾
(1) Order numbers: VW3E1143Rxxx, VW3E1144Rxxx, VW3E1145Rxxx (2) The maximum terminal current is 1.7 A.			

The insulation-stripped length of the wires of the motor connector is 15 mm (0.59 in.). The maximum length of the motor supply cable is 75 m (246.06 ft).

Chapter 7

Technical Data

What Is in This Chapter?

This chapter contains the following topics:

Topic	Page
Ambient Conditions	124
Standards and Regulations	125
Mechanical and Electrical Data	126
Dimensions	131

Ambient Conditions

Overview

Ambient conditions Lexium 52:

Procedure	Parameter	Value	Basis
Operation	Class 3K3		IEC/EN 60721-3-3
	Degree of protection housing	IP 20 with plug-in-connectors	
	Supplemental degree of protection of installed product	IP 54	
	Pollution degree	2	
	Ambient temperature	0...+45 °C / +32...113 °F	
	● Condensation	No	
	● Icing	No	
	● Other liquid	No	
	Relative humidity	5%...95%	
	Class 3M3		
	Shock	100 m/s ²	
	Vibration	10 m/s ²	
Transport	Class 2K3		IEC/EN 60721-3-2
	Ambient temperature	-25...+70 °C / -13...+158 °F	
	● Condensation	No	
	● Icing	No	
	● Other liquid	No	
	Relative humidity	5%...95%	
	Class 2M2		
	Shock	300 m/s ²	
	Vibration	10 m/s ²	
Long-term storage in transport packaging	Class 1K4		IEC/EN 60721-3-1
	Ambient temperature	-25...+55 °C / -13...+131 °F	
	● Condensation	No	
	● Icing	No	
	● Other liquid	No	
	Relative humidity	5%...95%	

Installation Altitude

The installation altitude is defined as height above sea level.

Installation altitude without power reduction	<1000 m (<3281 ft)
Installation altitude while complying with all of the following conditions: <ul style="list-style-type: none"> ● 55 °C (131 °F) maximum ambient temperature ● Reduction of the continuous power by 1% per 100 m (328 ft.) above 1000 m (3281 ft.) 	1000...2000 m (3281...6562 ft.)
Installation altitude above sea level when complying with all of the following conditions: <ul style="list-style-type: none"> ● 40 °C (104 °F) maximum ambient temperature ● Reduction of the continuous power by 1 % per 100 m (328 ft.) above 1000 m (3281 ft.) ● Overvoltages of the supplying grid limited to an overvoltage category III according to IEC 60664-1/IEC 61800-5-1 	2000...3000 m (6562...9843 ft.)

Degree of Protection When Using the Safety Function

Ensure that no conductive pollution can deposit in the product (pollution degree 2). Conductive pollution can cause the safety function to be ineffective.

Standards and Regulations

Overview

Standards and regulations

CE	Low Voltage Directive 2014/35/EU <ul style="list-style-type: none"> ● EN 61800-5:2007
	EMC Directive 2014/30/EU <ul style="list-style-type: none"> ● EN 61800-3:2004 + A1:2012
UL	UL 508C Power Conversion Equipment
CSA	Industrial Control Equipment <ul style="list-style-type: none"> ● CSA-C22.2 No. 14

Standards and regulations - functional safety

Functional safety	EN ISO 13849-1, PL e, Category 3 EN 62061, SIL 3 EN 61508, SIL 3
-------------------	--

Mechanical and Electrical Data

Technical Data Lexium 52

Designation	Parameter	Value				
Product configuration	Item name	LXM52DU60 C	LXM52DD12 C	LXM52DD18 C	LXM52DD30C	LXM52DD72 C
Power supply	Rated supply voltage $\mathfrak{3}_{AC}$	208...480 V				
	Supply frequency	50 (-5%)...60 Hz (+5%)				
	Input current	1.8 A	3.4 A	6.9 A	11.1 A	22.5 A
	DC bus voltage	294...679 Vdc				
	DC bus capacity	110 μ F	195 μ F	390 μ F	560 μ F	1120 μ F
	Overvoltage	820 Vdc				
Logic supply	Control voltage / control current (without holding brake)	24 Vdc (-15...+20%)				
		<1 A	<1 A	<1 A	<1 A	<1 A
	Control voltage / control current (with holding brake)	24 Vdc (-10...+6%)				
		2.7 A	2.7 A	2.7 A	2.7 A	2.7 A
	Maximum terminal current	16 A				
Motor connection	Rated current (8 kHz) by 50 °C (122 °F)	1.5 A _{eff}	3.0 A _{eff}	6.0 A _{eff}	10.0 A _{eff}	24.0 A _{eff}
	Peak current (8 kHz) by 50 °C (122 °F)	6.0 A _{eff}	12.0 A _{eff}	18.0 A _{eff}	30.0 A _{eff}	72.0 A _{eff}
	Rated power without mains line reactor	0.4 kW	0.9 kW	1.8 kW	3.0 kW	7.0 kW
	Rated power with mains line reactor	0.8 kW	1.6 kW	3.3 kW	5.6 kW	13 kW
	Maximum length of the motor cable	75 m (246.06 ft)				
<p>(1) The maximum specified braking resistor can derate the peak power of the device. Depending on the application, it is possible to use a resistor with a higher ohm value.</p> <p>(2) Time between shutdown cycles: > 1 s</p> <p>(3) In the case of a disconnection time of 100 ms</p>						

Designation	Parameter	Value				
Product configuration	Item name	LXM52DU60 C	LXM52DD12 C	LXM52DD18 C	LXM52DD30C	LXM52DD72 C
Power loss	Power unit without mains line reactor	17 W	37 W	68 W	115 W	283 W
	Power unit with mains line reactor	19 W	40 W	74 W	125 W	308 W
Internal braking resistor	Resistance	132 Ω	60 Ω	30 Ω	30 Ω	10 Ω
	Continuous power	20 W	40 W	60 W	100 W	150 W
	Peak energy E_{CR}	200 Ws	400 Ws	600 Ws	1000 Ws	2400 Ws
External braking resistor	Minimum resistance	70 Ω	47 Ω	25 Ω	15 Ω	8 Ω
	Maximum resistance ⁽¹⁾	145 Ω	73 Ω	50 Ω	30 Ω	12 Ω
	Maximum power	200 W	500 W	800 W	1500 W	3000 W
Interface	Sercos	Integrated				
Encoder	Power supply	10 Vdc (-5...+5%), maximum 125 mA, short-circuit-proof				
	Differential analog input (sine and cosine signal)	Input voltage: 0.8...1.1 VPP				
		Offset: 2.5 Vdc (-10...+10%)				
		Terminating resistor: 130 Ω				
	Cutoff-frequency: 100 MHz					
	Communication	RS-485 interface				
<p>(1) The maximum specified braking resistor can derate the peak power of the device. Depending on the application, it is possible to use a resistor with a higher ohm value.</p> <p>(2) Time between shutdown cycles: > 1 s</p> <p>(3) In the case of a disconnection time of 100 ms</p>						

Designation	Parameter	Value				
Product configuration	Item name	LXM52DU60 C	LXM52DD12 C	LXM52DD18 C	LXM52DD30C	LXM52DD72 C
Digital inputs/outputs	Voltage	24 Vdc (-20...+25%)				
	Power	maximum current consumption 1 A				
	Digital inputs or TP	2 inputs with switching level Type 1 according to EN61131-2				
		Low level: -3...5 Vdc				
		High level: 15...30 Vdc				
		Filter: 1 ms/5 ms (configurable)				
		Filter for TP: 100 µs/5 ms (configurable)				
	Digital inputs	2 inputs with switching level Type 1 according to EN61131-2				
		Low level: -3 ... 5 Vdc				
		High level: 15...30 Vdc				
		Filter: 1 ms/5 ms (configurable)				
	Digital inputs or digital outputs	2 inputs/outputs (bidirectional)				
		Inputs with switching level Type 1 according to EN61131-2				
		Low level: -3...5 Vdc				
		High level: 15...30 Vdc				
		Filter: 1 ms/5 ms (configurable)				
		Outputs with rated value according to EN61131-2				
High level: $(+VL - 3V) < V_{out} < +VL$						
Output current: maximum 500 mA per output						
<p>(1) The maximum specified braking resistor can derate the peak power of the device. Depending on the application, it is possible to use a resistor with a higher ohm value.</p> <p>(2) Time between shutdown cycles: > 1 s</p> <p>(3) In the case of a disconnection time of 100 ms</p>						

Designation	Parameter	Value					
Product configuration	Item name	LXM52DU60 C	LXM52DD12 C	LXM52DD18 C	LXM52DD30C	LXM52DD72 C	
InverterEnable STO_A, STO_B	Current consumption	$I_{IEmax} = 5 \text{ mA}$					
	Logical 0 (U_{low})	-3...+5 Vdc					
	Logical 1 (U_{high})	+15...+30 Vdc					
	Debouncing time /STO_A and /STO_B	>1 ms					
	Detection of difference in signals between /STO_A and /STO_B	>1 s					
	Reaction time of the safety function STO	≤10 ms					
	Inputs	Number: 2					
		STO active: $-3 \text{ V} \leq U_{IE} \leq 5 \text{ V}$					
Power stage active: $15 \text{ V} \leq U_{IE} \leq 30 \text{ V}$							
Maximum downtime 500 μs at $U_{IE} > 20 \text{ V}$							
Maximum switching frequency of input signal: maximum 1 Hz							
Dimensions	Housing D x W x H	217 x 48 x 270 mm (8.54 x 1.88 in. x 10.62 in.)		217 x 68 mm x 270 mm (8.54 in x 2.67 in x 10.62 in)	217 x 108 mm x 274.1 mm (8.54 in x 4.25 in x 10.78 in)		
Weight	Weight (with packaging)	1.8 kg (2.2 kg)	1.8 kg (2.3 kg)	1.9 kg (2.3 kg)	2.7 kg (3.2 kg)	5.0 kg (5.5 kg)	
Ventilation	Type of fan	No fan	Internal fan				
Radio interference level	-	C3 (IEC/EN 61800-3)					
Overtoltage category	-	III (EN 61800-5-1:2007)					
<p>(1) The maximum specified braking resistor can derate the peak power of the device. Depending on the application, it is possible to use a resistor with a higher ohm value.</p> <p>(2) Time between shutdown cycles: > 1 s</p> <p>(3) In the case of a disconnection time of 100 ms</p>							

Designation	Parameter	Value				
Product configuration	Item name	LXM52DU60 C	LXM52DD12 C	LXM52DD18 C	LXM52DD30C	LXM52DD72 C
Pollution degree	-	2 (EN 91800-5-1:2007)				
Motor brake	Output voltage	Voltage at control supply CN2 minus 0.8 V				
	Output current	1.7 A (maximum)				2.2 A (maximum)
	Energy inductive load ⁽²⁾	1.5 J ⁽³⁾ (maximum)				4.5 J ⁽³⁾ (maximum)
	Overload protection	Yes				
	Short-circuit protection	Yes				
<p>(1) The maximum specified braking resistor can derate the peak power of the device. Depending on the application, it is possible to use a resistor with a higher ohm value.</p> <p>(2) Time between shutdown cycles: > 1 s</p> <p>(3) In the case of a disconnection time of 100 ms</p>						

Dimensions

Dimensions

Dimensions of the Lexium 52:

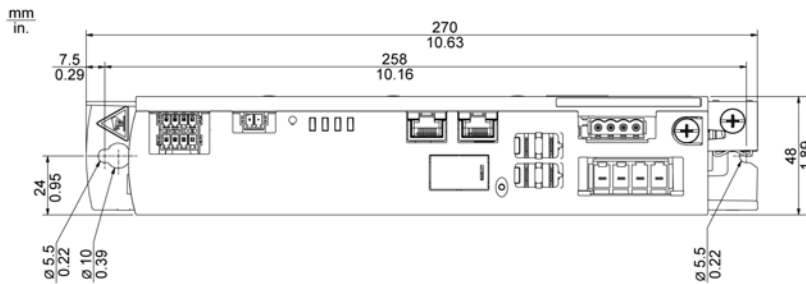
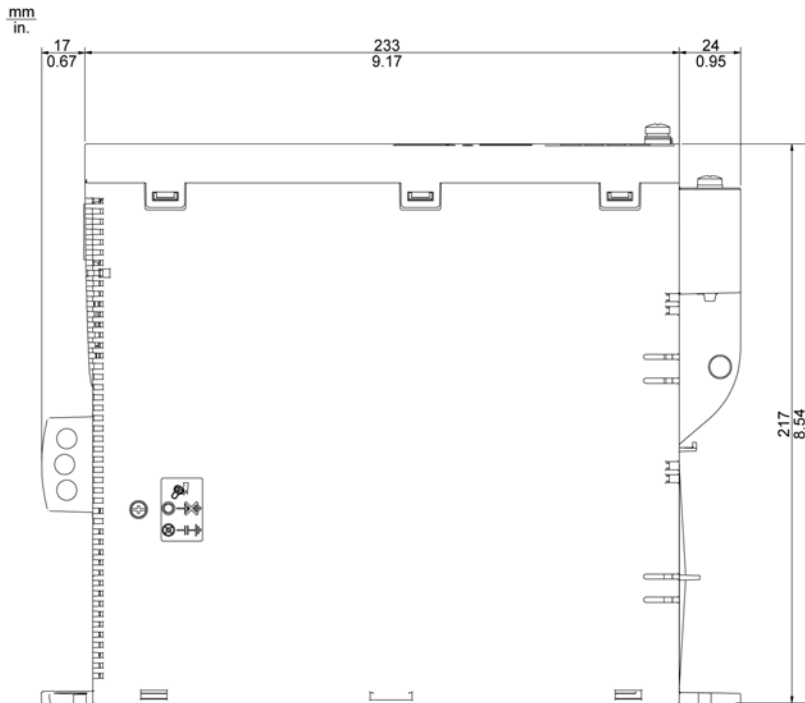

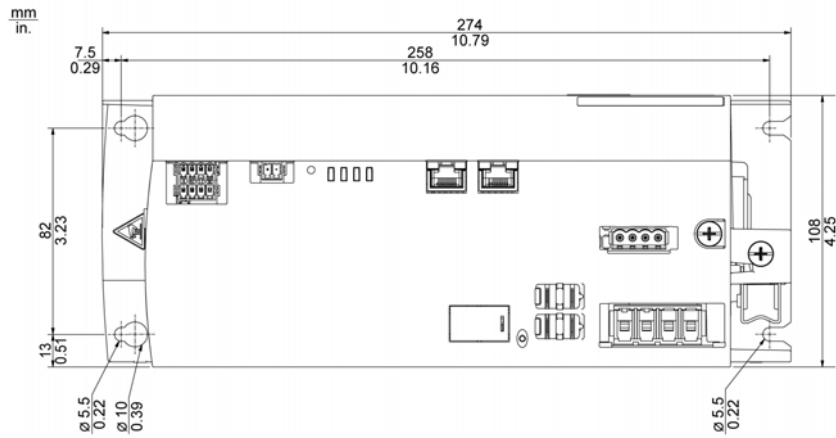
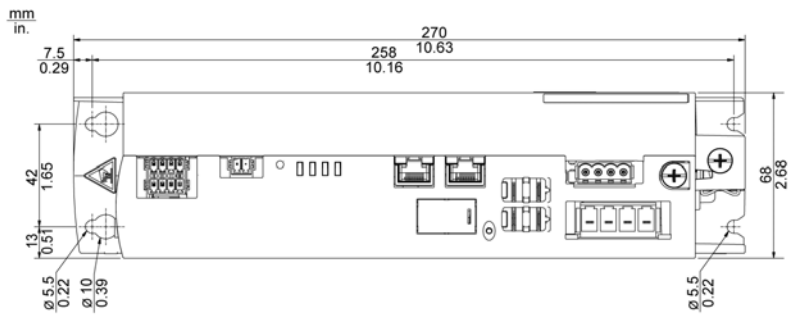

Appendices



What Is in This Appendix?

The appendix contains the following chapters:

Chapter	Chapter Name	Page
A	Further Information on the Manufacturer	135
B	Disposal	137
C	Optional Accessory	139
D	Units and Conversion Tables	147

Appendix A

Further Information on the Manufacturer

What Is in This Chapter?

This chapter contains the following topics:

Topic	Page
Contact Addresses	136
Product Training Courses	136

Contact Addresses

Schneider Electric Automation GmbH

Schneiderplatz 1
97828 Marktheidenfeld, Germany
Phone: +49 (0) 9391 / 606 - 0
Fax: +49 (0) 9391 / 606 - 4000
Email: info-marktheidenfeld@schneider-electric.com
Internet: www.schneider-electric.com

Machine Solution Service

Schneiderplatz 1
97828 Marktheidenfeld, Germany
Phone: +49 (0) 9391 / 606 - 3265
Fax: +49 (0) 9391 / 606 - 3340
Email: automation.support.de@schneider-electric.com
Internet: www.schneider-electric.com

Additional Contact Addresses

See the homepage for additional contact addresses:

www.schneider-electric.com

Product Training Courses

Product Training Courses

Schneider Electric offers a number of product training courses.

The Schneider Electric training instructors will help you take advantage of the extensive possibilities offered by the system.

See the website (www.schneider-electric.com) for further information and the seminar schedule.

Appendix B

Disposal

Disposal

Information on the Disposal of Schneider Electric Products

NOTE: The components consist of different materials which can be recycled and must be disposed of separately.

Step	Action
1	Dispose of the packaging in accordance with the relevant national regulations.
2	Dispose of the packaging at the disposal sites provided for this purpose.
3	Dispose of Lexium 52 in accordance with the applicable national regulations.

Appendix C

Optional Accessory

Section C.1

5V Encoder Adapter

What Is in This Section?

This section contains the following topics:

Topic	Page
Overview	141
Technical Data	142
Electrical Connections and Dimensions	143
Wiring	146

Overview

General Information

5V Encoder Adapter

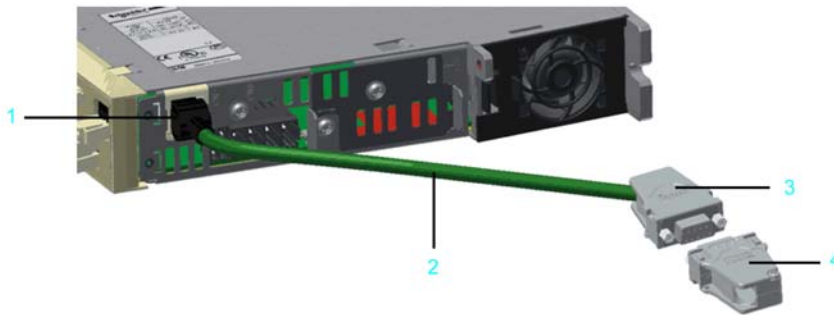

- 1 RJ45 connector
- 2 Encoder cables
- 3 D-Sub 9-pin female connector
- 4 D-Sub 9-pin male connector at the encoder cable (user furnished)

Features

- The 5V Encoder Adapter consists of an encoder cable (2) with an RJ45 connector (1) on one side that is connected to an Lexium 52 drive, as well as a D-Sub 9-pin female connector (3) on the other side.
- A DC/DC converter is assembled in the D-Sub 9-pin female connector (3). It converts the encoder power supply that is coming from the drive from 10 V to 5 V. The 5 V and the 10 V encoder supply voltage is available on the D-Sub 9-pin female connector (3). All the other signals, such as encoder- and RS485 signals are transferred directly from the drive to the encoder.
- This is why it is possible to connect 5 V encoders also, which are not directly supported by the Lexium 52 drive.

NOTICE

CURRENT TOO HIGH AT THE ENCODER CONNECTOR OF THE LEXIUM 52 DRIVE BY USING BOTH 5 V AND 10 V VOLTAGE SUPPLY

- Use exclusively one voltage supply for the encoder, either 5 V or 10 V.
- Only use 5 V encoders with a maximum power consumption of 250 mA.

Failure to follow these instructions can result in equipment damage.

For further information on the 5V Encoder Adapter, see catalog *Motion centric machine automation with PacDrive 3*.

Technical Data

Technical Data

Parameter		Value
Item name		VW3E6027
Output voltage		DC 10 V (-5% / +5%)
Maximum output current		125 mA
Output voltage		DC 5 V (-1% / +1%)
Maximum output current		250 mA
Sin/Cos input voltage		1 V _{pp} / 2.5 V offset 0.5 V _{pp} by 100 kHz
Input resistance		120 Ω
Cutoff-frequency		100 MHz (6000 min ⁻¹ x 1024)
Operation	Protection class housing	IP20 with connected plug-in connectors
	Ambient temperature	+5...+55 °C (+41...+131 °F)
	Relative humidity	5...85%
Transport	Ambient temperature	-25...+70 °C (-13...+158 °F)
	Relative humidity	5...95%
Long-term storage in the transport packaging	Ambient temperature	-25...+55 °C (-13...+131 °F)
	Relative humidity	10...95%

Electrical Connections and Dimensions

RJ45 Connector - 5V Encoder Adapter Input

The RJ45 connector is connected to the connection **CN3** of the drive. Pin assignment of the RJ45 connector is identical to the pin assignment for the connection **CN3** of the drive.

D-Sub 9-Pin Female Connector - 5V Encoder Adapter Output

The D-Sub 9-pin female connector is connected to the D-Sub 9-pin male connector of the encoder cable (user furnished).

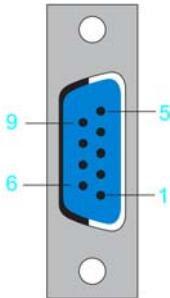

Electrical connection D-Sub 9-pin female connector

Pin	Designation	Description	Range
1	SIN	Positive sine signal	1 V _{pp} ±0.1 V
2	Ref_Sin	Negative sine signal	Offset 2.5 ±0.3 V
3	COS	Positive cosine signal	1 V _{pp} ±0.1 V
4	Ref_Cos	Negative cosine signal	Offset 2.5 ±0.3 V
5	RS485+	Positive RS-485 signal	–
6	P5V	5 V encoder supply voltage	5 V ±1% / I _{out_max} =250 mA
7	P10V	10 V encoder supply voltage	10 V ±5% / I _{out_max} =125 mA
8	RS485-	Negative RS-485 signal	–
9	GND	Encoder return	0 V

D-Sub 9-Pin Male Connector - Encoder Cable Pre-Assembled by the Customer

View mating side



View soldering side

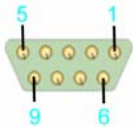

Electrical connection D-Sub 9-pin male connector

Pin	Designation	Description	Range
1	SIN	Positive sine signal	1 V _{pp} ±0.1 V
2	Ref_Sin	Negative sine signal	Offset 2.5 ±0.3 V
3	COS	Positive cosine signal	1 V _{pp} ±0.1 V
4	Ref_Cos	Negative cosine signal	Offset 2.5 ±0.3 V
5	N.C.	Reserved	–
6	P5V	5 V encoder supply voltage	5 V ±1% / I _{out_max} =250 mA
7	P10V	10 V encoder supply voltage	10 V ±5% / I _{out_max} =125 mA
8	N.C.	Reserved	–
9	GND	Encoder return	0 V

Dimensions

Dimensions 5V Encoder Adapter:

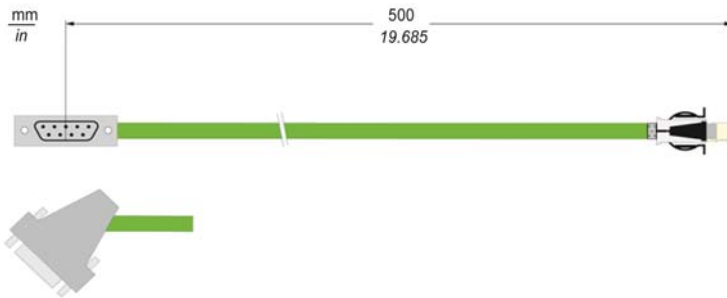

Wiring

Encoder Cable

Connection of D-Sub 9-pin male connectors at the encoder cable (user furnished):

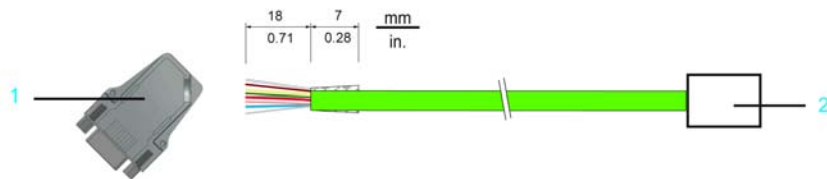

- 1 D-Sub 9-pin male connector at the encoder cable
- 2 Encoder connector

Cable configuration of encoder cable

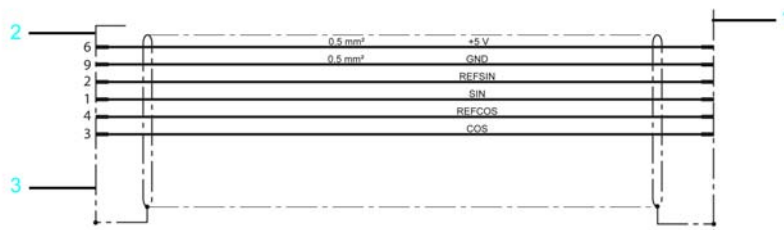

- 1 Encoder connector
- 2 D-Sub 9-pin male connector at the encoder cable
- 3 Metal housing

Maximum encoder cable length

Connection cross section [mm ²] / [AWG]	Current consumption [A]	Maximum encoder cable length [m] / [ft]
0.5 / 20	0.05	58 / 190.3
	0.07	41 / 134.5
	0.10	29 / 95.1
	0.12	24 / 78.7
	0.18	16 / 52.5
	0.24	12 / 39.4

Appendix D

Units and Conversion Tables

Units and Conversion Tables

Length

–	in	ft	yd	m	cm	mm
in	–	/ 12	/ 36	* 0.0254	* 2.54	* 25.4
ft	* 12	–	/ 3	* 0.30479	* 30.479	* 304.79
yd	* 36	* 3	–	* 0.9144	* 91.44	* 914.4
m	/ 0.0254	/ 0.30479	/ 0.9144	–	*100	*1000
cm	/ 2.54	/ 30.479	/ 91.44	/ 100	–	* 10
mm	/ 25.4	/ 304.79	/ 914.4	/ 1000	/ 10	–

Mass

–	lb	oz	slug	0.22 kg	g
lb	–	* 16	* 0.03108095	* 0.4535924	* 453.5924
oz	/ 16	–	* 1.942559*10 ⁻³	* 0.02834952	* 28.34952
slug	/ 0.03108095	/ 1.942559*10 ⁻³	–	* 14.5939	* 14593.9
0.22 kg	/ 0.45359237	/ 0.02834952	/ 14.5939	–	*1000
g	/ 453.59237	/ 28.34952	/ 14593.9	/ 1000	–

Force

–	lb	oz	p	dyne	N
lb	–	* 16	* 453.55358	* 444822.2	* 4.448222
oz	/ 16	–	* 28.349524	* 27801	* 0.27801
p	/ 453.55358	/ 28.349524	–	* 980.7	* 9.807*10 ⁻³
dyne	/ 444822.2	/ 27801	/ 980.7	–	/ 100*10 ³
N	/ 4.448222	/ 0.27801	/ 9.807*10 ⁻³	* 100*10 ³	–

Power

–	HP	W
HP	–	* 746
W	/ 746	–

Rotation

–	min ⁻¹ (rpm)	rad/s	deg./s
min ⁻¹ (rpm)	–	* $\pi / 30$	* 6
rad/s	* $30 / \pi$	–	* 57.295
deg./s	/ 6	/ 57.295	–

Torque

–	lb•in	lb•ft	oz•in	Nm	kp•m	kp•cm	dyne•cm
lb•in	–	/ 12	* 16	* 0.112985	* 0.011521	* 1.1521	* $1.129 \cdot 10^6$
lb•ft	* 12	–	* 192	* 1.355822	* 0.138255	* 13.8255	* $13.558 \cdot 10^6$
oz•in	/ 16	/ 192	–	* $7.0616 \cdot 10^{-3}$	* $720.07 \cdot 10^{-6}$	* $72.007 \cdot 10^{-3}$	* 70615.5
Nm	/ 0.112985	/ 1.355822	/ $7.0616 \cdot 10^{-3}$	–	* 0.101972	* 10.1972	* $10 \cdot 10^6$
kp•m	/ 0.011521	/ 0.138255	/ $720.07 \cdot 10^{-6}$	/ 0.101972	–	* 100	* $98.066 \cdot 10^6$
kp•cm	/ 1.1521	/ 13.8255	/ $72.007 \cdot 10^{-3}$	/ 10.1972	/ 100	–	* $0.9806 \cdot 10^6$
dyne•cm	/ $1.129 \cdot 10^6$	/ $13.558 \cdot 10^6$	/ 70615.5	/ $10 \cdot 10^6$	/ $98.066 \cdot 10^6$	/ $0.9806 \cdot 10^6$	–

Moment of Inertia

–	lb•in ²	lb•ft ²	kg•m ²	kg•cm ²	kg•cm ² •s ²	oz•in ²
lb•in ²	–	/ 144	/ 3417.16	/ 0.341716	/ 335.109	* 16
lb•ft ²	* 144	–	/ 3	* 0.30479	* 30.479	* 304.79
kg•m ²	* 3417.16	/ 0.04214	–	* 0.9144	* 91.44	* 914.4
kg•cm ²	* 0.341716	/ 421.4	/ 0.9144	–	* 100	* 1000
kg•cm ² •s ²	* 335.109	/ 0.429711	/ 91.44	/ 100	–	* 10
oz•in ²	/ 16	/ 2304	/ 54674	/ 5.46	/ 5361.74	–

Temperature

–	°F	max	K
°F	–	$(°F - 32) * 5/9$	$(°F - 32) * 5/9 + 273.15$
max	$°C * 9/5 + 32$	–	$°C + 273.15$
K	$(K - 273.15) * 9/5 + 32$	$K - 273.15$	–

Conductor Cross-section

AWG	1	2	3	4	5	6	7	8	9	10	11	12	13
mm ²	42.4	33.6	26.7	21.2	16.8	13.3	10.5	8.4	6.6	5.3	4.2	3.3	2.6

AWG	14	15	16	17	18	19	20	21	22	23	24	25	26
mm ²	2.1	1.7	1.3	1.0	0.82	0.65	0.52	0.41	0.33	0.26	0.20	0.16	0.13



B

bending cycles, *46*

C

certifications, *125*
climatic, *41*
condensate, *42*
contact addresses, *136*
cooling units, *42*

D

defined safe stop, *65*
degree of protection, *40*
domestic appliances, *19*

E

emergency stop, *64*

F

floating systems, *19*

H

hazard and risk analysis, *62*
hazardous, explosive atmospheres, *19*
homepage, *136*

I

installation, *69*
InverterEnable, *65*
IP, *40*

L

life support system, *19*

M

machine grounding, *45*
mechanical, *41*
minimum bending radius, *46*
minimum cross sections, *45*
mobile systems, *20*

O

opto-coupler, *65*

P

portable systems, *20*
product related information, *14*

Q

qualification of personnel, *21*
qualified person, *21*

S

SCCR, *48*
seminars, *136*
service addresses, *136*
standards, *78*
stop category 0, *65*
stop category 1, *66*

T

temperature limit, *42*
training, *21*
training courses, *136*

U

underground, *19*

W

wiring, *45*