

Modicon Edge I/O NTS

Discrete Modules

User Guide

Original instructions

EIO0000005238.04
02/2026

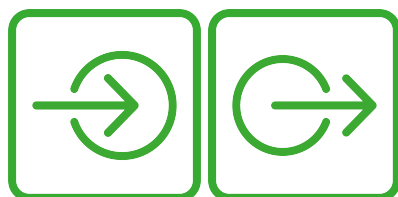

Legal Information

The information provided in this document contains general descriptions, technical characteristics and/or recommendations related to products/solutions.

This document is not intended as a substitute for a detailed study or operational and site-specific development or schematic plan. It is not to be used for determining suitability or reliability of the products/solutions for specific user applications. It is the duty of any such user to perform or have any professional expert of its choice (integrator, specifier or the like) perform the appropriate and comprehensive risk analysis, evaluation and testing of the products/solutions with respect to the relevant specific application or use thereof.

The Schneider Electric brand and any trademarks of Schneider Electric SE and its subsidiaries referred to in this document are the property of Schneider Electric SE or its subsidiaries. All other brands may be trademarks of their respective owner.

This document and its content are protected under applicable copyright laws and provided for informative use only. No part of this document may be reproduced or transmitted in any form or by any means (electronic, mechanical, photocopying, recording, or otherwise), for any purpose, without the prior written permission of Schneider Electric.

Schneider Electric does not grant any right or license for commercial use of the document or its content, except for a non-exclusive and personal license to consult it on an "as is" basis.

Schneider Electric reserves the right to make changes or updates with respect to or in the content of this document or the format thereof, at any time without notice.

To the extent permitted by applicable law, no responsibility or liability is assumed by Schneider Electric and its subsidiaries for any errors or omissions in the informational content of this document, as well as any non-intended use or misuse of the content thereof.

Table of Contents

Safety Information	12
Before You Begin	12
Start-up and Test	13
Operation and Adjustments	14
About the Document	15
General Overview	20
Discrete Input Modules	22
NTSDDI0402/NTSDDI0402H Discrete Input Module, 4 Inputs, 24 Vdc, Sink, Diagnostics, 1-/2-/3-wire, Standard/Hardened	23
NTSDDI0402/NTSDDI0402H Presentation	23
Main Characteristics	23
Purchasing Information	24
Physical Description	25
Status LEDs	26
NTSDDI0402/NTSDDI0402H Characteristics	26
Overview	26
Dimensions	27
Weight	27
General Characteristics	28
Input Characteristics	30
NTSDDI0402/NTSDDI0402H Wiring	30
Wiring Rules	30
Wiring Diagrams	31
NTSDDI0402/NTSDDI0402H Parameters	33
Parameters Description	33
NTSDDI0602 Discrete Input Module, 6 Inputs, 24 Vdc, Sink, 1-/2-/3- wire	37
NTSDDI0602 Presentation	37
Main Characteristics	37
Purchasing Information	38
Physical Description	39
Status LEDs	40
NTSDDI0602 Characteristics	41
Overview	41
Dimensions	41
Weight	42
General Characteristics	42
Input Characteristics	43
NTSDDI0602 Wiring	44
Wiring Rules	44
Wiring Diagram	44
NTSDDI0602 Parameters	45
Parameters Description	45
NTSDDI0802X Discrete Input Module, 8 Inputs, 24 Vdc, Sink, 1-/2- wire	48
NTSDDI0802X Presentation	48
Main Characteristics	48
Purchasing Information	49

Physical Description	50
Status LEDs	51
NTSDDI0802X Characteristics	52
Overview	52
Dimensions	52
Weight.....	53
General Characteristics	53
Input Characteristics.....	54
NTSDDI0802X Wiring	55
Wiring Rules	55
Wiring Diagrams	55
NTSDDI0802X Parameters	58
Parameters Description	58
NTSDDI1602 Discrete Input Module, 16 Inputs, 24 Vdc, Sink, 1-wire	61
NTSDDI1602 Presentation	61
Main Characteristics	61
Purchasing Information.....	62
Physical Description	63
Status LEDs	64
NTSDDI1602 Characteristics	65
Overview	65
Dimensions	65
Weight.....	66
General Characteristics	66
Input Characteristics.....	67
NTSDDI1602 Wiring	68
Wiring Rules	68
Wiring Diagrams	68
NTSDDI1602 Parameters.....	70
Parameters Description	70
NTSDDI1602X/NTSDDI1602XH Discrete Input Module, 16 Inputs, 24 Vdc, Sink, 1-/2-/3-wire, Standard/Hardened	73
NTSDDI1602X/NTSDDI1602XH Presentation.....	73
Main Characteristics	73
Purchasing Information.....	74
Physical Description	75
Status LEDs	76
NTSDDI1602X/NTSDDI1602XH Characteristics	77
Overview	77
Dimensions	77
Weight.....	78
General Characteristics	78
Input Characteristics.....	79
NTSDDI1602X/NTSDDI1602XH Wiring	80
Wiring Rules	80
Wiring Diagrams	80
NTSDDI1602X/NTSDDI1602XH Parameters	83
Parameters Description	83
NTSDDI1642 Discrete Input Module, 16 Inputs, 24 Vdc, Source, 1-wire	86
NTSDDI1642 Presentation	86

Main Characteristics	86
Purchasing Information	87
Physical Description	88
Status LEDs	89
NTSDDI1642 Characteristics	90
Overview	90
Dimensions	90
Weight.....	91
General Characteristics	91
Input Characteristics.....	92
NTSDDI1642 Wiring	93
Wiring Rules	93
Wiring Diagrams	93
NTSDDI1642 Parameters.....	95
Parameters Description	95
NTSDAI0215H Discrete Input Module, 2 Isolated Inputs, 100...240 Vac, 1-/2-/3-wire, Hardened	98
NTSDAI0215H Presentation	98
Main Characteristics	98
Purchasing Information.....	99
Physical Description	100
Status LEDs	101
NTSDAI0215H Characteristics.....	102
Overview	102
Dimensions	102
Weight.....	103
General Characteristics	103
Input Characteristics.....	104
NTSDAI0215H Wiring	105
Wiring Rules	105
Wiring Diagrams	105
NTSDAI0215H Parameters	108
Parameters Description	108
NTSDAI0403H Discrete Input Module, 4 Inputs, 24 Vac, 48 Vac/Vdc, Sink, 1-/2-/3-wire, Hardened	110
NTSDAI0403H Presentation	110
Main Characteristics	110
Purchasing Information.....	111
Physical Description	112
Status LEDs	113
NTSDAI0403H Characteristics.....	114
Overview	114
Dimensions	114
Weight.....	115
General Characteristics	115
Input Characteristics.....	116
NTSDAI0403H Wiring Diagram.....	117
Wiring Rules	117
Wiring Diagrams	117
NTSDAI0403H Parameters	119
Parameters Description	119

NTSDAI0404H Discrete Input Module, 4 Inputs, 100...120 Vac, 1-/2-wire, Hardened.....	123
NTSDAI0404H Presentation	123
Main Characteristics	123
Purchasing Information.....	124
Physical Description	125
Status LEDs	126
NTSDAI0404H Characteristics.....	127
Overview	127
Dimensions	127
Weight.....	128
General Characteristics	128
Input Characteristics.....	129
NTSDAI0404H Wiring	130
Wiring Rules	130
Wiring Diagram	130
NTSDAI0404H Parameters	131
Parameters Description	131
NTSDAI0804 Discrete Input Module, 8 Inputs, 100...120 Vac, 1-wire	133
NTSDAI0804 Presentation	133
Main Characteristics.....	133
Purchasing Information.....	134
Physical Description	135
Status LEDs	136
NTSDAI0804 Characteristics	137
Overview	137
Dimensions	137
Weight.....	138
General Characteristics	138
Input Characteristics.....	139
NTSDAI0804 Wiring.....	140
Wiring Rules	140
Wiring Diagram	140
NTSDAI0804 Parameters	141
Parameters Description	141
Discrete Output Modules	143
NTSDDO0212H Discrete Output Module, 2 Isolated Outputs, 24 Vdc, 2 A, Source, Protected, 1-/2-/3-wire, Hardened.....	144
NTSDDO0212H Presentation	144
Main Characteristics.....	144
Purchasing Information.....	145
Physical Description	146
Status LEDs	147
NTSDDO0212H Characteristics.....	148
Overview	148
Dimensions	148
Weight.....	149
General Characteristics	149
Output Characteristics	150
NTSDDO0212H Wiring	151

Wiring Rules	151
Wiring Diagrams	151
NTSDDO0212H Parameters	153
Parameters Description	153
NTSDDO0402/NTSDDO0402H Discrete Output Module, 4 Outputs, 24 Vdc, 500 mA, Source, Diagnostics, Protected, 1-/2-/3-wire, Standard/Hardened	156
NTSDDO0402/NTSDDO0402H Presentation	156
Main Characteristics	156
Purchasing Information	157
Physical Description	158
Status LEDs	159
NTSDDO0402/NTSDDO0402H Characteristics	160
Overview	160
Dimensions	160
Weight	161
General Characteristics	161
Output Characteristics	162
NTSDDO0402/NTSDDO0402H Wiring	163
Wiring Rules	163
Wiring Diagram	163
NTSDDO0402/NTSDDO0402H Parameters	164
Parameters Description	164
NTSDDO0602 Discrete Output Module, 6 Outputs, 24 Vdc, 500 mA, Source, Protected, 1-/2-/3-wire	167
NTSDDO0602 Presentation	167
Main Characteristics	167
Purchasing Information	168
Physical Description	169
Status LEDs	170
NTSDDO0602 Characteristics	171
Overview	171
Dimensions	171
Weight	172
General Characteristics	172
Output Characteristics	173
NTSDDO0602 Wiring	174
Wiring Rules	174
Wiring Diagram	174
NTSDDO0602 Parameters	175
Parameters Description	175
NTSDDO0802 Discrete Output Module, 8 Outputs, 24 Vdc, 2 A, Source, Protected, External Supply, 1-wire	177
NTSDDO0802 Presentation	177
Main Characteristics	177
Purchasing Information	178
Physical Description	179
Status LEDs	180
NTSDDO0802 Characteristics	181
Overview	181
Dimensions	181

Weight.....	182
General Characteristics	182
Output Characteristics	183
NTSDDO0802 Wiring.....	184
Wiring Rules	184
Wiring Diagram	184
NTSDDO0802 Parameters	185
Parameters Description	185
NTSDDO0802X Discrete Output Module, 8 Outputs, 24 Vdc, 500 mA, Source, Protected, 1-1/2-wire	187
NTSDDO0802X Presentation	187
Main Characteristics	187
Purchasing Information.....	188
Physical Description	189
Status LEDs	190
NTSDDO0802X Characteristics	191
Overview	191
Dimensions	191
Weight.....	192
General Characteristics	192
Output Characteristics	193
NTSDDO0802X Wiring.....	194
Wiring Rules	194
Wiring Diagram	194
NTSDDO0802X Parameters	195
Parameters Description	195
NTSDDO1602 Discrete Output Module, 16 Outputs, 24 Vdc, 500 mA, Source, Protected, 1-wire	197
NTSDDO1602 Presentation.....	197
Main Characteristics	197
Purchasing Information.....	198
Physical Description	199
Status LEDs	200
NTSDDO1602 Characteristics	201
Overview	201
Dimensions	201
Weight.....	202
General Characteristics	202
Output Characteristics	203
NTSDDO1602 Wiring.....	204
Wiring Rules	204
Wiring Diagrams	204
NTSDDO1602 Parameters	206
Parameters Description	206
NTSDDO1602X/NTSDDO1602XH Discrete Output Module, 16 Outputs, 24 Vdc, 500 mA, Source, Protected, 1-1/2-wire, Standard/Hardened	209
NTSDDO1602X/NTSDDO1602XH Presentation	209
Main Characteristics	209
Purchasing Information.....	210
Physical Description	211
Status LEDs	212

NTSDDO1602X/NTSDDO1602XH Characteristics	213
Overview	213
Dimensions	213
Weight.....	214
General Characteristics	214
Output Characteristics	215
NTSDDO1602X/NTSDDO1602XH Wiring.....	216
Wiring Rules	216
Wiring Diagram	216
NTSDDO1602X/NTSDDO1602XH Parameters.....	217
Parameters Description	217
NTSDDO1602XA/NTSDDO1602XAH Discrete Output Module, 16 Outputs, 24 Vdc, 500 mA, Source, Protected, External Supply, 1-/2-wire, Standard/Hardened	220
NTSDDO1602XA/NTSDDO1602XAH Presentation	220
Main Characteristics.....	220
Purchasing Information.....	221
Physical Description	222
Status LEDs	223
NTSDDO1602XA/NTSDDO1602XAH Characteristics.....	224
Overview	224
Dimensions	224
Weight.....	225
General Characteristics	225
Output Characteristics	226
NTSDDO1602XA/NTSDDO1602XAH Wiring	227
Wiring Rules	227
Wiring Diagram	227
NTSDDO1602XA/NTSDDO1602XAH Parameters	228
Parameters Description	228
NTSDAO0205 Discrete Output Module, 2 Outputs, 1 A, 100...240 Vac, 1-/ 2-/3-wire	231
NTSDAO0205 Presentation.....	231
Main Characteristics.....	231
Purchasing Information.....	232
Physical Description	233
Status LEDs	234
NTSDAO0205 Characteristics	235
Overview	235
Dimensions	235
Weight.....	236
General Characteristics	236
Output Characteristics	237
NTSDAO0205 Wiring.....	238
Wiring Rules	238
Wiring Diagram	238
NTSDAO0205 Parameters	239
Parameters Description	239
NTSDAO0415/NTSDAO0415H Discrete Output Module, 4 Isolated Outputs, 2 A, 100...240 Vac, 1-/2-/3-wire, Standard/Hardened	241
NTSDAO0415/NTSDAO0415H Presentation	241

Main Characteristics	241
Purchasing Information	242
Physical Description	243
Status LEDs	244
NTSDAO0415/NTSDAO0415H Characteristics	245
Overview	245
Dimensions	245
Weight.....	246
General Characteristics	246
Output Characteristics	247
NTSDAO0415/NTSDAO0415H Wiring	247
Wiring Rules	247
Wiring Diagrams	247
NTSDAO0415/NTSDAO0415H Parameters.....	249
Parameters Description	249
NTSDRC0215 Relay Output Module, 2 Isolated Outputs, NO/NC, 2 A, 5...125 Vdc, 24...240 Vac	251
NTSDRC0215 Presentation.....	251
Main Characteristics	251
Purchasing Information.....	252
Physical Description	253
Status LEDs	254
NTSDRC0215 Characteristics	255
Overview	255
Dimensions	255
Weight.....	256
General Characteristics	256
Output Characteristics	257
NTSDRC0215 Wiring	258
Wiring Rules	258
Wiring Diagrams	258
NTSDRC0215 Parameters	261
Parameters Description	261
NTSDRC0415/NTSDRC0415H Relay Output Module, 4 Isolated Outputs, NO/NC, 5 A, 5...125 Vdc, 24...240 Vac, Standard/Hardened	263
NTSDRC0415/NTSDRC0415H Presentation	263
Main Characteristics	263
Purchasing Information.....	264
Physical Description	265
Status LEDs	266
NTSDRC0415/NTSDRC0415H Characteristics.....	267
Overview	267
Dimensions	267
Weight.....	268
General Characteristics	268
Output Characteristics	269
NTSDRC0415/NTSDRC0415H Wiring Diagram	270
Wiring Rules	270
Wiring Diagram	270
NTSDRC0415/NTSDRC0415H Parameters.....	272
Parameters Description	272

NTSDRA0615 Relay Output Module, 6 Isolated Outputs, NO, 2 A, 5...125 Vdc, 24...240 Vac	274
NTSDRA0615 Presentation	274
Main Characteristics	274
Purchasing Information	275
Physical Description	276
Status LEDs	277
NTSDRA0615 Characteristics	278
Overview	278
Dimensions	278
Weight	279
General Characteristics	279
Output Characteristics	280
NTSDRA0615 Wiring	281
Wiring Rules	281
Wiring Diagrams	281
NTSDRA0615 Parameters	283
Parameters Description	283
Appendices	285
Input Latch	286
Short Circuit Diagnostic and Recovery Methodology	289
Auto Recovery Mode	289
Latched Off Mode	292
Glossary	297
Index	299

Safety Information

Important Information

Read these instructions carefully, and look at the equipment to become familiar with the device before trying to install, operate, service, or maintain it. The following special messages may appear throughout this documentation or on the equipment to warn of potential hazards or to call attention to information that clarifies or simplifies a procedure.



The addition of this symbol to a “Danger” or “Warning” safety label indicates that an electrical hazard exists which will result in personal injury if the instructions are not followed.



This is the safety alert symbol. It is used to alert you to potential personal injury hazards. Obey all safety messages that follow this symbol to avoid possible injury or death.

DANGER

DANGER indicates a hazardous situation which, if not avoided, **will result in** death or serious injury.

WARNING

WARNING indicates a hazardous situation which, if not avoided, **could result in** death or serious injury.

CAUTION

CAUTION indicates a hazardous situation which, if not avoided, **could result in** minor or moderate injury.

NOTICE

NOTICE is used to address practices not related to physical injury.

Please Note

Electrical equipment should be installed, operated, serviced, and maintained only by qualified personnel. No responsibility is assumed by Schneider Electric for any consequences arising out of the use of this material.

A qualified person is one who has skills and knowledge related to the construction and operation of electrical equipment and its installation, and has received safety training to recognize and avoid the hazards involved.

Before You Begin

Do not use this product on machinery lacking effective point-of-operation guarding. Lack of effective point-of-operation guarding on a machine can result in serious injury to the operator of that machine.

▲ WARNING**UNGUARDED EQUIPMENT**

- Do not use this software and related automation equipment on equipment which does not have point-of-operation protection.
- Do not reach into machinery during operation.

Failure to follow these instructions can result in death, serious injury, or equipment damage.

This automation equipment and related software is used to control a variety of industrial processes. The type or model of automation equipment suitable for each application will vary depending on factors such as the control function required, degree of protection required, production methods, unusual conditions, government regulations, etc. In some applications, more than one processor may be required, as when backup redundancy is needed.

Only you, the user, machine builder or system integrator can be aware of all the conditions and factors present during setup, operation, and maintenance of the machine and, therefore, can determine the automation equipment and the related safeties and interlocks which can be properly used. When selecting automation and control equipment and related software for a particular application, you should refer to the applicable local and national standards and regulations. The National Safety Council's Accident Prevention Manual (nationally recognized in the United States of America) also provides much useful information.

In some applications, such as packaging machinery, additional operator protection such as point-of-operation guarding must be provided. This is necessary if the operator's hands and other parts of the body are free to enter the pinch points or other hazardous areas and serious injury can occur. Software products alone cannot protect an operator from injury. For this reason the software cannot be substituted for or take the place of point-of-operation protection.

Ensure that appropriate safeties and mechanical/electrical interlocks related to point-of-operation protection have been installed and are operational before placing the equipment into service. All interlocks and safeties related to point-of-operation protection must be coordinated with the related automation equipment and software programming.

NOTE: Coordination of safeties and mechanical/electrical interlocks for point-of-operation protection is outside the scope of the Function Block Library, System User Guide, or other implementation referenced in this documentation.

Start-up and Test

Before using electrical control and automation equipment for regular operation after installation, the system should be given a start-up test by qualified personnel to verify correct operation of the equipment. It is important that arrangements for such a check are made and that enough time is allowed to perform complete and satisfactory testing.

▲ WARNING**EQUIPMENT OPERATION HAZARD**

- Verify that all installation and set up procedures have been completed.
- Before operational tests are performed, remove all blocks or other temporary holding means used for shipment from all component devices.
- Remove tools, meters, and debris from equipment.

Failure to follow these instructions can result in death, serious injury, or equipment damage.

Follow all start-up tests recommended in the equipment documentation. Store all equipment documentation for future references.

Software testing must be done in both simulated and real environments.

Verify that the completed system is free from all short circuits and temporary grounds that are not installed according to local regulations (according to the National Electrical Code in the U.S.A, for instance). If high-potential voltage testing is necessary, follow recommendations in equipment documentation to prevent accidental equipment damage.

Before energizing equipment:

- Remove tools, meters, and debris from equipment.
- Close the equipment enclosure door.
- Remove all temporary grounds from incoming power lines.
- Perform all start-up tests recommended by the manufacturer.

Operation and Adjustments

The following precautions are from the NEMA Standards Publication ICS 7.1-1995:

(In case of divergence or contradiction between any translation and the English original, the original text in the English language will prevail.)

- Regardless of the care exercised in the design and manufacture of equipment or in the selection and ratings of components, there are hazards that can be encountered if such equipment is improperly operated.
- It is sometimes possible to misadjust the equipment and thus produce unsatisfactory or unsafe operation. Always use the manufacturer's instructions as a guide for functional adjustments. Personnel who have access to these adjustments should be familiar with the equipment manufacturer's instructions and the machinery used with the electrical equipment.
- Only those operational adjustments required by the operator should be accessible to the operator. Access to other controls should be restricted to prevent unauthorized changes in operating characteristics.

About the Document

Document Scope

This guide describes the implementation of Modicon Edge I/O NTS discrete modules. It provides the description, characteristics, wiring diagrams and configuration details for Modicon Edge I/O NTS discrete modules.

Validity Note

This document has been updated for the release of Modicon Edge I/O NTS discrete modules firmware versions available at the publication date of this document.

The characteristics of the products described in this document are intended to match the characteristics that are available on www.se.com. As part of our corporate strategy for constant improvement, we may revise the content over time to enhance clarity and accuracy. If you see a difference between the characteristics in this document and the characteristics on www.se.com, consider www.se.com to contain the latest information.

Product Related Information

DANGER

HAZARD OF ELECTRIC SHOCK, EXPLOSION OR ARC FLASH

- Disconnect all power from all equipment including connected devices prior to removing any covers or doors, or installing or removing any accessories, hardware, cables, or wires except under the specific conditions specified in the appropriate hardware guide for this equipment.
- Always use a properly rated voltage sensing device to confirm the power is off where and when indicated.
- Replace and secure all covers, accessories, hardware, cables, and wires and confirm that a proper ground connection exists before applying power to the equipment.
- Use only the specified voltage when operating this equipment and any associated products.

Failure to follow these instructions will result in death or serious injury.

▲ WARNING**LOSS OF CONTROL**

- Perform a Failure Mode and Effects Analysis (FMEA), or equivalent risk analysis, of your application, and apply preventive and detective controls before implementation.
- Provide a fallback state for undesired control events or sequences.
- Provide separate or redundant control paths wherever required.
- Supply appropriate parameters, particularly for limits.
- Review the implications of transmission delays and take actions to mitigate them.
- Review the implications of communication link interruptions and take actions to mitigate them.
- Provide independent paths for control functions (for example, emergency stop, over-limit conditions, and error conditions) according to your risk assessment, and applicable codes and regulations.
- Apply local accident prevention and safety regulations and guidelines.¹
- Test each implementation of a system for proper operation before placing it into service.

Failure to follow these instructions can result in death, serious injury, or equipment damage.

¹ For additional information, refer to NEMA ICS 1.1 (latest edition), *Safety Guidelines for the Application, Installation, and Maintenance of Solid State Control* and to NEMA ICS 7.1 (latest edition), *Safety Standards for Construction and Guide for Selection, Installation and Operation of Adjustable-Speed Drive Systems* or their equivalent governing your particular location.

▲ WARNING**UNINTENDED EQUIPMENT OPERATION**

- Only use software approved by Schneider Electric for use with this equipment.
- Update your application program every time you change the physical hardware configuration.

Failure to follow these instructions can result in death, serious injury, or equipment damage.

General Cybersecurity Information

In recent years, the growing number of networked machines and production plants has seen a corresponding increase in the potential for cyber threats, such as unauthorized access, data breaches, and operational disruptions. You must, therefore, consider all possible cybersecurity measures to help protect assets and systems against such threats.

To help keep your Schneider Electric products secure and protected, it is in your best interest to implement the cybersecurity best practices as described in the [Cybersecurity Best Practices](#) document.

Schneider Electric provides additional information and assistance:

- [Subscribe to the Schneider Electric security newsletter.](#)
- [Visit the Cybersecurity Support Portal web page to:](#)
 - [Find Security Notifications.](#)
 - [Report vulnerabilities and incidents.](#)
- [Visit the Schneider Electric Cybersecurity and Data Protection Posture web page to:](#)
 - [Access the cybersecurity posture.](#)
 - [Learn more about cybersecurity in the cybersecurity academy.](#)
 - [Explore the cybersecurity services from Schneider Electric.](#)

Environmental Data

For product compliance and environmental information, refer to the [Schneider Electric Environmental Data Program](#).

Available Languages of the Document

The document is available in these languages:

- [English \(EIO0000005238\)](#)
- [French \(EIO0000005239\)](#)
- [Chinese \(EIO0000005243\)](#)

Related Documents

Title of documentation	Reference number
Modicon Edge I/O - System Planning and Installation Guide	EIO0000004786 (ENG)
	EIO0000004787 (FRE)
	EIO0000004791 (CHS)
Modicon Edge I/O - Configurator and Web Interface - User Guide	EIO0000004810 (ENG)
	EIO0000004811 (FRE)
	EIO0000004815 (CHS)
Modicon Edge I/O - Software Integration and Compatibility - User Guide	EIO0000004818 (ENG)
	EIO0000004819 (FRE)
	EIO0000004823 (CHS)
Modicon Edge I/O - Diagnostic Data - User Guide	EIO0000004826 (ENG)
	EIO0000004827 (FRE)
	EIO0000004831 (CHS)
Modicon Edge I/O NTS - Network Interface Modules - User Guide	EIO0000004794 (ENG)
	EIO0000004795 (FRE)
	EIO0000004799 (CHS)
Modicon Edge I/O NTS - Analog Modules - User Guide	EIO0000005246 (ENG)
	EIO0000005247 (FRE)
	EIO0000005251 (CHS)
Modicon Edge I/O NTS - Motion Expert Modules - User Guide	EIO0000005254 (ENG)
	EIO0000005255 (FRE)
	EIO0000005259 (CHS)
Modicon Edge I/O NTS - Counting Modules - User Guide	EIO0000005262 (ENG)
	EIO0000005263 (FRE)
	EIO0000005267 (CHS)
Modicon Edge I/O NTS - Field Device Master Modules - User Guide	EIO0000005270 (ENG)
	EIO0000005271 (FRE)
	EIO0000005275 (CHS)

To find documents online, visit the Schneider Electric download center (www.se.com/ww/en/download/).

Information on Non-Inclusive or Insensitive Terminology

As a responsible, inclusive company, Schneider Electric is constantly updating its communications and products that contain non-inclusive or insensitive terminology. However, despite these efforts, our content may still contain terms that are deemed inappropriate by some customers.

Terminology Derived from Standards

The technical terms, terminology, symbols and the corresponding descriptions in the information contained herein, or that appear in or on the products themselves, are generally derived from the terms or definitions of international standards.

In the area of functional safety systems, drives and general automation, this may include, but is not limited to, terms such as *safety*, *safety function*, *safe state*, *fault*, *fault reset*, *malfunction*, *failure*, *error*, *error message*, *dangerous*, etc.

Among others, these standards include:

Standard	Description
IEC 61131-2:2007	Programmable controllers, part 2: Equipment requirements and tests.
ISO 13849-1:2023	Safety of machinery: Safety related parts of control systems. General principles for design.
EN 61496-1:2020	Safety of machinery: Electro-sensitive protective equipment. Part 1: General requirements and tests.
ISO 12100:2010	Safety of machinery - General principles for design - Risk assessment and risk reduction
EN 60204-1:2006	Safety of machinery - Electrical equipment of machines - Part 1: General requirements
ISO 14119:2013	Safety of machinery - Interlocking devices associated with guards - Principles for design and selection
ISO 13850:2015	Safety of machinery - Emergency stop - Principles for design
IEC 62061:2021	Safety of machinery - Functional safety of safety-related electrical, electronic, and electronic programmable control systems
IEC 61508-1:2010	Functional safety of electrical/electronic/programmable electronic safety-related systems: General requirements.
IEC 61508-2:2010	Functional safety of electrical/electronic/programmable electronic safety-related systems: Requirements for electrical/electronic/programmable electronic safety-related systems.
IEC 61508-3:2010	Functional safety of electrical/electronic/programmable electronic safety-related systems: Software requirements.
IEC 61784-3:2021	Industrial communication networks - Profiles - Part 3: Functional safety fieldbuses - General rules and profile definitions.
2006/42/EC	Machinery Directive
2014/30/EU	Electromagnetic Compatibility Directive
2014/35/EU	Low Voltage Directive

In addition, terms used in the present document may tangentially be used as they are derived from other standards such as:

Standard	Description
IEC 60034 series	Rotating electrical machines
IEC 61800 series	Adjustable speed electrical power drive systems
IEC 61158 series	Digital data communications for measurement and control – Fieldbus for use in industrial control systems

Finally, the term *zone of operation* may be used in conjunction with the description of specific hazards, and is defined as it is for a *hazard zone* or *danger zone* in the *Machinery Directive (2006/42/EC)* and *ISO 12100:2010*.

NOTE: The aforementioned standards may or may not apply to the specific products cited in the present documentation. For more information concerning the individual standards applicable to the products described herein, see the characteristics tables for those product references.

General Overview

The range of Modicon Edge I/O NTS discrete modules includes:

- Discrete Input Modules, page 20
- Discrete Output Modules, page 21

NOTE: References with an H are hardened devices, suitable for harsh environments.

NOTE: The terminal blocks are purchased separately. The compatible terminal block references is printed on the front of the module.

Discrete Input Modules

The following table shows the digital input modules, with the corresponding description and terminal type:

Reference	Number of Channels	Channel Type	Voltage	Terminal Type / Pitch
NTSDDI0402, page 23 / NTSDDI0402H, page 23	4	Sink inputs with diagnostics	24 Vdc	Removable screw/spring terminal block / 5 mm
NTSDDI0602, page 37	6	Sink inputs	24 Vdc	Removable screw/spring terminal block / 3.81 mm
NTSDDI0802X, page 48	8	Sink inputs	24 Vdc	Removable screw/spring terminal block / 5 mm
NTSDDI1602, page 61	16	Sink inputs	24 Vdc	Removable screw/spring terminal block / 3.81 mm
NTSDDI1602X, page 73 / NTSDDI1602XH, page 73	16	Sink inputs	24 Vdc	Removable screw/spring terminal block / 5 mm
NTSDDI1642, page 86	16	Source inputs	24 Vdc	Removable screw/spring terminal block / 3.81 mm
NTSDAI0215H, page 98	2	Isolated inputs	100...240 Vac	Removable screw/spring terminal block / 5 mm
NTSDAI0403H, page 110	4	Inputs (AC) Sink inputs (DC)	24...48 Vac 48 Vdc	Removable screw/spring terminal block / 5 mm
NTSDAI0404H, page 123	4	Inputs	100...120 Vac	Removable screw/spring terminal block / 5 mm
NTSDAI0804, page 133	8	Inputs	100...120 Vac	Removable screw/spring terminal block / 5 mm

Discrete Output Modules

The following table shows the digital output modules, with the corresponding description and terminal type:

Reference	Number of Channels	Channel Type	Voltage Current	Terminal Type / Pitch
NTSDDO0212H, page 144	2	Isolated source outputs	24 Vdc 2 A / channel	Removable screw/spring terminal block / 5 mm
NTSDDO0402, page 156 / NTSDDO0402H, page 156	4	Source outputs with diagnostics	24 Vdc 500 mA / channel	Removable screw/spring terminal block / 5 mm
NTSDDO0602, page 167	6	Source outputs	24 Vdc 500 mA / channel	Removable screw/spring terminal block / 3.81 mm
NTSDDO0802, page 177	8	Source outputs	24 Vdc, external supply 2 A / channel, 8 A / module	Removable screw/spring terminal block / 5 mm
NTSDDO0802X, page 187	8	Source outputs	24 Vdc 500 mA / channel	Removable screw/spring terminal block / 5 mm
NTSDDO1602, page 197	16	Source outputs	24 Vdc 500 mA / channel	Removable screw/spring terminal block / 3.81 mm
NTSDDO1602X, page 209 / NTSDDO1602XH, page 209	16	Source outputs	24 Vdc 500 mA / channel, 4 A / module	Removable screw/spring terminal block / 5 mm
NTSDDO1602XA, page 220 / NTSDDO1602XAH, page 220	16	Source outputs	24 Vdc, external supply 500 mA / channel, 8A / module	Removable screw/spring terminal block / 5 mm
NTSDAO0205, page 231	2	Triac outputs	100...240 Vac 1 A / channel; 2 A / module with derating	Removable screw/spring terminal block / 5 mm
NTSDAO0415, page 241 / NTSDAO0415H, page 241	4	Isolated triac outputs	100...240 Vac 2 A / channel, 8 A / module with derating	Removable screw/spring terminal block / 5 mm
NTSDRC0215, page 251	2	Isolated changeover relay outputs	5...125 Vdc 24...250 Vac 2 A / channel	Removable screw/spring terminal block / 5 mm
NTSDRC0415, page 263 / NTSDRC0415H, page 263	4	Isolated changeover relay outputs	5...125 Vdc 24...250 Vac 5 A / channel, 20 A / module with derating	Removable screw/spring terminal block / 5 mm
NTSDRA0615, page 274	6	Isolated normally open relay outputs	5...125 Vdc 24...250 Vac 2 A / channel	Removable screw/spring terminal block / 5 mm

Discrete Input Modules

What's in This Part

NTSDDI0402/NTSDDI0402H Discrete Input Module, 4 Inputs, 24 Vdc, Sink, Diagnostics, 1-/2-/3-wire, Standard/Hardened	23
NTSDDI0602 Discrete Input Module, 6 Inputs, 24 Vdc, Sink, 1-/2-/3-wire.....	37
NTSDDI0802X Discrete Input Module, 8 Inputs, 24 Vdc, Sink, 1-/2-wire	48
NTSDDI1602 Discrete Input Module, 16 Inputs, 24 Vdc, Sink, 1-wire.....	61
NTSDDI1602X/NTSDDI1602XH Discrete Input Module, 16 Inputs, 24 Vdc, Sink, 1-/2-/3-wire, Standard/Hardened	73
NTSDDI1642 Discrete Input Module, 16 Inputs, 24 Vdc, Source, 1-wire	86
NTSDAI0215H Discrete Input Module, 2 Isolated Inputs, 100...240 Vac, 1-/2-/3-wire, Hardened	98
NTSDAI0403H Discrete Input Module, 4 Inputs, 24 Vac, 48 Vac/Vdc, Sink, 1-/2-/3-wire, Hardened.....	110
NTSDAI0404H Discrete Input Module, 4 Inputs, 100...120 Vac, 1-/2-wire, Hardened	123
NTSDAI0804 Discrete Input Module, 8 Inputs, 100...120 Vac, 1-wire	133

NTSDDI0402/NTSDDI0402H Discrete Input Module, 4 Inputs, 24 Vdc, Sink, Diagnostics, 1-/2-/3-wire, Standard/Hardened

What's in This Chapter

NTSDDI0402/NTSDDI0402H Presentation 23
 NTSDDI0402/NTSDDI0402H Characteristics 26
 NTSDDI0402/NTSDDI0402H Wiring 30
 NTSDDI0402/NTSDDI0402H Parameters 33

NTSDDI0402/NTSDDI0402H Presentation

Main Characteristics

The following table describes the main characteristics of the NTSDDI0402/NTSDDI0402H input modules:

Main Characteristics	Value
Product or component type	Discrete DC input module with diagnostics
Number of Input channels	4
Groups of channels	1 group of 4 channels
Nominal input voltage	12 Vdc / 24 Vdc
Input logic type	Sink
Operating mode	Synchronous and isochronous

Purchasing Information

The following figure shows the elements of the Modicon Edge I/O NTS
NTSDDI0402/NTSDDI0402H input modules:

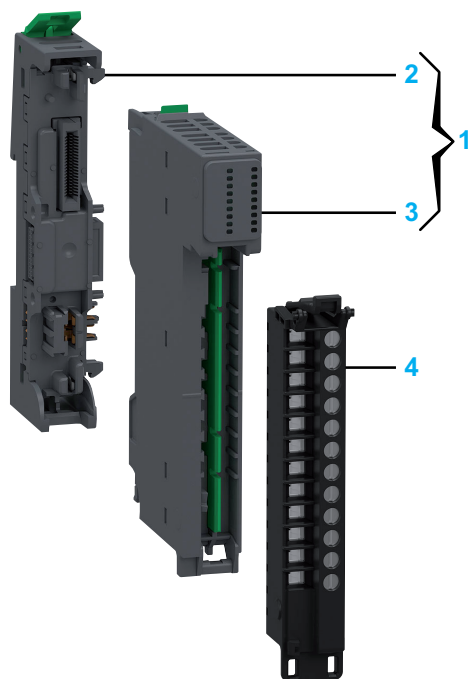

Number	Reference	Description
1	NTSDDI0402K NTSDDI0402HK	Base + Module (kit) NOTE: The module and its corresponding base can be purchased as a kit.
2	NTSXBA0100H	Spare Base, 1 Slot, for Input/Output Common or Expert Module, Hardened
3	NTSDDI0402 NTSDDI0402H	Discrete Input Module, 4 Inputs, 24 Vdc, Sink, Diagnostics, 1-/2-/3-wire Discrete Input Module, 4 Inputs, 24 Vdc, Sink, Diagnostics, 1-/2-/3-wire, Hardened
4	NTSXTB12200H NTSXTB12201H NTSXTB12000H NTSXTB12001H	Spring Terminal Block, 12 Points, 5 mm Pitch, Without Cover, use on Low Height Module, Hardened Spring Terminal Block, 12 Points, 5 mm Pitch, With Cover, use on Low Height Module, Hardened Screw Terminal Block, 12 Points, 5 mm Pitch, Without Cover, use on Low Height Module, Hardened Screw Terminal Block, 12 Points, 5 mm Pitch, With cover, use on Low Height Module, Hardened NOTE: The terminal blocks are purchased separately.

NOTE: For more information on accessories and spare parts, refer to Modicon Edge I/O - System Planning and Installation Guide.

Physical Description

The following figure presents the elements of the module:

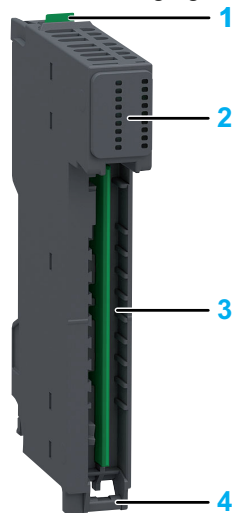

- 1: Release button for disengaging the module from the base
- 2: Status LEDs
- 3: Slot for the terminal block
- 4: Hinge for the terminal block installation

Status LEDs

The following figure presents the NTSDDI0402/NTSDDI0402H status LEDs:

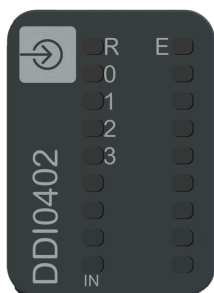

The following table describes the status of LEDs:

R (Green)	E (Red)	IN0...3 (Green)	Description
Initialization and non-operational states			
OFF	OFF	OFF	Indicates that the module is not energized.
OFF	Fast Flash	-	Indicates that the module has detected a system error.
Regular Flash	OFF	-	Indicates that the firmware is being updated.
Regular Flash	ON	-	Indicates that a module mismatch is detected.
Single Flash	OFF	-	Indicates that the module is energized and not configured.
Operational state			
ON	OFF	-	Indicates that the module is energized, configured and operational.
ON	-	ON	Indicates that the corresponding input channel is activated.
ON	-	OFF	Indicates that the corresponding input channel is deactivated.
ON	Regular Flash	OFF	Indicates one of the following: <ul style="list-style-type: none"> 24 Vdc field power error detection. Sensor power supply error detection.
ON	Regular Flash	Regular Flash	Indicates one of the following: <ul style="list-style-type: none"> Broken wire detection. Short circuit detection.

The following graphic depicts the system status of LEDs during module operation:

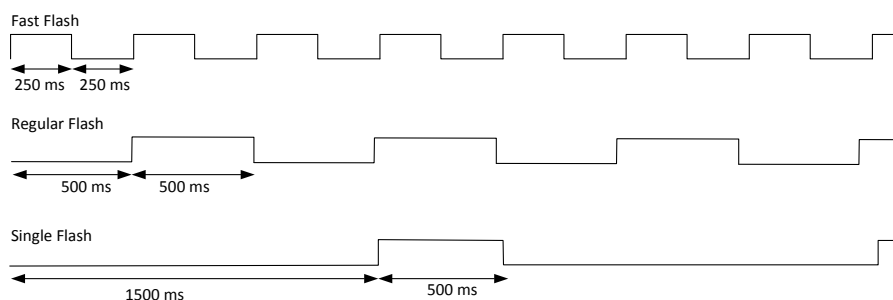

NTSDDI0402/NTSDDI0402H Characteristics

Overview

This section provides a general description of the characteristics of the module.

⚠ WARNING

UNINTENDED EQUIPMENT OPERATION

Do not exceed any of the rated values specified in the environmental and electrical characteristics tables.

Failure to follow these instructions can result in death, serious injury, or equipment damage.

For more information on environmental characteristics, refer to Modicon Edge I/O - System Planning and Installation Guide.

Dimensions

The following figure presents the external dimensions of the assembled module:

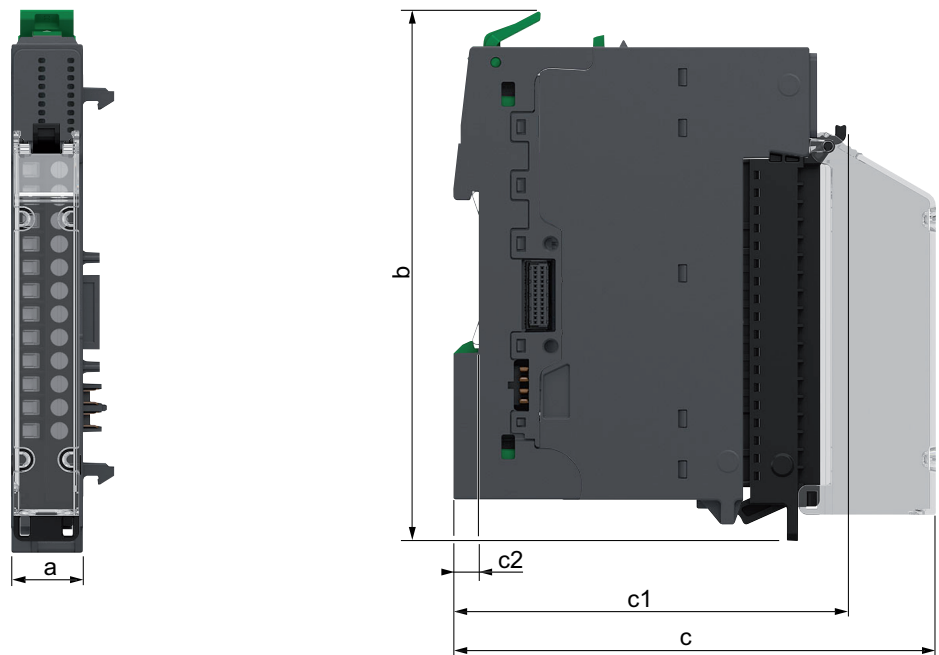

- a:** 15 mm (0.59 in)
- b:** 116.6 mm (4.57 in)
- c:** 107.5 mm (4.21 in)
- c1:** 88.2 mm (3.46 in)
- c2:** 5.6 mm (0.2 in)

Weight

- NTSDDI0402: 45 g (1.59 oz)
- NTSDDI0402K: 71 g (2.51 oz)
- NTSDDI0402H: 46 g (1.63 oz)
- NTSDDI0402HK: 73 g (2.57 oz)

General Characteristics

The following table describes the general characteristics of the NTSDDI0402/
NTSDDI0402H input modules:

Characteristics		Value	
Module		NTSDDI0402	NTSDDI0402H
Input compatibility		Configurable as Type 2 or Type 3 according to IEC 61131-2 with limitations linked to derating	
Field power supplied voltage requirements		<ul style="list-style-type: none"> From the 24 Vdc field power From a 12 Vdc or 24 Vdc external power supply 	
Power supplied voltage range		20.4...28.8 Vdc	
Bus current consumption		27.6 mA	28.8 mA
Field current consumption for sensors, per module		501.4 mA	
Power dissipation		1.42 W	
Maximum cable length	Shielded	1,000 m (3,280 ft)	
	Unshielded	600 m (1,968 ft)	
Isolation voltage	Between channels	No	
	Between groups	No	
	Between channel and bus	1,500 Vac	
	Between channel and functional earth ground	1,500 Vac	
Hot swap supported		Yes	
Operating ambient temperature derating		Depending on the sensor power supply load, the number of channels that can be used at different temperatures are provided in the following tables.	

The following table provides the derating of the NTSDDI0402/NTSDDI0402H modules with a sensor power supply load of 200 mA:

Mounting position	NTSDDI0402	NTSDDI0402H
Correct mounting position ⁽¹⁾	4 channels Type 3: up to 60 °C (140 °F) 4 channels Type 2: up to 55 °C (131 °F) 3 channels Type 2: 55...60 °C (131...140 °F) 2 channels Type 3 and 2 channels Type 2: up to 60 °C (140 °F)	4 channels Type 3: up to 70 °C (158 °F) 4 channels Type 2: up to 55 °C (131 °F) 3 channels Type 2: 55...60 °C (131...140 °F) 2 channels Type 2: 60...70 °C (140...158 °F) 2 channels Type 3 and 2 channels Type 2: up to 70 °C (158 °F)
Accepted mounting position ⁽¹⁾	4 channels Type 3: up to 55 °C (131 °F) 4 channels Type 2: up to 40 °C (104 °F) 3 channels Type 2: 40...45 °C (104...113 °F) 2 channels Type 2: 45...55 °C (113...131 °F) 2 channels Type 3 and 1 channel Type 2: up to 55 °C (131 °F)	4 channels Type 3: up to 60 °C (140 °F) 4 channels Type 2: up to 40 °C (104 °F) 3 channels Type 2: 40...45 °C (104...113 °F) 2 channels Type 2: 45...60 °C (113...140 °F) 2 channels Type 3 and 1 channel Type 2: up to 60 °C (140 °F) 1 channel Type 3 and 1 channel type 2: 50...55 °C (122...131 °F)
⁽¹⁾ For information about mounting positions, refer to Modicon Edge I/O - System Planning and Installation Guide.		

The following table provides the derating of the NTSDDI0402/NTSDDI0402H modules with a sensor power supply load of 500 mA:

Mounting position	NTSDDI0402	NTSDDI0402H
Correct mounting position ⁽¹⁾	4 channels Type 3: up to 60 °C (140 °F) 4 channels Type 2: up to 55 °C (131 °F) 3 channels Type 2: 55...60 °C (131...140 °F) 2 channels Type 3 and 2 channels Type 2: up to 60 °C (140 °F)	4 channels Type 3: up to 65 °C (149 °F) 3 channels Type 3: 65...70 °C (149...158 °F) 4 channels Type 2: up to 55 °C (131 °F) 3 channels Type 2: 55...60 °C (131...140 °F) 2 channels Type 2: 60...65 °C (140...149 °F) 1 channel Type 2: 65...70 °C (149...158 °F) 2 channels Type 3 and 2 channels Type 2: up to 60 °C (140 °F) 2 channels Type 3 and 1 channel Type 2: 60...65 °C (140...149 °F)
Accepted mounting position ⁽¹⁾	4 channels Type 3: up to 50 °C (122 °F) 3 channels Type 3: 50...55 °C (122...131 °F) 4 channels Type 2: up to 40 °C (104 °F) 3 channels Type 2: 40...45 °C (104...113 °F) 2 channels Type 2: 45...50 °C (113...122 °F) 1 channel Type 2: 50...55 °C (122...131 °F) 2 channels Type 3 and 1 channel Type 2: up to 50 °C (122 °F)	4 channels Type 3: up to 50 °C (122 °F) 3 channels Type 3: 50...60 °C (122...140 °F) 4 channels Type 2: up to 40 °C (104 °F) 3 channels Type 2: 40...45 °C (104...113 °F) 2 channels Type 2: 45...50 °C (113...122 °F) 1 channel Type 2: 50...60 °C (122...140 °F) 2 channels Type 3 and 1 channel Type 2: up to 50 °C (122 °F) 1 Channel Type 3 and 1 channel type 2: 50...55 °C (122...131 °F)
⁽¹⁾ For information about mounting positions, refer to Modicon Edge I/O - System Planning and Installation Guide.		

Input Characteristics

The table below describes the input characteristics of the NTSDDI0402/
NTSDDI0402H input modules:

Characteristics		Value
Input wiring mode		1-/2-/3-wire
Nominal input current		<ul style="list-style-type: none"> • 2.3 mA (Type 3) • 6.32 mA (Type 2)
Input voltage	Logic state 1	11...30 Vdc
	Logic state 0	< 5 Vdc
Input current	Logic state 1	<ul style="list-style-type: none"> • 2 mA minimum (Type 3) • 6 mA minimum (Type 2)
	Logic state 0	1.5 mA maximum
Input impedance		<ul style="list-style-type: none"> • 8 kΩ (Type 3) • 3.58 kΩ (Type 2)
Response time on input	Logic state 1 to logic state 0	< 10 μs
	Logic state 0 to logic state 1	< 20 μs
Input filter time	Hardware	< 100 μs
	Software	Configurable
Paralleling of inputs		Yes
Input protection		<ul style="list-style-type: none"> • Over voltage protection • Overcurrent protection on sensor supply • Reverse polarity protection
Input diagnostic		Broken wire Short circuit to ground for Type 3
Monitoring functions		<ul style="list-style-type: none"> • Broken wire detection on sensor input is possible with an additional resistor (R_{bwd}) in parallel: 39 kΩ, 1/16 W, 1%. • Internal power supply error detection. • Sensor supply error detection. • Short circuit to 24 Vdc detection is possible with an additional resistor (R_{short}) in series: 3.3 kΩ 1/4 W, 1%. <p>NOTE: Connect the resistors to the sensor connections.</p>

NTSDDI0402/NTSDDI0402H Wiring

Wiring Rules

For more information on the wiring, refer to Modicon Edge I/O - System Planning and Installation Guide.

Wiring Diagrams

This module allows the use of an external power supply to energize the sensors.

⚠ WARNING

UNINTENDED EQUIPMENT OPERATION

Use the sensor and actuator power supply only for supplying power to sensors or actuators connected to the module.

Failure to follow these instructions can result in death, serious injury, or equipment damage.

Wiring Using the Internal Power Supply

The following figure illustrates an example of 2-/3-wire connection sink inputs with the internal power supply:

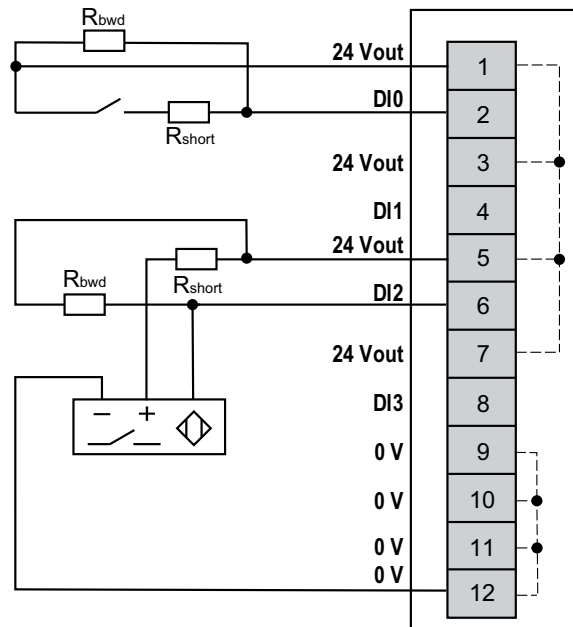

R_{bwd} (required when broken wire detection is enabled):

39 k Ω 1/16 W, 1%

R_{short} (required when short circuit detection is enabled):

3.3 k Ω 1/4 W, 1%

Wiring Using an External Power Supply

The following figure illustrates an example of 2-/3-wire connection sink inputs with an external power supply:

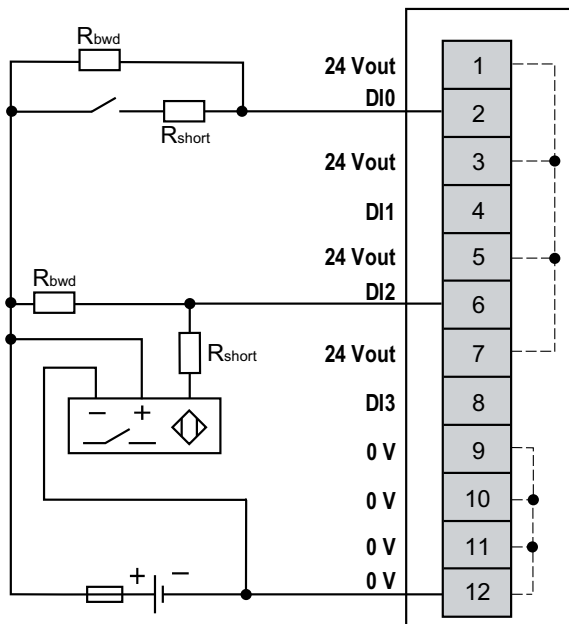

External Fuse: Type F, 0.1 A, 24 Vdc is mandatory and must be chosen in compliance with IEC60269 standard.

Rbwd (required when broken wire detection is enabled):
 39 kΩ 1/16 W, 1%

Rshort (required when short circuit detection is enabled):
 3.3 kΩ 1/4 W, 1%

NTSDDI0402/NTSDDI0402H Parameters

Parameters Description

Configurable Parameters

The following table presents the configurable parameters for the NTSDDI0402/NTSDDI0402H modules:

Displayed Name <i>Parameter Name</i>	Value	Data type	Description
Device Mode <i>DeviceMode</i>	0: Normal * 1: Optional 2: Virtual reserved	ENUM	Allows you to select the device mode: <ul style="list-style-type: none"> • Normal: The module is part of the software configuration and is physically connected in the cluster. • Optional: The module is part of the software configuration. A dummy module or the configured module must be physically installed in the cluster. Whether either module is present does not cause a configuration error to be detected. • Virtual reserved: The module is part of the software configuration. A dummy module must be physically installed in the cluster. If the virtual module is physically installed in the cluster, a configuration error is detected.
Diag Enable Broken Wire <i>DiagEnableBrokenWire</i> ⁽¹⁾	FALSE TRUE *	BOOL	Enables or disables the broken wire diagnostics.
Diag Enable Shorten Wire <i>DiagEnableShortenWire</i> ⁽¹⁾	FALSE TRUE *	BOOL	Enables or disables the short circuit diagnostics.
Diag Enable Sensor Power Supply <i>DiagEnableSensorPower-Supply</i> ⁽¹⁾	FALSE TRUE *	BOOL	Enables or disables the sensor power supply diagnostics.
Diag Enable internal field power supply <i>DiagEnablePDM</i> ⁽¹⁾	FALSE TRUE *	BOOL	Enables or disables the field power supply diagnostics.
* Parameter default value ⁽¹⁾ Online modification is allowed.			

The following table presents the configurable parameters for the channels of the
NTSDDI0402/NTSDDI0402H modules:

Displayed Name <i>Parameter Name</i>	Value	Data type	Description
Channel Enabled <i>ChannelEnable</i> ⁽¹⁾	TRUE* FALSE	BOOL	Determines whether a channel is enabled or disabled.
Latch <i>Latch</i> ⁽¹⁾	0: No* 1: Rising Edge - Automatic Acknowledge 2: Falling Edge - Automatic Acknowledge 3: Both Edges - Automatic Acknowledge 4: Rising Edge - Manual Acknowledge 5: Falling Edge - Manual Acknowledge 6: Both Edges - Manual Acknowledge	ENUM	Allows incoming pulses with a pulse width shorter than the network interface module scan time to be captured and recorded. For more information, refer to Input Latch, page 286.
Filter <i>Filter</i> ⁽¹⁾	Range: • 0...20 ms for Type 2 • 1...20 ms for Type 3 Interval: 0.1 ms 1.0 ms*	FLOAT	Allows reducing the effect of bounce on the input. Changes to the signal are only detected if the pulse width of the input signal is longer than the filter time.
Channel Type Selection <i>ChannelType_Sel</i> ⁽¹⁾	0: IEC Type 2 1*: IEC Type 3	ENUM	Allows you to select input channel type.
* Parameter default value (1) Online modification is allowed.			

Implicit Data

The following table presents the input implicit data for the module:

<i>Parameter Name</i>	<i>Value</i>	<i>Data type</i> <i>Size in bytes</i> <i>R/W</i>	<i>Description</i>
<i>GCS</i>	0...255	BYTE 1 R/-	Group Cyclic Status Bit 0: Data quality Bit 1: General module status Bit 2: I/O status Bit 3: N/A Bit 4: N/A Bit 5: Advisory status Bit 6: N/A Bit 7: Data freshness NOTE: For more information, refer to Modicon Edge I/O - Diagnostic Data - User Guide.
<i>ChannelHealth0_7</i> ⁽¹⁾	0...255	BYTE 1 R/-	Bit 0...7 = Status of channel 0...7 • Bit = FALSE: Channel is invalid or not present. • Bit = TRUE: Channel is valid or disabled.
<i>IValue0_7</i>	0...255	BYTE 1 R/-	Value of the input channels (Bit field). Bit 0...7 = Value of channel 0...7 NOTE: Unused bits are reserved.
⁽¹⁾ This parameter is not part of the implicit data if the optimized I/O profile is selected.			

The following table presents the output implicit data for the module:

<i>Parameter Name</i>	<i>Value</i>	<i>Data type</i> <i>Size in bytes</i> <i>R/W</i>	<i>Description</i>
<i>LatchAck0_7</i>	0...255	BYTE 1 R/W	At rising edge, resets the latch value of the input on the channel 0...7. Bit 0...7 = Value of channel 0...7

Explicit Data

The following table presents the explicit data for the channels of the module:

<i>Parameter Name</i>	<i>Value</i>	<i>Data type</i> <i>Size in bytes</i> <i>R/W</i>	<i>Description</i>
<i>ChannelFault</i>	0...255	BYTE R/-	Provides the following detected error on the channel: Bit 0: Broken wire error detected Bit 1: Short circuit error detected Bit 3: Sensor power supply error detected Bit 4: Internal power supply error detected NOTE: Unused bits are reserved.
<i>IValue</i>	TRUE = Channel is in logic state 1 FALSE = Channel is in logic state 0	BOOL R/-	Value of the input channel.
<i>LatchAck</i>	–	BOOL R/W	At rising edge, resets the latch value of the input on the channel.

NTSDDI0602 Discrete Input Module, 6 Inputs, 24 Vdc, Sink, 1-/2-/3-wire

What's in This Chapter

NTSDDI0602 Presentation.....	37
NTSDDI0602 Characteristics	41
NTSDDI0602 Wiring	44
NTSDDI0602 Parameters	45

NTSDDI0602 Presentation

Main Characteristics

The following table describes the main characteristics of the NTSDDI0602 input module:

Main Characteristics	Value
Product or component type	Discrete DC input module
Number of input channels	6
Groups of input channels	1 group of six channels
Nominal input voltage	24 Vdc
Input logic type	Sink
Operating mode	Synchronous and isochronous

Purchasing Information

The following figure shows the elements of the Modicon Edge I/O NTS NTSDDI0602 input module:

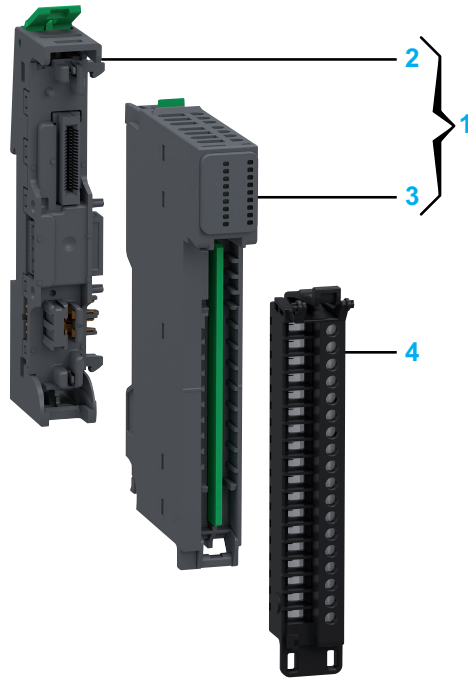

Number	Reference	Description
1	NTSDDI0602K	Base + Module (kit) NOTE: The module and its corresponding base can be purchased as a kit.
2	NTSXBA0100H	Spare Base, 1 Slot, for Input/Output Common or Expert Module, Hardened
3	NTSDDI0602	Discrete Input Module, 6 Inputs, 24 Vdc, Sink, 1-/2-/3-wire
4	NTSXTB18200H	Spring Terminal Block, 18 Points, 3.81 mm Pitch, Without Cover, use on Low Height Module, Hardened
	NTSXTB18201H	Spring Terminal Block, 18 Points, 3.81 mm Pitch, With Cover, use on Low Height Module, Hardened
	NTSXTB18000H	Screw Terminal Block, 18 Points, 3.81 mm Pitch, Without Cover, use on Low Height Module, Hardened
	NTSXTB18001H	Screw Terminal Block, 18 Points, 3.81 mm Pitch, With Cover, use on Low Height Module, Hardened
		NOTE: The terminal blocks are purchased separately.

NOTE: For more information on accessories and spare parts, refer to Modicon Edge I/O - System Planning and Installation Guide.

Physical Description

The following figure presents the elements of the module:

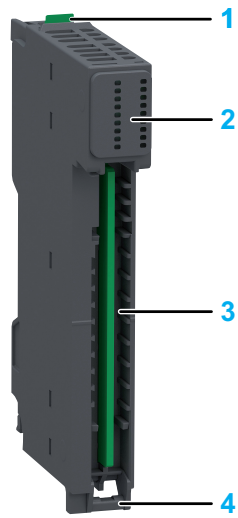

- 1: Release button for disengaging the module from the base
- 2: Status LEDs
- 3: Slot for the terminal block
- 4: Hinge for the terminal block installation

Status LEDs

The following figure presents the NTSDDI0602 status LEDs:



The following table describes the status of LEDs:

R (Green)	E (Red)	IN0...5 (Green)	Description
Initialization and non-operational states			
OFF	OFF	OFF	Indicates that the module is not energized.
OFF	Fast Flash	-	Indicates that the module has detected a system error.
Regular Flash	OFF	-	Indicates that the firmware is being updated.
Regular Flash	ON	-	Indicates that a module mismatch is detected.
Single Flash	OFF	-	Indicates that the module is energized and not configured.
Operational state			
ON	OFF	-	Indicates that the module is energized, configured and operational.
ON	-	ON	Indicates that the corresponding input channel is activated.
ON	-	OFF	Indicates that the corresponding input channel is deactivated.
ON	Regular Flash	OFF	Indicates one of the following: <ul style="list-style-type: none"> • 24 Vdc field power error detection. • Sensor power supply error detection.
ON	Regular Flash	Regular Flash	Indicates one of the following: <ul style="list-style-type: none"> • Broken wire detection. • Short circuit detection.

The following graphic depicts the system status of LEDs during module operation:

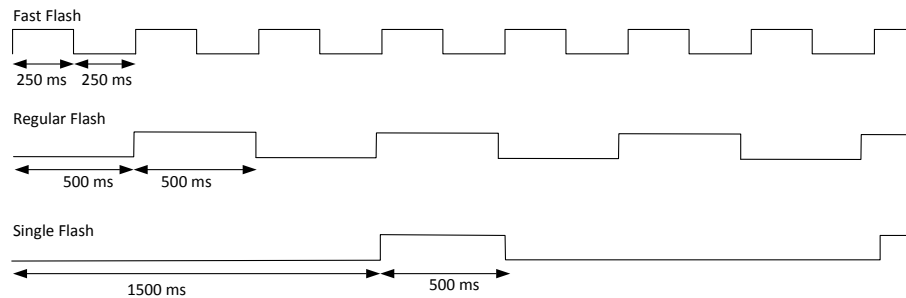

NTSDDI0602 Characteristics

Overview

This section provides a general description of the characteristics of the module.

⚠ WARNING
UNINTENDED EQUIPMENT OPERATION
Do not exceed any of the rated values specified in the environmental and electrical characteristics tables.
Failure to follow these instructions can result in death, serious injury, or equipment damage.

For more information on environmental characteristics, refer to Modicon Edge I/O - System Planning and Installation Guide.

Dimensions

The following figure presents the external dimensions of the assembled module:

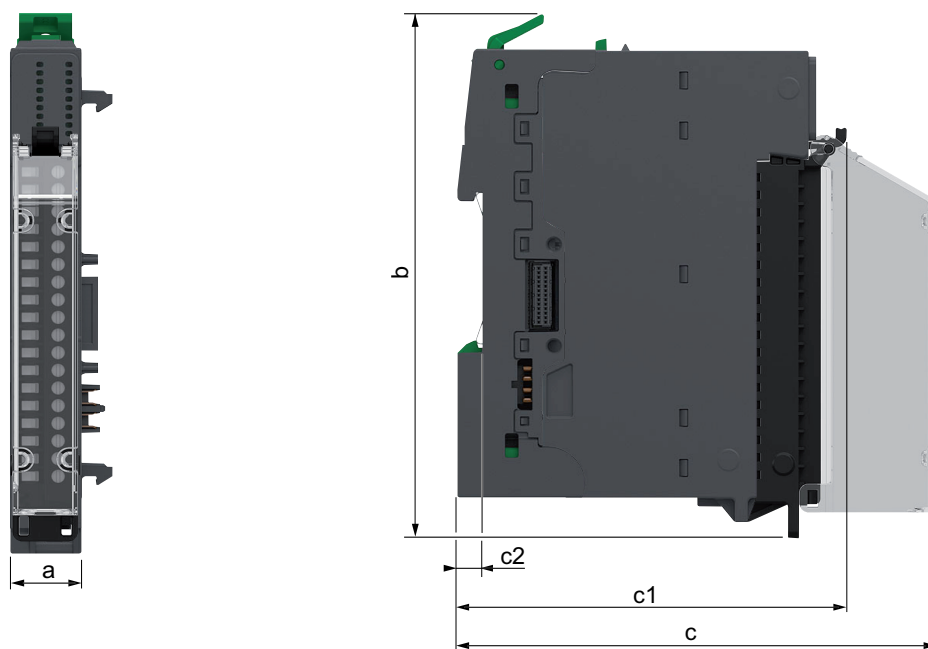

- a:** 15 mm (0.59 in)
- b:** 116.6 mm (4.57 in)
- c:** 107.5 mm (4.21 in)
- c1:** 88.2 mm (3.46 in)
- c2:** 5.6 mm (0.2 in)

Weight

- NTSDDI0602: 46 g (1.63 oz)
- NTSDDI0602K: 73 g (2.58 oz)

General Characteristics

The following table describes the general characteristics of the NTSDDI0602 input module:

Characteristics		Value
Input compatibility		Type 3 according to IEC 61131-2
Field power supplied voltage requirements		<ul style="list-style-type: none"> • From the 24 Vdc field power • From a common distribution module
Power supplied voltage range		20.4...28.8 Vdc
Bus current consumption		31.2 mA
Field current consumption for sensors, per module		510.1 mA
Power dissipation		1.40 W
Maximum cable length	Shielded	1,000 m (3,280 ft)
	Unshielded	600 m (1,968 ft)
Isolation voltage	Between channels	No
	Between groups	No
	Between channel and bus	1,500 Vac
	Between channel and functional earth ground	1,500 Vac
Hot swap supported		Yes
Operating ambient temperature derating		No derating

Input Characteristics

The table below describes the input characteristics of the NTSDDI0602 input module:

Characteristics		Value
Input wiring mode		1-/2-/3-wire
Nominal input current		2.5 mA
Input voltage	Logic state 1	11...30 Vdc
	Logic state 0	< 5 Vdc
Input current	Logic state 1	2 mA minimum
	Logic state 0	1.5 mA maximum
Input impedance		9.6 kΩ
Response time on input	Logic state 1 to logic state 0	< 125 μs
	Logic state 0 to logic state 1	< 125 μs
Input filter time	Hardware	< 100 μs
	Software	Configurable
Paralleling of inputs		Yes
Input protection		<ul style="list-style-type: none"> • Over voltage protection • Overcurrent protection on sensor supply • Reverse polarity protection
Input diagnostic		No
Monitoring functions		Power supply monitoring (under voltage, power absent)

NTSDDI0602 Wiring

Wiring Rules

For more information on the wiring, refer to Modicon Edge I/O - System Planning and Installation Guide.

Wiring Diagram

The following figure illustrates an example of 2-/3-wire connection inputs with the internal power supply:

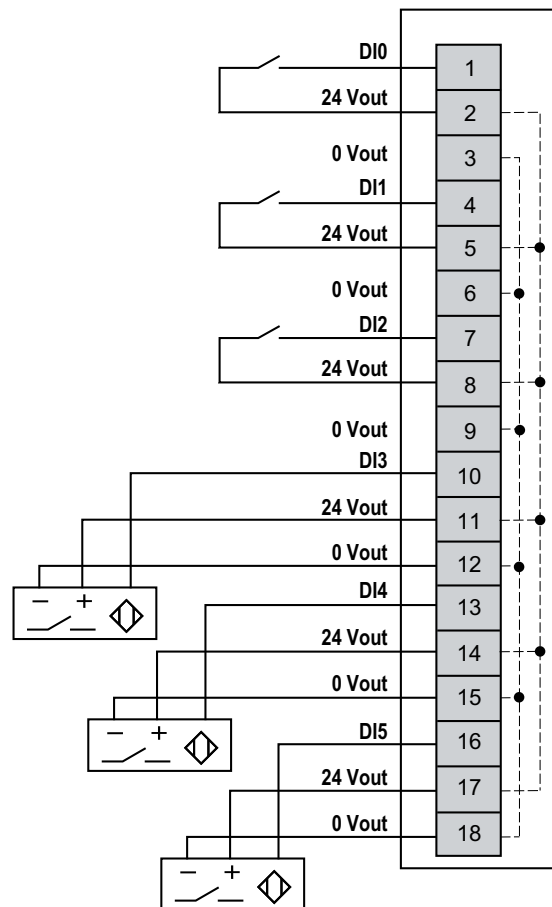

NTSDDI0602 Parameters

Parameters Description

Configurable Parameters

The following table presents the configurable parameters for the NTSDDI0602 module:

Displayed Name <i>Parameter Name</i>	Value	Data type	Description
Device Mode <i>DeviceMode</i>	0: Normal* 1: Optional 2: Virtual reserved	ENUM	Allows you to select the device mode: <ul style="list-style-type: none"> • Normal: The module is part of the software configuration and is physically connected in the cluster. • Optional: The module is part of the software configuration. A dummy module or the configured module must be physically installed in the cluster. Whether either module is present does not cause a configuration error to be detected. • Virtual reserved: The module is part of the software configuration. A dummy module must be physically installed in the cluster. If the virtual module is physically installed in the cluster, a configuration error is detected.
Diag Enable Sensor Power Supply <i>DiagEnableSensorPower-Supply⁽¹⁾</i>	FALSE TRUE*	BOOL	Enables or disables the sensor power supply diagnostics.
* Parameter default value ⁽¹⁾ Online modification is allowed.			

The following table presents the configurable parameters for the channels of the NTSDDI0602 module:

Displayed Name <i>Parameter Name</i>	Value	Data type	Description
Channel Enabled <i>ChannelEnable⁽¹⁾</i>	TRUE* FALSE	BOOL	Determines whether a channel is enabled or disabled.
Latch <i>Latch⁽¹⁾</i>	0: No* 1: Rising Edge - Automatic Acknowledge 2: Falling Edge - Automatic Acknowledge 3: Both Edges - Automatic Acknowledge 4: Rising Edge - Manual Acknowledge 5: Falling Edge - Manual Acknowledge 6: Both Edges - Manual Acknowledge	ENUM	Allows incoming pulses with a pulse width shorter than the network interface module scan time to be captured and recorded. For more information, refer to Input Latch , page 286.
Filter <i>Filter⁽¹⁾</i>	Range: 0...20 ms Interval: 0.1 ms 1.0 ms*	FLOAT	Allows reducing the effect of bounce on the input. Changes to the signal are only detected if the pulse width of the input signal is longer than the filter time.
* Parameter default value ⁽¹⁾ Online modification is allowed.			

Implicit Data

The following table presents the input implicit data for the module:

Parameter Name	Value	Data type Size in bytes R/W	Description
GCS	0...255	BYTE 1 R/-	Group Cyclic Status Bit 0: Data quality Bit 1: General module status Bit 2: I/O status Bit 3: N/A Bit 4: N/A Bit 5: Advisory status Bit 6: N/A Bit 7: Data freshness NOTE: For more information, refer to Modicon Edge I/O - Diagnostic Data - User Guide.
ChannelHealth0_7 ⁽¹⁾	0...255	BYTE 1 R/-	Bit 0...7 = Status of channel 0...7 <ul style="list-style-type: none"> Bit = FALSE: Channel is invalid or not present. Bit = TRUE: Channel is valid or disabled.
IValue0_7	0...255	BYTE 1 R/-	Value of the input channels (Bit field). Bit 0...7 = Value of channel 0...7 NOTE: Unused bits are reserved.

⁽¹⁾ This parameter is not part of the implicit data if the optimized I/O profile is selected.

The following table presents the output implicit data for the module:

Parameter Name	Value	Data type Size in bytes R/W	Description
LatchAck0_7	0...255	BYTE 1 R/W	At rising edge, resets the latch value of the input on the channel 0...7. Bit 0...7 = Value of channel 0...7

Explicit Data

The following table presents the explicit data for the channels of the module:

Parameter Name	Value	Data type Size in bytes R/W	Description
<i>ChannelFault</i>	0...255	BYTE R/-	Provides the following detected error on the channel: Bit 3: Sensor power supply error detected Bit 4: Internal power supply error detected NOTE: Unused bits are reserved.
<i>IValue</i>	TRUE = Channel is in logic state 1 FALSE = Channel is in logic state 0	BOOL R/-	Value of the input channel.
<i>LatchAck</i>	-	BOOL R/W	At rising edge, resets the latch value of the input on the channel.

NTSDDI0802X Discrete Input Module, 8 Inputs, 24 Vdc, Sink, 1-/2-wire

What's in This Chapter

NTSDDI0802X Presentation	48
NTSDDI0802X Characteristics	52
NTSDDI0802X Wiring	55
NTSDDI0802X Parameters	58

NTSDDI0802X Presentation

Main Characteristics

The following table describes the main characteristics of the NTSDDI0802X input module:

Main Characteristics	Value
Product or component type	Discrete DC input module
Number of Input channels	8
Groups of channels	1 group of 8 channels
Nominal input voltage	24 Vdc
Input logic type	Sink
Operating mode	Synchronous and isochronous

Purchasing Information

The following figure shows the elements of the Modicon Edge I/O NTS NTSDDI0802X input modules:

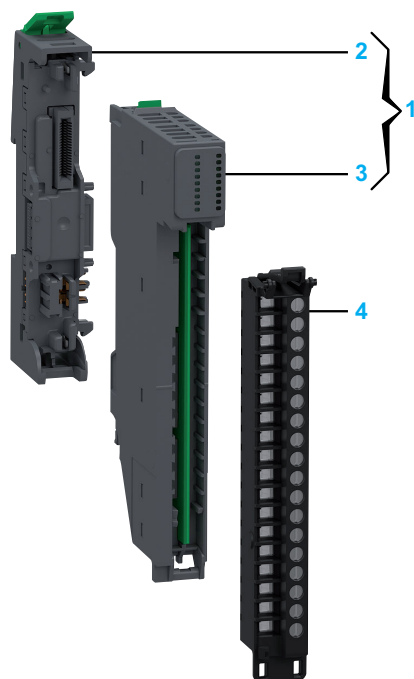

Number	Reference	Description
1	NTSDDI0802XK	Base + Module (kit) NOTE: The module and its corresponding base can be purchased as a kit.
2	NTSXBA0100H	Spare Base, 1 Slot, for Input/Output Common or Expert Module, Hardened
3	NTSDDI0802X	Discrete Input Module, 8 Inputs, 24 Vdc, Sink, 1-/2-wire
4	NTSXTB18200XH	Spring Terminal Block, 18 Points, 5 mm Pitch, Without Cover, use on High Height Module (X), Hardened
	NTSXTB18201XH	Spring Terminal Block, 18 Points, 5 mm Pitch, With Cover, use on High Height Module (X), Hardened
	NTSXTB18000XH	Screw Terminal Block, 18 Points, 5 mm Pitch, Without Cover, use on High Height Module (X), Hardened
	NTSXTB18001XH	Screw Terminal Block, 18 Points, 5 mm Pitch, With Cover, use on High Height Module (X), Hardened
		NOTE: The terminal blocks are purchased separately.

NOTE: For more information on accessories and spare parts, refer to Modicon Edge I/O - System Planning and Installation Guide.

Physical Description

The following figure presents the elements of the module:

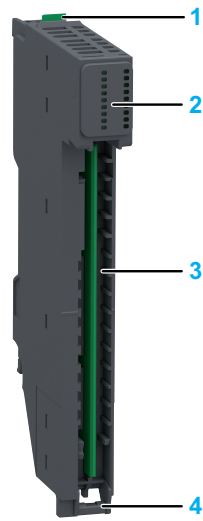

- 1: Release button for disengaging the module from the base
- 2: Status LEDs
- 3: Slot for the terminal block
- 4: Hinge for the terminal block installation

Status LEDs

The following figure presents the NTSDDI0802X status LEDs:



The following table describes the status of LEDs:

R (Green)	E (Red)	IN0...7 (Green)	Description
Initialization and non-operational states			
OFF	OFF	OFF	Indicates that the module is not energized.
OFF	Fast Flash	-	Indicates that the module has detected a system error.
Regular Flash	OFF	-	Indicates that the firmware is being updated.
Regular Flash	ON	-	Indicates that a module mismatch is detected.
Single Flash	OFF	-	Indicates that the module is energized and not configured.
Operational state			
ON	OFF	-	Indicates that the module is energized, configured and operational.
ON	-	ON	Indicates that the corresponding input channel is activated.
ON	-	OFF	Indicates that the corresponding input channel is deactivated.
ON	Regular Flash	OFF	Indicates one of the following: <ul style="list-style-type: none"> • 24 Vdc field power error detection. • Sensor power supply error detection.
ON	Regular Flash	Regular Flash	Indicates one of the following: <ul style="list-style-type: none"> • Broken wire detection. • Short circuit detection.

The following graphic depicts the system status of LEDs during module operation:

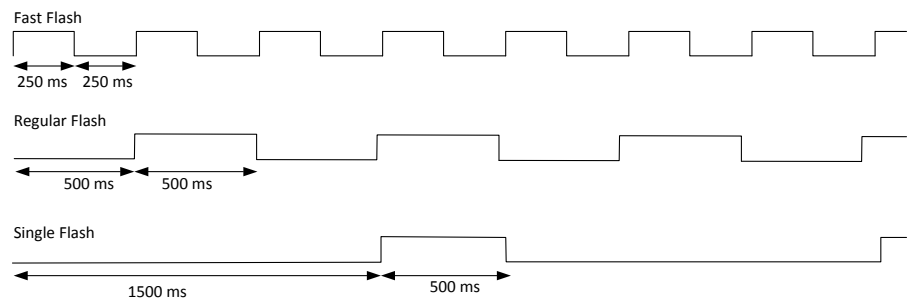

NTSDDI0802X Characteristics

Overview

This section provides a general description of the characteristics of the module.

⚠ WARNING

UNINTENDED EQUIPMENT OPERATION

Do not exceed any of the rated values specified in the environmental and electrical characteristics tables.

Failure to follow these instructions can result in death, serious injury, or equipment damage.

For more information on environmental characteristics, refer to Modicon Edge I/O - System Planning and Installation Guide.

Dimensions

The following figure presents the external dimensions of the assembled module:

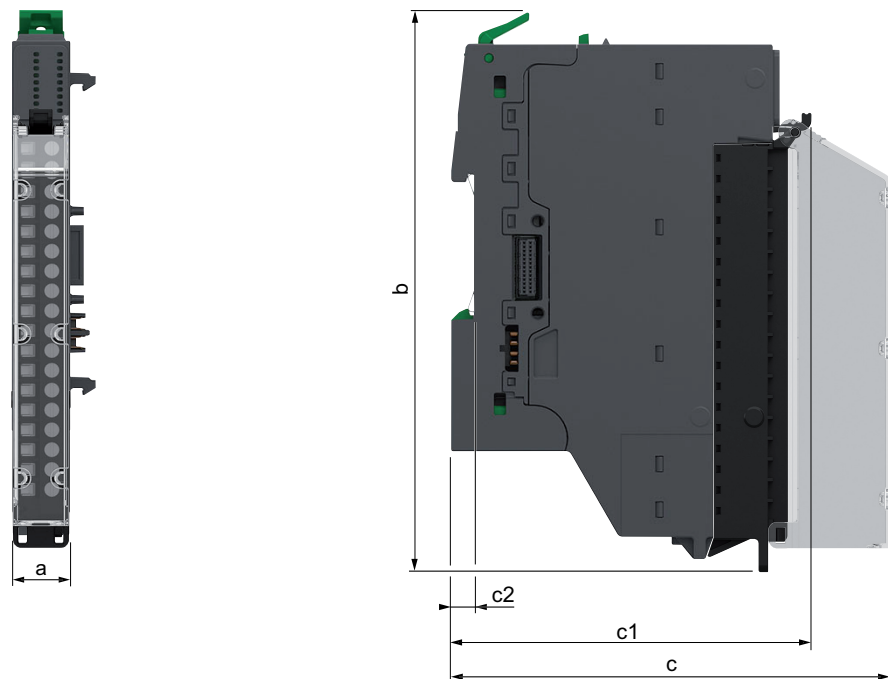

- a:** 15 mm (0.59 in)
- b:** 137.6 mm (5.39 in)
- c:** 107.5 mm (4.21 in)
- c1:** 88.2 mm (3.46 in)
- c2:** 5.6 mm (0.2 in)

Weight

- NTSDDI0802X: 49 g (1.73 oz)
- NTSDDI0802XK: 77 g (2.72 oz)

General Characteristics

The following table describes the general characteristics of the NTSDDI0802X input module:

Characteristics		Value
Input compatibility		Type 3 according to IEC 61131-2
Field power supplied voltage requirements		<ul style="list-style-type: none"> • From the 24 Vdc field power • From a common distribution module
Power supplied voltage range		20.4...28.8 Vdc
Bus current consumption		32.4 mA
Field current consumption for sensors, per module		210.1 mA
Power dissipation		1.60 W
Maximum cable length	Shielded	1,000 m (3,280 ft)
	Unshielded	600 m (1,968 ft)
Isolation voltage	Between channels	No
	Between groups	No
	Between channel and bus	1,500 Vac
	Between channel and functional earth ground	1,500 Vac
Hot swap supported		Yes
Operating ambient temperature derating		No derating

Input Characteristics

The table below describes the input characteristics of the NTSDDI0802X input module:

Characteristics		Value
Input wiring mode		1-wire, 2-wire
Nominal input current		2.5 mA
Input voltage	Logic state 1	11...30 Vdc
	Logic state 0	< 5 Vdc
Input current	Logic state 1	2 mA minimum
	Logic state 0	1.5 mA maximum
Input impedance		9.6 kΩ
Response time on input	Logic state 1 to logic state 0	< 60 μs
	Logic state 0 to logic state 1	< 90 μs
Input filter time	Hardware	< 100 μs
	Software	Configurable
Paralleling of inputs		Yes
Input protection		<ul style="list-style-type: none"> • Over voltage protection • Overcurrent protection on sensor supply • Reverse polarity protection
Input diagnostic		No
Monitoring functions		Power supply monitoring (under voltage, power absent)

NTSDDI0802X Wiring

Wiring Rules

For more information on the wiring, refer to Modicon Edge I/O - System Planning and Installation Guide.

Wiring Diagrams

This module allows the use of an external power supply to energize the sensors.

⚠ WARNING

UNINTENDED EQUIPMENT OPERATION

Use the sensor and actuator power supply only for supplying power to sensors or actuators connected to the module.

Failure to follow these instructions can result in death, serious injury, or equipment damage.

The following figure illustrates an example of 1-wire connection inputs with common module NTSPCM1600H:

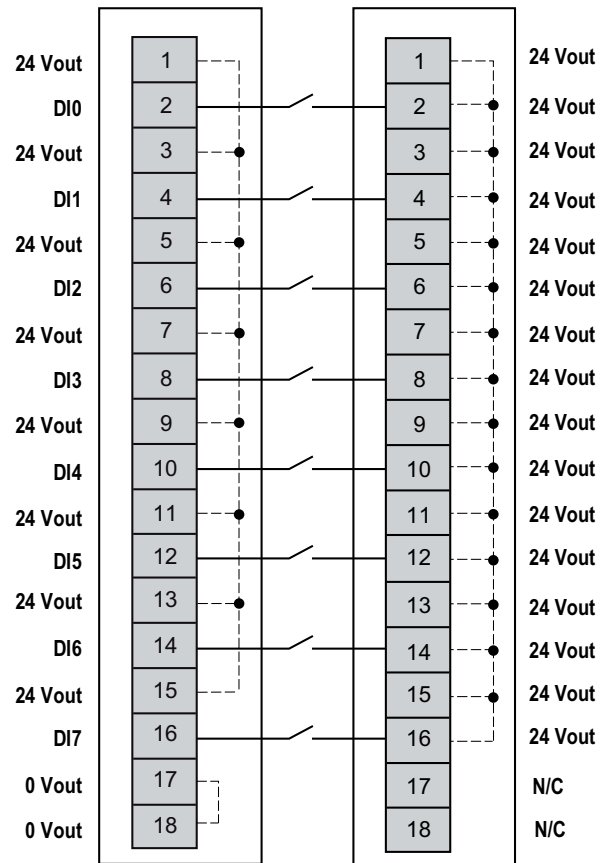

N/C: No Connection

⚠ WARNING

UNINTENDED EQUIPMENT OPERATION

Do not connect wires to unused terminals and/or terminals indicated as “No Connection (N/C)”.

Failure to follow these instructions can result in death, serious injury, or equipment damage.

The following figure illustrates an example of 2-wire connection inputs with the internal power supply:

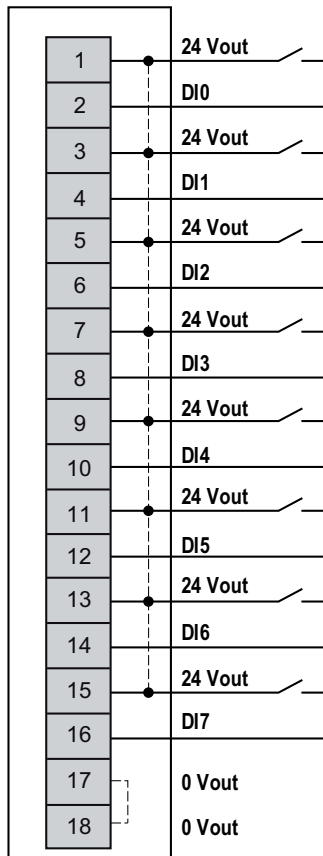

NTSDDI0802X Parameters

Parameters Description

Configurable Parameters

The following table presents the configurable parameters for the NTSDDI0802X module:

Displayed Name <i>Parameter Name</i>	Value	Data type	Description
Device Mode <i>DeviceMode</i>	0: Normal* 1: Optional 2: Virtual reserved	ENUM	Allows you to select the device mode: <ul style="list-style-type: none"> • Normal: The module is part of the software configuration and is physically connected in the cluster. • Optional: The module is part of the software configuration. A dummy module or the configured module must be physically installed in the cluster. Whether either module is present does not cause a configuration error to be detected. • Virtual reserved: The module is part of the software configuration. A dummy module must be physically installed in the cluster. If the virtual module is physically installed in the cluster, a configuration error is detected.
Diag Enable Sensor Power Supply <i>DiagEnableSensorPower-Supply⁽¹⁾</i>	FALSE TRUE*	BOOL	Enables or disables the sensor power supply diagnostics.
* Parameter default value ⁽¹⁾ Online modification is allowed.			

The following table presents the configurable parameters for the channels of the NTSDDI0802X module:

Displayed Name <i>Parameter Name</i>	Value	Data type	Description
Channel Enabled <i>ChannelEnable⁽¹⁾</i>	TRUE* FALSE	BOOL	Determines whether a channel is enabled or disabled.
Latch <i>Latch⁽¹⁾</i>	0: No* 1: Rising Edge - Automatic Acknowledge 2: Falling Edge - Automatic Acknowledge 3: Both Edges - Automatic Acknowledge 4: Rising Edge - Manual Acknowledge 5: Falling Edge - Manual Acknowledge 6: Both Edges - Manual Acknowledge	ENUM	Allows incoming pulses with a pulse width shorter than the network interface module scan time to be captured and recorded. For more information, refer to Input Latch , page 286.
Filter <i>Filter⁽¹⁾</i>	Range: 0...20 ms Interval: 0.1 ms 1.0 ms*	FLOAT	Allows reducing the effect of bounce on the input. Changes to the signal are only detected if the pulse width of the input signal is longer than the filter time.
* Parameter default value ⁽¹⁾ Online modification is allowed.			

Implicit Data

The following table presents the input implicit data for the module:

Parameter Name	Value	Data type Size in bytes R/W	Description
<i>GCS</i>	0...255	BYTE 1 R/-	Group Cyclic Status Bit 0: Data quality Bit 1: General module status Bit 2: I/O status Bit 3: N/A Bit 4: N/A Bit 5: Advisory status Bit 6: N/A Bit 7: Data freshness NOTE: For more information, refer to Modicon Edge I/O - Diagnostic Data - User Guide.
<i>ChannelHealth0_7</i> ⁽¹⁾	0...255	BYTE 1 R/-	Bit 0...7 = Status of channel 0...7 <ul style="list-style-type: none"> • Bit = FALSE: Channel is invalid or not present. • Bit = TRUE: Channel is valid or disabled.
<i>IValue0_7</i>	0...255	BYTE 1 R/-	Value of the input channels (Bit field). Bit 0...7 = Value of channel 0...7 NOTE: Unused bits are reserved.
⁽¹⁾ This parameter is not part of the implicit data if the optimized I/O profile is selected.			

The following table presents the output implicit data for the module:

Parameter Name	Value	Data type Size in bytes R/W	Description
<i>LatchAck0_7</i>	0...255	BYTE 1 R/W	At rising edge, resets the latch value of the input on the channel 0...7. Bit 0...7 = Value of channel 0...7

Explicit Data

The following table presents the explicit data for the channels of the module:

Parameter Name	Value	Data type Size in bytes R/W	Description
<i>ChannelFault</i>	0...255	BYTE R/-	Provides the following detected error on the channel: Bit 3: Sensor power supply error detected Bit 4: Internal power supply error detected NOTE: Unused bits are reserved.
<i>IValue</i>	TRUE = Channel is in logic state 1 FALSE = Channel is in logic state 0	BOOL R/-	Value of the input channel.
<i>LatchAck</i>	–	BOOL R/W	At rising edge, resets the latch value of the input on the channel.

NTSDDI1602 Discrete Input Module, 16 Inputs, 24 Vdc, Sink, 1-wire

What's in This Chapter

NTSDDI1602 Presentation.....	61
NTSDDI1602 Characteristics	65
NTSDDI1602 Wiring	68
NTSDDI1602 Parameters	70

NTSDDI1602 Presentation

Main Characteristics

The following table describes the main characteristics of the NTSDDI1602 input module :

Main Characteristics	Value
Product or component type	Discrete DC input module
Number of Input channels	16
Groups of channels	1 group of 16 channels
Nominal input voltage	24 Vdc
Input logic type	Sink
Operating mode	Synchronous and isochronous

Purchasing Information

The following figure shows the elements of the Modicon Edge I/O NTS NTSDDI1602 input module:

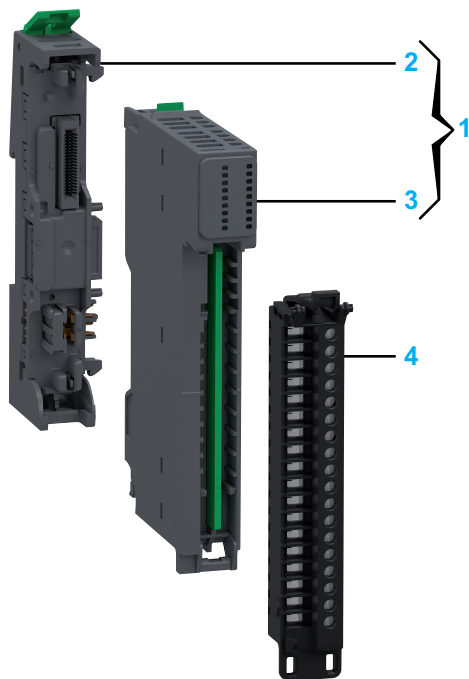

Number	Reference	Description
1	NTSDDI1602K	Base + Module (kit) NOTE: The module and its corresponding base can be purchased as a kit.
2	NTSXBA0100H	Spare Base, 1 Slot, for Input/Output Common or Expert Module, Hardened
3	NTSDDI1602	Discrete Input Module, 16 Inputs, 24 Vdc, Sink, 1-wire
4	NTSXTB18200H	Spring Terminal Block, 18 Points, 3.81 mm Pitch, Without Cover, use on Low Height Module, Hardened
	NTSXTB18201H	Spring Terminal Block, 18 Points, 3.81 mm Pitch, With Cover, use on Low Height Module, Hardened
	NTSXTB18000H	Screw Terminal Block, 18 Points, 3.81 mm Pitch, Without Cover, use on Low Height Module, Hardened
	NTSXTB18001H	Screw Terminal Block, 18 Points, 3.81 mm Pitch, With Cover, use on Low Height Module, Hardened
		NOTE: The terminal blocks are purchased separately.

NOTE: For more information on accessories and spare parts, refer to Modicon Edge I/O - System Planning and Installation Guide.

Physical Description

The following figure presents the elements of the module:

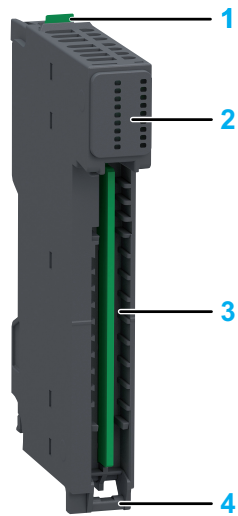

- 1: Release button for disengaging the module from the base
- 2: Status LEDs
- 3: Slot for the terminal block
- 4: Hinge for the terminal block installation

Status LEDs

The following figure presents the NTSDDI1602 status LEDs:



The following table describes the status of LEDs:

R (Green)	E (Red)	IN0...15 (Green)	Description
Initialization and non-operational states			
OFF	OFF	OFF	Indicates that the module is not energized.
OFF	Fast Flash	-	Indicates that the module has detected a system error.
Regular Flash	OFF	-	Indicates that the firmware is being updated.
Regular Flash	ON	-	Indicates that a module mismatch is detected.
Single Flash	OFF	-	Indicates that the module is energized and not configured.
Operational state			
ON	OFF	-	Indicates that the module is energized, configured and operational.
ON	-	ON	Indicates that the corresponding input channel is activated.
ON	-	OFF	Indicates that the corresponding input channel is deactivated.
ON	Regular Flash	OFF	Indicates one of the following: <ul style="list-style-type: none"> • 24 Vdc field power error detection. • Sensor power supply error detection.

The following graphic depicts the system status of LEDs during module operation:

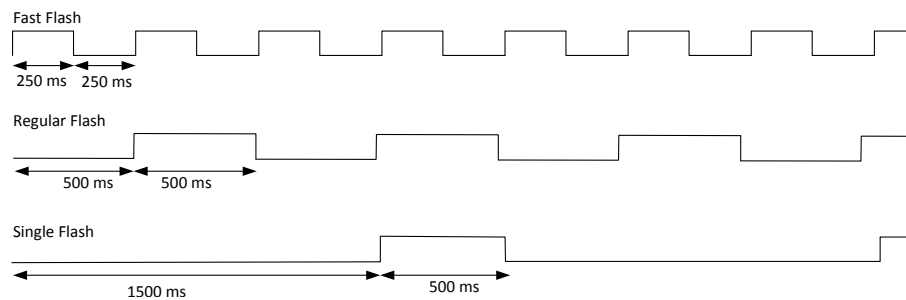

NTSDDI1602 Characteristics

Overview

This section provides a general description of the characteristics of the module.

⚠ WARNING
UNINTENDED EQUIPMENT OPERATION
Do not exceed any of the rated values specified in the environmental and electrical characteristics tables.
Failure to follow these instructions can result in death, serious injury, or equipment damage.

For more information on environmental characteristics, refer to Modicon Edge I/O - System Planning and Installation Guide.

Dimensions

The following figure presents the external dimensions of the assembled module:

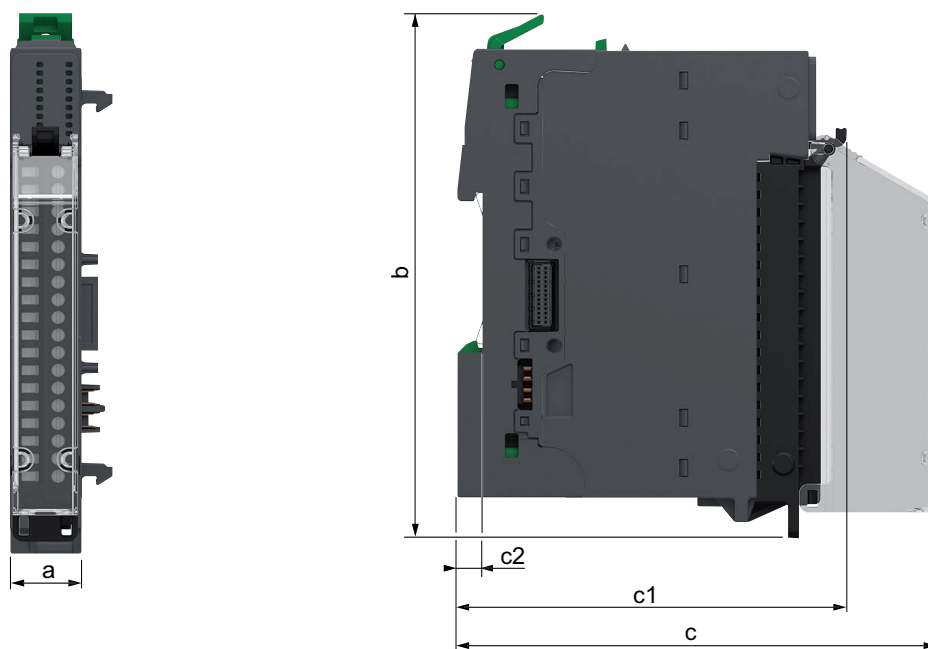

- a:** 15 mm (0.59 in)
- b:** 116.6 mm (4.57 in)
- c:** 107.5 mm (4.21 in)
- c1:** 88.2 mm (3.46 in)
- c2:** 5.6 mm (0.2 in)

Weight

- NTSDDI1602: 46 g (1.63 oz)
- NTSDDI1602K: 73 g (2.58 oz)

General Characteristics

The following table describes the general characteristics of the NTSDDI1602 input module:

Characteristics		Value	
Input compatibility		Type 3 according to IEC 61131-2	
Field power supplied voltage requirements		<ul style="list-style-type: none"> • From a common distribution module • From an external power supply (0 Vdc connected to the field power 0 Vdc). 	
Power supplied voltage range		20.4...28.8 Vdc	
Bus current consumption		40.8 mA	
Field current consumption for sensors, per module		2.9 mA	
Power dissipation		2.20 W	
Maximum cable length	Shielded	1,000 m (3,280 ft)	
	Unshielded	600 m (1,968 ft)	
Isolation voltage	Between channels	No	
	Between groups	No	
	Between channel and bus	1,500 Vac	
	Between channel and functional earth ground	1,500 Vac	
Hot swap supported		Yes	
Operating ambient temperature derating	Nominal voltage 24 Vdc	Correct mounting position ⁽¹⁾	16 channels: up to 55 °C (131 °F) 12 channels: 55...60 °C (131...140 °F)
		Accepted mounting position ⁽¹⁾	16 channels: up to 50 °C (122 °F) 12 channels: 50...55 °C (122...131 °F)
	Nominal voltage 28.8 Vdc	Correct mounting position ⁽¹⁾	16 channels: up to 50 °C (122 °F) 12 channels: 50...55 °C (122...131 °F) 8 channels: 55...60 °C (131...140 °F)
		Accepted mounting position ⁽¹⁾	16 channels: up to 45 °C (113 °F) 12 channels: 45...50 °C (113...122 °F) 8 channels: 50...55 °C (122...131 °F)
⁽¹⁾ For information about mounting positions, refer to Modicon Edge I/O - System Planning and Installation Guide.			

Input Characteristics

The table below describes the input characteristics of the NTSDDI1602 input module:

Characteristics		Value
Input wiring mode		1-wire
Nominal input current		2.5 mA
Input voltage	Logic state 1	11...30 Vdc
	Logic state 0	< 5 Vdc
Input current	Logic state 1	2 mA minimum
	Logic state 0	1.5 mA maximum
Input impedance		9.6 kΩ
Response time on input	Logic state 1 to logic state 0	< 125 μs
	Logic state 0 to logic state 1	< 125 μs
Input filter time	Hardware	< 100 μs
	Software	Configurable
Paralleling of inputs		Yes
Input protection		<ul style="list-style-type: none"> • Over voltage protection • Overcurrent protection on sensor supply • Reverse polarity protection
Input diagnostic		No
Monitoring functions		Power supply monitoring (under voltage, power absent)

NTSDDI1602 Wiring

Wiring Rules

For more information on the wiring, refer to Modicon Edge I/O - System Planning and Installation Guide.

Wiring Diagrams

This module allows the use of an external power supply to energize the sensors.

⚠ WARNING

UNINTENDED EQUIPMENT OPERATION

Use the sensor and actuator power supply only for supplying power to sensors or actuators connected to the module.

Failure to follow these instructions can result in death, serious injury, or equipment damage.

The following figure illustrates an example of 1-wire connection inputs with an external power supply:

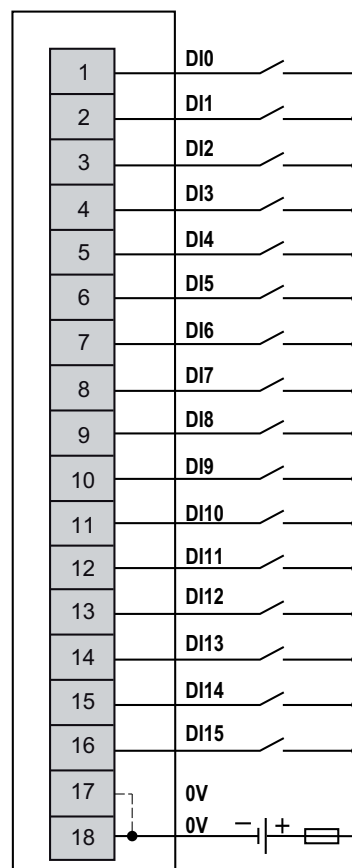

External Fuse: Type F, 0.5 A, 24 Vdc is mandatory and must be chosen in compliance with IEC60269 standard.

The following figure illustrates an example of 1-wire connection inputs with common module NTSPCM1600H:

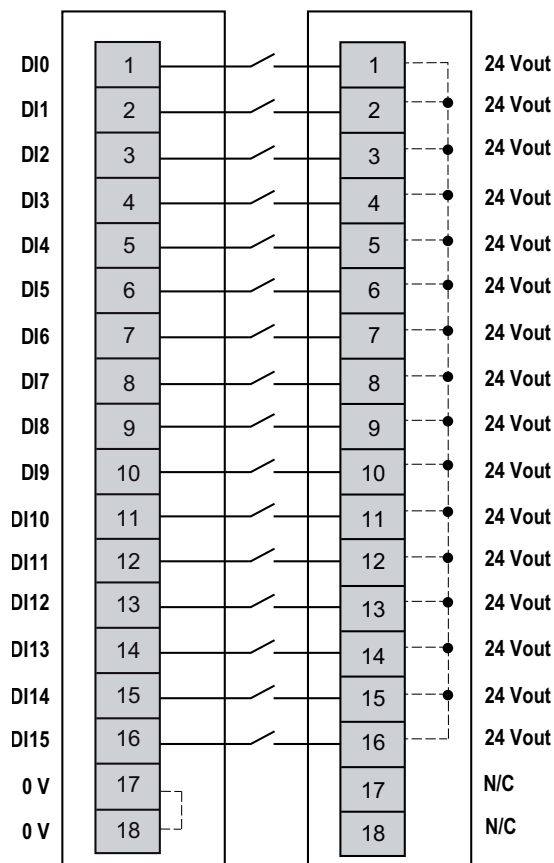

N/C: No Connection

⚠ WARNING

UNINTENDED EQUIPMENT OPERATION

Do not connect wires to unused terminals and/or terminals indicated as “No Connection (N/C)”.

Failure to follow these instructions can result in death, serious injury, or equipment damage.

NTSDDI1602 Parameters

Parameters Description

Configurable Parameters

The following table presents the configurable parameters for the NTSDDI1602 module:

Displayed Name <i>Parameter Name</i>	Value	Data type	Description
Device Mode <i>DeviceMode</i>	0: Normal* 1: Optional 2: Virtual reserved	ENUM	Allows you to select the device mode: <ul style="list-style-type: none"> • Normal: The module is part of the software configuration and is physically connected in the cluster. • Optional: The module is part of the software configuration. A dummy module or the configured module must be physically installed in the cluster. Whether either module is present does not cause a configuration error to be detected. • Virtual reserved: The module is part of the software configuration. A dummy module must be physically installed in the cluster. If the virtual module is physically installed in the cluster, a configuration error is detected.
* Parameter default value			

The following table presents the configurable parameters for the channels of the NTSDDI1602 module:

Displayed Name <i>Parameter Name</i>	Value	Data type	Description
Channel Enabled <i>ChannelEnable⁽¹⁾</i>	TRUE* FALSE	BOOL	Determines whether a channel is enabled or disabled.
Latch <i>Latch⁽¹⁾</i>	0: No* 1: Rising Edge - Automatic Acknowledge 2: Falling Edge - Automatic Acknowledge 3: Both Edges - Automatic Acknowledge 4: Rising Edge - Manual Acknowledge 5: Falling Edge - Manual Acknowledge 6: Both Edges - Manual Acknowledge	ENUM	Allows incoming pulses with a pulse width shorter than the network interface module scan time to be captured and recorded. For more information, refer to Input Latch, page 286.
Filter <i>Filter⁽¹⁾</i>	Range: 0...20 ms Interval: 0.1 ms 1.0 ms*	FLOAT	Allows reducing the effect of bounce on the input. Changes to the signal are only detected if the pulse width of the input signal is longer than the filter time.
* Parameter default value ⁽¹⁾ Online modification is allowed.			

Implicit Data

The following table presents the input implicit data for the module:

Parameter Name	Value	Data type Size in bytes R/W	Description
GCS	0...255	BYTE 1 R/-	Group Cyclic Status Bit 0: Data quality Bit 1: General module status Bit 2: I/O status Bit 3: N/A Bit 4: N/A Bit 5: Advisory status Bit 6: N/A Bit 7: Data freshness NOTE: For more information, refer to Modicon Edge I/O - Diagnostic Data - User Guide.
ChannelHealth0_7 ⁽¹⁾	0...255	BYTE 1 R/-	Bit 0...7 = Status of channel 0...7 • Bit = FALSE: Channel is invalid or not present. • Bit = TRUE: Channel is valid or disabled.
ChannelHealth8_15 ⁽¹⁾	0...255	BYTE 1 R/-	Bit 0...7 = Status of channel 8...15 • Bit = FALSE: Channel is invalid or not present. • Bit = TRUE: Channel is valid or disabled.
IValue0_7	0...255	BYTE 1 R/-	Value of the input channels (Bit field). Bit 0...7 = Value of channel 0...7 NOTE: Unused bits are reserved.
IValue8_15	0...255	BYTE 1 R/-	Value of the input channels (Bit field). Bit 0...7 = Value of channel 8...15 NOTE: Unused bits are reserved.

⁽¹⁾ This parameter is not part of the implicit data if the optimized I/O profile is selected.

The following table presents the output implicit data for the module:

Parameter Name	Value	Data type Size in bytes R/W	Description
LatchAck0_7	0...255	BYTE 1 R/W	At rising edge, resets the latch value of the input on the channel 0...7. Bit 0...7 = Value of channel 0...7
LatchAck8_15	0...255	BYTE 1 R/W	At rising edge, resets the latch value of the input on the channel 8...15. Bit 0...7 = Value of channel 8...15

Explicit Data

The following table presents the explicit data for the channels of the module:

Parameter Name	Value	Data type Size in bytes R/W	Description
<i>ChannelFault</i>	0...255	BYTE R/-	Provides the following detected error on the channel: Bit 4: Internal power supply error detected NOTE: Unused bits are reserved.
<i>IValue</i>	TRUE = Channel is in logic state 1 FALSE = Channel is in logic state 0	BOOL R/-	Value of the input channel.
<i>LatchAck</i>	–	BOOL R/W	At rising edge, resets the latch value of the input on the channel.

NTSDDI1602X/NTSDDI1602XH Discrete Input Module, 16 Inputs, 24 Vdc, Sink, 1-/2-/3-wire, Standard/Hardened

What's in This Chapter

NTSDDI1602X/NTSDDI1602XH Presentation	73
NTSDDI1602X/NTSDDI1602XH Characteristics	77
NTSDDI1602X/NTSDDI1602XH Wiring	80
NTSDDI1602X/NTSDDI1602XH Parameters.....	83

NTSDDI1602X/NTSDDI1602XH Presentation

Main Characteristics

The following table describes the main characteristics of the NTSDDI1602X/
NTSDDI1602XH input modules:

Main Characteristics	Value
Product or component type	Discrete DC input module
Number of Input channels	16
Groups of channels	4 group of 4 channels
Nominal input voltage	24 Vdc
Input logic type	Sink
Operating mode	Synchronous and isochronous

Purchasing Information

The following figure shows the elements of the Modicon Edge I/O NTS
NTSDDI1602X/NTSDDI1602XH input modules:

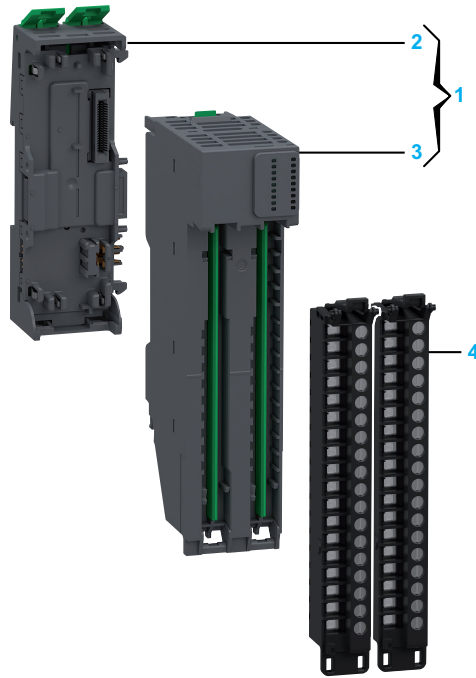

Number	Reference	Description
1	NTSDDI1602XK NTSDDI1602XHK	Base + Module (kit) NOTE: The module and its corresponding base can be purchased as a kit.
2	NTSXBA0200H	Spare Base, 2 Slots, for Input/Output Common/Expert/Safety Module, Hardened
3	NTSDDI1602X NTSDDI1602XH	Discrete Input Module, 16 Inputs, 24 Vdc, Sink, 1-/2-/3-wire Discrete Input Module, 16 Inputs, 24 Vdc, Sink, 1-/2-/3-wire, Hardened
4	NTSXTB18200XH NTSXTB18201XH NTSXTB18000XH NTSXTB18001XH	Spring Terminal Block, 18 Points, 5 mm Pitch, Without Cover, use on High Height Module (X), Hardened Spring Terminal Block, 18 Points, 5 mm Pitch, With Cover, use on High Height Module (X), Hardened Screw Terminal Block, 18 Points, 5 mm Pitch, Without Cover, use on High Height Module (X), Hardened Screw Terminal Block, 18 Points, 5 mm Pitch, With Cover, use on High Height Module (X), Hardened NOTE: The terminal blocks are purchased separately.

NOTE: For more information on accessories and spare parts, refer to Modicon Edge I/O - System Planning and Installation Guide.

Physical Description

The following figure presents the elements of the module:

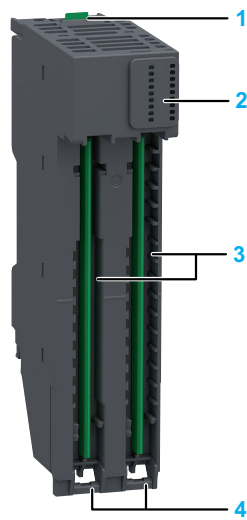

- 1: Release button for disengaging the module from the base
- 2: Status LEDs
- 3: Slot for the terminal block
- 4: Hinge for the terminal block installation

Status LEDs

The following figure presents the NTSDDI1602X/NTSDDI1602XH status LEDs:

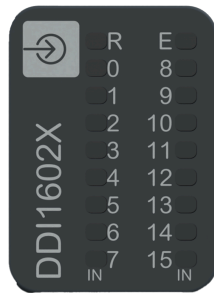

The following table describes the status of LEDs:

R (Green)	E (Red)	IN0...15 (Green)	Description
Initialization and non-operational states			
OFF	OFF	OFF	Indicates that the module is not energized.
OFF	Fast Flash	-	Indicates that the module has detected a system error.
Regular Flash	OFF	-	Indicates that the firmware is being updated.
Regular Flash	ON	-	Indicates that a module mismatch is detected.
Single Flash	OFF	-	Indicates that the module is energized and not configured.
Operational state			
ON	OFF	-	Indicates that the module is energized, configured and operational.
ON	-	ON	Indicates that the corresponding input channel is activated.
ON	-	OFF	Indicates that the corresponding input channel is deactivated.
ON	Regular Flash	OFF	Indicates one of the following: <ul style="list-style-type: none"> • 24 Vdc field power error detection. • Sensor power supply error detection.

The following graphic depicts the system status of LEDs during module operation:

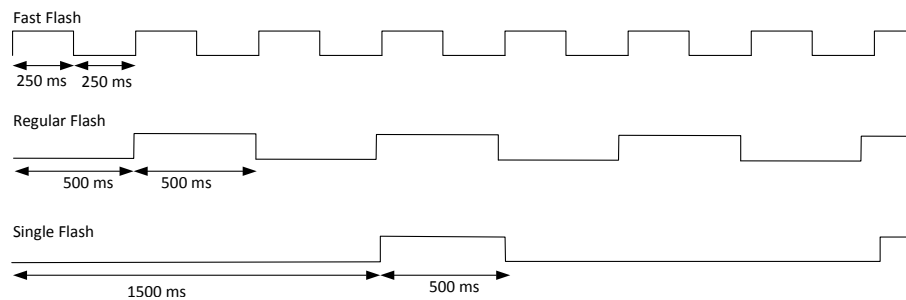

NTSDDI1602X/NTSDDI1602XH Characteristics

Overview

This section provides a general description of the characteristics of the module.

⚠ WARNING
UNINTENDED EQUIPMENT OPERATION
Do not exceed any of the rated values specified in the environmental and electrical characteristics tables.
Failure to follow these instructions can result in death, serious injury, or equipment damage.

For more information on environmental characteristics, refer to Modicon Edge I/O - System Planning and Installation Guide.

Dimensions

The following figure presents the external dimensions of the assembled module:

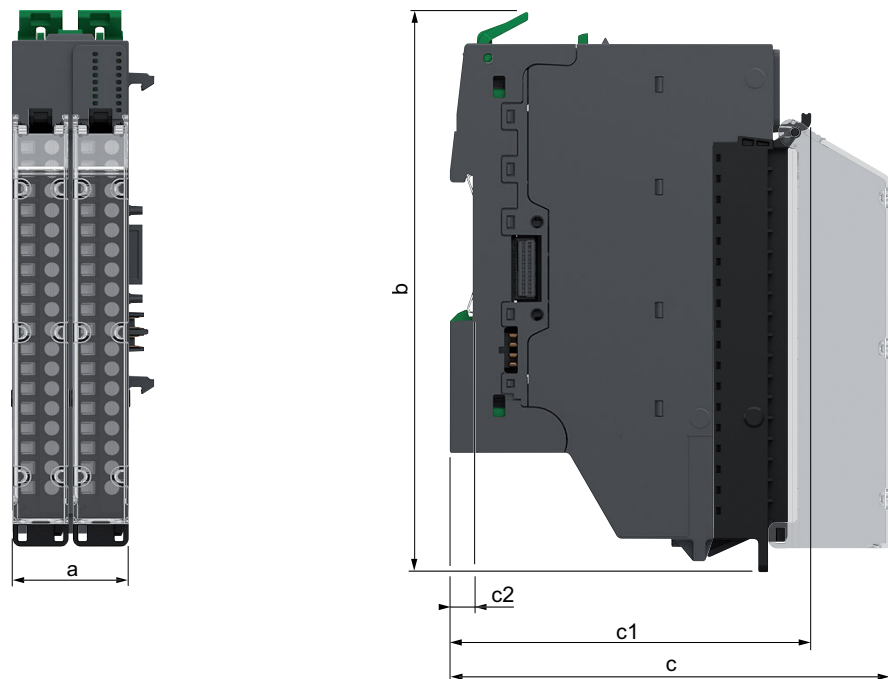

- a:** 30 mm (1.18 in)
- b:** 137.6 mm (5.39 in)
- c:** 107.5 mm (4.21 in)
- c1:** 88.2 mm (3.46 in)
- c2:** 5.6 mm (0.2 in)

Weight

- NTSDDI1602X: 84 g (2.97 oz)
- NTSDDI1602XK: 130 g (4.59 oz)
- NTSDDI1602XH: 85 g (3 oz)
- NTSDDI1602XHK: 133 g (4.7 oz)

General Characteristics

The following table describes the general characteristics of the NTSDDI1602X/
NTSDDI1602XH input modules:

Characteristics		Value
Input compatibility		Type 3 according to IEC 61131-2
Field power supplied voltage requirements		<ul style="list-style-type: none"> • From the 24 Vdc field power • From a common distribution module • From an external power supply (0 Vdc connected to the field power 0 Vdc)
Power supplied voltage range		20.4...28.8 Vdc
Bus current consumption		40.8 mA
Field current consumption for sensors, per module		517.3 mA
Power dissipation		2.52 W
Maximum cable length	Shielded	600 m (1,968 ft)
	Unshielded	600 m (1,968 ft)
Isolation voltage	Between channels	No
	Between groups	No
	Between channel and bus	1,500 Vac
	Between channel and functional earth ground	1,500 Vac
Hot swap supported		Yes
Operating ambient temperature derating		No derating

Input Characteristics

The table below describes the input characteristics of the NTSDDI1602X/
NTSDDI1602XH input modules:

Characteristics		Value
Input wiring mode		1-/2-/3-wire
Nominal input current		2.5 mA
Input voltage	Logic state 1	11...30 Vdc
	Logic state 0	< 5 Vdc
Input current	Logic state 1	2 mA minimum
	Logic state 0	1.5 mA maximum
Input impedance		9.6 kΩ
Response time on input	Logic state 1 to logic state 0	< 60 μs
	Logic state 0 to logic state 1	< 90 μs
Input filter time	Hardware	< 100 μs
	Software	Configurable
Paralleling of inputs		Yes
Input protection		Over voltage protection
Input diagnostic		No
Monitoring functions		Power supply monitoring (under voltage, power absent)

NTSDDI1602X/NTSDDI1602XH Wiring

Wiring Rules

For more information on the wiring, refer to Modicon Edge I/O - System Planning and Installation Guide.

Wiring Diagrams

This module allows the use of an external power supply to energize the sensors.

⚠ WARNING

UNINTENDED EQUIPMENT OPERATION

Use the sensor and actuator power supply only for supplying power to sensors or actuators connected to the module.

Failure to follow these instructions can result in death, serious injury, or equipment damage.

This module can support one 3-wire sensor per group of 4 channels (up to 4 3-wire sensors).

Wiring

The following figure illustrates an example of 2-/3-wire connection inputs with the internal powers supply or common module NTSPCM1600H:

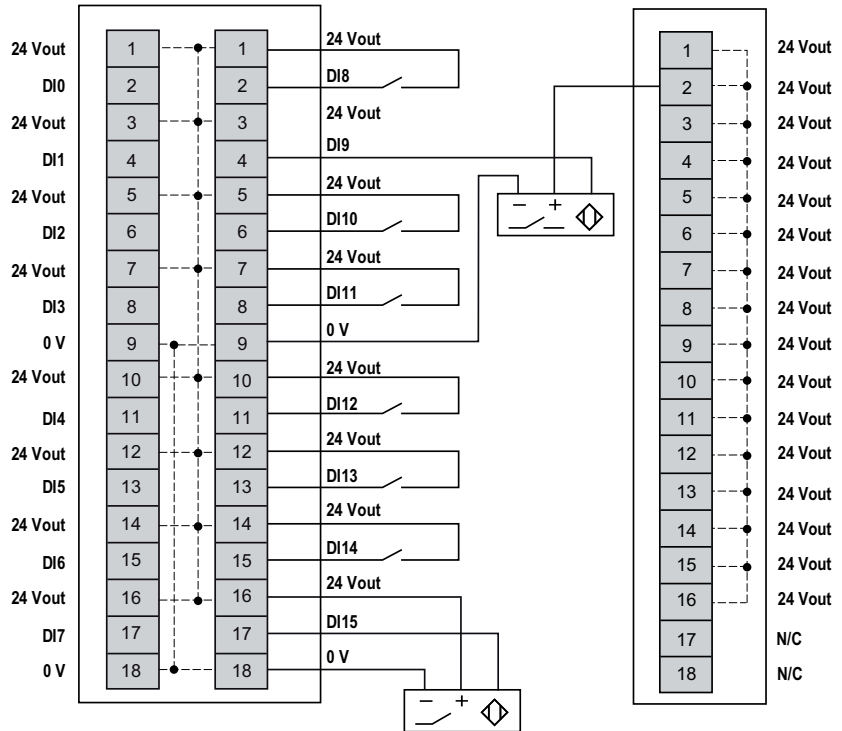

N/C: No connection

⚠ WARNING

UNINTENDED EQUIPMENT OPERATION

Do not connect wires to unused terminals and/or terminals indicated as "No Connection (N/C)".

Failure to follow these instructions can result in death, serious injury, or equipment damage.

The following figure illustrates an example of 2-wire connection inputs with an external power supply:

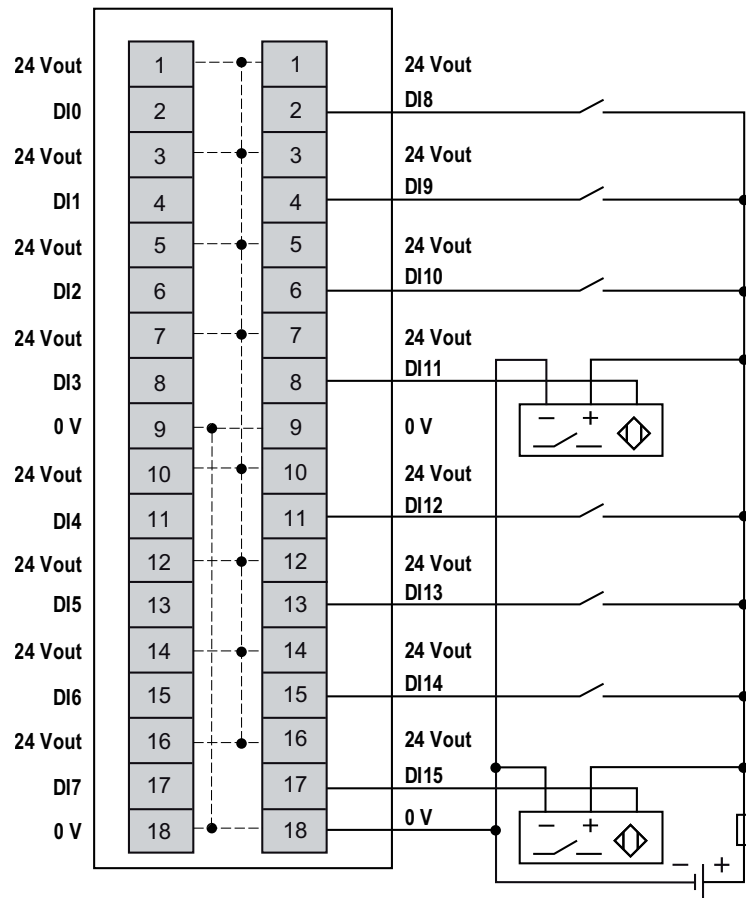

External Fuse: Type F, 0.5 A, 24 Vdc is mandatory and must be chosen in compliance with IEC60269 standard.

NTSDDI1602X/NTSDDI1602XH Parameters

Parameters Description

Configurable Parameters

The following table presents the configurable parameters for the NTSDDI1602X/NTSDDI1602XH modules:

Displayed Name <i>Parameter Name</i>	Value	Data type	Description
Device Mode <i>DeviceMode</i>	0: Normal* 1: Optional 2: Virtual reserved	ENUM	Allows you to select the device mode: <ul style="list-style-type: none"> • Normal: The module is part of the software configuration and is physically connected in the cluster. • Optional: The module is part of the software configuration. A dummy module or the configured module must be physically installed in the cluster. Whether either module is present does not cause a configuration error to be detected. • Virtual reserved: The module is part of the software configuration. A dummy module must be physically installed in the cluster. If the virtual module is physically installed in the cluster, a configuration error is detected.
Diag Enable Sensor Power Supply <i>DiagEnableSensorPower-Supply⁽¹⁾</i>	FALSE TRUE*	BOOL	Enables or disables the sensor power supply diagnostics.
* Parameter default value ⁽¹⁾ Online modification is allowed.			

The following table presents the configurable parameters for the channels of the NTSDDI1602X/NTSDDI1602XH modules:

Displayed Name <i>Parameter Name</i>	Value	Data type	Description
Channel Enabled <i>ChannelEnable⁽¹⁾</i>	TRUE* FALSE	BOOL	Determines whether a channel is enabled or disabled.
Latch <i>Latch⁽¹⁾</i>	0: No* 1: Rising Edge - Automatic Acknowledge 2: Falling Edge - Automatic Acknowledge 3: Both Edges - Automatic Acknowledge 4: Rising Edge - Manual Acknowledge 5: Falling Edge - Manual Acknowledge 6: Both Edges - Manual Acknowledge	ENUM	Allows incoming pulses with a pulse width shorter than the network interface module scan time to be captured and recorded. For more information, refer to Input Latch , page 286.
Filter <i>Filter⁽¹⁾</i>	Range: 0...20 ms Interval: 0.1 ms 1.0 ms*	FLOAT	Allows reducing the effect of bounce on the input. Changes to the signal are only detected if the pulse width of the input signal is longer than the filter time.
* Parameter default value ⁽¹⁾ Online modification is allowed.			

Implicit Data

The following table presents the input implicit data for the module:

Parameter Name	Value	Data type Size in bytes R/W	Description
GCS	0...255	BYTE 1 R/-	Group Cyclic Status Bit 0: Data quality Bit 1: General module status Bit 2: I/O status Bit 3: N/A Bit 4: N/A Bit 5: Advisory status Bit 6: N/A Bit 7: Data freshness NOTE: For more information, refer to Modicon Edge I/O - Diagnostic Data - User Guide.
ChannelHealth0_7 ⁽¹⁾	0...255	BYTE 1 R/-	Bit 0...7 = Status of channel 0...7 <ul style="list-style-type: none"> Bit = FALSE: Channel is invalid or not present. Bit = TRUE: Channel is valid or disabled.
ChannelHealth8_15 ⁽¹⁾	0...255	BYTE 1 R/-	Bit 0...7 = Status of channel 8...15 <ul style="list-style-type: none"> Bit = 0: Channel is invalid Bit = 1: Channel is valid
IValue0_7	0...255	BYTE 1 R/-	Value of the input channels (Bit field). Bit 0...7 = Value of channel 0...7 NOTE: Unused bits are reserved.
IValue8_15	0...255	BYTE 1 R/-	Value of the input channels (Bit field). Bit 0...7 = Value of channel 8...15 NOTE: Unused bits are reserved.

⁽¹⁾ This parameter is not part of the implicit data if the optimized I/O profile is selected.

The following table presents the output implicit data for the module:

Parameter Name	Value	Data type Size in bytes R/W	Description
LatchAck0_7	0...255	BYTE 1 R/W	At rising edge, resets the latch value of the input on the channel 0...7. Bit 0...7 = Value of channel 0...7
LatchAck8_15	0...255	BYTE 1 R/W	At rising edge, resets the latch value of the input on the channel 8...15. Bit 0...7 = Value of channel 8...15

Explicit Data

The following table presents the explicit data for the channels of the module:

Parameter Name	Value	Data type Size in bytes R/W	Description
<i>ChannelFault</i>	0...255	BYTE R/-	Provides the following detected error on the channel: Bit 3: Sensor power supply error detected Bit 4: Internal power supply error detected NOTE: Unused bits are reserved.
<i>IValue</i>	TRUE = Channel is in logic state 1 FALSE = Channel is in logic state 0	BOOL R/-	Value of the input channel.
<i>LatchAck</i>	–	BOOL R/W	At rising edge, resets the latch value of the input on the channel.

NTSDDI1642 Discrete Input Module, 16 Inputs, 24 Vdc, Source, 1-wire

What's in This Chapter

NTSDDI1642 Presentation.....	86
NTSDDI1642 Characteristics	90
NTSDDI1642 Wiring	93
NTSDDI1642 Parameters	95

NTSDDI1642 Presentation

Main Characteristics

The following table describes the main characteristics of the NTSDDI1642 input module:

Main Characteristics	Value
Product or component type	Discrete DC input module
Number of Input channels	16
Groups of channels	1 group of 16 channels
Nominal input voltage	24 Vdc
Input logic type	Source
Operating mode	Synchronous and isochronous

Purchasing Information

The following figure shows the elements of the Modicon Edge I/O NTS NTSDDI1642 input module:

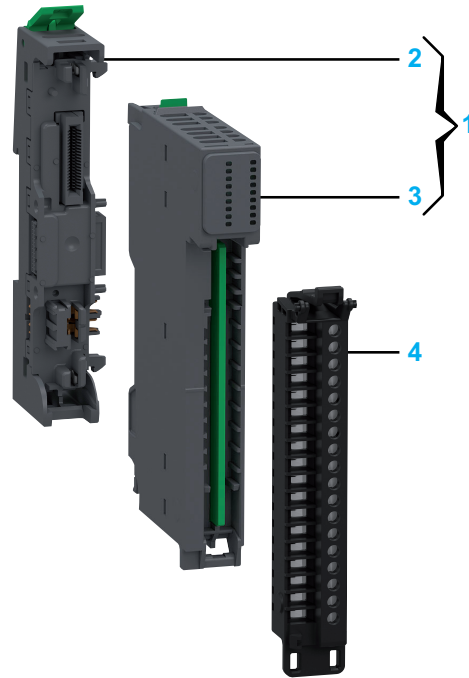

Number	Reference	Description
1	NTSDDI1642K	Base + Module (kit) NOTE: The module and its corresponding base can be purchased as a kit.
2	NTSXBA0100H	Spare Base, 1 Slot, for Input/Output Common or Expert Module, Hardened
3	NTSDDI1642	Discrete Input Module, 16 Inputs, 24 Vdc, Source, 1-wire
4	NTSXTB18200H NTSXTB18201H NTSXTB18000H NTSXTB18001H	Spring Terminal Block, 18 Points, 3.81 mm Pitch, Without Cover, use on Low Height Module, Hardened Spring Terminal Block, 18 Points, 3.81 mm Pitch, With Cover, use on Low Height Module, Hardened Screw Terminal Block, 18 Points, 3.81 mm Pitch, Without Cover, use on Low Height Module, Hardened Screw Terminal Block, 18 Points, 3.81 mm Pitch, With Cover, use on Low Height Module, Hardened NOTE: The terminal blocks are purchased separately.

NOTE: For more information on accessories and spare parts, refer to Modicon Edge I/O - System Planning and Installation Guide.

Physical Description

The following figure presents the elements of the module:

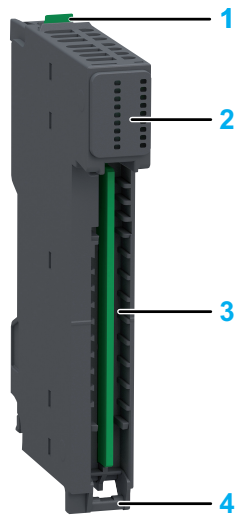

- 1: Release button for disengaging the module from the base
- 2: Status LEDs
- 3: Slot for the terminal block
- 4: Hinge for the terminal block installation

Status LEDs

The following figure presents the NTSDDI1642 status LEDs:



The following table describes the status of LEDs:

R (Green)	E (Red)	IN0...15 (Green)	Description
Initialization and non-operational states			
OFF	OFF	OFF	Indicates that the module is not energized.
OFF	Fast Flash	-	Indicates that the module has detected a system error.
Regular Flash	OFF	-	Indicates that the firmware is being updated.
Regular Flash	ON	-	Indicates that a module mismatch is detected.
Single Flash	OFF	-	Indicates that the module is energized and not configured.
Operational state			
ON	OFF	-	Indicates that the module is energized, configured and operational.
ON	-	ON	Indicates that the corresponding input channel is activated.
ON	-	OFF	Indicates that the corresponding input channel is deactivated.
ON	Regular Flash	OFF	Indicates one of the following: <ul style="list-style-type: none"> • 24 Vdc field power error detection. • Sensor power supply error detection.

The following graphic depicts the system status of LEDs during module operation:

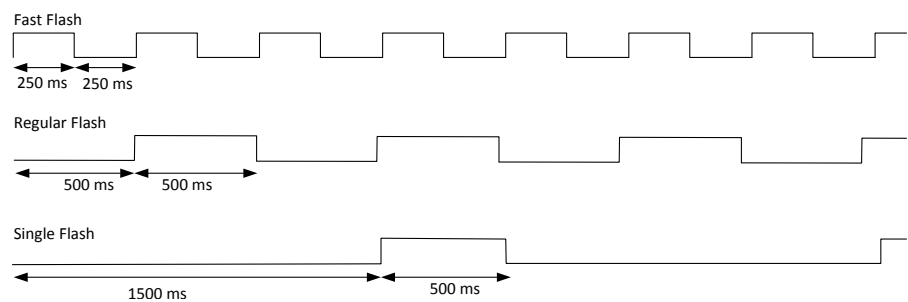

NTSDDI1642 Characteristics

Overview

This section provides a general description of the characteristics of the module.

⚠ WARNING

UNINTENDED EQUIPMENT OPERATION

Do not exceed any of the rated values specified in the environmental and electrical characteristics tables.

Failure to follow these instructions can result in death, serious injury, or equipment damage.

For more information on environmental characteristics, refer to Modicon Edge I/O - System Planning and Installation Guide.

Dimensions

The following figure presents the external dimensions of the assembled module:

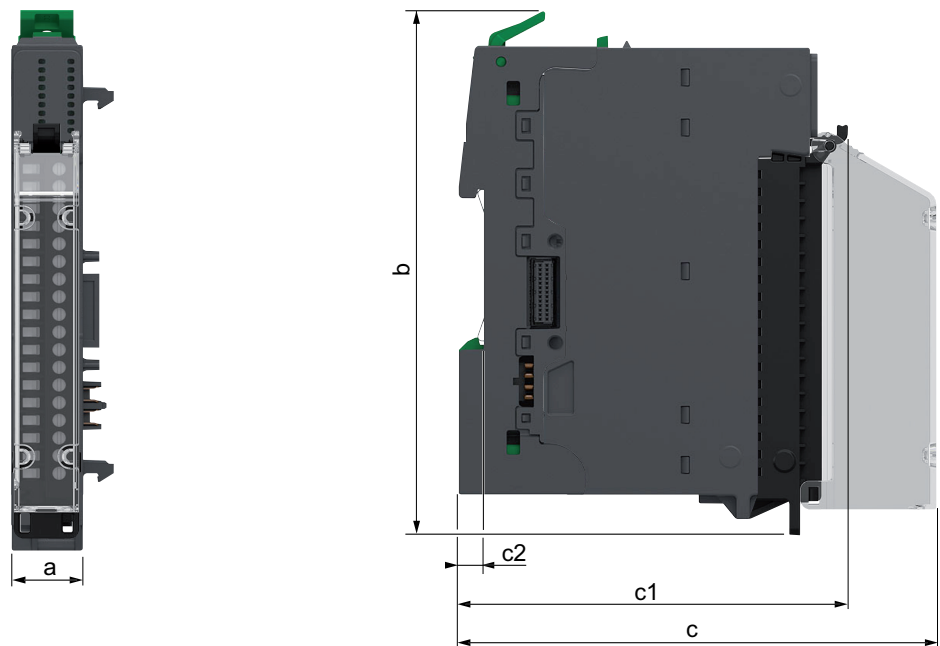

- a:** 15 mm (0.59 in)
- b:** 116.6 mm (4.57 in)
- c:** 107.5 mm (4.21 in)
- c1:** 88.2 mm (3.46 in)
- c2:** 5.6 mm (0.2 in)

Weight

- NTSDDI1642: 48 g (1.69 oz)
- NTSDDI1642K: 73 g (2.57 oz)

General Characteristics

The following table describes the general characteristics of the NTSDDI1642 input module:

Characteristics		Value	
Input compatibility		Type 3 according to IEC 61131-2	
Field power supplied voltage requirements		<ul style="list-style-type: none"> • From the 24 Vdc field power • From an external power supply (24 Vdc connected to the field power 24 Vdc) 	
Power supplied voltage range		20.4...28.8 Vdc	
Bus current consumption		43.2 mA	
Field current consumption for sensors, per module		2.9 mA	
Power dissipation		2.48 W	
Maximum cable length	Shielded	1,000 m (3,280 ft)	
	Unshielded	600 m (1,968 ft)	
Isolation voltage	Between channels	No	
	Between groups	No	
	Between channel and bus	1,500 Vac	
	Between channel and functional earth ground	1,500 Vac	
Hot swap supported		Yes	
Operating ambient temperature derating	Nominal voltage 24 Vdc	Correct mounting position ⁽¹⁾	16 channels: up to 55 °C (131 °F) 12 channels: 55...60 °C (131...140 °F)
		Accepted mounting position ⁽¹⁾	16 channels: up to 50 °C (122 °F) 12 channels: 50...55 °C (122...131 °F)
	Nominal voltage 28.8 Vdc	Correct mounting position ⁽¹⁾	16 channels: up to 50 °C (122 °F) 12 channels: 50...55 °C (122...131 °F) 8 channels: 55...60 °C (131... 140 °F)
		Accepted mounting position ⁽¹⁾	16 channels: up to 45 °C (113 °F) 12 channels: 45...50 °C (122 °F) 8 channels: 50...55 °C (122...131 °F)
⁽¹⁾ For information about mounting positions, refer to Modicon Edge I/O - System Planning and Installation Guide.			

Input Characteristics

The table below describes the input characteristics of the NTSDDI1642 input module:

Characteristics		Value
Input wiring mode		1-wire
Nominal input current		2.5 mA
Input voltage	Logic state 1	11...30 Vdc
	Logic state 0	< 5 Vdc
Input current	Logic state 1	2 mA minimum
	Logic state 0	1.5 mA maximum
Input impedance		9.6 k Ω
Response time on input	Logic state 1 to logic state 0	< 125 μ s
	Logic state 0 to logic state 1	< 125 μ s
Input filter time	Hardware	< 100 μ s
	Software	Configurable
Paralleling of inputs		Yes
Input protection		Over voltage protection
Input diagnostic		No
Monitoring functions		Power supply monitoring (under voltage, power absent)

NTSDDI1642 Wiring

Wiring Rules

For more information on the wiring, refer to Modicon Edge I/O - System Planning and Installation Guide.

Wiring Diagrams

This module allows the use of an external power supply to energize the sensors.

⚠ WARNING
UNINTENDED EQUIPMENT OPERATION
Use the sensor and actuator power supply only for supplying power to sensors or actuators connected to the module.
Failure to follow these instructions can result in death, serious injury, or equipment damage.

The following figure illustrates an example of 1-wire connection inputs with a common module NTSPCM1600H:

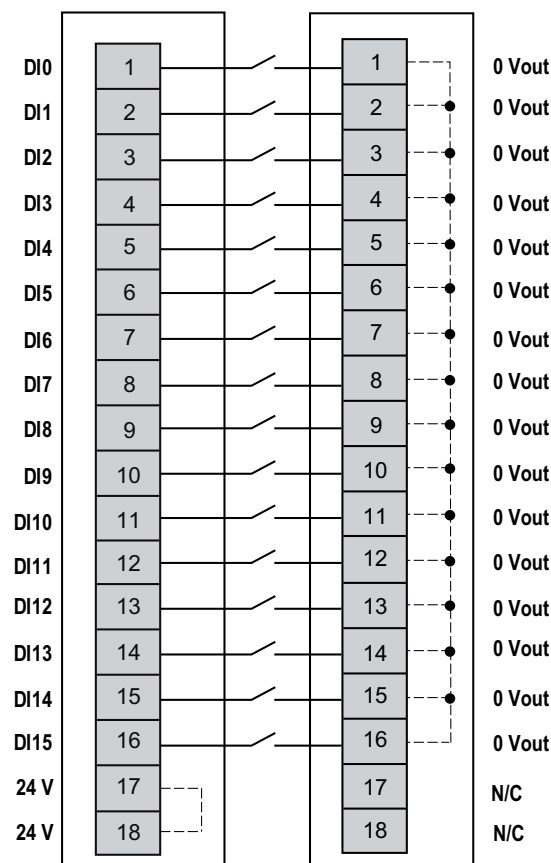

N/C: No Connection

⚠ WARNING**UNINTENDED EQUIPMENT OPERATION**

Do not connect wires to unused terminals and/or terminals indicated as "No Connection (N/C)".

Failure to follow these instructions can result in death, serious injury, or equipment damage.

The following figure illustrates an example of 1-wire connection inputs with an external power supply:

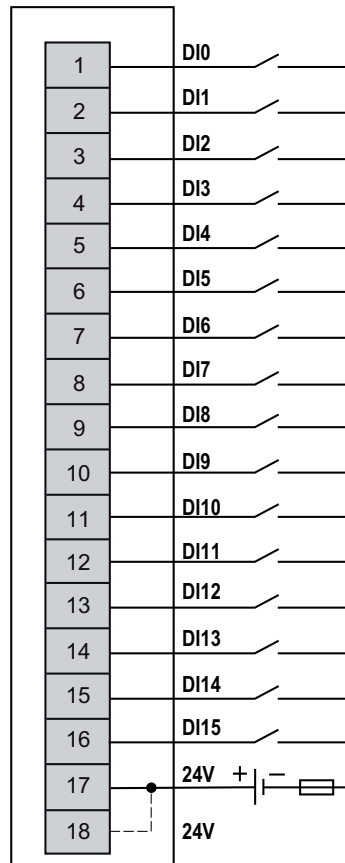

External Fuse: Type F, 0.5 A, 24 Vdc is mandatory and must be chosen in compliance with IEC60269 standard.

NTSDDI1642 Parameters

Parameters Description

Configurable Parameters

The following table presents the configurable parameters for the NTSDDI1642 module:

Displayed Name <i>Parameter Name</i>	Value	Data type	Description
Device Mode <i>DeviceMode</i>	0: Normal* 1: Optional 2: Virtual reserved	ENUM	Allows you to select the device mode: <ul style="list-style-type: none"> • Normal: The module is part of the software configuration and is physically connected in the cluster. • Optional: The module is part of the software configuration. A dummy module or the configured module must be physically installed in the cluster. Whether either module is present does not cause a configuration error to be detected. • Virtual reserved: The module is part of the software configuration. A dummy module must be physically installed in the cluster. If the virtual module is physically installed in the cluster, a configuration error is detected.
Diag Enable Sensor Power Supply <i>DiagEnableSensorPower-Supply⁽¹⁾</i>	FALSE TRUE*	BOOL	Enables or disables the sensor power supply diagnostics.
* Parameter default value ⁽¹⁾ Online modification is allowed.			

The following table presents the configurable parameters for the channels of the NTSDDI1642 module:

Displayed Name <i>Parameter Name</i>	Value	Data type	Description
Channel Enabled <i>ChannelEnable⁽¹⁾</i>	TRUE* FALSE	BOOL	Determines whether a channel is enabled or disabled.
Latch <i>Latch⁽¹⁾</i>	0: No* 1: Rising Edge - Automatic Acknowledge 2: Falling Edge - Automatic Acknowledge 3: Both Edges - Automatic Acknowledge 4: Rising Edge - Manual Acknowledge 5: Falling Edge - Manual Acknowledge 6: Both Edges - Manual Acknowledge	ENUM	Allows incoming pulses with a pulse width shorter than the network interface module scan time to be captured and recorded. For more information, refer to Input Latch , page 286.
Filter <i>Filter⁽¹⁾</i>	Range: 0...20 ms Interval: 0.1 ms 1.0 ms*	FLOAT	Allows reducing the effect of bounce on the input. Changes to the signal are only detected if the pulse width of the input signal is longer than the filter time.
* Parameter default value ⁽¹⁾ Online modification is allowed.			

Implicit Data

The following table presents the input implicit data for the module:

Parameter Name	Value	Data type Size in bytes R/W	Description
GCS	0...255	BYTE 1 R/-	Group Cyclic Status Bit 0: Data quality Bit 1: General module status Bit 2: I/O status Bit 3: N/A Bit 4: N/A Bit 5: Advisory status Bit 6: N/A Bit 7: Data freshness NOTE: For more information, refer to Modicon Edge I/O - Diagnostic Data - User Guide.
ChannelHealth0_7 ⁽¹⁾	0...255	BYTE 1 R/-	Bit 0...7 = Status of channel 0...7 • Bit = FALSE: Channel is invalid or not present. • Bit = TRUE: Channel is valid or disabled.
ChannelHealth8_15 ⁽¹⁾	0...255	BYTE 1 R/-	Bit 0...7 = Status of channel 8...15 • Bit = 0: Channel is invalid • Bit = 1: Channel is valid
IValue0_7	0...255	BYTE 1 R/-	Value of the input channels (Bit field). Bit 0...7 = Value of channel 0...7 NOTE: Unused bits are reserved.
IValue8_15	0...255	BYTE 1 R/-	Value of the input channels (Bit field). Bit 0...7 = Value of channel 8...15 NOTE: Unused bits are reserved.

⁽¹⁾ This parameter is not part of the implicit data if the optimized I/O profile is selected.

The following table presents the output implicit data for the module:

Parameter Name	Value	Data type Size in bytes R/W	Description
LatchAck0_7	–	BYTE 1 R/W	At rising edge, resets the latch value of the input on the channel 0...7. Bit 0...7 = Value of channel 0...7
LatchAck8_15	–	BYTE 1 R/W	At rising edge, resets the latch value of the input on the channel 8...15. Bit 0...7 = Value of channel 8...15

Explicit Data

The following table presents the explicit data for the channels of the module:

Parameter Name	Value	Data type Size in bytes R/W	Description
<i>ChannelFault</i>	0...255	BYTE R/-	Provides the following detected error on the channel: Bit 3: Sensor power supply error detected Bit 4: Internal power supply error detected NOTE: Unused bits are reserved.
<i>IValue</i>	TRUE = Channel is in logic state 1 FALSE = Channel is in logic state 0	BOOL R/-	Value of the input channel.
<i>LatchAck</i>	–	BOOL R/W	At rising edge, resets the latch value of the input on the channel.

NTSDAI0215H Discrete Input Module, 2 Isolated Inputs, 100...240 Vac, 1-/2-/3-wire, Hardened

What's in This Chapter

NTSDAI0215H Presentation	98
NTSDAI0215H Characteristics	102
NTSDAI0215H Wiring	105
NTSDAI0215H Parameters	108

NTSDAI0215H Presentation

Main Characteristics

The following table describes the main characteristics of the NTSDAI0215H input modules:

Main Characteristics	Value
Product or component type	Discrete AC input module
Number of input channels	2
Groups of input channels	2 groups of 1 channel
Nominal input voltage	100...240 Vac
Input logic type	-
Operating mode	Asynchronous

Purchasing Information

The following figure shows the elements of the Modicon Edge I/O NTS NTSDAI0215H input module:

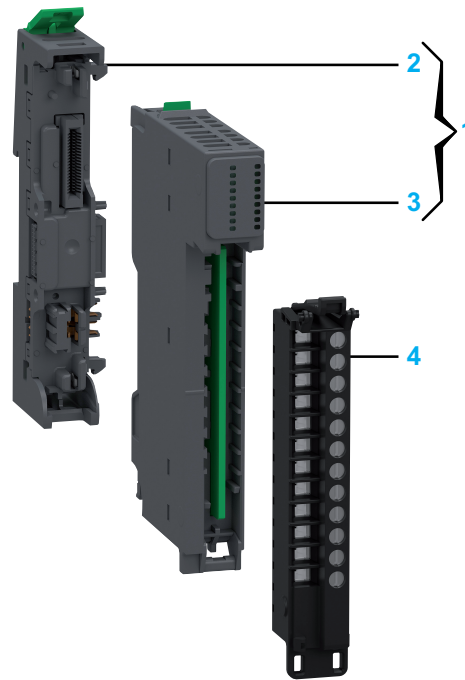

Number	Reference	Description
1	NTSDAI0215HK	Base + Module (kit) NOTE: The module and its corresponding base can be purchased as a kit.
2	NTSXBA0100H	Spare Base, 1 Slot, for Input/Output Common or Expert Module, Hardened
3	NTSDAI0215H	Discrete Input Module, 2 Isolated Inputs, 100...240 Vac, 1-/2-/3-wire, Hardened
4	NTSXTB12211H NTSXTB12011H NTSXTB12210H NTSXTB12010H	Spring Terminal Block, 12 Points, 5 mm Pitch, With Cover, AC, use on Low Height Module, Hardened Screw Terminal Block, 12 Points, 5 mm Pitch, With Cover, AC, use on Low Height Module, Hardened Spring Terminal Block, 12 Points, 5 mm Pitch, Without Cover, AC, use on Low Height Module, Hardened Screw Terminal Block, 12 Points, 5 mm Pitch, Without Cover, AC, use on Low Height Module, Hardened NOTE: The terminal blocks are purchased separately.

NOTE: For more information on accessories and spare parts, refer to Modicon Edge I/O - System Planning and Installation Guide.

Physical Description

The following figure presents the elements of the module:

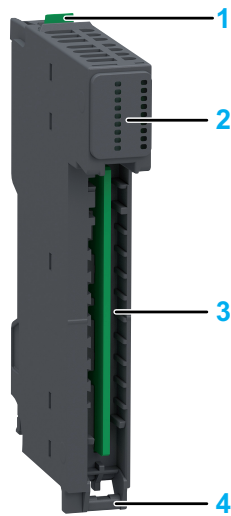

- 1: Release button for disengaging the module from the base
- 2: Status LEDs
- 3: Slot for the terminal block
- 4: Hinge for the terminal block installation

Status LEDs

The following figure presents the NTSDAI0215H status LEDs:

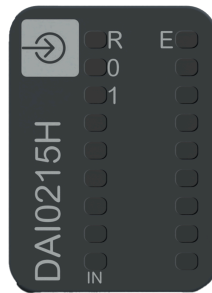

The following table describes the status of LEDs:

R (Green)	E (Red)	IN0...1 (Green)	Description
Initialization and non-operational states			
OFF	OFF	OFF	Indicates that the module is not energized.
OFF	Fast Flash	-	Indicates that the module has detected a system error.
Regular Flash	OFF	-	Indicates that the firmware is being updated.
Regular Flash	ON	-	Indicates that a module mismatch is detected.
Single Flash	OFF	-	Indicates that the module is energized and not configured.
Operational state			
ON	OFF	-	Indicates that the module is energized, configured and operational.
ON	-	ON	Indicates that the corresponding input channel is activated.
ON	-	OFF	Indicates that the corresponding input channel is deactivated.
ON	Regular Flash	OFF	Indicates one of the following: <ul style="list-style-type: none"> • 24 Vdc field power error detection. • Sensor power supply error detection.
ON	Regular Flash	Regular Flash	Indicates that a broken wire error is detected.

The following graphic depicts the system status of LEDs during module operation:

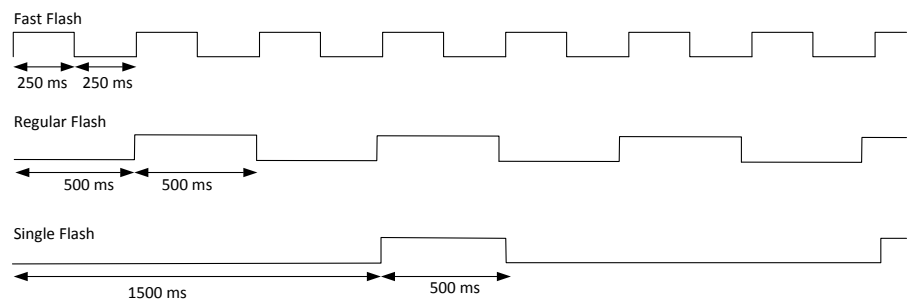

NTSDAI0215H Characteristics

Overview

This section provides a general description of the characteristics of the module.

⚠ WARNING

UNINTENDED EQUIPMENT OPERATION

Do not exceed any of the rated values specified in the environmental and electrical characteristics tables.

Failure to follow these instructions can result in death, serious injury, or equipment damage.

For more information on environmental characteristics, refer to Modicon Edge I/O - System Planning and Installation Guide.

Dimensions

The following figure presents the external dimensions of the assembled module:

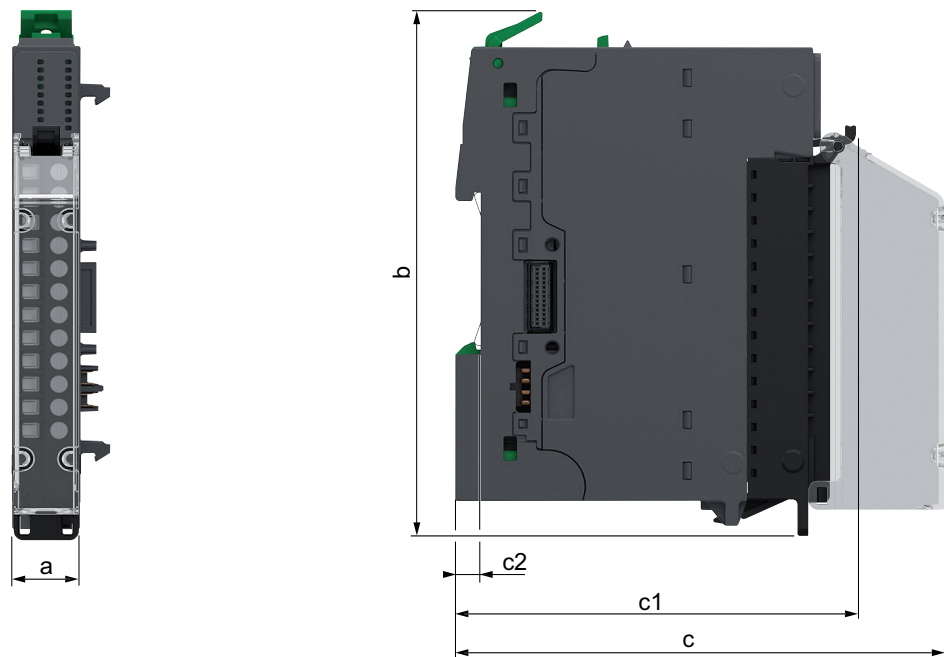

- a: 15 mm (0.59 in)
- b: 116.6 mm (4.57 in)
- c: 107.5 mm (4.21 in)
- c1: 88.2 mm (3.46 in)
- c2: 5.6 mm (0.2 in)

Weight

- NTSDAI0215H: 48 g (1.69 oz)
- NTSDAI0215HK: 73 g (2.57 oz)

General Characteristics

The following table describes the general characteristics of the NTSDAI0215H input module:

Characteristics		Value
Input compatibility		Type 1 according to IEC 61131-2
Field power supplied voltage requirements		From an external 100..240 Vac power supply
Power supplied voltage range		85...264 Vac (47...63 Hz)
Bus current consumption		26.4 mA
Field current consumption for sensors, per module		0 mA
Power dissipation		1.17 W
Maximum cable length	Shielded	1,000 m (3,280 ft)
	Unshielded	600 m (1,968 ft)
Isolation voltage	Between channels	1,780 Vac
	Between groups	-
	Between channel and bus	3,000 Vac
	Between channel and functional earth ground	3,000 Vac
Hot swap supported		Yes
Operating ambient temperature derating		No derating

Input Characteristics

The table below describes the input characteristics of the NTSDAI0215H input module:

Characteristics		Value
Input wiring mode		1-/2-/3-wire
Nominal input current		<ul style="list-style-type: none"> • 3.7 mA at 120 Vac 50 Hz • 7.1 mA at 230 Vac 50 Hz
Input voltage	Logic state 1	79 Vac
	Logic state 0	40 Vac
Input current	Logic state 1	> 2 mA
	Logic state 0	< 2 mA
Input frequency range		47...63 Hz
Response time on input	Logic state 1 to logic state 0	5.8 ms
	Logic state 0 to logic state 1	5.8 ms to 16.4 ms (+ 5.8 ms delay)
Input filter time	Hardware	5.8...20 ms
	Software	Configurable
Input diagnostic		Broken wire
Monitoring functions		<ul style="list-style-type: none"> • Power supply monitoring (under voltage, power absent), power monitor threshold: <ul style="list-style-type: none"> ◦ Ok > 85 Vac ◦ Error detected < 40 Vac • Broken wire detection on sensor input is possible with an additional resistor (R_{bwd}) in parallel: 220 kΩ, 1 W, 10%. NOTE: Connect the resistor to the sensor connections.

NTSDAI0215H Wiring

Wiring Rules

For more information on the wiring, refer to Modicon Edge I/O - System Planning and Installation Guide.

Wiring Diagrams

Each input channel requires an external 120...230 Vac power supply.

To maintain the isolation between channels, use 2 independent power supplies.

⚠ WARNING

UNINTENDED EQUIPMENT OPERATION

Use the sensor and actuator power supply only for supplying power to sensors or actuators connected to the module.

Failure to follow these instructions can result in death, serious injury, or equipment damage.

The following figure illustrates an example, with isolation between channels, of a 3-wire connection input with power supply monitoring and a 2-wire connection input without power supply monitoring:

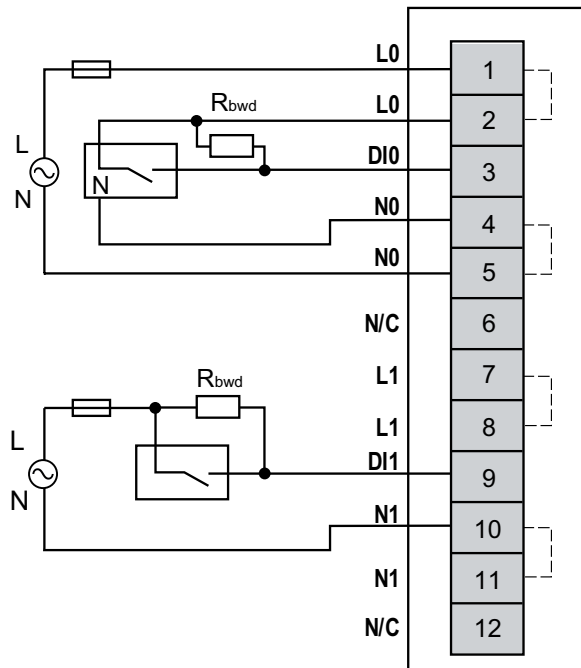

N/C: No Connection

R_{bwd} (required when broken wire detection is enabled): 200 kΩ, 1 W, 10%

External Fuse: Type F, 0.5 A, 230 Vac is mandatory and must be chosen in compliance with IEC60269 standard.

⚠ WARNING

UNINTENDED EQUIPMENT OPERATION

Do not connect wires to unused terminals and/or terminals indicated as “No Connection (N/C)”.

Failure to follow these instructions can result in death, serious injury, or equipment damage.

The following figure illustrates an example, without isolation between channels, of a 2-wire connection input with power supply monitoring and a 1-wire connection input without power supply monitoring:

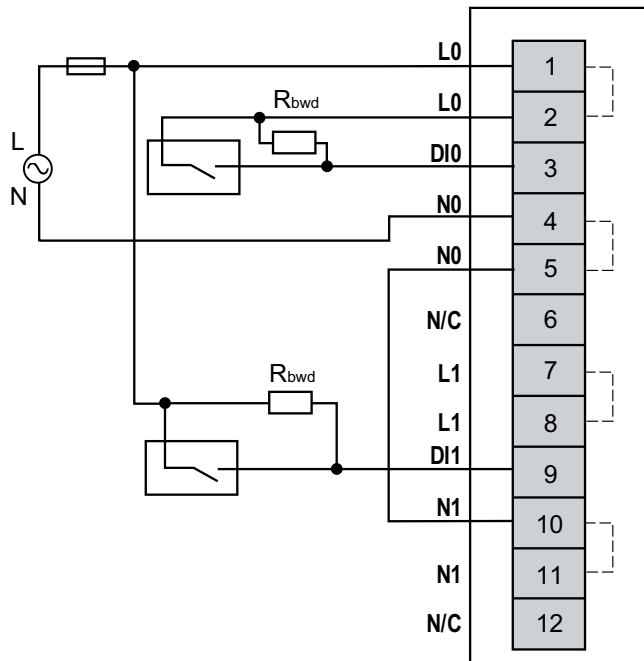

N/C: No Connection

R_{bwd} (required when broken wire detection is enabled): 200 k Ω 1 W, 10%

External Fuse: Type F, 0.5 A, 230 Vac is mandatory and must be chosen in compliance with IEC60269 standard.

⚠ WARNING

UNINTENDED EQUIPMENT OPERATION

Do not connect wires to unused terminals and/or terminals indicated as "No Connection (N/C)".

Failure to follow these instructions can result in death, serious injury, or equipment damage.

NTSDAI0215H Parameters

Parameters Description

Configurable Parameters

The following table presents the configurable parameters for the NTSDAI0215H module:

Displayed Name <i>Parameter Name</i>	Value	Data type	Description
Device Mode <i>DeviceMode</i>	0: Normal* 1: Optional 2: Virtual reserved	ENUM	Allows you to select the device mode: <ul style="list-style-type: none"> Normal: The module is part of the software configuration and is physically connected in the cluster. Optional: The module is part of the software configuration. A dummy module or the configured module must be physically installed in the cluster. Whether either module is present does not cause a configuration error to be detected. Virtual reserved: The module is part of the software configuration. A dummy module must be physically installed in the cluster. If the virtual module is physically installed in the cluster, a configuration error is detected.
Diag Enable Broken Wire <i>DiagEnableBrokenWire⁽¹⁾</i>	FALSE TRUE*	BOOL	Enables or disables the broken wire diagnostics.
Diag Enable External Power Supply <i>DiagEnableExternalPower-Supply⁽¹⁾</i>	FALSE TRUE*	BOOL	Enables or disables the external power supply diagnostics.
* Parameter default value ⁽¹⁾ Online modification is allowed.			

The following table presents the configurable parameters for the channels of the NTSDAI0215H module:

Displayed Name <i>Parameter Name</i>	Value	Data type	Description
Channel Enabled <i>ChannelEnable⁽¹⁾</i>	TRUE* FALSE	BOOL	Determines whether a channel is enabled or disabled.
Filter <i>Filter⁽¹⁾</i>	Range: 5.8...20 ms Interval: 0.1 ms 5.8 ms*	FLOAT	Allows reducing the effect of bounce on the input. Changes to the signal are only detected if the pulse width of the input signal is longer than the filter time.
* Parameter default value ⁽¹⁾ Online modification is allowed.			

Implicit Data

The following table presents the input implicit data for the module:

Parameter Name	Value	Data type Size in bytes R/W	Description
<i>GCS</i>	0...255	BYTE 1 R/-	Group Cyclic Status Bit 0: Data quality Bit 1: General module status Bit 2: I/O status Bit 3: N/A Bit 4: N/A Bit 5: Advisory status Bit 6: N/A Bit 7: Data freshness NOTE: For more information, refer to Modicon Edge I/O - Diagnostic Data - User Guide.
<i>ChannelHealth0_7</i> ⁽¹⁾	0...255	BYTE 1 R/-	Bit 0...7 = Status of channel 0...7 • Bit = FALSE: Channel is invalid or not present. • Bit = TRUE: Channel is valid or disabled.
<i>IValue0_7</i>	0...255	BYTE 1 R/-	Value of the input channels (Bit field). Bit 0...7 = Value of channel 0...7 NOTE: Unused bits are reserved.
⁽¹⁾ This parameter is not part of the implicit data if the optimized I/O profile is selected.			

Explicit Data

The following table presents the explicit data for the channels of the module:

Parameter Name	Value	Data type Size in bytes R/W	Description
<i>ChannelFault</i>	0...255	BYTE R/-	Provides the following detected error on the channel: Bit 0: Broken wire error detected Bit 2: External power supply error detected NOTE: Unused bits are reserved.
<i>IValue</i>	TRUE = Channel is in logic state 1 FALSE = Channel is in logic state 0	BOOL R/-	Value of the input channel.

NTSDAI0403H Discrete Input Module, 4 Inputs, 24 Vac, 48 Vac/Vdc, Sink, 1-/2-/3-wire, Hardened

What's in This Chapter

NTSDAI0403H Presentation	110
NTSDAI0403H Characteristics	114
NTSDAI0403H Wiring Diagram	117
NTSDAI0403H Parameters	119

NTSDAI0403H Presentation

Main Characteristics

The following table describes the main characteristics of the NTSDAI0403H input module :

Main Characteristics	Value
Product or component type	Discrete AC input module
Number of Input channels	4
Groups of channels	1 group of 4 channels
Nominal input voltage	<ul style="list-style-type: none"> • 24/48 Vac +/- 10 % • 48 Vdc +/- 10 %
Input logic type	Sink (DC)
Operating mode	Asynchronous

Purchasing Information

The following figure shows the elements of the Modicon Edge I/O NTS NTSDAI0403H input module:

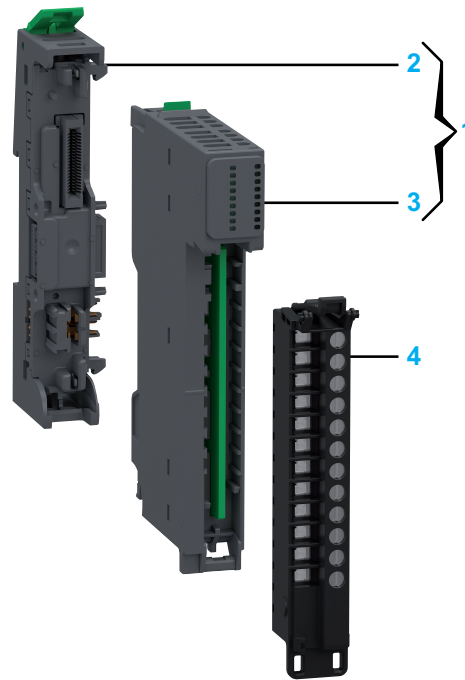

Number	Reference	Description
1	NTSDAI0403HK	Base + Module (kit) NOTE: The module and its corresponding base can be purchased as a kit.
2	NTSXBA0100H	Spare Base, 1 Slot, for Input/Output Common or Expert Module, Hardened
3	NTSDAI0403H	Discrete Input Module, 4 Inputs, 24 Vac, 48 Vac/Vdc, Sink, 1-/2-/3-wire, Hardened
4	NTSXTB12211H NTSXTB12011H NTSXTB12210H NTSXTB12010H	Spring Terminal Block, 12 Points, 5 mm Pitch, With Cover, AC, use on Low Height Module, Hardened Screw Terminal Block, 12 Points, 5 mm Pitch, With Cover, AC, use on Low Height Module, Hardened Spring Terminal Block, 12 Points, 5 mm Pitch, Without Cover, AC, use on Low Height Module, Hardened Screw Terminal Block, 12 Points, 5 mm Pitch, Without Cover, AC, use on Low Height Module, Hardened NOTE: The terminal blocks are purchased separately.

NOTE: For more information on accessories and spare parts, refer to Modicon Edge I/O - System Planning and Installation Guide.

Physical Description

The following figure presents the elements of the module:

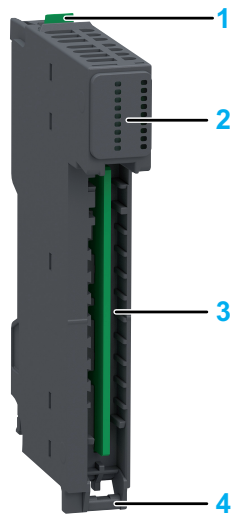

- 1: Release button for disengaging the module from the base
- 2: Status LEDs
- 3: Slot for the terminal block
- 4: Hinge for the terminal block installation

Status LEDs

The following figure presents the NTSDAI0403H status LEDs:



The following table describes the status of LEDs:

R (Green)	E (Red)	IN0...3 (Green)	Description
Initialization and non-operational states			
OFF	OFF	OFF	Indicates that the module is not energized.
OFF	Fast Flash	-	Indicates that the module has detected a system error.
Regular Flash	OFF	-	Indicates that the firmware is being updated.
Regular Flash	ON	-	Indicates that a module mismatch is detected.
Single Flash	OFF	-	Indicates that the module is energized and not configured.
Operational state			
ON	OFF	-	Indicates that the module is energized, configured and operational.
ON	-	ON	Indicates that the corresponding input channel is activated.
ON	-	OFF	Indicates that the corresponding input channel is deactivated.
ON	Regular Flash	OFF	Indicates one of the following: <ul style="list-style-type: none"> • 24 Vdc field power error detection. • Sensor power supply error detection.

The following graphic depicts the system status of LEDs during module operation:

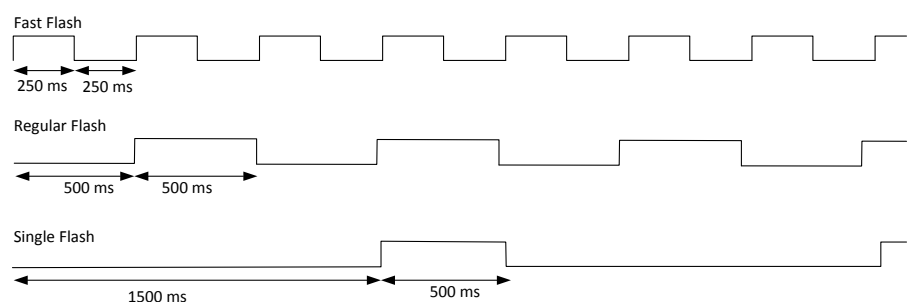

NTSDAI0403H Characteristics

Overview

This section provides a general description of the characteristics of the module.

⚠ WARNING

UNINTENDED EQUIPMENT OPERATION

Do not exceed any of the rated values specified in the environmental and electrical characteristics tables.

Failure to follow these instructions can result in death, serious injury, or equipment damage.

For more information on environmental characteristics, refer to Modicon Edge I/O - System Planning and Installation Guide.

Dimensions

The following figure presents the external dimensions of the assembled module:

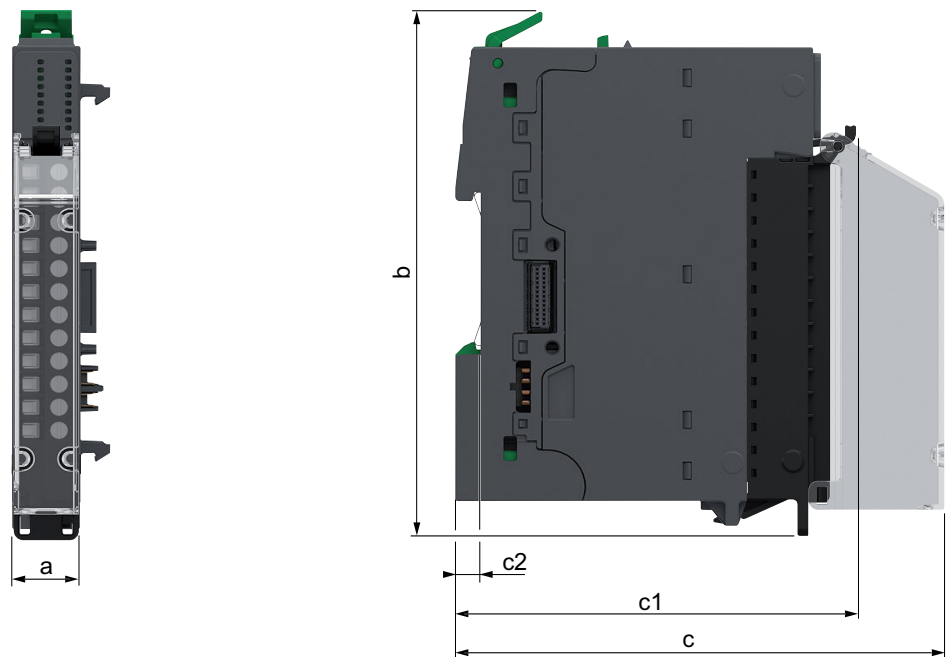

- a: 15 mm (0.59 in)
- b: 116.6 mm (4.57 in)
- c: 107.5 mm (4.21 in)
- c1: 88.2 mm (3.46 in)
- c2: 5.6 mm (0.2 in)

Weight

- NTSDAI0403H: 48 g (1.69 oz)
- NTSDAI0403HK: 73 g (2.57 oz)

General Characteristics

The following table describes the general characteristics of the NTSDAI0403H input module:

Characteristics		Value	
Input compatibility		Type 1 according to IEC 61131-2	
Field power supplied voltage requirements		From an external 24 Vac, 48 Vac or 48 Vdc power supply	
Power supplied voltage range		19.2...55.2 Vac (47...63 Hz) 19.2...60 Vdc	
Bus current consumption		30 mA	
Field current consumption for sensors, per module		0 mA	
Power dissipation		1.51 W	
Maximum cable length	Shielded	1,000 m (3,280 ft)	
	Unshielded	600 m (1,968 ft)	
Isolation voltage	Between channels	-	
	Between groups	-	
	Between channel and bus	3,000 Vac	
	Between channel and functional earth ground	3,000 Vac	
Hot swap supported		Yes	
Operating ambient temperature derating	24 Vac	Correct mounting position ⁽¹⁾	4 channels: up to 70 °C (158 °F)
		Accepted mounting position ⁽¹⁾	4 channels: up to 60 °C (140 °F)
	48 Vdc or 48 Vac	Correct mounting position ⁽¹⁾	4 channels: up to 60 °C (140 °F) 3 channels: 60...65 °C (140...149 °F) 2 channels: 65...70 °C (149...158 °F)
		Accepted mounting position ⁽¹⁾	4 channels: up to 50 °C (122 °F) 3 channels: 50...55 °C (122...131 °F) 2 channels: 55...60 °C (131...140 °F)
⁽¹⁾ For information about mounting positions, refer to Modicon Edge I/O - System Planning and Installation Guide.			

Input Characteristics

The table below describes the input characteristics of the NTSDAI0403H module:

Characteristics		Value
Input wiring mode		1-/2-/3-wire
Nominal input current		2.6 mA
Input voltage	Logic state 1	<ul style="list-style-type: none"> • at 48 Vac: 34 Vac • at 24 Vac: 14 Vac • at 48 Vdc: 34 Vdc
	Logic state 0	<ul style="list-style-type: none"> • at 48 Vac: 10 Vac • at 24 Vac: 5 Vac • at 48 Vdc: 10 Vdc
Input current	Logic state 1	> 2 mA
	Logic state 0	< 2 mA
Input frequency range		47...63 Hz
Response time on input	Logic state 1 to logic state 0	0.5 line cycles maximum
	Logic state 0 to logic state 1	0.5 line cycles maximum
Input filter time	Hardware	9.28 ms
	Software	Configurable (only if Power Supply Type is Vdc)
Input diagnostic		Broken wire
Monitoring functions		<p>Power supply monitoring (under voltage, power absent)</p> <p>Broken wire detection on sensor input is possible with an additional resistor (R_{bwd}) in parallel: 220 kΩ, 1 W, 10%.</p> <p>NOTE: Connect the resistor to the sensor connections.</p>

NTSDAI0403H Wiring Diagram

Wiring Rules

For more information on the wiring, refer to Modicon Edge I/O - System Planning and Installation Guide.

Wiring Diagrams

The input channels of the NTSDAI0403H module require a single power supply 24/48 Vac or 48 Vdc connected to the terminal block.

⚠ WARNING
UNINTENDED EQUIPMENT OPERATION
Use the sensor and actuator power supply only for supplying power to sensors or actuators connected to the module.
Failure to follow these instructions can result in death, serious injury, or equipment damage.

The following figure illustrates an example of 2-/3-wire connection inputs with DC power supply and functional ground:

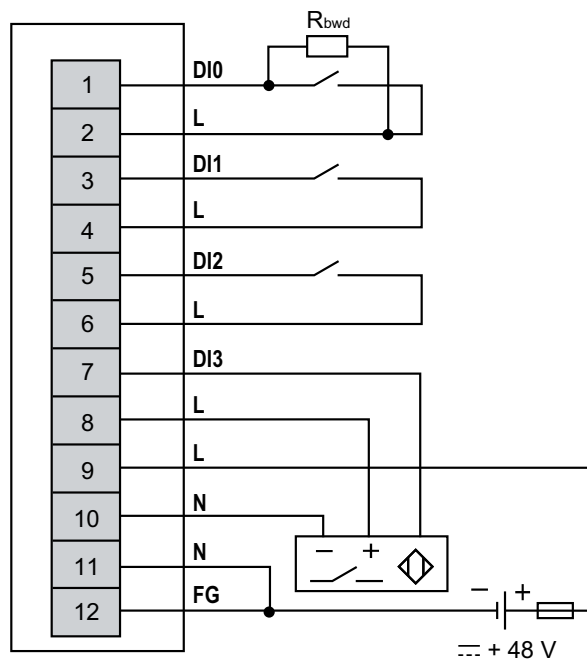

R_{bwd} (required when broken wire detection is enabled): 47 kΩ 1/8 W, 1%
External Fuse: Type F, 0.5 A, 48 Vdc is mandatory and must be chosen in compliance with IEC60269 standard.

The following figure illustrates an example of 2-/3-wire connection inputs with AC power supply and functional ground not connected:

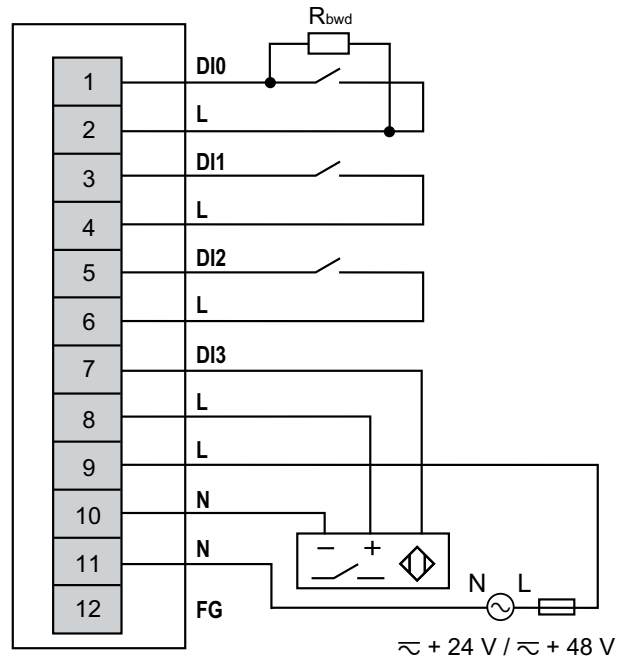

External Fuse: Type F, 0.5 A, 24 / 48 Vac is mandatory and must be chosen in compliance with IEC60269 standard.

R_{bwd} (required when broken wire detection is enabled):

24 Vac: 22k Ω 1/8 W, 1%

48 Vac: 47 k Ω 1/8 W, 1%

NTSDAI0403H Parameters

Parameters Description

Configurable Parameters

The following table presents the configurable parameters for the NTSDAI0403H module:

Displayed Name <i>Parameter Name</i>	Value	Data type	Description
Device Mode <i>DeviceMode</i>	0: Normal * 1: Optional 2: Virtual reserved	ENUM	Allows you to select the device mode: <ul style="list-style-type: none"> • Normal: The module is part of the software configuration and is physically connected in the cluster. • Optional: The module is part of the software configuration. A dummy module or the configured module must be physically installed in the cluster. Whether either module is present does not cause a configuration error to be detected. • Virtual reserved: The module is part of the software configuration. A dummy module must be physically installed in the cluster. If the virtual module is physically installed in the cluster, a configuration error is detected.
Power Supply Type <i>PowerSupplyType</i>	48VDC* 24VAC 48VAC	ENUM	External power supply type
Diag Enable Broken Wire <i>DiagEnableBrokenWire</i> ⁽¹⁾	FALSE TRUE*	BOOL	Enables or disables the broken wire diagnostics.
Diag Enable External Power Supply <i>DiagEnableExternalPower-Supply</i> ⁽¹⁾	FALSE TRUE*	BOOL	Enables or disables the external power supply diagnostics. NOTE: No error will be detected if the module is connected to a 48 Vac external power supply and the Power Supply Type parameter is set to 24VAC .
* Parameter default value			
⁽¹⁾ Online modification is allowed.			

The following table presents the configurable parameters for the channels of the NTSDAI0403H module:

Displayed Name <i>Parameter Name</i>	Value	Data type	Description
Channel Enabled <i>ChannelEnable</i> ⁽¹⁾	TRUE* FALSE	BOOL	Determines whether a channel is enabled or disabled.
Latch <i>Latch</i> ⁽¹⁾	0: No* 1: Rising Edge - Automatic Acknowledge 2: Falling Edge - Automatic Acknowledge 3: Both Edges - Automatic Acknowledge 4: Rising Edge - Manual Acknowledge 5: Falling Edge - Manual Acknowledge 6: Both Edges - Manual Acknowledge	ENUM	Allows incoming pulses with a pulse width shorter than the network interface module scan time to be captured and recorded. For more information, refer to Input Latch, page 286.
Filter <i>Filter</i> ⁽¹⁾	Range: 0...20 ms Interval: 0.1 ms 1.0 ms*	FLOAT	Allows reducing the effect of bounce on the input. Changes to the signal are only detected if the pulse width of the input signal is longer than the filter time.
* Parameter default value (1) Online modification is allowed.			

Implicit Data

The following table presents the input implicit data for the module:

Parameter Name	Value	Data type Size in bytes R/W	Description
<i>GCS</i>	0...255	BYTE 1 R/-	Group Cyclic Status Bit 0: Data quality Bit 1: General module status Bit 2: I/O status Bit 3: N/A Bit 4: N/A Bit 5: Advisory status Bit 6: N/A Bit 7: Data freshness NOTE: For more information, refer to Modicon Edge I/O - Diagnostic Data - User Guide.
<i>ChannelHealth0_7</i> ⁽¹⁾	0...255	BYTE 1 R/-	Bit 0...7 = Status of channel 0...7 <ul style="list-style-type: none"> • Bit = FALSE: Channel is invalid or not present. • Bit = TRUE: Channel is valid or disabled.
<i>IValue0_7</i>	0...255	BYTE 1 R/-	Value of the input channels (Bit field). Bit 0...7 = Value of channel 0...7 NOTE: Unused bits are reserved.
⁽¹⁾ This parameter is not part of the implicit data if the optimized I/O profile is selected.			

The following table presents the output implicit data for the module:

Parameter Name	Value	Data type Size in bytes R/W	Description
<i>LatchAck0_7</i>	–	BYTE 1 R/W	At rising edge, resets the latch value of the input on the channel 0...7. Bit 0...7 = Value of channel 0...7

Explicit Data

The following table presents the explicit data for the channels of the module:

Parameter Name	Value	Data type Size in bytes R/W	Description
<i>ChannelFault</i>	0...255	BYTE R/-	Provides the following detected error on the channel: Bit 0: Broken wire error detected Bit 2: External power supply error detected NOTE: Unused bits are reserved.
<i>IValue</i>	TRUE = Channel is in logic state 1 FALSE = Channel is in logic state 0	BOOL R/-	Value of the input channel.
<i>LatchAck</i>	–	BOOL R/W	At rising edge, resets the latch value of the input on the channel.

NTSDAI0404H Discrete Input Module, 4 Inputs, 100...120 Vac, 1-/2-wire, Hardened

What's in This Chapter

NTSDAI0404H Presentation	123
NTSDAI0404H Characteristics	127
NTSDAI0404H Wiring	130
NTSDAI0404H Parameters	131

NTSDAI0404H Presentation

Main Characteristics

The following table describes the main characteristics of the NTSDAI0404H input module :

Main Characteristics	Value
Product or component type	Discrete AC input module
Number of Input channels	4
Groups of channels	1 group of 4 channels
Nominal input voltage	100...120 Vac
Operating mode	Asynchronous

Purchasing Information

The following figure shows the elements of the Modicon Edge I/O NTS
NTSDAI0404H input module:

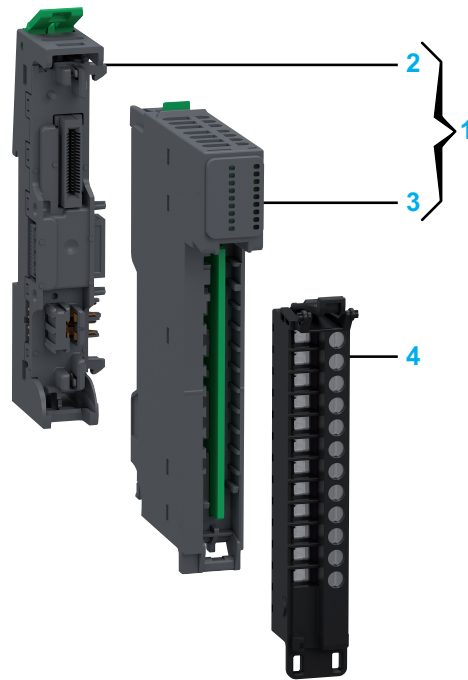

Number	Reference	Description
1	NTSDAI0404HK	Base + Module (kit) NOTE: The module and its corresponding base can be purchased as a kit.
2	NTSXBA0100H	Spare Base, 1 Slot, for Input/Output Common or Expert Module, Hardened
3	NTSDAI0404H	Discrete Input Module, 4 Inputs, 100...120 Vac, 1-/2-wire, Hardened
4	NTSXTB12211H	Spring Terminal Block, 12 Points, 5 mm Pitch, With Cover, AC, use on Low Height Module, Hardened
	NTSXTB12011H	Screw Terminal Block, 12 Points, 5 mm Pitch, With Cover, AC, use on Low Height Module, Hardened
	NTSXTB12210H	Spring Terminal Block, 12 Points, 5 mm Pitch, Without Cover, AC, use on Low Height Module, Hardened
	NTSXTB12010H	Screw Terminal Block, 12 Points, 5 mm Pitch, Without Cover, AC, use on Low Height Module, Hardened
		NOTE: The terminal blocks are purchased separately.

NOTE: For more information on accessories and spare parts, refer to Modicon Edge I/O - System Planning and Installation Guide.

Physical Description

The following figure presents the elements of the module:

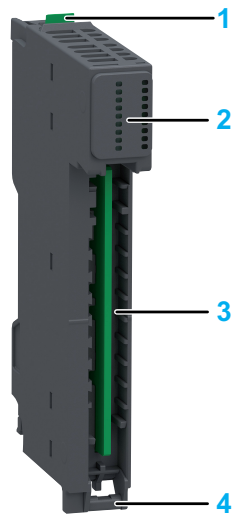

- 1: Release button for disengaging the module from the base
- 2: Status LEDs
- 3: Slot for the terminal block
- 4: Hinge for the terminal block installation

Status LEDs

The following figure presents the NTSDAI0404H status LEDs:



The following table describes the status of LEDs:

R (Green)	E (Red)	IN0...3 (Green)	Description
Initialization and non-operational states			
OFF	OFF	OFF	Indicates that the module is not energized.
OFF	Fast Flash	-	Indicates that the module has detected a system error.
Regular Flash	OFF	-	Indicates that the firmware is being updated.
Regular Flash	ON	-	Indicates that a module mismatch is detected.
Single Flash	OFF	-	Indicates that the module is energized and not configured.
Operational state			
ON	OFF	-	Indicates that the module is energized, configured and operational.
ON	-	ON	Indicates that the corresponding input channel is activated.
ON	-	OFF	Indicates that the corresponding input channel is deactivated.
ON	Regular Flash	OFF	Indicates one of the following: <ul style="list-style-type: none"> • 24 Vdc field power error detection. • Sensor power supply error detection.
ON	Regular Flash	Regular Flash	Indicates that a broken wire error is detected.

The following graphic depicts the system status of LEDs during module operation:

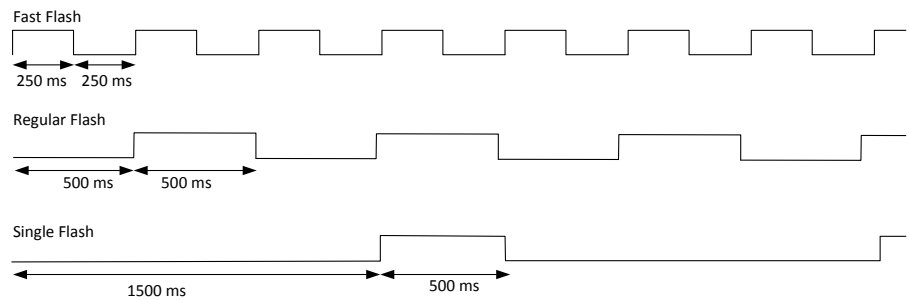

NTSDAI0404H Characteristics

Overview

This section provides a general description of the characteristics of the module.

⚠ WARNING
UNINTENDED EQUIPMENT OPERATION
Do not exceed any of the rated values specified in the environmental and electrical characteristics tables.
Failure to follow these instructions can result in death, serious injury, or equipment damage.

For more information on environmental characteristics, refer to Modicon Edge I/O - System Planning and Installation Guide.

Dimensions

The following figure presents the external dimensions of the assembled module:

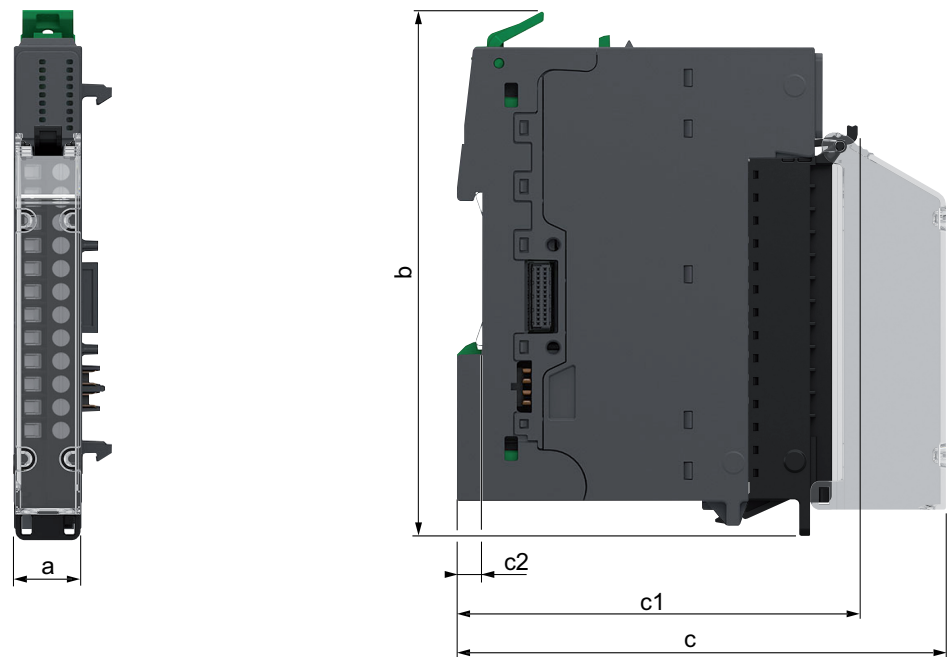

- a:** 15 mm (0.59 in)
- b:** 116.6 mm (4.57 in)
- c:** 107.5 mm (4.21 in)
- c1:** 88.2 mm (3.46 in)
- c2:** 5.6 mm (0.2 in)

Weight

- NTSDAI0404H: 48 g (1.69 oz)
- NTSDAI0404HK: 73 g (2.57 oz)

General Characteristics

The following table describes the general characteristics of the NTSDAI0404H input module:

Characteristics		Value
Input compatibility		Type 1 according to IEC 61131-2
Field power supplied voltage requirements		From an external 100..120 Vac power supply
Power supplied voltage range		85...138 Vac (47...63 Hz)
Bus current consumption		30 mA
Field current consumption for sensors, per module		0 mA
Power dissipation		1.02 W
Maximum cable length	Shielded	1,000 m (3,280 ft)
	Unshielded	600 m (1,968 ft)
Isolation voltage	Between channels	-
	Between groups	-
	Between channel and bus	3,000 Vac
	Between channel and functional earth ground	3,000 Vac
Hot swap supported		Yes
Operating ambient temperature derating		No derating

Input Characteristics

The table below describes the input characteristics of the NTSDAI0404H input module:

Characteristics		Value
Input wiring mode		1-wire, 2-wire
Nominal input current		5.1 mA at 120 Vac 50 Hz
Input voltage	Logic state 1	79 Vac
	Logic state 0	20 Vac
Input current	Logic state 1	> 2 mA
	Logic state 0	< 2 mA
Input frequency range		47...63 Hz
Response time on input	Logic state 1 to logic state 0	5.8 ms
	Logic state 0 to logic state 1	5.8 ms to 16.4 ms
Input filter time	Hardware	5.8...20 ms
	Software	Configurable
Input diagnostic		Broken wire
Monitoring functions		Power supply monitoring (under voltage, power absent) Broken wire detection on sensor input is possible with an additional resistor (Rbwd) in parallel: 220 kΩ, 1 W, 10%. NOTE: Connect the resistor to the sensor connections.

NTSDAI0404H Wiring

Wiring Rules

For more information on the wiring, refer to Modicon Edge I/O - System Planning and Installation Guide.

Wiring Diagram

The input channels of the NTSDAI0404H module require one shared external 120 Vac power supply connected to the terminal block.

⚠ WARNING

UNINTENDED EQUIPMENT OPERATION

Use the sensor and actuator power supply only for supplying power to sensors or actuators connected to the module.

Failure to follow these instructions can result in death, serious injury, or equipment damage.

The following figure illustrates an example of 1-/2-wire connection inputs with a shared external power supply:

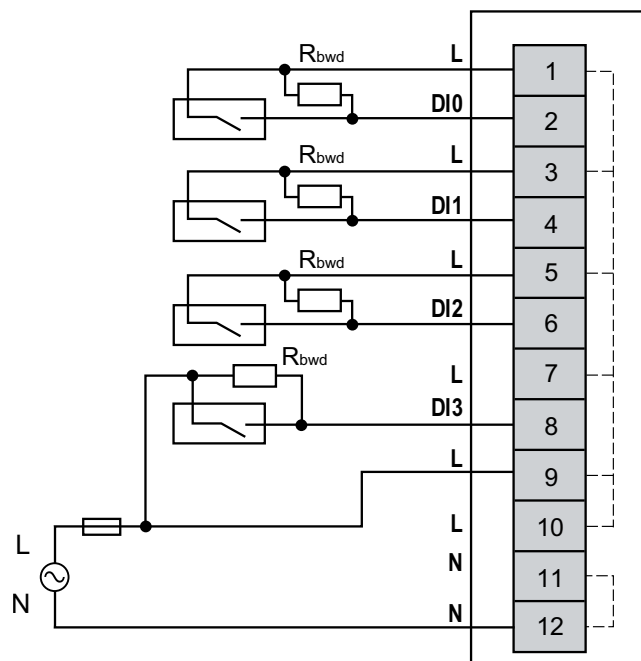

R_{bwd} (required when broken wire detection is enabled): 200 kΩ 1 W, 10%
External Fuse: Type F, 1 A, 120 Vac is mandatory and must be chosen in compliance with IEC60269 standard.

NTSDAI0404H Parameters

Parameters Description

Configurable Parameters

The following table presents the configurable parameters for the NTSDAI0404H module:

Displayed Name <i>Parameter Name</i>	Value	Data type	Description
Device Mode <i>DeviceMode</i>	0: Normal * 1: Optional 2: Virtual reserved	ENUM	Allows you to select the device mode: <ul style="list-style-type: none"> • Normal: The module is part of the software configuration and is physically connected in the cluster. • Optional: The module is part of the software configuration. A dummy module or the configured module must be physically installed in the cluster. Whether either module is present does not cause a configuration error to be detected. • Virtual reserved: The module is part of the software configuration. A dummy module must be physically installed in the cluster. If the virtual module is physically installed in the cluster, a configuration error is detected.
Diag Enable Broken Wire <i>DiagEnableBrokenWire</i> ⁽¹⁾	FALSE TRUE *	BOOL	Enables or disables the broken wire diagnostics.
Diag Enable External Power Supply <i>DiagEnableExternalPower-Supply</i> ⁽¹⁾	FALSE TRUE *	BOOL	Enables or disables the external power supply diagnostics.
* Parameter default value ⁽¹⁾ Online modification is allowed.			

The following table presents the configurable parameters for the channels of the NTSDAI0404H module:

Displayed Name <i>Parameter Name</i>	Value	Data type	Description
Channel Enabled <i>ChannelEnable</i> ⁽¹⁾	TRUE * FALSE	BOOL	Determines whether a channel is enabled or disabled.
Filter <i>Filter</i> ⁽¹⁾	Range: 5.8...20 ms Interval: 0.1 ms 5.8 ms*	FLOAT	Allows reducing the effect of bounce on the input. Changes to the signal are only detected if the pulse width of the input signal is longer than the filter time.
* Parameter default value ⁽¹⁾ Online modification is allowed.			

Implicit Data

The following table presents the input implicit data for the module:

Parameter Name	Value	Data type Size in bytes R/W	Description
GCS	0...255	BYTE 1 R/-	Group Cyclic Status Bit 0: Data quality Bit 1: General module status Bit 2: I/O status Bit 3: N/A Bit 4: N/A Bit 5: Advisory status Bit 6: N/A Bit 7: Data freshness NOTE: For more information, refer to Modicon Edge I/O - Diagnostic Data - User Guide.
ChannelHealth0_7 ⁽¹⁾	0...255	BYTE 1 R/-	Bit 0...7 = Status of channel 0...7 <ul style="list-style-type: none"> Bit = FALSE: Channel is invalid or not present. Bit = TRUE: Channel is valid or disabled.
IValue0_7	0...255	BYTE 1 R/-	Value of the input channels (Bit field). Bit 0...7 = Value of channel 0...7 NOTE: Unused bits are reserved.

⁽¹⁾ This parameter is not part of the implicit data if the optimized I/O profile is selected.

Explicit Data

The following table presents the explicit data for the channels of the module:

Parameter Name	Value	Data type Size in bytes R/W	Description
ChannelFault	0...255	BYTE R/-	Provides the following detected error on the channel: Bit 0: Broken wire error detected Bit 2: External power supply error detected NOTE: Unused bits are reserved.
IValue	TRUE = Channel is in logic state 1 FALSE = Channel is in logic state 0	BOOL R/-	Value of the input channel.

NTSDAI0804 Discrete Input Module, 8 Inputs, 100...120 Vac, 1-wire

What's in This Chapter

NTSDAI0804 Presentation	133
NTSDAI0804 Characteristics.....	137
NTSDAI0804 Wiring	140
NTSDAI0804 Parameters	141

NTSDAI0804 Presentation

Main Characteristics

The following table describes the main characteristics of the NTSDAI0804 input module :

Main Characteristics	Value
Product or component type	Discrete AC input module
Number of Input channels	8
Groups of channels	1 group of 8 channels
Nominal input voltage	100...120 Vac
Input logic type	Sink
Operating mode	Asynchronous

Purchasing Information

The following figure shows the elements of the Modicon Edge I/O NTS NTSDAI0804 input module:

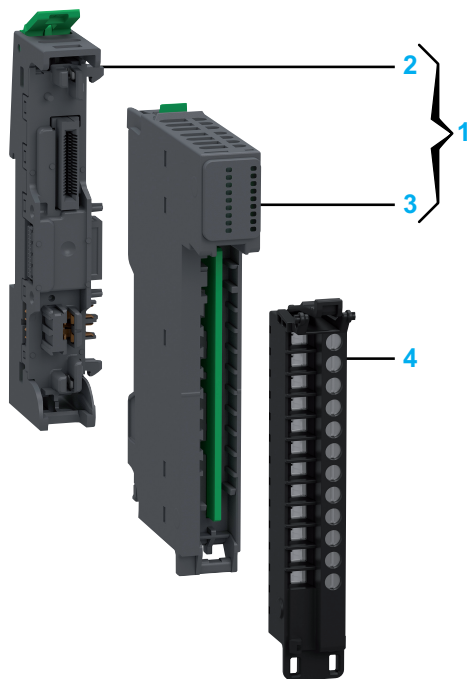

Number	Reference	Description
1	NTSDAI0804K	Base + Module (kit) NOTE: The module and its corresponding base can be purchased as a kit.
2	NTSXBA0100H	Spare Base, 1 Slot, for Input/Output Common or Expert Module, Hardened
3	NTSDAI0804	Discrete Input Module, 8 Inputs, 100...120 Vac, 1-wire
4	NTSXTB12211H NTSXTB12011H NTSXTB12210H NTSXTB12010H	Spring Terminal Block, 12 Points, 5 mm Pitch, With Cover, AC, use on Low Height Module, Hardened Screw Terminal Block, 12 Points, 5 mm Pitch, With Cover, AC, use on Low Height Module, Hardened Spring Terminal Block, 12 Points, 5 mm Pitch, Without Cover, AC, use on Low Height Module, Hardened Screw Terminal Block, 12 Points, 5 mm Pitch, Without Cover, AC, use on Low Height Module, Hardened NOTE: The terminal blocks are purchased separately.

NOTE: For more information on accessories and spare parts, refer to Modicon Edge I/O - System Planning and Installation Guide.

Physical Description

The following figure presents the elements of the module:

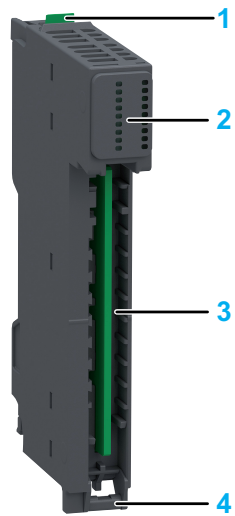

- 1: Release button for disengaging the module from the base
- 2: Status LEDs
- 3: Slot for the terminal block
- 4: Hinge for the terminal block installation

Status LEDs

The following figure presents the NTSDAI0804 status LEDs:

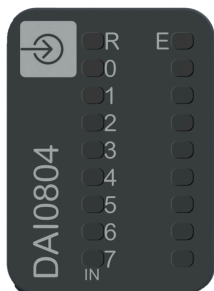

The following table describes the status of LEDs:

R (Green)	E (Red)	IN0...7 (Green)	Description
Initialization and non-operational states			
OFF	OFF	OFF	Indicates that the module is not energized.
OFF	Fast Flash	-	Indicates that the module has detected a system error.
Regular Flash	OFF	-	Indicates that the firmware is being updated.
Regular Flash	ON	-	Indicates that a module mismatch is detected.
Single Flash	OFF	-	Indicates that the module is energized and not configured.
Operational state			
ON	OFF	-	Indicates that the module is energized, configured and operational.
ON	-	ON	Indicates that the corresponding input channel is activated.
ON	-	OFF	Indicates that the corresponding input channel is deactivated.
ON	Regular Flash	OFF	Indicates one of the following: <ul style="list-style-type: none"> • 24 Vdc field power error detection. • Sensor power supply error detection.
ON	Regular Flash	Regular Flash	Indicates that a broken wire error is detected.

The following graphic depicts the system status of LEDs during module operation:

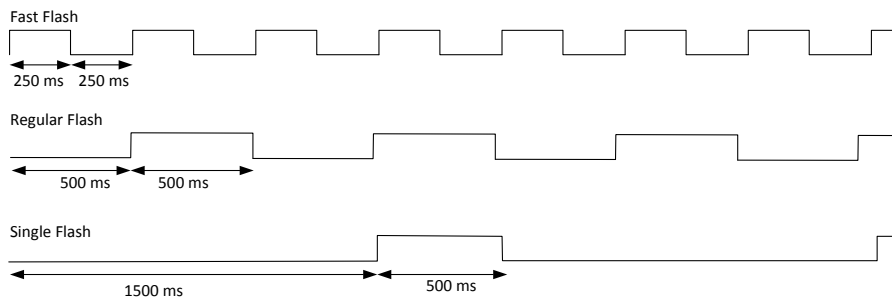

NTSDAI0804 Characteristics

Overview

This section provides a general description of the characteristics of the module.

⚠ WARNING
UNINTENDED EQUIPMENT OPERATION
Do not exceed any of the rated values specified in the environmental and electrical characteristics tables.
Failure to follow these instructions can result in death, serious injury, or equipment damage.

For more information on environmental characteristics, refer to Modicon Edge I/O - System Planning and Installation Guide.

Dimensions

The following figure presents the external dimensions of the assembled module:

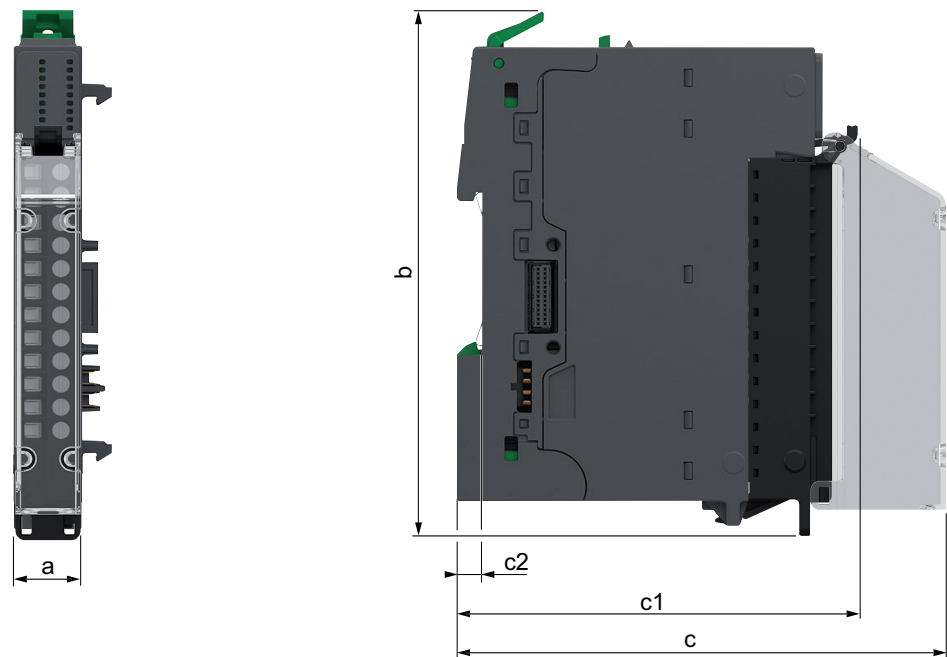

- a**: 15 mm (0.59 in)
- b**: 116.6 mm (4.57 in)
- c**: 107.5 mm (4.21 in)
- c1**: 88.2 mm (3.46 in)
- c2**: 5.6 mm (0.2 in)

Weight

- NTSDAI0804: 48 g (1.69 oz)
- NTSDAI0804K: 72 g (2.54 oz)

General Characteristics

The following table describes the general characteristics of the NTSDAI0804 input module:

Characteristics		Value
Input compatibility		Type 1 according to IEC 61131-2
Field power supplied voltage requirements		From an external 100..120 Vac power supply
Power supplied voltage range		85...138 Vac (47...63 Hz)
Bus current consumption		32.4 mA
Field current consumption for sensors, per module		0 mA
Power dissipation		1.33 W
Maximum cable length	Shielded	1,000 m (3,280 ft)
	Unshielded	600 m (1,968 ft)
Isolation voltage	Between channels	-
	Between groups	-
	Between channel and bus	3,000 Vac
	Between channel and functional earth ground	3,000 Vac
Hot swap supported		Yes
Operating ambient temperature derating		No derating

Input Characteristics

The table below describes the input characteristics of the NTSDAI0804 input module:

Characteristics		Value
Input wiring mode		1-wire
Nominal input current		5.1 mA at 120 Vac 50 Hz
Input voltage	Logic state 1	79 Vac
	Logic state 0	20 Vac
Input current	Logic state 1	2 mA
	Logic state 0	< 2 mA
Input frequency range		47...63 Hz
Response time on input	Logic state 1 to logic state 0	0.5 line cycles maximum
	Logic state 0 to logic state 1	0.5 line cycles maximum
Input filter time	Hardware	5.8...20 ms
	Software	Configurable
Input diagnostic		Broken wire
Monitoring functions		Power supply monitoring (under voltage, power absent) Broken wire detection on sensor input is possible with an additional resistor (Rbwd) in parallel: 220 kΩ, 1 W, 10%. NOTE: Connect the resistor to the sensor connections.

NTSDAI0804 Wiring

Wiring Rules

For more information on the wiring, refer to Modicon Edge I/O - System Planning and Installation Guide.

Wiring Diagram

The input channels of the NTSDAI0804 module require one shared external 120 Vac power supply connected to the terminal block.

⚠ WARNING

UNINTENDED EQUIPMENT OPERATION

Use the sensor and actuator power supply only for supplying power to sensors or actuators connected to the module.

Failure to follow these instructions can result in death, serious injury, or equipment damage.

The following figure illustrates an example of 1-wire connection inputs with a shared external power supply:

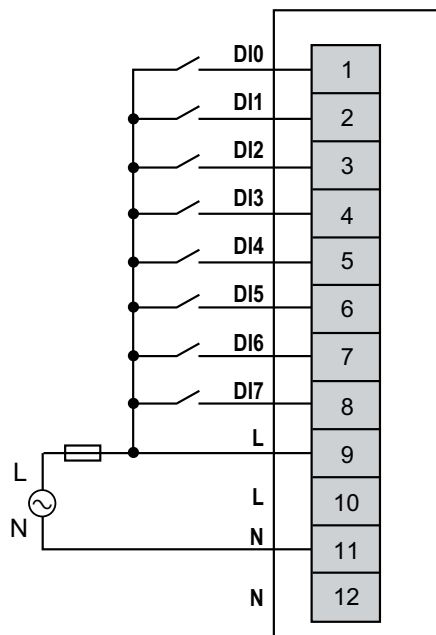

External Fuse: Type F, 1 A, 120 Vac is mandatory and must be chosen in compliance with IEC60269 standard.

NTSDAI0804 Parameters

Parameters Description

Configurable Parameters

The following table presents the configurable parameters for the NTSDAI0804 module:

Displayed Name <i>Parameter Name</i>	Value	Data type	Description
Device Mode <i>DeviceMode</i>	0: Normal * 1: Optional 2: Virtual reserved	ENUM	Allows you to select the device mode: <ul style="list-style-type: none"> • Normal: The module is part of the software configuration and is physically connected in the cluster. • Optional: The module is part of the software configuration. A dummy module or the configured module must be physically installed in the cluster. Whether either module is present does not cause a configuration error to be detected. • Virtual reserved: The module is part of the software configuration. A dummy module must be physically installed in the cluster. If the virtual module is physically installed in the cluster, a configuration error is detected.
Diag Enable Broken Wire <i>DiagEnableBrokenWire</i> ⁽¹⁾	FALSE TRUE *	BOOL	Enables or disables the broken wire diagnostics.
Diag Enable External Power Supply <i>DiagEnableExternalPower-Supply</i> ⁽¹⁾	FALSE TRUE *	BOOL	Enables or disables the external power supply diagnostics.
* Parameter default value ⁽¹⁾ Online modification is allowed.			

The following table presents the configurable parameters for the channels of the NTSDAI0804 module:

Displayed Name <i>Parameter Name</i>	Value	Data type	Description
Channel Enabled <i>ChannelEnable</i> ⁽¹⁾	TRUE * FALSE	BOOL	Determines whether a channel is enabled or disabled.
Filter <i>Filter</i> ⁽¹⁾	Range: 5.8...20 ms Interval: 0.1 ms 5.8 ms*	FLOAT	Allows reducing the effect of bounce on the input. Changes to the signal are only detected if the pulse width of the input signal is longer than the filter time.
* Parameter default value ⁽¹⁾ Online modification is allowed.			

Implicit Data

The following table presents the input implicit data for the module:

Parameter Name	Value	Data type Size in bytes R/W	Description
GCS	0...255	BYTE 1 R/-	Group Cyclic Status Bit 0: Data quality Bit 1: General module status Bit 2: I/O status Bit 3: N/A Bit 4: N/A Bit 5: Advisory status Bit 6: N/A Bit 7: Data freshness NOTE: For more information, refer to Modicon Edge I/O - Diagnostic Data - User Guide.
ChannelHealth0_7 ⁽¹⁾	0...255	BYTE 1 R/-	Bit 0...7 = Status of channel 0...7 <ul style="list-style-type: none"> • Bit = FALSE: Channel is invalid or not present. • Bit = TRUE: Channel is valid or disabled.
IValue0_7	0...255	BYTE 1 R/-	Value of the input channels (Bit field). Bit 0...7 = Value of channel 0...7 NOTE: Unused bits are reserved.

⁽¹⁾ This parameter is not part of the implicit data if the optimized I/O profile is selected.

Explicit Data

The following table presents the explicit data for the channels of the module:

Parameter Name	Value	Data type Size in bytes R/W	Description
ChannelFault	0...255	BYTE R/-	Provides the following detected error on the channel: Bit 0: Broken wire error detected Bit 2: External power supply error detected NOTE: Unused bits are reserved.
IValue	TRUE = Channel is in logic state 1 FALSE = Channel is in logic state 0	BOOL R/-	Value of the input channel.

Discrete Output Modules

What's in This Part

NTSDDO0212H Discrete Output Module, 2 Isolated Outputs, 24 Vdc, 2 A, Source, Protected, 1-/2-/3-wire, Hardened	144
NTSDDO0402/NTSDDO0402H Discrete Output Module, 4 Outputs, 24 Vdc, 500 mA, Source, Diagnostics, Protected, 1-/2-/3-wire, Standard/Hardened	156
NTSDDO0602 Discrete Output Module, 6 Outputs, 24 Vdc, 500 mA, Source, Protected, 1-/2-/3-wire	167
NTSDDO0802 Discrete Output Module, 8 Outputs, 24 Vdc, 2 A, Source, Protected, External Supply, 1-wire	177
NTSDDO0802X Discrete Output Module, 8 Outputs, 24 Vdc, 500 mA, Source, Protected, 1-/2-wire.....	187
NTSDDO1602 Discrete Output Module, 16 Outputs, 24 Vdc, 500 mA, Source, Protected, 1-wire.....	197
NTSDDO1602X/NTSDDO1602XH Discrete Output Module, 16 Outputs, 24 Vdc, 500 mA, Source, Protected, 1-/2-wire, Standard/Hardened	209
NTSDDO1602XA/NTSDDO1602XAH Discrete Output Module, 16 Outputs, 24 Vdc, 500 mA, Source, Protected, External Supply, 1-/2-wire, Standard/Hardened	220
NTSDAO0205 Discrete Output Module, 2 Outputs, 1 A, 100...240 Vac, 1-/2-/3-wire	231
NTSDAO0415/NTSDAO0415H Discrete Output Module, 4 Isolated Outputs, 2 A, 100...240 Vac, 1-/2-/3-wire, Standard/Hardened.....	241
NTSDRC0215 Relay Output Module, 2 Isolated Outputs, NO/NC, 2 A, 5...125 Vdc, 24...240 Vac	251
NTSDRC0415/NTSDRC0415H Relay Output Module, 4 Isolated Outputs, NO/NC, 5 A, 5...125 Vdc, 24...240 Vac, Standard/Hardened	263
NTSDRA0615 Relay Output Module, 6 Isolated Outputs, NO, 2 A, 5...125 Vdc, 24...240 Vac	274

NTSDDO0212H Discrete Output Module, 2 Isolated Outputs, 24 Vdc, 2 A, Source, Protected, 1-/2-/3-wire, Hardened

What's in This Chapter

NTSDDO0212H Presentation.....	144
NTSDDO0212H Characteristics	148
NTSDDO0212H Wiring	151
NTSDDO0212H Parameters	153

NTSDDO0212H Presentation

Main Characteristics

The following table describes the main characteristics of the NTSDDO0212H output module:

Main Characteristics	Value
Product or component type	Discrete DC output module
Number of output channels	2
Groups of output channels	2 groups of 1 channel isolated (if externally supplied) or 1 group of 2 channels non isolated (if powered by internal field power supply)
Output logic type	Source
Output voltage	24 Vdc
Operating mode	Synchronous and isochronous

Purchasing Information

The following figure shows the elements of the Modicon Edge I/O NTS NTSDDO0212H output module:

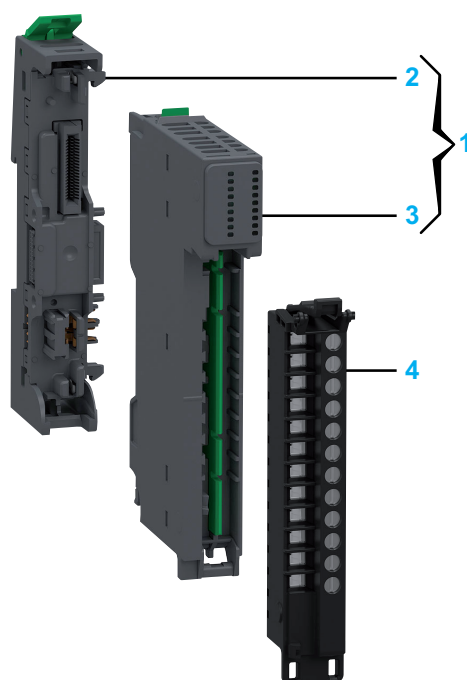

Number	Reference	Description
1	NTSDDO0212HK	Base + Module (kit) NOTE: The module and its corresponding base can be purchased as a kit.
2	NTSXBA0100H	Spare Base, 1 Slot, for Input/Output Common or Expert Module, Hardened
3	NTSDDO0212H	Discrete Output Module, 2 Isolated Outputs, 24 Vdc, 2 A, Source, Protected, 1-/2-/3-wire, Hardened
4	NTSXTB12200H	Spring Terminal Block, 12 Points, 5 mm Pitch, Without Cover, use on Low Height Module, Hardened
	NTSXTB12201H	Spring Terminal Block, 12 Points, 5 mm Pitch, With Cover, use on Low Height Module, Hardened
	NTSXTB12000H	Screw Terminal Block, 12 Points, 5 mm Pitch, Without Cover, use on Low Height Module, Hardened
	NTSXTB12001H	Screw Terminal Block, 12 Points, 5 mm Pitch, With cover, use on Low Height Module, Hardened
		NOTE: The terminal blocks are purchased separately.

NOTE: For more information on accessories and spare parts, refer to Modicon Edge I/O - System Planning and Installation Guide.

Physical Description

The following figure presents the elements of the module:

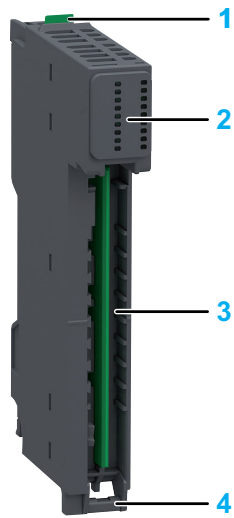

- 1: Release button for disengaging the module from the base
- 2: Status LEDs
- 3: Slot for the terminal block
- 4: Hinge for the terminal block installation

Status LEDs

The following figure presents the NTSDDO0212H status LEDs:



The following table describes the status of LEDs:

R (Green)	E (Red)	OUT0...1 (Green)	Description
Initialization and non-operational states			
OFF	OFF	OFF	Indicates that the module is not energized.
OFF	Fast Flash	-	Indicates that the module has detected a system error.
Regular Flash	OFF	-	Indicates that the firmware is being updated.
Regular Flash	ON	-	Indicates that a module mismatch is detected.
Single Flash	OFF	-	Indicates that the module is energized and not configured.
Operational state			
ON	OFF	-	Indicates that the module is energized, configured and operational.
ON	-	ON	Indicates that the corresponding output channel is activated.
ON	-	OFF	Indicates that the corresponding output channel is deactivated.
ON	Regular Flash	OFF	Indicates one of the following: <ul style="list-style-type: none"> • 24 Vdc field power error detection. • Sensor power supply error detection.
ON	Regular Flash	Regular Flash	Indicates that a short circuit error is detected.

The following graphic depicts the system status of LEDs during module operation:

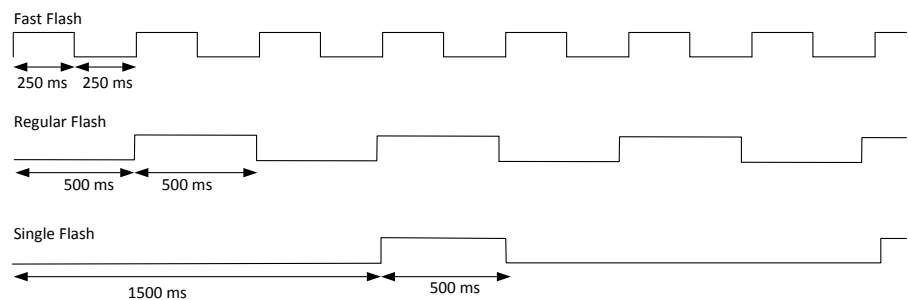

NTSDDO0212H Characteristics

Overview

This section provides a general description of the characteristics of the module.

⚠ WARNING

UNINTENDED EQUIPMENT OPERATION

Do not exceed any of the rated values specified in the environmental and electrical characteristics tables.

Failure to follow these instructions can result in death, serious injury, or equipment damage.

For more information on environmental characteristics, refer to Modicon Edge I/O - System Planning and Installation Guide.

Dimensions

The following figure presents the external dimensions of the assembled module:

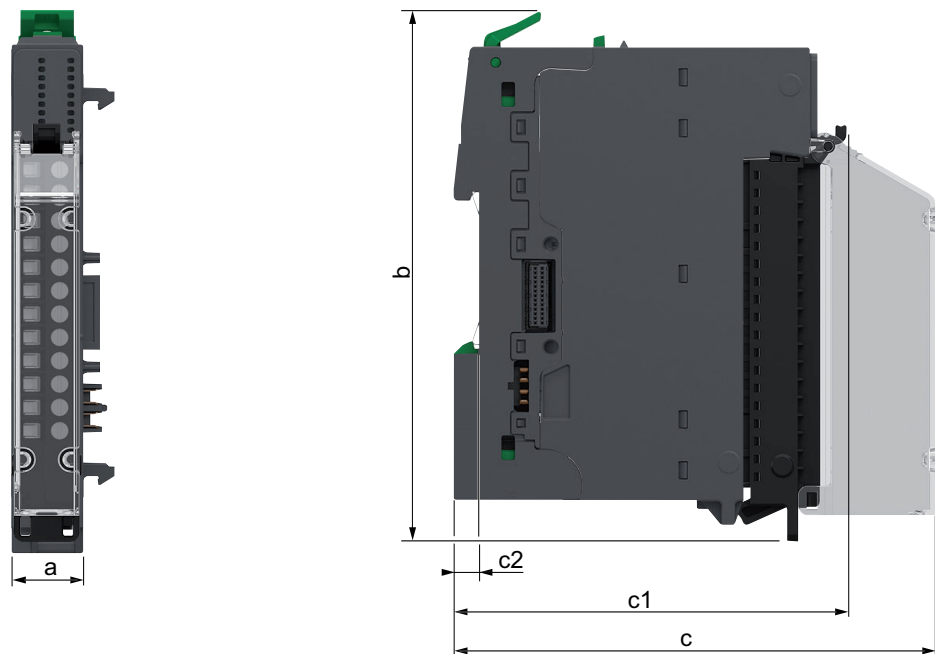

- a: 15 mm (0.59 in)
- b: 116.6 mm (4.57 in)
- c: 107.5 mm (4.21 in)
- c1: 88.2 mm (3.46 in)
- c2: 5.6 mm (0.2 in)

Weight

- NTSDDO0212H: 48 g (1.69 oz)
- NTSDDO0212HK: 72 g (2.54 oz)

General Characteristics

The following table describes the general characteristics of the NTSDDO0212H output module:

Characteristics		Value
Output compatibility		1-/2-/3-wire
Field power supplied voltage requirements		<ul style="list-style-type: none"> • From the 24 Vdc field power • From an external power supply
Power supplied voltage range		20.4...28.8 Vdc
Bus current consumption		27.6 mA
Field current consumption for actuators, per module		4 A
Power dissipation		1.32 W
Maximum cable length	Shielded	50 m (164 ft)
	Unshielded	50 m (164 ft)
Isolation voltage	Between channels	500 Vac (with external power supply)
	Between groups	-
	Between channel and bus	1,500 Vac
	Between channel and functional earth ground	1,500 Vac
Hot swap supported		Yes
Operating ambient temperature derating	Correct mounting position ⁽¹⁾	4 A per module: up to 65 °C (149 °F) 3 A per module: 65...70 °C (149...158 °F)
	Accepted mounting position ⁽¹⁾	4 A per module: up to 50 °C (122 °F) 3.5 A per module: 50...55 °C (122...131 °F) 3 A per module: 55...60 °C (131...140 °F)
Module overload and short circuit protection		Yes, with eFuse. NOTE: When in shutdown following the detection of an overload or short circuit error, the 24 Vdc field power must be power cycled after you have resolved the source of the error.
⁽¹⁾ For information about mounting positions, refer to Modicon Edge I/O - System Planning and Installation Guide.		

Output Characteristics

The table below describes the output characteristics of the NTSDDO0212H output module:

Characteristics		Value
Output type		Transistor
Output wiring mode		1-/2-/3-wire
Output current	Channel current	2 A
	Module current	4 A
Minimum switching current		None
Maximum switching frequency		1 kHz for resistive load, $0.5 / L I^2$ Hz
Response time on output	Logic state 1 to logic state 0	120 μ s maximum
	Logic state 0 to logic state 1	75 μ s maximum
OFF-state leakage/channel		< 0.1 μ A
ON-state drop/channel		<ul style="list-style-type: none"> < 0.25 Vdc maximum from external power supply < 0.35 Vdc from power distribution module
Paralleling of outputs	For redundant control of load	Yes if powered from same source
Output protection	Overload	Yes
	Reverse polarity	Yes, transient-voltage-suppression on output (with external fast blow fuse 5 A)
	Short circuit	Yes
Output diagnostic		<ul style="list-style-type: none"> Power supply monitoring (under voltage, power absent) Short circuit and overload

NTSDDO0212H Wiring

Wiring Rules

For more information on the wiring, refer to Modicon Edge I/O - System Planning and Installation Guide.

Wiring Diagrams

This module allows the use of an external power supply to energize the actuators. To maintain the isolation between channels, use two independent power supplies.

⚠ WARNING

UNINTENDED EQUIPMENT OPERATION

Use the sensor and actuator power supply only for supplying power to sensors or actuators connected to the module.

Failure to follow these instructions can result in death, serious injury, or equipment damage.

The following figure illustrates an example of 2-wire connection outputs with the internal power supply without isolation between channels:

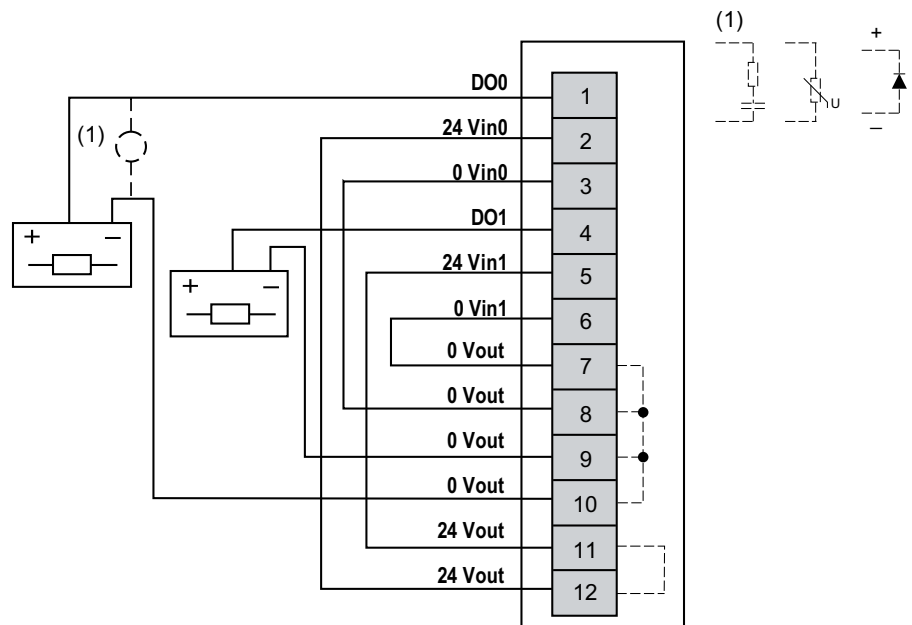

The following figure illustrates an example of 2-/3-wire connection outputs with an external power supply and isolation between channels:

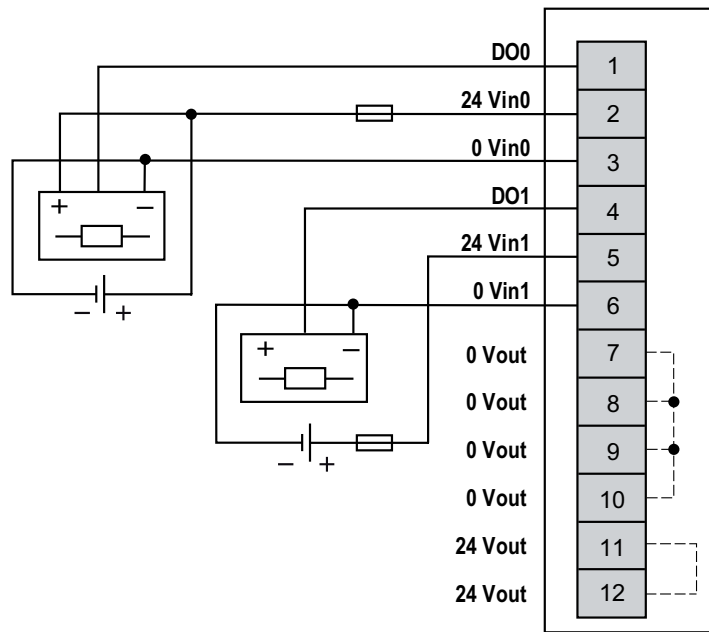

External Fuse: Type F, 5 A, 24 Vdc is mandatory and must be chosen in compliance with IEC60269 standard.

NTSDDO0212H Parameters

Parameters Description

Configurable Parameters

The following table presents the configurable parameters for the NTSDDO0212H module:

Displayed Name <i>Parameter Name</i>	Value	Data type	Description
Device Mode <i>DeviceMode</i>	0: Normal * 1: Optional 2: Virtual reserved	ENUM	Allows you to select the device mode: <ul style="list-style-type: none"> • Normal: The module is part of the software configuration and is physically connected in the cluster. • Optional: The module is part of the software configuration. A dummy module or the configured module must be physically installed in the cluster. Whether either module is present does not cause a configuration error to be detected. • Virtual reserved: The module is part of the software configuration. A dummy module must be physically installed in the cluster. If the virtual module is physically installed in the cluster, a configuration error is detected.
Rearming Output Mode <i>RearmOutputMode</i>	0: Latched Off 1: Auto Recovery *	ENUM	Allows you to select the rearming mode for an output channel who are latched off due to a detected error. Two modes are available: <ul style="list-style-type: none"> • Latched Off: The channel is rearmed if the cause of the error is no longer present, and a rising edge on RearmOutputCmd is applied. • Auto Recovery: The output channel is rearmed automatically if the cause of the error is no longer present for a predefined delay.
Diag Enable Internal Field Power Supply <i>DiagEnablePDM</i> ⁽¹⁾	FALSE TRUE *	BOOL	Enables or disables the field power supply diagnostics.
* Parameter default value (1) Online modification is allowed.			

The following table presents the configurable parameters for the channels of the NTSDDO0212H module:

Displayed Name <i>Parameter Name</i>	Value	Data type	Description
Channel Enabled <i>ChannelEnable</i> ⁽¹⁾	TRUE * FALSE	BOOL	Determines whether a channel is enabled or disabled.
Fallback Mode <i>OutputFallbackMode</i>	0: Fallback Value * 1: Maintain	ENUM	Allows you to select the behavior for the output in case of a communication interruption: <ul style="list-style-type: none"> • Fallback Value: Sets the output at the configured Predefined Fallback Value value. • Maintain: The output remains in its present state.
Predefined Fallback Value <i>OutputFallbackValue</i>	0 * 1	ENUM	Determines the state for the output in case of a communication interruption and Fallback Mode parameter is set to Predefined Fallback Value .
* Parameter default value (1) Online modification is allowed.			

Implicit Data

The following table presents the input implicit data for the module:

Parameter Name	Value	Data type Size in bytes R/W	Description
GCS	0...255	BYTE 1 R/-	Group Cyclic Status Bit 0: Data quality Bit 1: General module status Bit 2: I/O status Bit 3: Receive status Bit 4: Output status Bit 5: Advisory status Bit 6: N/A Bit 7: Data freshness NOTE: For more information, refer to Modicon Edge I/O - Diagnostic Data - User Guide.
ChannelHealth0_7 ⁽¹⁾	0...255	BYTE 1 R/-	Bit 0...7 = Status of channel 0...7 <ul style="list-style-type: none"> Bit = FALSE: Channel is invalid or not present. Bit = TRUE: Channel is valid or disabled.
⁽¹⁾ This parameter is not part of the implicit data if the optimized I/O profile is selected.			

The following table presents the output implicit data for the module:

Parameter Name	Value	Data type Size in bytes R/W	Description
RearmOutputCmd	TRUE FALSE	BOOL R/W	If the Rearming Output Mode parameter is set to Latched Off and the cause of the detected error is no longer present, then on a rising edge, it rearms the output channels.
QValue0_7	0...255	BYTE 1 R/W	Value of the output channels (Bit field). Bit 0...7 = Value of channel 0...7 NOTE: Unused bits are reserved.

Explicit Data

The following table presents the explicit data for the channels of the module:

Parameter Name	Value	Data type Size in bytes R/W	Description
<i>ChannelFault</i>	0...255	BYTE R/-	Provides the following detected error on the channel: Bit 1: Short circuit error detected Bit 2: External power supply error detected Bit 4: Internal power supply error detected NOTE: Unused bits are reserved.
<i>QValue</i>	TRUE = Channel is in logic state 1 FALSE = Channel is in logic state 0	BOOL R/W	Value of the output channel.

NTSDDO0402/NTSDDO0402H Discrete Output Module, 4 Outputs, 24 Vdc, 500 mA, Source, Diagnostics, Protected, 1-/2-/3-wire, Standard/Hardened

What's in This Chapter

NTSDDO0402/NTSDDO0402H Presentation	156
NTSDDO0402/NTSDDO0402H Characteristics	160
NTSDDO0402/NTSDDO0402H Wiring	163
NTSDDO0402/NTSDDO0402H Parameters	164

NTSDDO0402/NTSDDO0402H Presentation

Main Characteristics

The following table describes the main characteristics of the NTSDDO0402/NTSDDO0402H output modules:

Main Characteristics	Value
Product or component type	Discrete DC output module with diagnostics
Number of output channels	4
Groups of output channels	1 group of 4 channels non isolated
Output logic type	Source
Output voltage	24 Vdc
Operating mode	Asynchronous

Purchasing Information

The following figure shows the elements of the Modicon Edge I/O NTS NTSDDO0402/NTSDDO0402H output modules:

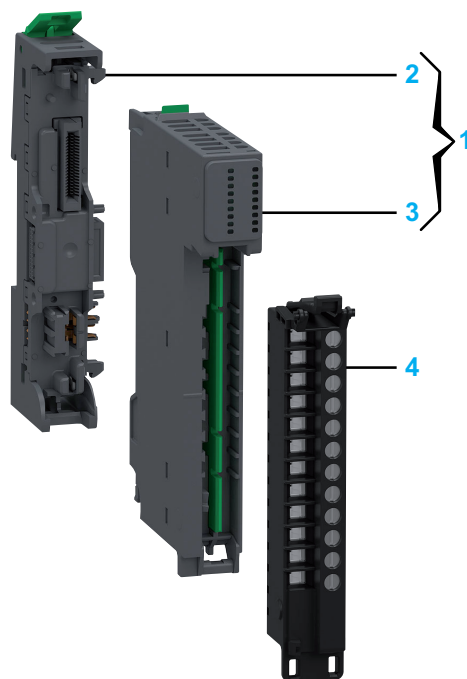

Number	Reference	Description
1	NTSDDO0402K/ NTSDDO0402HK	Base + Module (kit) NOTE: The module and its corresponding base can be purchased as a kit.
2	NTSXBA0100H	Spare Base, 1 Slot, for Input/Output Common or Expert Module, Hardened
3	NTSDDO0402	Discrete Output Module, 4 Outputs, 24 Vdc, 500 mA, Source, Diagnostics, Protected, 1-/2-/3-wire
	NTSDDO0402H	Discrete Output Module, 4 Outputs, 24 Vdc, 500 mA, Source, Diagnostics, Protected, 1-/2-/3-wire, Hardened
4	NTSXTB12200H	Spring Terminal Block, 12 Points, 5 mm Pitch, Without Cover, use on Low Height Module, Hardened
	NTSXTB12201H	Spring Terminal Block, 12 Points, 5 mm Pitch, With Cover, use on Low Height Module, Hardened
	NTSXTB12000H	Screw Terminal Block, 12 Points, 5 mm Pitch, Without Cover, use on Low Height Module, Hardened
	NTSXTB12001H	Screw Terminal Block, 12 Points, 5 mm Pitch, With cover, use on Low Height Module, Hardened
		NOTE: The terminal blocks are purchased separately.

NOTE: For more information on accessories and spare parts, refer to Modicon Edge I/O - System Planning and Installation Guide.

Physical Description

The following figure presents the elements of the module:

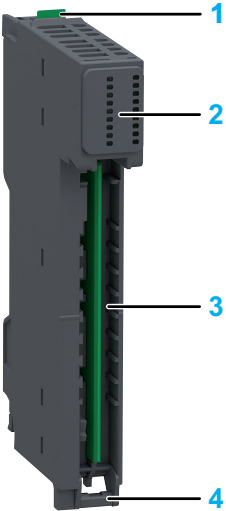

- 1: Release button for disengaging the module from the base
- 2: Status LEDs
- 3: Slot for the terminal block
- 4: Hinge for the terminal block installation

Status LEDs

The following figure presents the NTSDDO0402/NTSDDO0402H status LEDs:

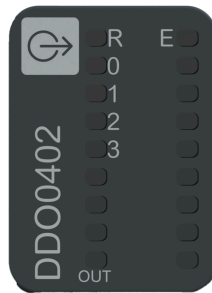

The following table describes the status of LEDs:

R (Green)	E (Red)	OUT0...3 (Green)	Description
Initialization and non-operational states			
OFF	OFF	OFF	Indicates that the module is not energized.
OFF	Fast Flash	-	Indicates that the module has detected a system error.
Regular Flash	OFF	-	Indicates that the firmware is being updated.
Regular Flash	ON	-	Indicates that a module mismatch is detected.
Single Flash	OFF	-	Indicates that the module is energized and not configured.
Operational state			
ON	OFF	-	Indicates that the module is energized, configured and operational.
ON	-	ON	Indicates that the corresponding output channel is activated.
ON	-	OFF	Indicates that the corresponding output channel is deactivated.
ON	Regular Flash	OFF	Indicates one of the following: <ul style="list-style-type: none"> • 24 Vdc field power error detection. • Sensor power supply error detection.
ON	Regular Flash	Regular Flash	Indicates one of the following: <ul style="list-style-type: none"> • Broken wire detection. • Short circuit detection. • Readback error detection.

The following graphic depicts the system status of LEDs during module operation:

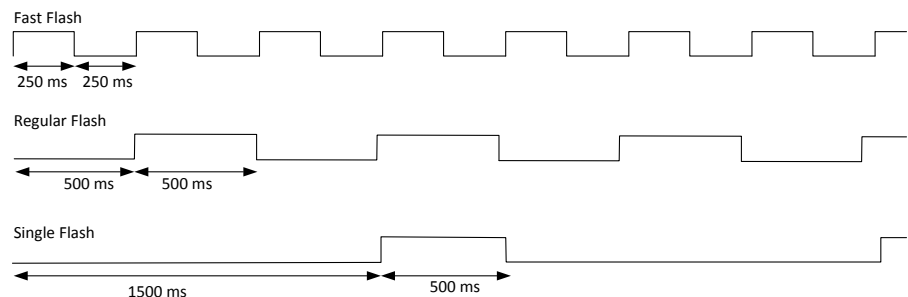

NTSDDO0402/NTSDDO0402H Characteristics

Overview

This section provides a general description of the characteristics of the module.

⚠ WARNING

UNINTENDED EQUIPMENT OPERATION

Do not exceed any of the rated values specified in the environmental and electrical characteristics tables.

Failure to follow these instructions can result in death, serious injury, or equipment damage.

For more information on environmental characteristics, refer to Modicon Edge I/O - System Planning and Installation Guide.

Dimensions

The following figure presents the external dimensions of the assembled module:

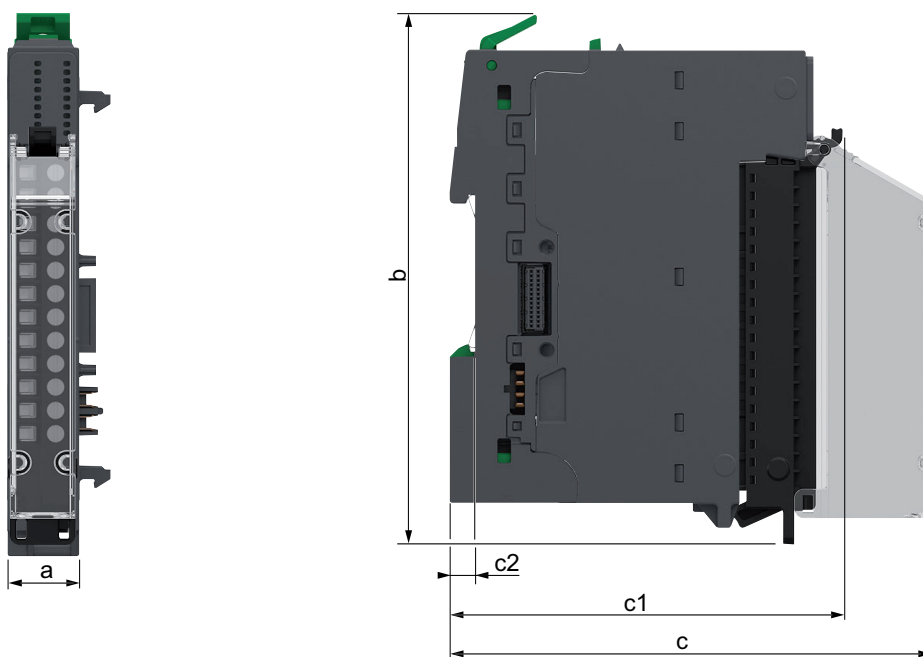

- a:** 15 mm (0.59 in)
- b:** 116.6 mm (4.57 in)
- c:** 107.5 mm (4.21 in)
- c1:** 88.2 mm (3.46 in)
- c2:** 5.6 mm (0.2 in)

Weight

- NTSDDO0402: 45 g (1.59 oz)
- NTSDDO0402K: 71 g (2.51 oz)
- NTSDDO0402H: 46 g (1.63 oz)
- NTSDDO0402HK: 73 g (2.57 oz)

General Characteristics

The following table describes the general characteristics of the NTSDDO0402/
 NTSDDO0402H output modules:

Characteristics		Value
Output compatibility		1-/2-/3-wire
Field power supplied voltage requirements		From the 24 Vdc field power
Power supplied voltage range		20.4...28.8 Vdc
Bus current consumption		30 mA
Field current consumption for actuators, per module		4 A
Power dissipation		1.45 W
Maximum cable length	Shielded	600 m (1,968 ft)
	Unshielded	600 m (1,968 ft)
Isolation voltage	Between channels	-
	Between groups	-
	Between channel and bus	1,500 Vac
	Between channel and functional earth ground	1,500 Vac
Hot swap supported		Yes
Operating ambient temperature derating		No derating
Module overload and short circuit protection		Yes, with eFuse. NOTE: When in shutdown following the detection of an overload or short circuit error, the 24 Vdc field power must be power cycled after you have resolved the source of the error.

Output Characteristics

The table below describes the output characteristics of the NTSDDO0402/
 NTSDDO0402H output modules:

Characteristics		Value
Output type		Transistor
Output wiring mode		1-/2-/3-wire
Output current	Channel current	0.5 A
	Module current	2 A
Minimum switching current		None
Maximum switching frequency		1 kHz for resistive load, 0.5 / LI ² Hz
Response time on output	Logic state 1 to logic state 0	110 μs maximum
	Logic state 0 to logic state 1	90 μs maximum
OFF-state leakage/channel		< 0.2 μA
ON-state drop/channel		< 0.1 Vdc
Paralleling of outputs	For redundant control of load	Yes (maximum 2)
Output protection	Overload	Yes
	Reverse polarity	Yes, transient-voltage-suppression on output
	Short circuit	Yes
Output diagnostic		<ul style="list-style-type: none"> • Power supply monitoring (under voltage, power absent) • Overload • Short circuit • Broken wire⁽¹⁾ • Readback error
⁽¹⁾ The broken wire monitoring function outputs a pulse at 0 volts every second for a duration of 650 μs. Use the Diag Enable Broken Wire parameter to enable or disable the broken wire diagnostics.		

NTSDDO0402/NTSDDO0402H Wiring

Wiring Rules

For more information on the wiring, refer to Modicon Edge I/O - System Planning and Installation Guide.

Wiring Diagram

The following figure illustrates an example of 2-/3-wire connection outputs:

2-/3-wire output wiring

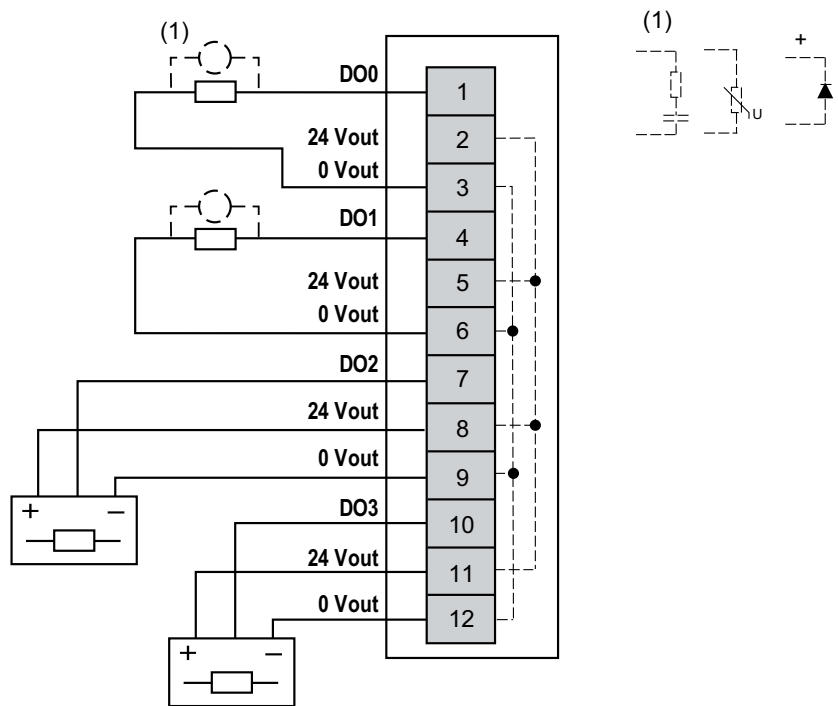

NTSDDO0402/NTSDDO0402H Parameters

Parameters Description

Configurable Parameters

The following table presents the configurable parameters for the NTSDDO0402/
 NTSDDO0402H modules:

Displayed Name <i>Parameter Name</i>	Value	Data type	Description
Device Mode <i>DeviceMode</i>	0: Normal* 1: Optional 2: Virtual reserved	ENUM	Allows you to select the device mode: <ul style="list-style-type: none"> • Normal: The module is part of the software configuration and is physically connected in the cluster. • Optional: The module is part of the software configuration. A dummy module or the configured module must be physically installed in the cluster. Whether either module is present does not cause a configuration error to be detected. • Virtual reserved: The module is part of the software configuration. A dummy module must be physically installed in the cluster. If the virtual module is physically installed in the cluster, a configuration error is detected.
Rearming Output Mode <i>RearmOutputMode</i>	0: Latched Off 1: Auto Recovery*	ENUM	Allows you to select the rearming mode for an output channel which is latched off due to a detected error. Two modes are available: <ul style="list-style-type: none"> • Latched Off: The channel is rearmed if the cause of the error is no longer present, and a rising edge on RearmOutputCmd is applied. • Auto Recovery: The output channel is rearmed automatically if the cause of the error is no longer present for a predefined delay.
Diag Enable Broken Wire <i>DiagEnableBrokenWire⁽¹⁾</i>	FALSE TRUE*	BOOL	Enables or disables the broken wire diagnostics. The broken wire monitoring function outputs a pulse at 0 volts every second for a duration of 650 μ s.
* Parameter default value (¹) Online modification is allowed.			

The following table presents the configurable parameters for the channels of the
 NTSDDO0402/NTSDDO0402H modules:

Displayed Name <i>Parameter Name</i>	Value	Data type	Description
Channel Enabled <i>ChannelEnable⁽¹⁾</i>	TRUE* FALSE	BOOL	Determines whether a channel is enabled or disabled.
Fallback Mode <i>OutputFallbackMode</i>	Fallback Value* Maintain	ENUM	Allows you to select the behavior for the output in case of a communication interruption: <ul style="list-style-type: none"> • Fallback Value: Sets the output at the configured Predefined Fallback Value value. • Maintain: The output remains in its present state.
Predefined Fallback Value <i>OutputFallbackValue</i>	0* 1	ENUM	Determines the state for the output in case of a communication interruption and Fallback Mode parameter is set to Predefined Fallback Value .
* Parameter default value (¹) Online modification is allowed.			

Implicit Data

The following table presents the input implicit data for the module:

Parameter Name	Value	Data type Size in bytes R/W	Description
<i>GCS</i>	0...255	BYTE 1 R/-	Group Cyclic Status Bit 0: Data quality Bit 1: General module status Bit 2: I/O status Bit 3: Receive status Bit 4: Output status Bit 5: Advisory status Bit 6: N/A Bit 7: Data freshness NOTE: For more information, refer to Modicon Edge I/O - Diagnostic Data - User Guide.
<i>QBackValue0_7</i>	0...255	BYTE 1 R/-	Bit 0...7 = Back value of channel 0...7. <i>QbackValue0_7</i> is the feedback from the terminal block of the <i>QValue0_7</i> output. It is set to 1 when the actuator connected to the output is energized.
<i>ChannelHealth0_7</i> ⁽¹⁾	0...255	BYTE 1 R/-	Bit 0...7 = Status of channel 0...7 <ul style="list-style-type: none"> Bit = FALSE: Channel is invalid or not present. Bit = TRUE: Channel is valid or disabled.
⁽¹⁾ This parameter is not part of the implicit data if the optimized I/O profile is selected.			

The following table presents the output implicit data for the module:

Parameter Name	Value	Data type Size in bytes R/W	Description
<i>RearmOutputCmd</i>	TRUE FALSE	BOOL R/W	If the Rearming Output Mode parameter is set to Latched Off and the cause of the detected error is no longer present, then on a rising edge, it rearms the output channels.
<i>QValue0_7</i>	0...255	BYTE 1 R/W	Value of the output channels (Bit field). Bit 0...7 = Value of channel 0...7 NOTE: Unused bits are reserved.

Explicit Data

The following table presents the explicit data for the channels of the module:

Parameter Name	Value	Data type Size in bytes R/W	Description
<i>ChannelFault</i>	0...255	BYTE R/-	Provides the following detected error on the channel: Bit 0: Broken wire error detected Bit 1: Short circuit error detected Bit 4: Internal power supply error detected Bit 5: Readback error detected NOTE: Unused bits are reserved.
<i>QValue</i>	TRUE = Channel is in logic state 1. FALSE = Channel is in logic state 0.	BOOL R/W	Value of the output channel.
<i>QBackValue</i>	TRUE = The actuator connected to the output is energized. FALSE = The actuator connected to the output is not energized.	BOOL R/-	<i>QBackValue</i> is the feedback from the terminal block of the <i>QValue</i> output.

NTSDDO0602 Discrete Output Module, 6 Outputs, 24 Vdc, 500 mA, Source, Protected, 1-/2-/3-wire

What's in This Chapter

NTSDDO0602 Presentation	167
NTSDDO0602 Characteristics	171
NTSDDO0602 Wiring	174
NTSDDO0602 Parameters	175

NTSDDO0602 Presentation

Main Characteristics

The following table describes the main characteristics of the NTSDDO0602 output module:

Main Characteristics	Value
Product or component type	Discrete DC output module
Number of output channels	6
Groups of output channels	3 groups of 2 channels non isolated
Output logic type	Source
Output voltage	24 Vdc
Operating mode	Asynchronous

Purchasing Information

The following figure shows the elements of the Modicon Edge I/O NTS NTSDDO0602 output module:

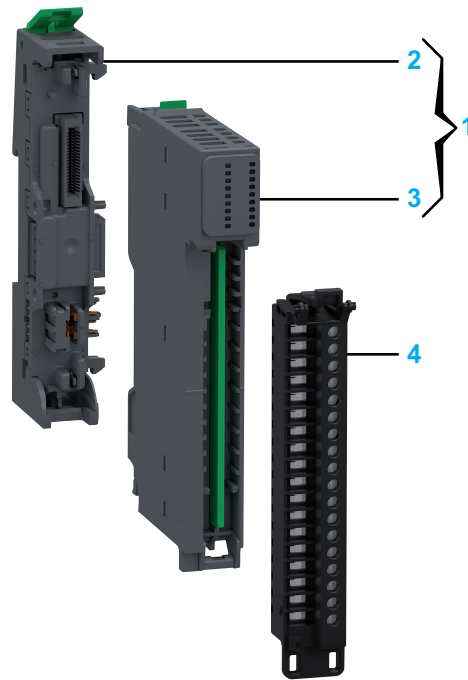

Number	Reference	Description
1	NTSDDO0602K	Base + Module (kit) NOTE: The module and its corresponding base can be purchased as a kit.
2	NTSXBA0100H	Spare Base, 1 Slot, for Input/Output Common or Expert Module, Hardened
3	NTSDDO0602	Discrete Output Module, 6 Outputs, 24 Vdc, 500 mA, Source, Protected, 1-/2-/3-wire
4	NTSXTB18200H	Spring Terminal Block, 18 Points, 3.81 mm Pitch, Without Cover, use on Low Height Module, Hardened
	NTSXTB18201H	Spring Terminal Block, 18 Points, 3.81 mm Pitch, With Cover, use on Low Height Module, Hardened
	NTSXTB18000H	Screw Terminal Block, 18 Points, 3.81 mm Pitch, Without Cover, use on Low Height Module, Hardened
	NTSXTB18001H	Screw Terminal Block, 18 Points, 3.81 mm Pitch, With Cover, use on Low Height Module, Hardened
		NOTE: The terminal blocks are purchased separately.

NOTE: For more information on accessories and spare parts, refer to Modicon Edge I/O - System Planning and Installation Guide.

Physical Description

The following figure presents the elements of the module:

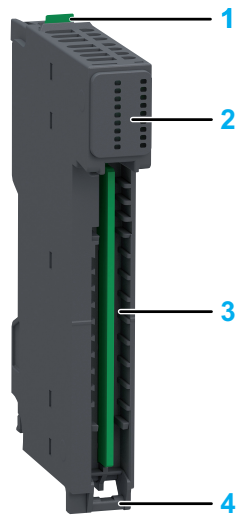

- 1: Release button for disengaging the module from the base
- 2: Status LEDs
- 3: Slot for the terminal block
- 4: Hinge for the terminal block installation

Status LEDs

The following figure presents the NTSDDO0602 status LEDs:

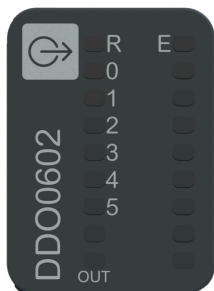

The following table describes the status of LEDs:

R (Green)	E (Red)	OUT0...5 (Green)	Description
Initialization and non-operational states			
OFF	OFF	OFF	Indicates that the module is not energized.
OFF	Fast Flash	-	Indicates that the module has detected a system error.
Regular Flash	OFF	-	Indicates that the firmware is being updated.
Regular Flash	ON	-	Indicates that a module mismatch is detected.
Single Flash	OFF	-	Indicates that the module is energized and not configured.
Operational state			
ON	OFF	-	Indicates that the module is energized, configured and operational.
ON	-	ON	Indicates that the corresponding output channel is activated.
ON	-	OFF	Indicates that the corresponding output channel is deactivated.
ON	Regular Flash	OFF	Indicates one of the following: <ul style="list-style-type: none"> • 24 Vdc field power error detection. • Sensor power supply error detection.
ON	Regular Flash	Regular Flash	Indicates that a short circuit error is detected.

The following graphic depicts the system status of LEDs during module operation:

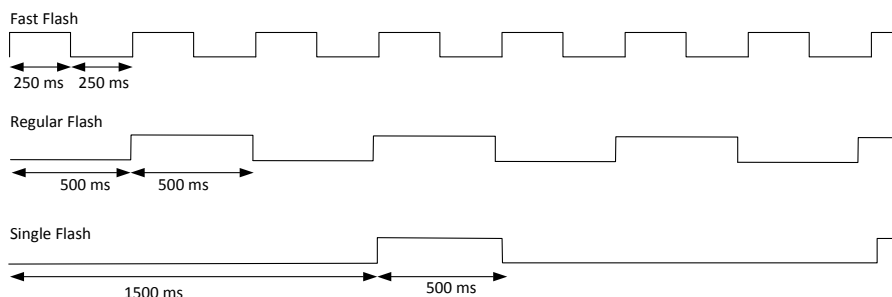

NTSDDO0602 Characteristics

Overview

This section provides a general description of the characteristics of the module.

⚠ WARNING
UNINTENDED EQUIPMENT OPERATION
Do not exceed any of the rated values specified in the environmental and electrical characteristics tables.
Failure to follow these instructions can result in death, serious injury, or equipment damage.

For more information on environmental characteristics, refer to Modicon Edge I/O - System Planning and Installation Guide.

Dimensions

The following figure presents the external dimensions of the assembled module:

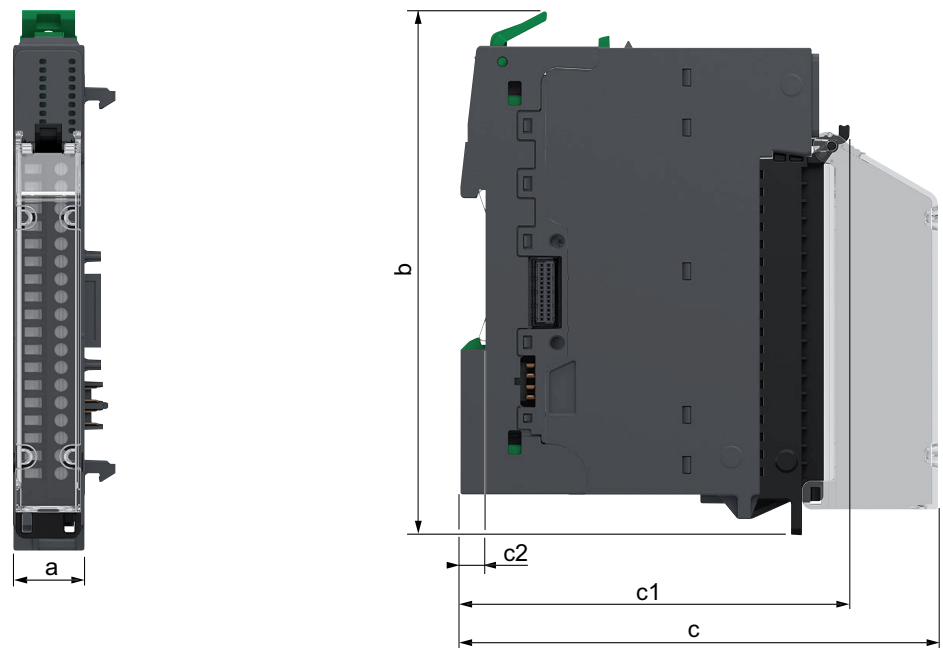

- a:** 15 mm (0.59 in)
- b:** 116.6 mm (4.57 in)
- c:** 107.5 mm (4.21 in)
- c1:** 88.2 mm (3.46 in)
- c2:** 5.6 mm (0.2 in)

Weight

- NTSDDO0602: 48 g (1.69 oz)
- NTSDDO0602K: 73 g (2.57 oz)

General Characteristics

The following table describes the general characteristics of the NTSDDO0602 output module:

Characteristics		Value
Output compatibility		1-/2-/3-wire
Field power supplied voltage requirements		From the 24 Vdc field power
Power supplied voltage range		20.4...28.8 Vdc
Bus current consumption		32.4 mA
Field current consumption for actuators, per module		3,004.3 mA
Power dissipation		1.97 W
Maximum cable length	Shielded	1,000 m (3,280 ft)
	Unshielded	600 m (1,968 ft)
Isolation voltage	Between channels	-
	Between groups	-
	Between channel and bus	1,500 Vac
	Between channel and functional earth ground	1,500 Vac
Hot swap supported		Yes
Operating ambient temperature derating		No derating
Module overload and short circuit protection		Yes, with an eFuse and the auto-retry is every 3 s. NOTE: The eFuse of the module can typically trigger when multiple channels are simultaneously in short circuit to 0 V.

Output Characteristics

The table below describes the output characteristics of the NTSDDO0602 output module:

Characteristics		Value
Output type		Transistor
Output wiring mode		1-/2-/3-wire
Output current	Channel current	0.5 A
	Module current	3 A
Minimum switching current		None
Maximum switching frequency		1 kHz for resistive load, 0.5 / LI ² Hz
Response time on output	Logic state 1 to logic state 0	120 µs maximum
	Logic state 0 to logic state 1	75 µs maximum
OFF-state leakage/channel		< 0.1 µA
ON-state drop/channel		< 0.1 Vdc
Paralleling of outputs	For redundant control of load	Yes (maximum 2)
Output protection	Overload	Yes
	Reverse polarity	Yes, transient-voltage-suppression on output
	Short circuit	Yes
Output diagnostic		<ul style="list-style-type: none"> Power supply monitoring (under voltage, power absent) Short circuit and overload⁽¹⁾
⁽¹⁾ The monitoring of outputs is realized by pair of subsequent outputs: DO0/DO1, DO2/DO3 and DO4/DO5. For more information about the monitoring of outputs, refer to Short Circuit Diagnostic and Recovery Methodology, page 289.		

NTSDDO0602 Wiring

Wiring Rules

For more information on the wiring, refer to Modicon Edge I/O - System Planning and Installation Guide.

Wiring Diagram

The following figure illustrates an example of 2-/3-wire connection outputs:

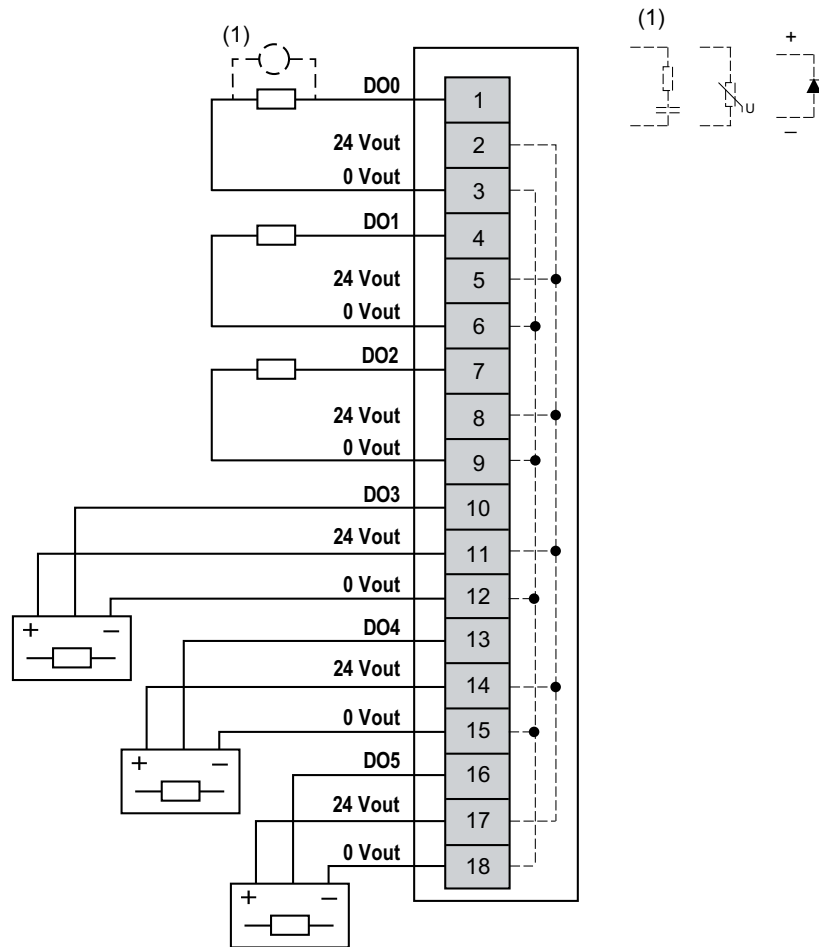

NTSDDO0602 Parameters

Parameters Description

Configurable Parameters

The following table presents the configurable parameters for the NTSDDO0602 module:

Displayed Name <i>Parameter Name</i>	Value	Data type	Description
Device Mode <i>DeviceMode</i>	0: Normal * 1: Optional 2: Virtual reserved	ENUM	Allows you to select the device mode: <ul style="list-style-type: none"> • Normal: The module is part of the software configuration and is physically connected in the cluster. • Optional: The module is part of the software configuration. A dummy module or the configured module must be physically installed in the cluster. Whether either module is present does not cause a configuration error to be detected. • Virtual reserved: The module is part of the software configuration. A dummy module must be physically installed in the cluster. If the virtual module is physically installed in the cluster, a configuration error is detected.
Rearming Output Mode <i>RearmOutputMode</i>	0: Latched Off 1: Auto Recovery *	ENUM	Allows you to select the rearming mode for an output channel which is latched off due to a detected error. Two modes are available: <ul style="list-style-type: none"> • Latched Off: The channel is rearmed if the cause of the error is no longer present, and a rising edge on RearmOutputCmd is applied. • Auto Recovery: The output channel is rearmed automatically if the cause of the error is no longer present for a predefined delay.
* Parameter default value			

The following table presents the configurable parameters for the channels of the NTSDDO0602 module:

Displayed Name <i>Parameter Name</i>	Value	Data type	Description
Channel Enabled <i>ChannelEnable</i> ⁽¹⁾	TRUE * FALSE	BOOL	Determines whether a channel is enabled or disabled.
Fallback Mode <i>OutputFallbackMode</i>	0: Fallback Value * 1: Maintain	ENUM	Allows you to select the behavior for the output in case of a communication interruption: <ul style="list-style-type: none"> • Fallback Value: Sets the output at the configured Predefined Fallback Value value. • Maintain: The output remains in its present state.
Predefined Fallback Value <i>OutputFallbackValue</i>	0 * 1	ENUM	Determines the state for the output in case of a communication interruption and Fallback Mode parameter is set to Predefined Fallback Value .
* Parameter default value			
⁽¹⁾ Online modification is allowed.			

Implicit Data

The following table presents the input implicit data for the module:

Parameter Name	Value	Data type Size in bytes R/W	Description
GCS	0...255	BYTE 1 R/-	Group Cyclic Status Bit 0: Data quality Bit 1: General module status Bit 2: I/O status Bit 3: Receive status Bit 4: Output status Bit 5: Advisory status Bit 6: N/A Bit 7: Data freshness NOTE: For more information, refer to Modicon Edge I/O - Diagnostic Data - User Guide.
ChannelHealth0_7 ⁽¹⁾	0...255	BYTE 1 R/-	Bit 0...7 = Status of channel 0...7 <ul style="list-style-type: none"> Bit = FALSE: Channel is invalid or not present. Bit = TRUE: Channel is valid or disabled.

⁽¹⁾ This parameter is not part of the implicit data if the optimized I/O profile is selected.

The following table presents the output implicit data for the module:

Parameter Name	Value	Data type Size in bytes R/W	Description
RearmOutputCmd	TRUE FALSE	BOOL R/W	If the Rearming Output Mode parameter is set to Latched Off and the cause of the detected error is no longer present, then on a rising edge, it rearms the output channels.
QValue0_7	0...255	BYTE 1 R/W	Value of the output channels (Bit field). Bit 0...7 = Value of channel 0...7 NOTE: Unused bits are reserved.

Explicit Data

The following table presents the explicit data for the channels of the module:

Parameter Name	Value	Data type Size in bytes R/W	Description
ChannelFault	0...255	BYTE R/-	Provides the following detected error on the channel: Bit 1: Short circuit error detected Bit 4: Internal power supply error detected NOTE: Unused bits are reserved.
QValue	TRUE = Channel is in logic state 1 FALSE = Channel is in logic state 0	BOOL R/W	Value of the output channel.

NTSDDO0802 Discrete Output Module, 8 Outputs, 24 Vdc, 2 A, Source, Protected, External Supply, 1-wire

What's in This Chapter

NTSDDO0802 Presentation 177
 NTSDDO0802 Characteristics 181
 NTSDDO0802 Wiring 184
 NTSDDO0802 Parameters 185

NTSDDO0802 Presentation

Main Characteristics

The following table describes the main characteristics of the NTSDDO0802 module:

Main Characteristics	Value
Product or component type	Discrete DC output module
Number of output channels	8
Groups of output channels	2 groups of 4 channels non isolated
Output logic type	Source
Output voltage	24 Vdc
Operating mode	Synchronous and isochronous

Purchasing Information

The following figure shows the elements of the Modicon Edge I/O NTS NTSDDO0802 output module:

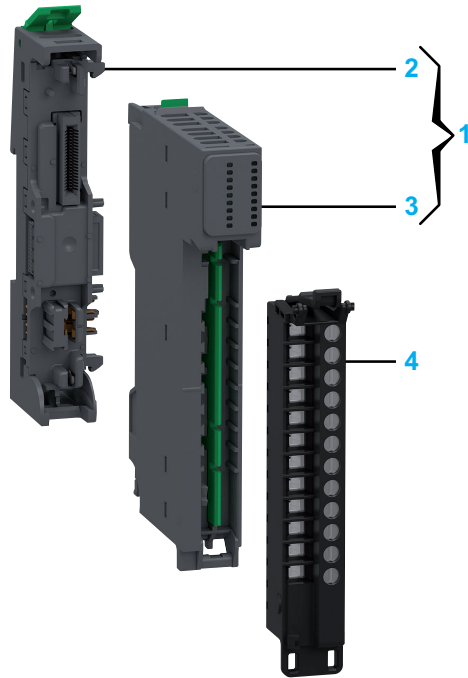

Number	Reference	Description
1	NTSDDO0802K	Base + Module (kit) NOTE: The module and its corresponding base can be purchased as a kit.
2	NTSXBA0100H	Spare Base, 1 Slot, for Input/Output Common or Expert Module, Hardened
3	NTSDDO0802	Discrete Output Module, 8 Outputs, 24 Vdc, 2 A, Source, Protected, External Supply, 1-wire
4	NTSXTB12200H	Spring Terminal Block, 12 Points, 5 mm Pitch, Without Cover, use on Low Height Module, Hardened
	NTSXTB12201H	Spring Terminal Block, 12 Points, 5 mm Pitch, With Cover, use on Low Height Module, Hardened
	NTSXTB12000H	Screw Terminal Block, 12 Points, 5 mm Pitch, Without Cover, use on Low Height Module, Hardened
	NTSXTB12001H	Screw Terminal Block, 12 Points, 5 mm Pitch, With cover, use on Low Height Module, Hardened
		NOTE: The terminal blocks are purchased separately.

NOTE: For more information on accessories and spare parts, refer to Modicon Edge I/O - System Planning and Installation Guide.

Physical Description

The following figure presents the elements of the module:

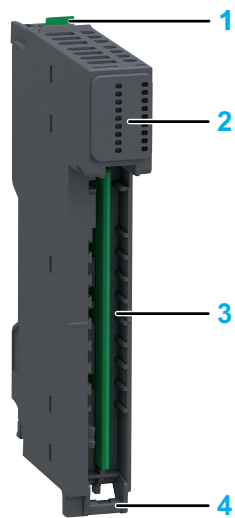

- 1: Release button for disengaging the module from the base
- 2: Status LEDs
- 3: Slot for the terminal block
- 4: Hinge for the terminal block installation

Status LEDs

The following figure presents the NTSDDO0802 status LEDs:



The following table describes the status of LEDs:

R (Green)	E (Red)	OUT0...7 (Green)	Description
Initialization and non-operational states			
OFF	OFF	OFF	Indicates that the module is not energized.
OFF	Fast Flash	-	Indicates that the module has detected a system error.
Regular Flash	OFF	-	Indicates that the firmware is being updated.
Regular Flash	ON	-	Indicates that a module mismatch is detected.
Single Flash	OFF	-	Indicates that the module is energized and not configured.
Operational state			
ON	OFF	-	Indicates that the module is energized, configured and operational.
ON	-	ON	Indicates that the corresponding output channel is activated.
ON	-	OFF	Indicates that the corresponding output channel is deactivated.
ON	Regular Flash	OFF	Indicates one of the following: <ul style="list-style-type: none"> • 24 Vdc field power error detection. • Sensor power supply error detection.
ON	Regular Flash	Regular Flash	Indicates that a short circuit error is detected.

The following graphic depicts the system status of LEDs during module operation:

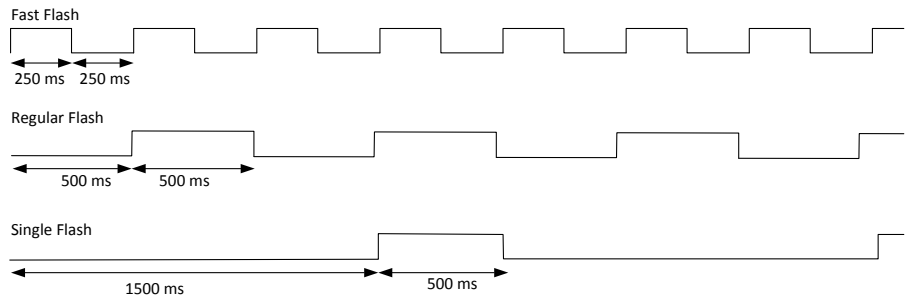

NTSDDO0802 Characteristics

Overview

This section provides a general description of the characteristics of the module.

⚠ WARNING
UNINTENDED EQUIPMENT OPERATION
Do not exceed any of the rated values specified in the environmental and electrical characteristics tables.
Failure to follow these instructions can result in death, serious injury, or equipment damage.

For more information on environmental characteristics, refer to Modicon Edge I/O - System Planning and Installation Guide.

Dimensions

The following figure presents the external dimensions of the assembled module:

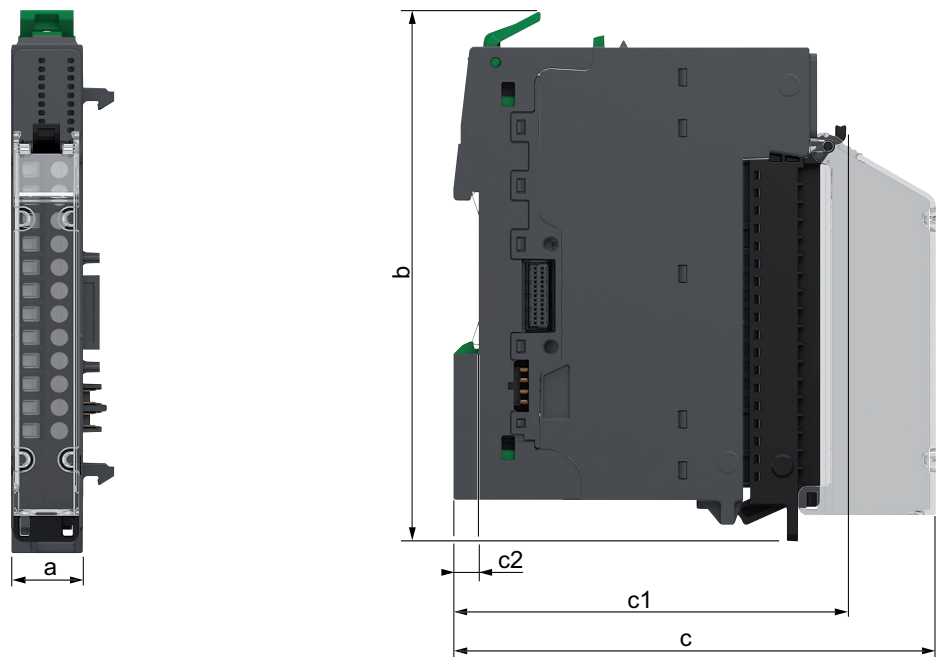

- a:** 15 mm (0.59 in)
- b:** 116.6 mm (4.57 in)
- c:** 107.5 mm (4.21 in)
- c1:** 88.2 mm (3.46 in)
- c2:** 5.6 mm (0.2 in)

Weight

- NTSDDO0802: 48 g (1.69 oz)
- NTSDDO0802K: 72 g (2.54 oz)

General Characteristics

The following table describes the general characteristics of the NTSDDO0802 output module:

Characteristics		Value
Output compatibility		1-wire
Field power supplied voltage requirements		From a 24 Vdc external power supply
Power supplied voltage range		20.4...28.8 Vdc
Bus current consumption		33.6 mA
Field current consumption for actuators, per module		0 mA
Power dissipation		1.67 W
Maximum cable length	Shielded	1,000 m (3,280 ft)
	Unshielded	600 m (1,968 ft)
Isolation voltage	Between channels	-
	Between groups	-
	Between channel and bus	1,500 Vac
	Between channel and functional earth ground	1,500 Vac
Hot swap supported		Yes
Operating ambient temperature derating		No derating

Output Characteristics

The table below describes the output characteristics of the NTSDDO0802 output module:

Characteristics		Value
Output type		Transistor
Output wiring mode		1-wire
Output current	Channel current	2 A
	Group current	4 A
	Module current	8 A
Minimum switching current		-
Maximum switching frequency		1 kHz for resistive load, 0.5 / LI ² Hz
Response time on output	Logic state 1 to logic state 0	110 µs maximum
	Logic state 0 to logic state 1	90 µs maximum
OFF-state leakage/channel		< 0.1 µA
ON-state drop/channel		< 0.25 Vdc
Paralleling of outputs	For redundant control of load	Yes (maximum 2)
Output protection	Overload	Yes
	Reverse polarity	Yes, transient-voltage-suppression on output
	Short circuit	Yes
Output diagnostic		<ul style="list-style-type: none"> Power supply monitoring (under voltage, power absent) Short circuit and overload

NTSDDO0802 Wiring

Wiring Rules

For more information on the wiring, refer to Modicon Edge I/O - System Planning and Installation Guide.

Wiring Diagram

Each group of inputs requires an external 24 Vdc power supply with a 4 A fuse.

⚠ WARNING
UNINTENDED EQUIPMENT OPERATION
Use the sensor and actuator power supply only for supplying power to sensors or actuators connected to the module.
Failure to follow these instructions can result in death, serious injury, or equipment damage.

The following figure illustrates an example of 2-/3-wire connection outputs with and external power supply:

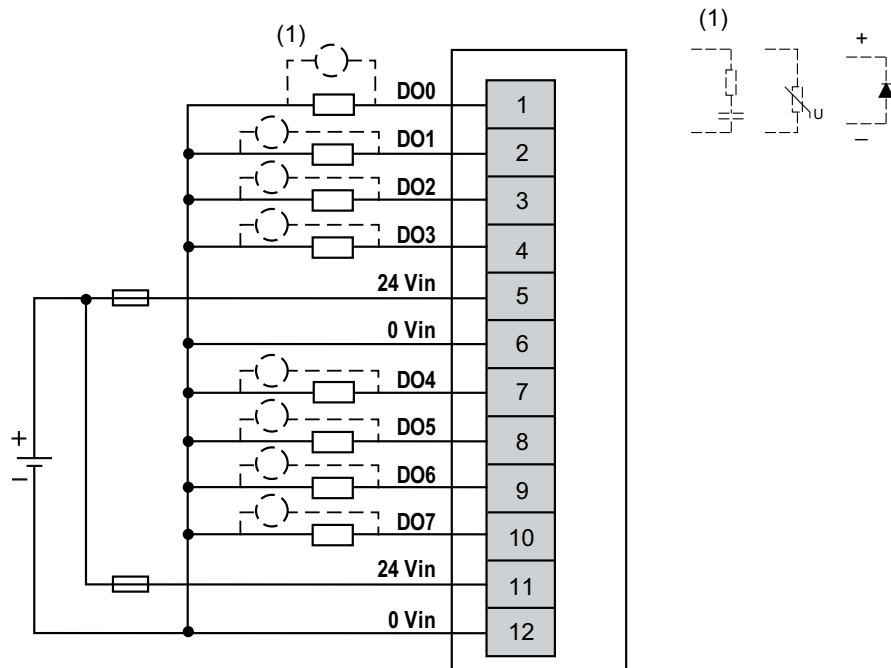

External Fuse: Type F, 4 A, 24 Vdc is mandatory and must be chosen in compliance with IEC60269 standard.

NTSDDO0802 Parameters

Parameters Description

Configurable Parameters

The following table presents the configurable parameters for the NTSDDO0802 module:

Displayed Name <i>Parameter Name</i>	Value	Data type	Description
Device Mode <i>DeviceMode</i>	0: Normal * 1: Optional 2: Virtual reserved	ENUM	Allows you to select the device mode: <ul style="list-style-type: none"> • Normal: The module is part of the software configuration and is physically connected in the cluster. • Optional: The module is part of the software configuration. A dummy module or the configured module must be physically installed in the cluster. Whether either module is present does not cause a configuration error to be detected. • Virtual reserved: The module is part of the software configuration. A dummy module must be physically installed in the cluster. If the virtual module is physically installed in the cluster, a configuration error is detected.
Rearming Output Mode <i>RearmOutputMode</i>	0: Latched Off 1: Auto Recovery *	ENUM	Allows you to select the rearming mode for an output channel which is latched off due to a detected error. Two modes are available: <ul style="list-style-type: none"> • Latched Off: The channel is rearmed if the cause of the error is no longer present, and a rising edge on RearmOutputCmd is applied. • Auto Recovery: the output channel is rearmed automatically if the cause of the error is no longer present for a predefined delay.
* Parameter default value			

The following table presents the configurable parameters for the channels of the NTSDDO0802 module:

Displayed Name <i>Parameter Name</i>	Value	Data type	Description
Channel Enabled <i>ChannelEnable</i> ⁽¹⁾	TRUE * FALSE	BOOL	Determines whether a channel is enabled or disabled.
Fallback Mode <i>OutputFallbackMode</i>	0: Fallback Value * 1: Maintain	ENUM	Allows you to select the behavior for the output in case of a communication interruption: <ul style="list-style-type: none"> • Fallback Value: Sets the output at the configured Predefined Fallback Value value. • Maintain: The output remains in its present state.
Predefined Fallback Value <i>OutputFallbackValue</i>	0 * 1	ENUM	Determines the state for the output in case of a communication interruption and Fallback Mode parameter is set to Predefined Fallback Value .
* Parameter default value			
⁽¹⁾ Online modification is allowed.			

Implicit Data

The following table presents the input implicit data for the module:

Parameter Name	Value	Data type Size in bytes R/W	Description
GCS	0...255	BYTE 1 R/-	Group Cyclic Status Bit 0: Data quality Bit 1: General module status Bit 2: I/O status Bit 3: Receive status Bit 4: Output status Bit 5: Advisory status Bit 6: N/A Bit 7: Data freshness NOTE: For more information, refer to Modicon Edge I/O - Diagnostic Data - User Guide.
ChannelHealth0_7 ⁽¹⁾	0...255	BYTE 1 R/-	Bit 0...7 = Status of channel 0...7 <ul style="list-style-type: none"> Bit = FALSE: Channel is invalid or not present. Bit = TRUE: Channel is valid or disabled.

⁽¹⁾ This parameter is not part of the implicit data if the optimized I/O profile is selected.

The following table presents the output implicit data for the module:

Parameter Name	Value	Data type Size in bytes R/W	Description
RearmOutputCmd	TRUE FALSE	BOOL R/W	If the Rearming Output Mode parameter is set to Latched Off and the cause of the detected error is no longer present, then on a rising edge, it rearms the output channels.
QValue0_7	0...255	BYTE 1 R/W	Value of the output channels (Bit field). Bit 0...7 = Value of channel 0...7 NOTE: Unused bits are reserved.

Explicit Data

The following table presents the explicit data for the channels of the module:

Parameter Name	Value	Data type Size in bytes R/W	Description
ChannelFault	0...255	BYTE R/-	Provides the following detected error on the channel: Bit 1: Short circuit error detected Bit 2: External power supply error detected NOTE: Unused bits are reserved.
QValue	TRUE = Channel is in logic state 1 FALSE = Channel is in logic state 0	BOOL R/W	Value of the output channel.

NTSDDO0802X Discrete Output Module, 8 Outputs, 24 Vdc, 500 mA, Source, Protected, 1-/2-wire

What's in This Chapter

NTSDDO0802X Presentation.....	187
NTSDDO0802X Characteristics	191
NTSDDO0802X Wiring	194
NTSDDO0802X Parameters	195

NTSDDO0802X Presentation

Main Characteristics

The following table describes the main characteristics of the NTSDDO0802X output module:

Main Characteristics	Value
Product or component type	Discrete DC output module
Number of output channels	8
Groups of output channels	1 group of 8 channels non isolated
Output logic type	Source
Output voltage	24 Vdc
Operating mode	Synchronous and isochronous

Purchasing Information

The following figure shows the elements of the Modicon Edge I/O NTS NTSDDO0802X output modules:

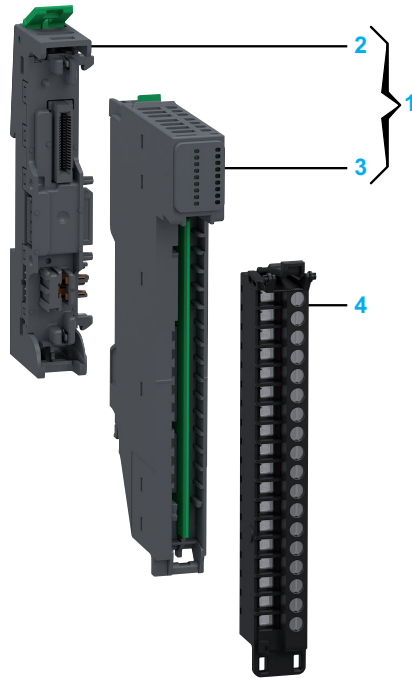

Number	Reference	Description
1	NTSDDO0802XK	Base + Module (kit) NOTE: The module and its corresponding base can be purchased as a kit.
2	NTSXBA0100H	Spare Base, 1 Slot, for Input/Output Common or Expert Module, Hardened
3	NTSDDO0802X	Discrete Output Module, 8 Outputs, 24 Vdc, 500 mA, Source, Protected, 1-/2-wire
4	NTSXTB18200XH	Spring Terminal Block, 18 Points, 5 mm Pitch, Without Cover, use on High Height Module (X), Hardened
	NTSXTB18201XH	Spring Terminal Block, 18 Points, 5 mm Pitch, With Cover, use on High Height Module (X), Hardened
	NTSXTB18000XH	Screw Terminal Block, 18 Points, 5 mm Pitch, Without Cover, use on High Height Module (X), Hardened
	NTSXTB18001XH	Screw Terminal Block, 18 Points, 5 mm Pitch, With Cover, use on High Height Module (X), Hardened
		NOTE: The terminal blocks are purchased separately.

NOTE: For more information on accessories and spare parts, refer to Modicon Edge I/O - System Planning and Installation Guide.

Physical Description

The following figure presents the elements of the module:

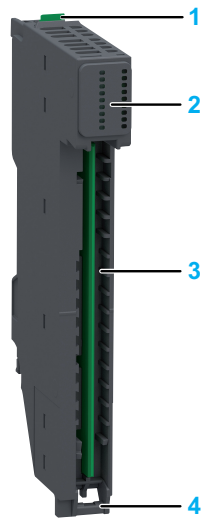

- 1: Release button for disengaging the module from the base
- 2: Status LEDs
- 3: Slot for the terminal block
- 4: Hinge for the terminal block installation

Status LEDs

The following figure presents the NTSDDO0802X status LEDs:

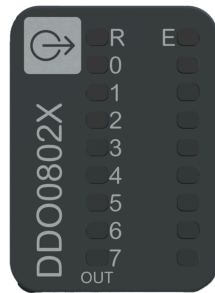

The following table describes the status of LEDs:

R (Green)	E (Red)	OUT0...7 (Green)	Description
Initialization and non-operational states			
OFF	OFF	OFF	Indicates that the module is not energized.
OFF	Fast Flash	-	Indicates that the module has detected a system error.
Regular Flash	OFF	-	Indicates that the firmware is being updated.
Regular Flash	ON	-	Indicates that a module mismatch is detected.
Single Flash	OFF	-	Indicates that the module is energized and not configured.
Operational state			
ON	OFF	-	Indicates that the module is energized, configured and operational.
ON	-	ON	Indicates that the corresponding output channel is activated.
ON	-	OFF	Indicates that the corresponding output channel is deactivated.
ON	Regular Flash	OFF	Indicates one of the following: <ul style="list-style-type: none"> • 24 Vdc field power error detection. • Sensor power supply error detection.
ON	Regular Flash	Regular Flash	Indicates that a short circuit error is detected.

The following graphic depicts the system status of LEDs during module operation:

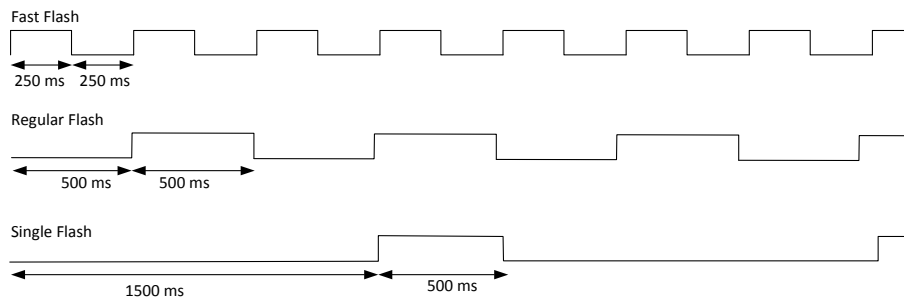

NTSDDO0802X Characteristics

Overview

This section provides a general description of the characteristics of the module.

⚠ WARNING
UNINTENDED EQUIPMENT OPERATION
Do not exceed any of the rated values specified in the environmental and electrical characteristics tables.
Failure to follow these instructions can result in death, serious injury, or equipment damage.

For more information on environmental characteristics, refer to Modicon Edge I/O - System Planning and Installation Guide.

Dimensions

The following figure presents the external dimensions of the assembled module:

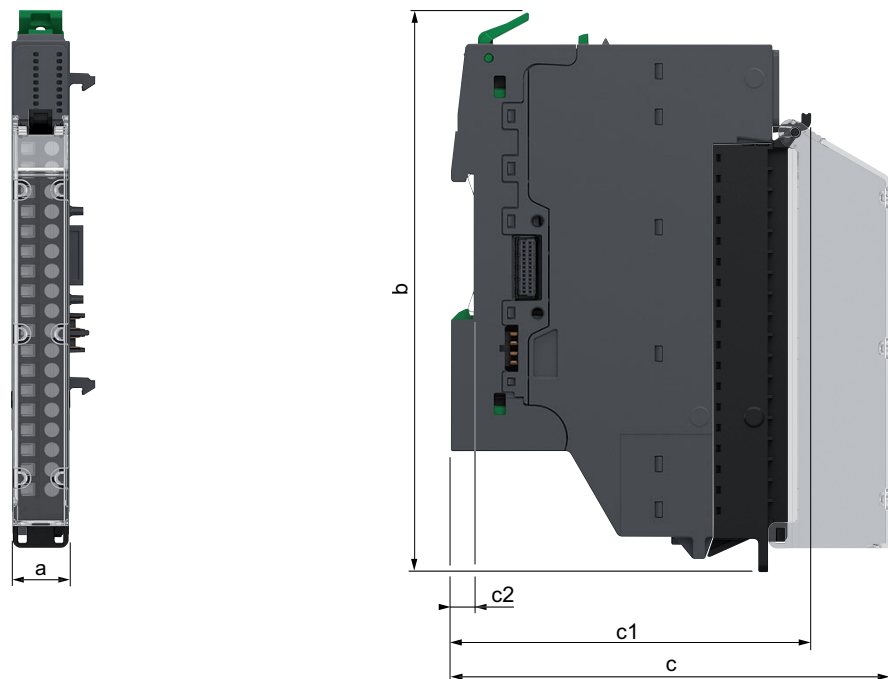

- a:** 15 mm (0.59 in)
- b:** 137.6 mm (5.39 in)
- c:** 107.5 mm (4.21 in)
- c1:** 88.2 mm (3.46 in)
- c2:** 5.6 mm (0.2 in)

Weight

- NTSDDO0802X: 49 g (1.73 oz)
- NTSDDO0802XK: 78 g (2.76 oz)

General Characteristics

The following table describes the general characteristics of the NTSDDO0802X output module:

Characteristics		Value
Output compatibility		1-/2-wire
Field power supplied voltage requirements		From the 24 Vdc field power
Power supplied voltage range		20.4...28.8 Vdc
Bus current consumption		33.6 mA
Field current consumption for actuators, per module		4,004.3 mA
Power dissipation		2.00 W
Maximum cable length	Shielded	600 m (1,968 ft)
	Unshielded	600 m (1,968 ft)
Isolation voltage	Between channels	-
	Between groups	-
	Between channel and bus	1,500 Vac
	Between channel and functional earth ground	1,500 Vac
Hot swap supported		Yes
Operating ambient temperature derating		No derating
Module overload and short circuit protection		Yes, with eFuse. NOTE: When in shutdown following the detection of an overload or short circuit error, the 24 Vdc field power must be power cycled after you have resolved the source of the error.

Output Characteristics

The table below describes the output characteristics of the NTSDDO0802X output module:

Characteristics		Value
Output type		Transistor
Output wiring mode		1-/2-wire
Output current	Channel current	500 mA
	Module current	4 A
Minimum switching current		None
Maximum switching frequency		1 kHz for resistive load, 0.5 / LI ² Hz
Response time on output	Logic state 1 to logic state 0	110 μs maximum
	Logic state 0 to logic state 1	90 μs maximum
OFF-state leakage/channel		< 0.1 μA
ON-state drop/channel		< 0.1 Vdc
Paralleling of outputs	For redundant control of load	Yes (maximum 2)
Output protection	Overload	Yes
	Reverse polarity	Yes, transient-voltage-suppression on output
	Short circuit	Yes
Output diagnostic		<ul style="list-style-type: none"> Power supply monitoring (under voltage, power absent) Short circuit and overload⁽¹⁾
⁽¹⁾ The monitoring of outputs is realized by pair of subsequent outputs: DO0/DO1, DO2/DO3...DO06/DO07. For more information about the monitoring of outputs, refer to Short Circuit Diagnostic and Recovery Methodology, page 289.		

NTSDDO0802X Wiring

Wiring Rules

For more information on the wiring, refer to Modicon Edge I/O - System Planning and Installation Guide.

Wiring Diagram

The following figure illustrates an example of 2-wire connection outputs:

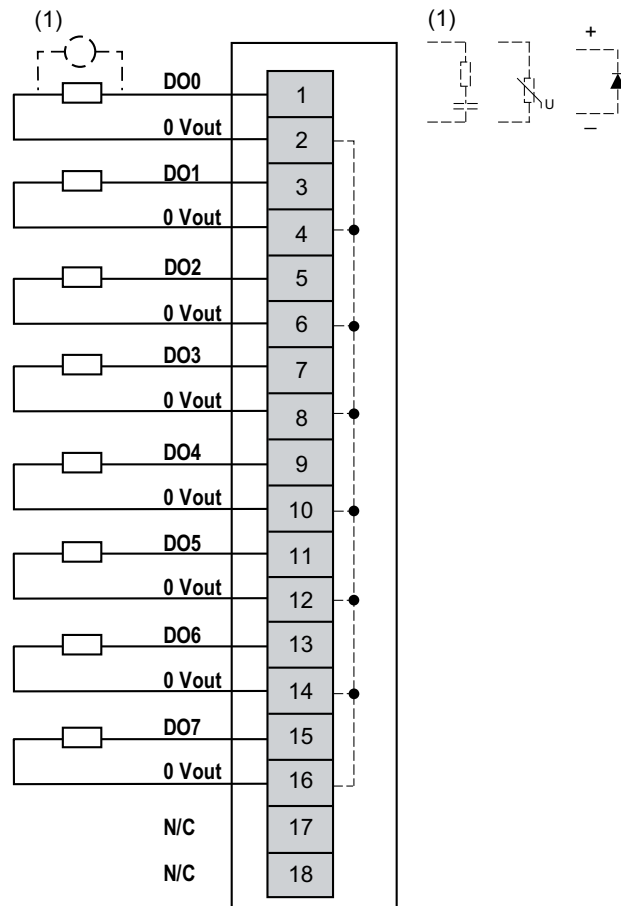

N/C: No Connection

⚠ WARNING
UNINTENDED EQUIPMENT OPERATION
Do not connect wires to unused terminals and/or terminals indicated as “No Connection (N/C)”.
Failure to follow these instructions can result in death, serious injury, or equipment damage.

NTSDDO0802X Parameters

Parameters Description

Configurable Parameters

The following table presents the configurable parameters for the NTSDDO0802X module:

Displayed Name <i>Parameter Name</i>	Value	Data type	Description
Device Mode <i>DeviceMode</i>	0: Normal * 1: Optional 2: Virtual reserved	ENUM	Allows you to select the device mode: <ul style="list-style-type: none"> • Normal: The module is part of the software configuration and is physically connected in the cluster. • Optional: The module is part of the software configuration. A dummy module or the configured module must be physically installed in the cluster. Whether either module is present does not cause a configuration error to be detected. • Virtual reserved: The module is part of the software configuration. A dummy module must be physically installed in the cluster. If the virtual module is physically installed in the cluster, a configuration error is detected.
Rearming Output Mode <i>RearmOutputMode</i>	0: Latched Off 1: Auto Recovery *	ENUM	Allows you to select the rearming mode for an output channel which is latched off due to a detected error. Two modes are available: <ul style="list-style-type: none"> • Latched Off: The channel is rearmed if the cause of the error is no longer present, and a rising edge on RearmOutputCmd is applied. • Auto Recovery: The output channel is rearmed automatically if the cause of the error is no longer present for a predefined delay.
* Parameter default value			

The following table presents the configurable parameters for the channels of the NTSDDO0802X module:

Displayed Name <i>Parameter Name</i>	Value	Data type	Description
Channel Enabled <i>ChannelEnable</i> ⁽¹⁾	TRUE * FALSE	BOOL	Determines whether a channel is enabled or disabled.
Fallback Mode <i>OutputFallbackMode</i>	0: Fallback Value * 1: Maintain	ENUM	Allows you to select the behavior for the output in case of a communication interruption: <ul style="list-style-type: none"> • Fallback Value: Sets the output at the configured Predefined Fallback Value value. • Maintain: The output remains in its present state.
Predefined Fallback Value <i>OutputFallbackValue</i>	0 * 1	ENUM	Determines the state for the output in case of a communication interruption and Fallback Mode parameter is set to Predefined Fallback Value .
* Parameter default value			
⁽¹⁾ Online modification is allowed.			

Implicit Data

The following table presents the input implicit data for the module:

Parameter Name	Value	Data type Size in bytes R/W	Description
GCS	0...255	BYTE 1 R/-	Group Cyclic Status Bit 0: Data quality Bit 1: General module status Bit 2: I/O status Bit 3: Receive status Bit 4: Output status Bit 5: Advisory status Bit 6: N/A Bit 7: Data freshness NOTE: For more information, refer to Modicon Edge I/O - Diagnostic Data - User Guide.
ChannelHealth0_7 ⁽¹⁾	0...255	BYTE 1 R/-	Bit 0...7 = Status of channel 0...7 <ul style="list-style-type: none"> • Bit = FALSE: Channel is invalid or not present. • Bit = TRUE: Channel is valid or disabled.

⁽¹⁾ This parameter is not part of the implicit data if the optimized I/O profile is selected.

The following table presents the output implicit data for the module:

Parameter Name	Value	Data type Size in bytes R/W	Description
RearmOutputCmd	TRUE FALSE	BOOL R/W	If the Rearming Output Mode parameter is set to Latched Off and the cause of the detected error is no longer present, then on a rising edge, it rearms the output channels.
QValue0_7	0...255	BYTE 1 R/W	Value of the output channels (Bit field). Bit 0...7 = Value of channel 0...7 NOTE: Unused bits are reserved.

Explicit Data

The following table presents the explicit data for the channels of the module:

Parameter Name	Value	Data type Size in bytes R/W	Description
ChannelFault	0...255	BYTE R/-	Provides the following detected error on the channel: Bit 1: Short circuit error detected Bit 4: Internal power supply error detected NOTE: Unused bits are reserved.
QValue	TRUE = Channel is in logic state 1 FALSE = Channel is in logic state 0	BOOL R/W	Value of the output channel.

NTSDDO1602 Discrete Output Module, 16 Outputs, 24 Vdc, 500 mA, Source, Protected, 1-wire

What's in This Chapter

NTSDDO1602 Presentation	197
NTSDDO1602 Characteristics	201
NTSDDO1602 Wiring	204
NTSDDO1602 Parameters	206

NTSDDO1602 Presentation

Main Characteristics

The following table describes the main characteristics of the NTSDDO1602 output module:

Main Characteristics	Value
Product or component type	Discrete DC output module
Number of output channels	16
Groups of output channels	1 group of 16 channels non isolated
Output logic type	Source
Output voltage	24 Vdc
Operating mode	Synchronous and isochronous

Purchasing Information

The following figure shows the elements of the Modicon Edge I/O NTS NTSDDO1602 output module:

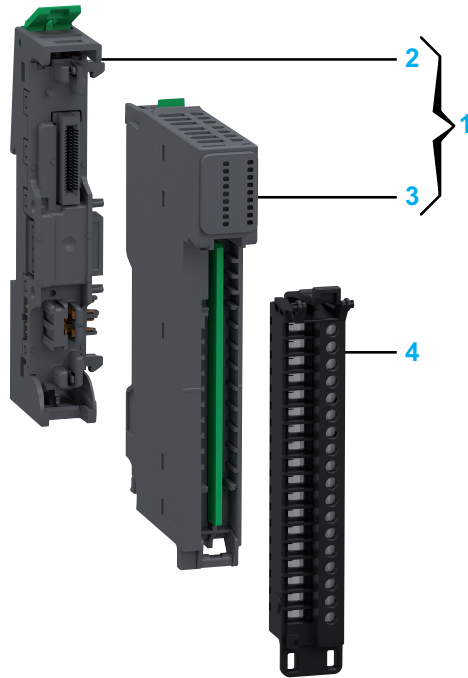

Number	Reference	Description
1	NTSDDO1602K	Base + Module (kit) NOTE: The module and its corresponding base can be purchased as a kit.
2	NTSXBA0100H	Spare Base, 1 Slot, for Input/Output Common or Expert Module, Hardened
3	NTSDDO1602	Discrete Output Module, 16 Outputs, 24 Vdc, 500 mA, Source, Protected, 1-wire
4	NTSXTB18200H	Spring Terminal Block, 18 Points, 3.81 mm Pitch, Without Cover, use on Low Height Module, Hardened
	NTSXTB18201H	Spring Terminal Block, 18 Points, 3.81 mm Pitch, With Cover, use on Low Height Module, Hardened
	NTSXTB18000H	Screw Terminal Block, 18 Points, 3.81 mm Pitch, Without Cover, use on Low Height Module, Hardened
	NTSXTB18001H	Screw Terminal Block, 18 Points, 3.81 mm Pitch, With Cover, use on Low Height Module, Hardened
		NOTE: The terminal blocks are purchased separately.

NOTE: For more information on accessories and spare parts, refer to Modicon Edge I/O - System Planning and Installation Guide.

Physical Description

The following figure presents the elements of the module:

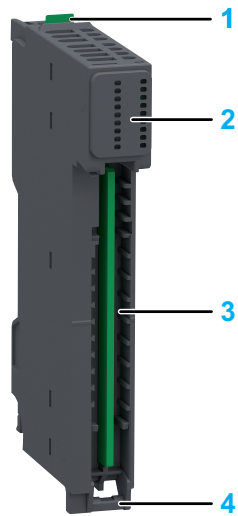

- 1: Release button for disengaging the module from the base
- 2: Status LEDs
- 3: Slot for the terminal block
- 4: Hinge for the terminal block installation

Status LEDs

The following figure presents the NTSDDO1602 status LEDs:

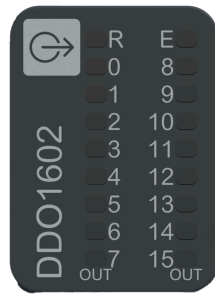

The following table describes the status of LEDs:

R (Green)	E (Red)	OUT0...15 (Green)	Description
Initialization and non-operational states			
OFF	OFF	OFF	Indicates that the module is not energized.
OFF	Fast Flash	-	Indicates that the module has detected a system error.
Regular Flash	OFF	-	Indicates that the firmware is being updated.
Regular Flash	ON	-	Indicates that a module mismatch is detected.
Single Flash	OFF	-	Indicates that the module is energized and not configured.
Operational state			
ON	OFF	-	Indicates that the module is energized, configured and operational.
ON	-	ON	Indicates that the corresponding output channel is activated.
ON	-	OFF	Indicates that the corresponding output channel is deactivated.
ON	Regular Flash	OFF	Indicates one of the following: <ul style="list-style-type: none"> 24 Vdc field power error detection. Sensor power supply error detection.
ON	Regular Flash	Regular Flash	Indicates that a short circuit error is detected.

The following graphic depicts the system status of LEDs during module operation:

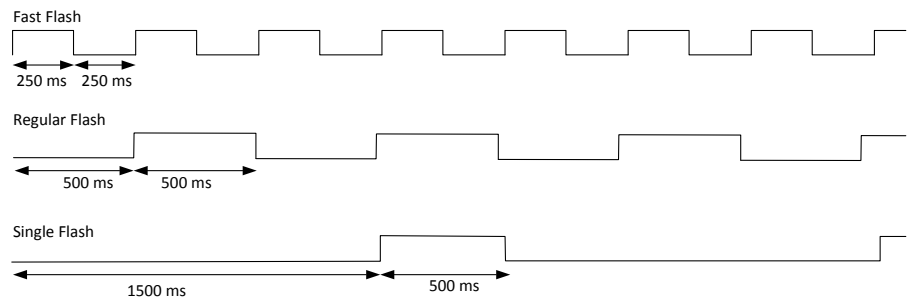

NTSDDO1602 Characteristics

Overview

This section provides a general description of the characteristics of the module.

⚠ WARNING
UNINTENDED EQUIPMENT OPERATION
Do not exceed any of the rated values specified in the environmental and electrical characteristics tables.
Failure to follow these instructions can result in death, serious injury, or equipment damage.

For more information on environmental characteristics, refer to Modicon Edge I/O - System Planning and Installation Guide.

Dimensions

The following figure presents the external dimensions of the assembled module:

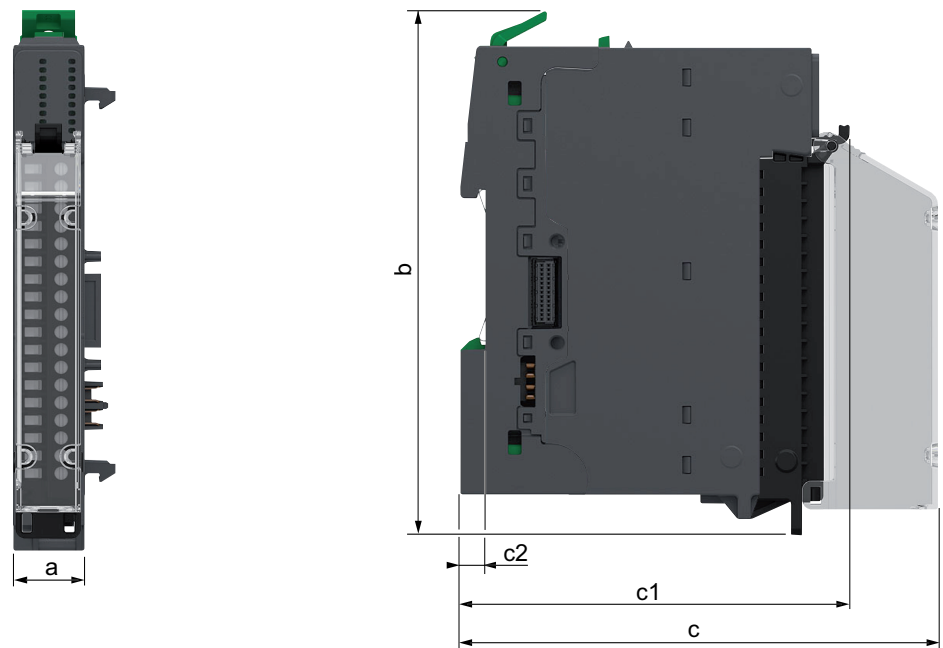

- a:** 15 mm (0.59 in)
- b:** 116.6 mm (4.57 in)
- c:** 107.5 mm (4.21 in)
- c1:** 88.2 mm (3.46 in)
- c2:** 5.6 mm (0.2 in)

Weight

- NTSDDO1602: 48 g (1.73 oz)
- NTSDDO1602K: 74 g (2.62 oz)

General Characteristics

The following table describes the general characteristics of the NTSDDO1602 output module:

Characteristics		Value
Output compatibility		1-wire
Field power supplied voltage requirements		From the 24 Vdc field power
Power supplied voltage range		20.4...28.8 Vdc
Bus current consumption		40.8 mA
Field current consumption for actuators, per module		8,007.2 mA
Power dissipation		2.65 W
Maximum cable length	Shielded	1,000 m (3,280 ft)
	Unshielded	600 m (1,968 ft)
Isolation voltage	Between channels	-
	Between groups	-
	Between channel and bus	1,500 Vac
	Between channel and functional earth ground	1,500 Vac
Hot swap supported		Yes
Operating ambient temperature derating	Correct mounting position ⁽¹⁾	8 A per module: up to 55 °C (131 °F) 7 A per module: 55...60 °C (131...140 °F)
	Accepted mounting position ⁽¹⁾	8 A per module: up to 50 °C (122 °F) 7 A per module: 50...55 °C (122...131 °F)
⁽¹⁾ For information about mounting positions, refer to Modicon Edge I/O - System Planning and Installation Guide.		

Output Characteristics

The table below describes the output characteristics of the NTSDDO1602 output module:

Characteristics		Value
Output type		Transistor
Output wiring mode		1-wire
Output current	Channel current	500 mA
	Module current	8 A
Minimum switching current		None
Maximum switching frequency		1 kHz for resistive load, 0.5 / LI ² Hz
Response time on output	Logic state 1 to logic state 0	110 μs maximum
	Logic state 0 to logic state 1	90 μs maximum
OFF-state leakage/channel		< 0.1 μA
ON-state drop/channel		< 0.1 Vdc
Paralleling of outputs	For redundant control of load	Yes (maximum 2)
Output protection	Overload	Yes
	Reverse polarity	Yes, transient-voltage-suppression on output
	Short circuit	Yes
Output diagnostic		<ul style="list-style-type: none"> Power supply monitoring (under voltage, power absent) Short circuit and overload⁽¹⁾
⁽¹⁾ The monitoring of outputs is realized by pair of subsequent outputs: DO0/DO1, DO2/DO3...DO14/DO15. For more information about the monitoring of outputs, refer to Short Circuit Diagnostic and Recovery Methodology, page 289.		

NTSDDO1602 Wiring

Wiring Rules

For more information on the wiring, refer to Modicon Edge I/O - System Planning and Installation Guide.

Wiring Diagrams

The following figure illustrates an example of 2-wire connection outputs:

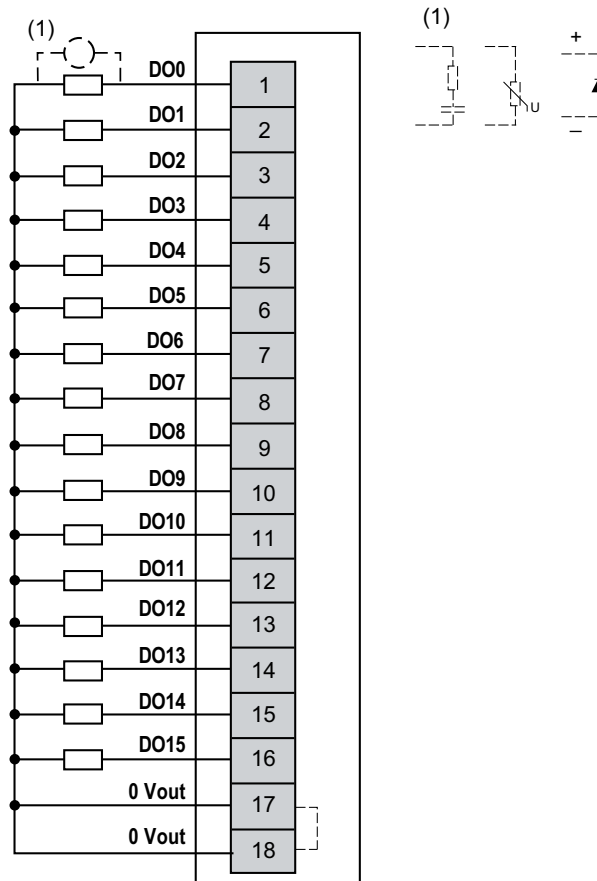

The following figure illustrates an example of 2-wire connection outputs with common module NTSPCM0016H:

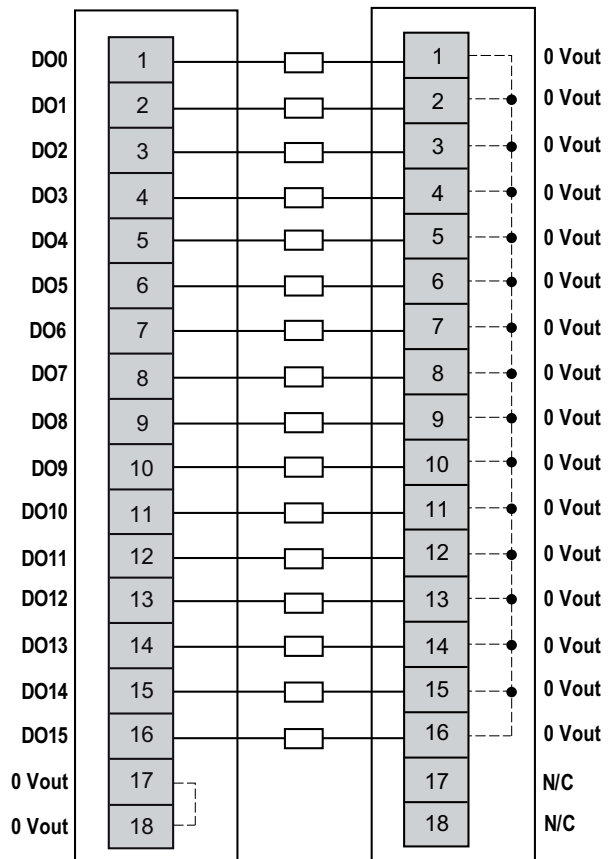

N/C: No Connection

⚠ WARNING

UNINTENDED EQUIPMENT OPERATION

Do not connect wires to unused terminals and/or terminals indicated as "No Connection (N/C)".

Failure to follow these instructions can result in death, serious injury, or equipment damage.

NTSDDO1602 Parameters

Parameters Description

Configurable Parameters

The following table presents the configurable parameters for the NTSDDO1602 module:

Displayed Name <i>Parameter Name</i>	Value	Data type	Description
Device Mode <i>DeviceMode</i>	0: Normal* 1: Optional 2: Virtual reserved	ENUM	Allows you to select the device mode: <ul style="list-style-type: none"> • Normal: The module is part of the software configuration and is physically connected in the cluster. • Optional: The module is part of the software configuration. A dummy module or the configured module must be physically installed in the cluster. Whether either module is present does not cause a configuration error to be detected. • Virtual reserved: The module is part of the software configuration. A dummy module must be physically installed in the cluster. If the virtual module is physically installed in the cluster, a configuration error is detected.
Rearming Output Mode <i>RearmOutputMode</i>	0: Latched Off 1: Auto Recovery*	ENUM	Allows you to select the rearming mode for an output channel which is latched off due to a detected error. Two modes are available: <ul style="list-style-type: none"> • Latched Off: The channel is rearmed if the cause of the error is no longer present, and a rising edge on RearmOutputCmd is applied. • Auto Recovery: The output channel is rearmed automatically if the cause of the error is no longer present for a predefined delay. For more information about the monitoring of outputs, refer to <i>Short Circuit Diagnostic and Recovery Methodology</i> , page 289.
* Parameter default value			

The following table presents the configurable parameters for the channels of the NTSDDO1602 module:

Displayed Name <i>Parameter Name</i>	Value	Data type	Description
Channel Enabled <i>ChannelEnable⁽¹⁾</i>	TRUE* FALSE	BOOL	Determines whether a channel is enabled or disabled.
Fallback Mode <i>OutputFallbackMode</i>	0: Fallback Value* 1: Maintain	ENUM	Allows you to select the behavior for the output in case of a communication interruption. Two modes are available: <ul style="list-style-type: none"> • Fallback Value: Set the output at the configured Predefined Fallback Value value. • Maintain: The output remains in its present state.
Predefined Fallback Value <i>OutputFallbackValue</i>	0* 1	ENUM	Determines the state for the output in case of a communication interruption and Fallback Mode parameter is set to Predefined Fallback Value .
* Parameter default value (1) Online modification is allowed.			

Implicit Data

The following table presents the input implicit data for the module:

Parameter Name	Value	Data type Size in bytes R/W	Description
<i>GCS</i>	0...255	BYTE 1 R/-	Group Cyclic Status Bit 0: Data quality Bit 1: General module status Bit 2: I/O status Bit 3: Receive status Bit 4: Output status Bit 5: Advisory status Bit 6: N/A Bit 7: Data freshness NOTE: For more information, refer to Modicon Edge I/O - Diagnostic Data - User Guide.
<i>ChannelHealth0_7⁽¹⁾</i>	0...255	BYTE 1 R/-	Bit 0...7 = Status of channel 0...7 <ul style="list-style-type: none"> Bit = FALSE: Channel is invalid or not present. Bit = TRUE: Channel is valid or disabled.
<i>ChannelHealth8_15⁽¹⁾</i>	0...255	BYTE 1 R/-	Bit 0...7 = Status of channel 8...15 <ul style="list-style-type: none"> Bit = FALSE: Channel is invalid or not present. Bit = TRUE: Channel is valid or disabled.

⁽¹⁾ This parameter is not part of the implicit data if the optimized I/O profile is selected.

The following table presents the output implicit data for the module:

Parameter Name	Value	Data type Size in bytes R/W	Description
<i>RearmOutputCmd</i>	TRUE FALSE	BOOL R/W	If the Rearming Output Mode parameter is set to Latched Off and the cause of the detected error is no longer present, then on a rising edge, it rearms the output channels.
<i>QValue0_7</i>	0...255	BYTE 1 R/W	Value of the output channels (Bit field). Bit 0...7 = Value of channel 0...7 NOTE: Unused bits are reserved.
<i>QValue8_15</i>	0...255	BYTE 1 R/W	Value of the output channels (Bit field). Bit 0...7 = Value of channel 8...15 NOTE: Unused bits are reserved.

Explicit Data

The following table presents the explicit data for the channels of the module:

Parameter Name	Value	Data type Size in bytes R/W	Description
<i>ChannelFault</i>	0...255	BYTE R/-	Provides the following detected error on the channel: Bit 1: Short circuit error detected Bit 4: Internal power supply error detected NOTE: Unused bits are reserved.
<i>QValue</i>	TRUE = Channel is in logic state 1 FALSE = Channel is in logic state 0	BOOL R/W	Value of the output channel.

NTSDDO1602X/NTSDDO1602XH Discrete Output Module, 16 Outputs, 24 Vdc, 500 mA, Source, Protected, 1-2-wire, Standard/Hardened

What's in This Chapter

NTSDDO1602X/NTSDDO1602XH Presentation.....	209
NTSDDO1602X/NTSDDO1602XH Characteristics	213
NTSDDO1602X/NTSDDO1602XH Wiring	216
NTSDDO1602X/NTSDDO1602XH Parameters	217

NTSDDO1602X/NTSDDO1602XH Presentation

Main Characteristics

The following table describes the main characteristics of the NTSDDO1602X/
NTSDDO1602XH output modules:

Main Characteristics	Value
Product or component type	Discrete DC output module
Number of output channels	16
Groups of output channels	2 non isolated groups of 8 channels
Output logic type	Source
Output voltage	24 Vdc
Operating mode	Synchronous and isochronous

Purchasing Information

The following figure shows the elements of the Modicon Edge I/O NTS NTSDDO1602X/NTSDDO1602XH output modules:

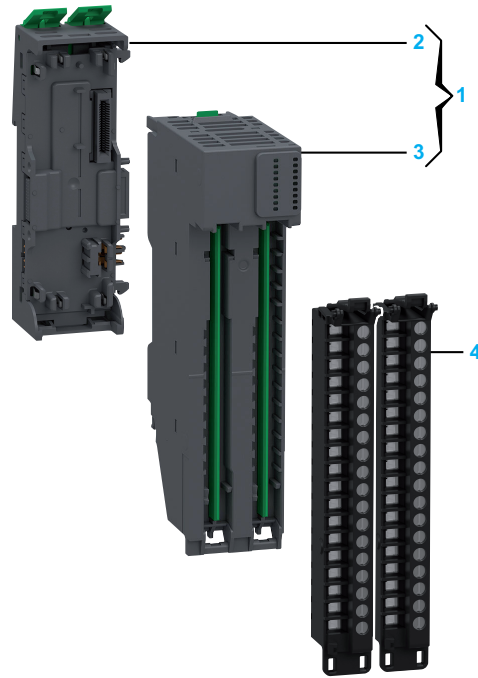

Number	Reference	Description
1	NTSDDO1602XK	Base + Module (kit) NOTE: The module and its corresponding base can be purchased as a kit.
	NTSDDO1602XHK	
2	NTSXBA0200H	Spare Base, 2 Slots, for Input/Output Common/Expert/Safety Module, Hardened
3	NTSDDO1602X	Discrete Output Module, 16 Outputs, 24 Vdc, 500 mA, Source, Protected, 1-/2-wire
	NTSDDO1602XH	Discrete Output Module, 16 Outputs, 24 Vdc, 500 mA, Source, Protected, 1-/2-wire, Hardened
4	NTSXTB18200XH	Spring Terminal Block, 18 Points, 5 mm Pitch, Without Cover, use on High Height Module (X), Hardened Spring Terminal Block, 18 Points, 5 mm Pitch, With Cover, use on High Height Module (X), Hardened Screw Terminal Block, 18 Points, 5 mm Pitch, Without Cover, use on High Height Module (X), Hardened Screw Terminal Block, 18 Points, 5 mm Pitch, With Cover, use on High Height Module (X), Hardened NOTE: The terminal blocks are purchased separately.
	NTSXTB18201XH	
	NTSXTB18000XH	
	NTSXTB18001XH	

NOTE: For more information on accessories and spare parts, refer to Modicon Edge I/O - System Planning and Installation Guide.

Physical Description

The following figure presents the elements of the module:

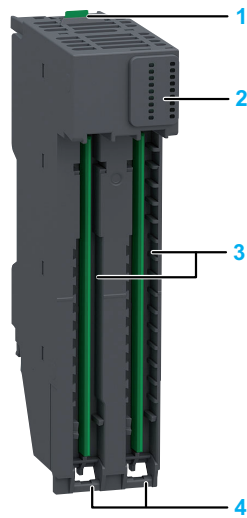

- 1: Release button for disengaging the module from the base
- 2: Status LEDs
- 3: Slot for the terminal block
- 4: Hinge for the terminal block installation

Status LEDs

The following figure presents the NTSDDO1602X/NTSDDO1602XH status LEDs:



The following table describes the status of LEDs:

R (Green)	E (Red)	OUT0...15 (Green)	Description
Initialization and non-operational states			
OFF	OFF	OFF	Indicates that the module is not energized.
OFF	Fast Flash	-	Indicates that the module has detected a system error.
Regular Flash	OFF	-	Indicates that the firmware is being updated.
Regular Flash	ON	-	Indicates that a module mismatch is detected.
Single Flash	OFF	-	Indicates that the module is energized and not configured.
Operational state			
ON	OFF	-	Indicates that the module is energized, configured and operational.
ON	-	ON	Indicates that the corresponding output channel is activated.
ON	-	OFF	Indicates that the corresponding output channel is deactivated.
ON	Regular Flash	OFF	Indicates one of the following: <ul style="list-style-type: none"> • 24 Vdc field power error detection. • Sensor power supply error detection.
ON	Regular Flash	Regular Flash	Indicates that a short circuit error is detected.

The following graphic depicts the system status of LEDs during module operation:

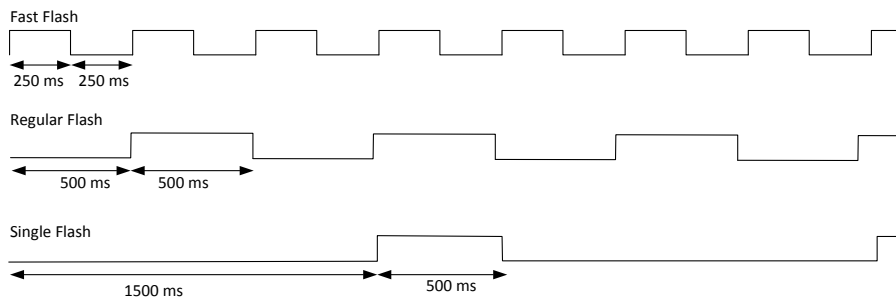

NTSDDO1602X/NTSDDO1602XH Characteristics

Overview

This section provides a general description of the characteristics of the module.

⚠ WARNING

UNINTENDED EQUIPMENT OPERATION

Do not exceed any of the rated values specified in the environmental and electrical characteristics tables.

Failure to follow these instructions can result in death, serious injury, or equipment damage.

For more information on environmental characteristics, refer to Modicon Edge I/O - System Planning and Installation Guide.

Dimensions

The following figure presents the external dimensions of the assembled module:

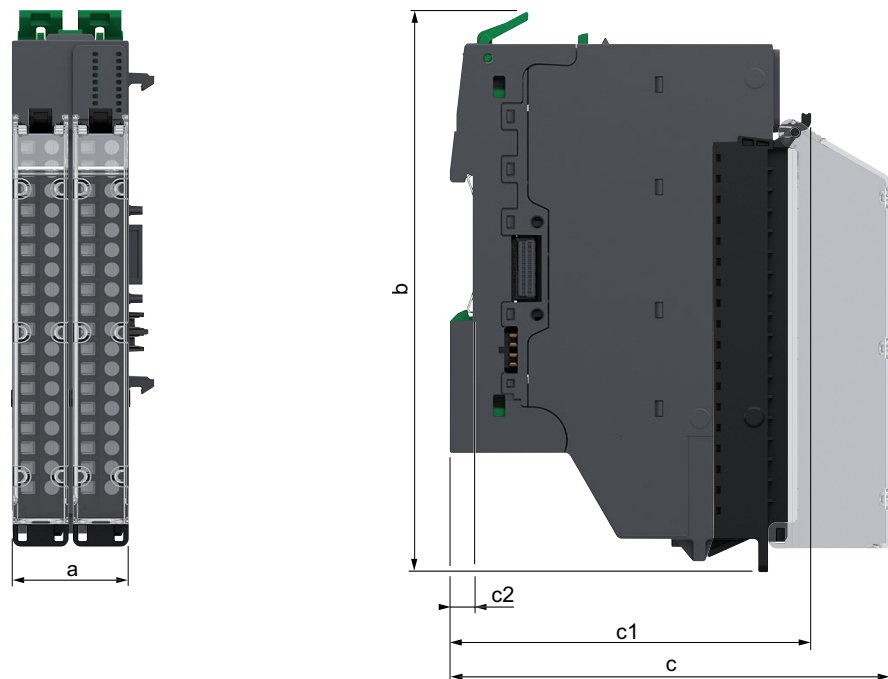

- a:** 30 mm (1.18 in)
- b:** 137.6 mm (5.39 in)
- c:** 107.5 mm (4.21 in)
- c1:** 88.2 mm (3.46 in)
- c2:** 5.6 mm (0.2 in)

Weight

- NTSDDO1602X: 85 g (3 oz)
- NTSDDO1602XK: 131 g (4.61 oz)
- NTSDDO1602XH: 85 g (3 oz)
- NTSDDO1602XHK: 131 g (4.61 oz)

General Characteristics

The following table describes the general characteristics of the NTSDDO1602X/NTSDDO1602XH output modules:

Characteristics		Value
Output compatibility		1-/2-wire
Field power supplied voltage requirements		From the 24 Vdc field power
Power supplied voltage range		20.4...28.8 Vdc
Bus current consumption		40.8 mA
Field current consumption for actuators, per module		4,008.6 mA
Power dissipation		2.68 W
Maximum cable length	Shielded	600 m (1,968 ft)
	Unshielded	600 m (1,968 ft)
Isolation voltage	Between channels	-
	Between groups	-
	Between channel and bus	1,500 Vac
	Between channel and functional earth ground	1,500 Vac
Hot swap supported		Yes
Operating ambient temperature derating		No derating
Module overload and short circuit protection		Yes, with an eFuse and the auto-retry is every 3 s. NOTE: The eFuse of the module can typically trigger when multiple channels are simultaneously in short circuit to 0 V.

Output Characteristics

The table below describes the output characteristics of the NTSDDO1602X/
 NTSDDO1602XH output modules:

Characteristics		Value
Output type		Transistor
Output wiring mode		1-/2-wire
Output current	Channel current	500 mA
	Module current	4 A
Minimum switching current		None
Maximum switching frequency		1 kHz for resistive load, 0.5 / L ² Hz
Response time on output	Logic state 1 to logic state 0	110 μs maximum
	Logic state 0 to logic state 1	90 μs maximum
OFF-state leakage/channel		< 0.1 μA
ON-state drop/channel		< 0.1 Vdc
Paralleling of outputs	For redundant control of load	Yes (maximum 2)
Output protection	Overload	Yes
	Reverse polarity	Yes, transient-voltage-suppression on output
	Short circuit	Yes
Output diagnostic		<ul style="list-style-type: none"> Power supply monitoring (under voltage, power absent) Short circuit and overload⁽¹⁾
⁽¹⁾ The monitoring of outputs is realized by pair of subsequent outputs: DO0/DO1, DO2/DO3...DO14/DO15. For more information about the monitoring of outputs, refer to Short Circuit Diagnostic and Recovery Methodology, page 289.		

NTSDDO1602X/NTSDDO1602XH Wiring

Wiring Rules

For more information on the wiring, refer to Modicon Edge I/O - System Planning and Installation Guide.

Wiring Diagram

The following figure illustrates an example of 2-wire connection outputs:

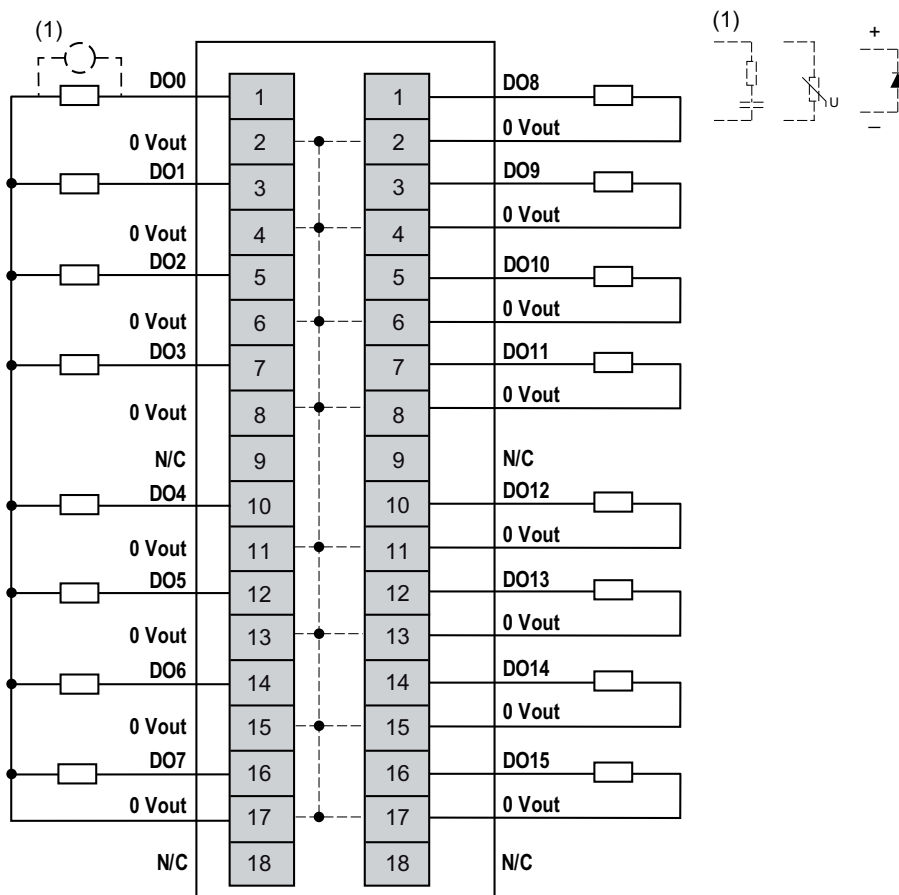

N/C: No Connection

⚠ WARNING

UNINTENDED EQUIPMENT OPERATION

Do not connect wires to unused terminals and/or terminals indicated as “No Connection (N/C)”.

Failure to follow these instructions can result in death, serious injury, or equipment damage.

NTSDDO1602X/NTSDDO1602XH Parameters

Parameters Description

Configurable Parameters

The following table presents the configurable parameters for the NTSDDO1602X/
NTSDDO1602XH modules:

Displayed Name <i>Parameter Name</i>	Value	Data type	Description
Device Mode <i>DeviceMode</i>	0: Normal * 1: Optional 2: Virtual reserved	ENUM	Allows you to select the device mode: <ul style="list-style-type: none"> Normal: The module is part of the software configuration and is physically connected in the cluster. Optional: The module is part of the software configuration. A dummy module or the configured module must be physically installed in the cluster. Whether either module is present does not cause a configuration error to be detected. Virtual reserved: The module is part of the software configuration. A dummy module must be physically installed in the cluster. If the virtual module is physically installed in the cluster, a configuration error is detected.
Rearming Output Mode <i>RearmOutputMode</i>	0: Latched Off 1: Auto Recovery *	ENUM	Allows you to select the rearming mode for an output channel which is latched off due to a detected error. Two modes are available: <ul style="list-style-type: none"> Latched Off: The channel is rearmed if the cause of the error is no longer present, and a rising edge on RearmOutputCmd is applied. Auto Recovery: The output channel is rearmed automatically if the cause of the error is no longer present for a predefined delay. For more information about the monitoring of outputs, refer to Short Circuit Diagnostic and Recovery Methodology, page 289.
* Parameter default value			

The following table presents the configurable parameters for the channels of the
NTSDDO1602X/NTSDDO1602XH modules:

Displayed Name <i>Parameter Name</i>	Value	Data type	Description
Channel Enabled <i>ChannelEnable</i> ⁽¹⁾	TRUE * FALSE	BOOL	Determines whether a channel is enabled or disabled.
Fallback Mode <i>OutputFallbackMode</i>	0: Fallback Value * 1: Maintain	ENUM	Allows you to select the behavior for the output in case of a communication interruption: <ul style="list-style-type: none"> Fallback Value: Sets the output at the configured Predefined Fallback Value value. Maintain: The output remains in its present state.
Predefined Fallback Value <i>OutputFallbackValue</i>	0 * 1	ENUM	Determines the state for the output in case of a communication interruption and Fallback Mode parameter is set to Predefined Fallback Value .
* Parameter default value (1) Online modification is allowed.			

Implicit Data

The following table presents the input implicit data for the module:

Parameter Name	Value	Data type Size in bytes R/W	Description
GCS	0...255	BYTE 1 R/-	Group Cyclic Status Bit 0: Data quality Bit 1: General module status Bit 2: I/O status Bit 3: Receive status Bit 4: Output status Bit 5: Advisory status Bit 6: N/A Bit 7: Data freshness NOTE: For more information, refer to Modicon Edge I/O - Diagnostic Data - User Guide.
ChannelHealth0_7 ⁽¹⁾	0...255	BYTE 1 R/-	Bit 0...7 = Status of channel 0...7 <ul style="list-style-type: none"> Bit = FALSE: Channel is invalid or not present. Bit = TRUE: Channel is valid or disabled.
ChannelHealth8_15 ⁽¹⁾	0...255	BYTE 1 R/-	Bit 0...7 = Status of channel 8...15 <ul style="list-style-type: none"> Bit = FALSE: Channel is invalid or not present. Bit = TRUE: Channel is valid or disabled.

⁽¹⁾ This parameter is not part of the implicit data if the optimized I/O profile is selected.

The following table presents the output implicit data for the module:

Parameter Name	Value	Data type Size in bytes R/W	Description
RearmOutputCmd	TRUE FALSE	BOOL R/W	If the Rearming Output Mode parameter is set to Latched Off and the cause of the detected error is no longer present, then on a rising edge, it rearms the output channels.
QValue0_7	0...255	BYTE 1 R/W	Value of the output channels (Bit field). Bit 0...7 = Value of channel 0...7 NOTE: Unused bits are reserved.
QValue8_15	0...255	BYTE 1 R/W	Value of the output channels (Bit field). Bit 0...7 = Value of channel 8...15 NOTE: Unused bits are reserved.

Explicit Data

The following table presents the explicit data for the channels of the module:

Parameter Name	Value	Data type Size in bytes R/W	Description
<i>ChannelFault</i>	0...255	BYTE R/-	Provides the following detected error on the channel: Bit 1: Short circuit error detected Bit 4: Internal power supply error detected NOTE: Unused bits are reserved.
<i>QValue</i>	TRUE = Channel is in logic state 1 FALSE = Channel is in logic state 0	BOOL R/W	Value of the output channel.

NTSDDO1602XA/NTSDDO1602XAH Discrete Output Module, 16 Outputs, 24 Vdc, 500 mA, Source, Protected, External Supply, 1-/2-wire, Standard/ Hardened

What's in This Chapter

NTSDDO1602XA/NTSDDO1602XAH Presentation	220
NTSDDO1602XA/NTSDDO1602XAH Characteristics	224
NTSDDO1602XA/NTSDDO1602XAH Wiring.....	227
NTSDDO1602XA/NTSDDO1602XAH Parameters.....	228

NTSDDO1602XA/NTSDDO1602XAH Presentation

Main Characteristics

The following table describes the main characteristics of the NTSDDO1602XA/
 NTSDDO1602XAH output modules:

Main Characteristics	Value
Product or component type	Discrete DC output module
Number of output channels	16
Groups of output channels	2 isolated groups of 8 non isolated channels
Output logic type	Source
Output voltage	24 Vdc
Operating mode	Synchronous and isochronous

Purchasing Information

The following figure shows the elements of the Modicon Edge I/O NTS
 NTSDDO1602XA/NTSDDO1602XAH output module:

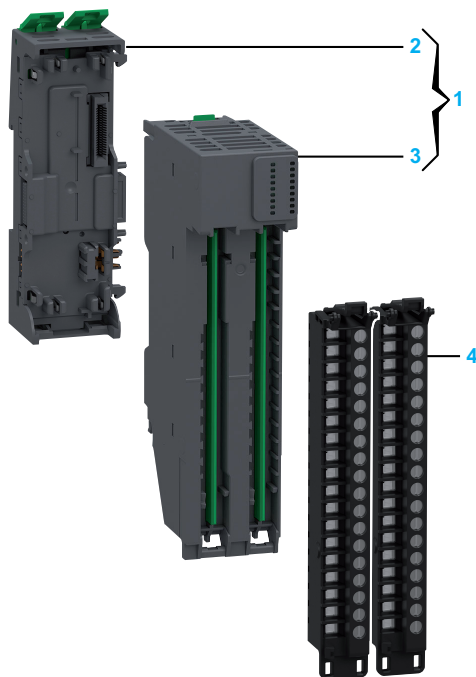

Number	Reference	Description
1	NTSDDO1602XAK NTSDDO1602XAHK	Base + Module (kit) NOTE: The module and its corresponding base can be purchased as a kit.
2	NTSXBA0200H	Spare Base, 2 Slots, for Input/Output Common/Expert/Safety Module, Hardened
3	NTSDDO1602XA NTSDDO1602XAH	Discrete Output Module, 16 Outputs, 24 Vdc, 500 mA, Source, Protected, External Supply, 1-/2-wire Discrete Output Module, 16 Outputs, 24 Vdc, 500 mA, Source, Protected, External Supply, 1-/2-wire, Hardened
4	NTSXTB18200XH NTSXTB18201XH NTSXTB18000XH NTSXTB18001XH	Spring Terminal Block, 18 Points, 5 mm Pitch, Without Cover, use on High Height Module (X), Hardened Spring Terminal Block, 18 Points, 5 mm Pitch, With Cover, use on High Height Module (X), Hardened Screw Terminal Block, 18 Points, 5 mm Pitch, Without Cover, use on High Height Module (X), Hardened Screw Terminal Block, 18 Points, 5 mm Pitch, With Cover, use on High Height Module (X), Hardened NOTE: The terminal blocks are purchased separately.

NOTE: For more information on accessories and spare parts, refer to Modicon Edge I/O - System Planning and Installation Guide.

Physical Description

The following figure presents the elements of the module:

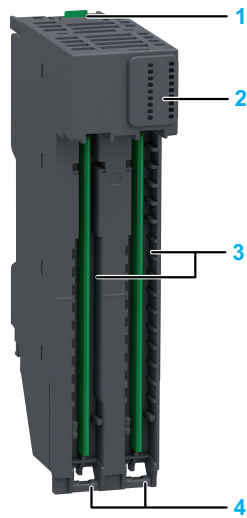

- 1: Release button for disengaging the module from the base
- 2: Status LEDs
- 3: Slot for the terminal block
- 4: Hinge for the terminal block installation

Status LEDs

The following figure presents the NTSDDO1602XA/NTSDDO1602XAH status LEDs:

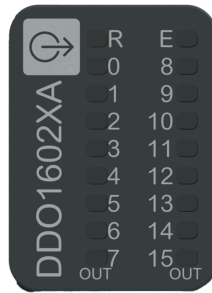

The following table describes the status of LEDs:

R (Green)	E (Red)	OUT0...15 (Green)	Description
Initialization and non-operational states			
OFF	OFF	OFF	Indicates that the module is not energized.
OFF	Fast Flash	-	Indicates that the module has detected a system error.
Regular Flash	OFF	-	Indicates that the firmware is being updated.
Regular Flash	ON	-	Indicates that a module mismatch is detected.
Single Flash	OFF	-	Indicates that the module is energized and not configured.
Operational state			
ON	OFF	-	Indicates that the module is energized, configured and operational.
ON	-	ON	Indicates that the corresponding output channel is activated.
ON	-	OFF	Indicates that the corresponding output channel is deactivated.
ON	Regular Flash	OFF	Indicates one of the following: <ul style="list-style-type: none"> • 24 Vdc field power error detection. • Sensor power supply error detection.
ON	Regular Flash	Regular Flash	Indicates that a short circuit error is detected.

The following graphic depicts the system status of LEDs during module operation:

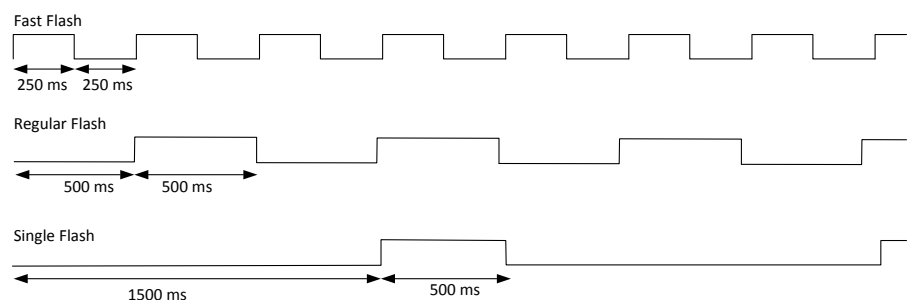

NTSDDO1602XA/NTSDDO1602XAH Characteristics

Overview

This section provides a general description of the characteristics of the module.

⚠ WARNING

UNINTENDED EQUIPMENT OPERATION

Do not exceed any of the rated values specified in the environmental and electrical characteristics tables.

Failure to follow these instructions can result in death, serious injury, or equipment damage.

For more information on environmental characteristics, refer to Modicon Edge I/O - System Planning and Installation Guide.

Dimensions

The following figure presents the external dimensions of the assembled module:

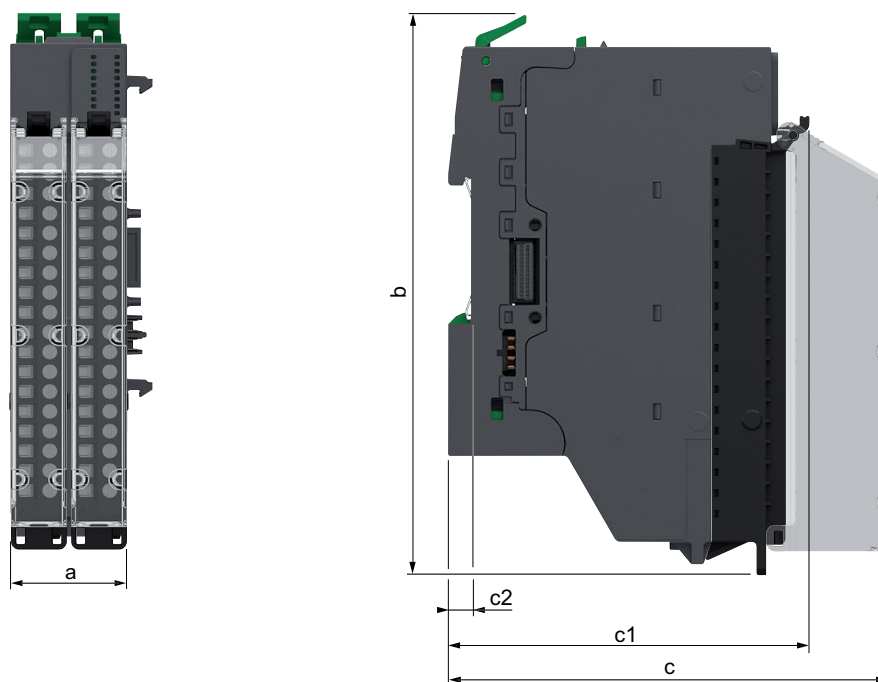

- a:** 30 mm (1.18 in)
- b:** 137.6 mm (5.39 in)
- c:** 107.5 mm (4.21 in)
- c1:** 88.2 mm (3.46 in)
- c2:** 5.6 mm (0.2 in)

Weight

- NTSDDO1602XA: 85 g (3 oz)
- NTSDDO1602XAK: 131 g (4.61 oz)
- NTSDDO1602XAH: 85 g (3 oz)
- NTSDDO1602XAHK: 131 g (4.61 oz)

General Characteristics

The following table describes the general characteristics of the NTSDDO1602XA/
 NTSDDO1602XAH output modules:

Characteristics		Value
Output compatibility		1-/2-wire
Field power supplied voltage requirements		From a 24 Vdc external power supply
Power supplied voltage range		20.4...28.8 Vdc
Bus current consumption		42.0 mA
Field current consumption for actuators, per module		0 mA
Power dissipation		2.50 W
Maximum cable length	Shielded	600 m (1,968 ft)
	Unshielded	600 m (1,968 ft)
Isolation voltage	Between channels	-
	Between groups	500 Vac
	Between channel and bus	1,500 Vac
	Between channel and functional earth ground	1,500 Vac
Hot swap supported		Yes
Operating ambient temperature derating		No derating

Output Characteristics

The table below describes the output characteristics of the NTSDDO1602XA/
NTSDDO1602XAH output modules:

Characteristics		Value
Output type		Transistor
Output wiring mode		1-/2-wire
Output current	Channel current	500 mA
	Module current	8 A
Minimum switching current		None
Maximum switching frequency		1 kHz for resistive load, 0.5 / LI ² Hz
Response time on output	Logic state 1 to logic state 0	110 μs maximum
	Logic state 0 to logic state 1	90 μs maximum
OFF-state leakage/channel		< 0.1 μA
ON-state drop/channel		< 0.1 Vdc
Paralleling of outputs	For redundant control of load	Yes from same group (maximum 2)
Output protection	Overload	Yes
	Reverse polarity	Yes, transient-voltage-suppression on output
	Short circuit	Yes
Output diagnostic		<ul style="list-style-type: none"> Power supply monitoring (power absent) Short circuit and overload⁽¹⁾
⁽¹⁾ The monitoring of outputs is realized by pair of subsequent outputs: DO0/DO1, DO2/DO3...DO14/DO15. For more information about the monitoring of outputs, refer to Short Circuit Diagnostic and Recovery Methodology, page 289.		

NTSDDO1602XA/NTSDDO1602XAH Wiring

Wiring Rules

For more information on the wiring, refer to Modicon Edge I/O - System Planning and Installation Guide.

Wiring Diagram

Each group of inputs requires an external 24 Vdc power supply with a 4 A fuse.

To maintain the isolation between groups, use independent power supplies.

⚠ WARNING
UNINTENDED EQUIPMENT OPERATION
Use the sensor and actuator power supply only for supplying power to sensors or actuators connected to the module.
Failure to follow these instructions can result in death, serious injury, or equipment damage.

The following figure illustrates an example of 1-/2-wire connection outputs with an external power supply and isolation between groups:

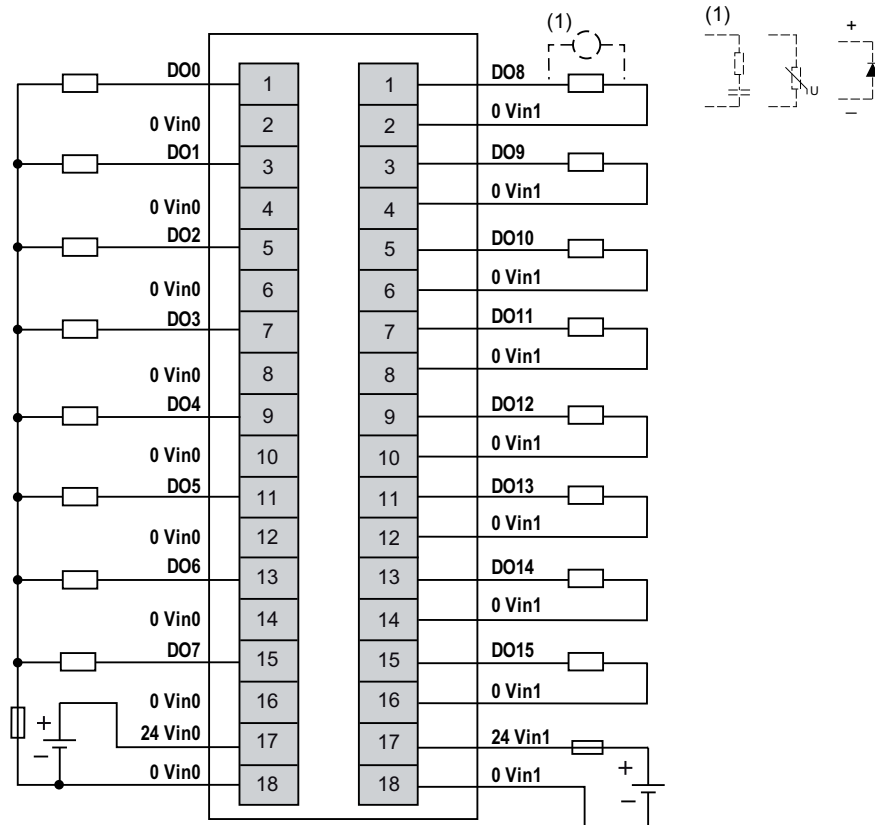

External Fuse: Type F, 4 A, 24 Vdc is mandatory and must be chosen in compliance with IEC60269 standard.

NTSDDO1602XA/NTSDDO1602XAH Parameters

Parameters Description

Configurable Parameters

The following table presents the configurable parameters for the NTSDDO1602XA/NTSDDO1602XAH modules:

Displayed Name <i>Parameter Name</i>	Value	Data type	Description
Device Mode <i>DeviceMode</i>	0: Normal* 1: Optional 2: Virtual reserved	ENUM	Allows you to select the device mode: <ul style="list-style-type: none"> • Normal: The module is part of the software configuration and is physically connected in the cluster. • Optional: The module is part of the software configuration. A dummy module or the configured module must be physically installed in the cluster. Whether either module is present does not cause a configuration error to be detected. • Virtual reserved: The module is part of the software configuration. A dummy module must be physically installed in the cluster. If the virtual module is physically installed in the cluster, a configuration error is detected.
Rearming Output Mode <i>RearmOutputMode</i>	0: Latched Off 1: Auto Recovery*	ENUM	Allows you to select the rearming mode for an output channel which is latched off due to a detected error. Two modes are available: <ul style="list-style-type: none"> • Latched Off: The channel is rearmed if the cause of the error is no longer present, and a rising edge on RearmOutputCmd is applied. • Auto Recovery: The output channel is rearmed automatically if the cause of the error is no longer present for a predefined delay. For more information about the monitoring of outputs, refer to Short Circuit Diagnostic and Recovery Methodology, page 289.
* Parameter default value			

The following table presents the configurable parameters for the channels of the NTSDDO1602XA/NTSDDO1602XAH modules:

Displayed Name <i>Parameter Name</i>	Value	Data type	Description
Channel Enabled <i>ChannelEnable⁽¹⁾</i>	TRUE* FALSE	BOOL	Determines whether a channel is enabled or disabled.
Fallback Mode <i>OutputFallbackMode</i>	0: Fallback Value* 1: Maintain	ENUM	Allows you to select the behavior for the output in case of a communication interruption: <ul style="list-style-type: none"> • Fallback Value: Sets the output at the configured Predefined Fallback Value value. • Maintain: The output remains in its present state.
Predefined Fallback Value <i>OutputFallbackValue</i>	0* 1	ENUM	Determines the state for the output in case of a communication interruption and Fallback Mode parameter is set to Predefined Fallback Value .
* Parameter default value (1) Online modification is allowed.			

Implicit Data

The following table presents the input implicit data for the module:

Parameter Name	Value	Data type Size in bytes R/W	Description
<i>GCS</i>	0...255	BYTE 1 R/-	Group Cyclic Status Bit 0: Data quality Bit 1: General module status Bit 2: I/O status Bit 3: Receive status Bit 4: Output status Bit 5: Advisory status Bit 6: N/A Bit 7: Data freshness NOTE: For more information, refer to Modicon Edge I/O - Diagnostic Data - User Guide.
<i>ChannelHealth0_7</i> ⁽¹⁾	0...255	BYTE 1 R/-	Bit 0...7 = Status of channel 0...7 <ul style="list-style-type: none"> • Bit = FALSE: Channel is invalid or not present. • Bit = TRUE: Channel is valid or disabled.
<i>ChannelHealth8_15</i> ⁽¹⁾	0...255	BYTE 1 R/-	Bit 0...7 = Status of channel 8...15 <ul style="list-style-type: none"> • Bit = FALSE: Channel is invalid or not present. • Bit = TRUE: Channel is valid or disabled.
⁽¹⁾ This parameter is not part of the implicit data if the optimized I/O profile is selected.			

The following table presents the output implicit data for the module:

Parameter Name	Value	Data type Size in bytes R/W	Description
<i>RearmOutputCmd</i>	TRUE FALSE	BOOL R/W	If the Rearming Output Mode parameter is set to Latched Off and the cause of the detected error is no longer present, then on a rising edge, it rearms the output channels.
<i>QValue0_7</i>	0...255	BYTE 1 R/W	Value of the output channels (Bit field). Bit 0...7 = Value of channel 0...7 NOTE: Unused bits are reserved.
<i>QValue8_15</i>	0...255	BYTE 1 R/W	Value of the output channels (Bit field). Bit 0...7 = Value of channel 8...15 NOTE: Unused bits are reserved.

Explicit Data

The following table presents the explicit data for the channels of the module:

Parameter Name	Value	Data type Size in bytes R/W	Description
<i>ChannelFault</i>	0...255	BYTE R/-	Provides the following detected error on the channel: Bit 1: Short circuit error detected Bit 2: External power supply error detected NOTE: Unused bits are reserved.
<i>QValue</i>	TRUE = Channel is in logic state 1 FALSE = Channel is in logic state 0	BOOL R/W	Value of the output channel.

NTSDAO0205 Discrete Output Module, 2 Outputs, 1 A, 100...240 Vac, 1-/2-/3-wire

What's in This Chapter

NTSDAO0205 Presentation	231
NTSDAO0205 Characteristics	235
NTSDAO0205 Wiring	238
NTSDAO0205 Parameters.....	239

NTSDAO0205 Presentation

Main Characteristics

The following table describes the main characteristics of the NTSDAO0205 output module:

Main Characteristics	Value
Product or component type	Discrete AC output module
Number of output channels	2
Groups of output channels	1 group of 2 channels
Output logic type	Triac
Output voltage	80...264 Vac (47...63 Hz)
Operating mode	Asynchronous

Purchasing Information

The following figure shows the elements of the Modicon Edge I/O NTS NTSDAO0205 output module:

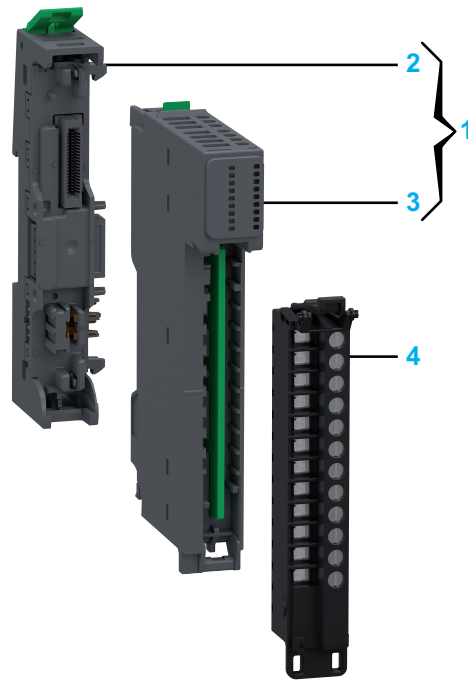

Number	Reference	Description
1	NTSDAO0205K	Base + Module (kit) NOTE: The module and its corresponding base can be purchased as a kit.
2	NTSXBA0100H	Spare Base, 1 Slot, for Input/Output Common or Expert Module, Hardened
3	NTSDAO0205	Discrete Output Module, 2 Outputs, 1 A, 100...240 Vac, 1-/2-/3-wire
4	NTSXTB12211H	Spring Terminal Block, 12 Points, 5 mm Pitch, With Cover, AC, use on Low Height Module, Hardened
	NTSXTB12011H	Screw Terminal Block, 12 Points, 5 mm Pitch, With Cover, AC, use on Low Height Module, Hardened
	NTSXTB12210H	Spring Terminal Block, 12 Points, 5 mm Pitch, Without Cover, AC, use on Low Height Module, Hardened
	NTSXTB12010H	Screw Terminal Block, 12 Points, 5 mm Pitch, Without Cover, AC, use on Low Height Module, Hardened
		NOTE: The terminal blocks are purchased separately.

NOTE: For more information on accessories and spare parts, refer to Modicon Edge I/O - System Planning and Installation Guide.

Physical Description

The following figure presents the elements of the module:

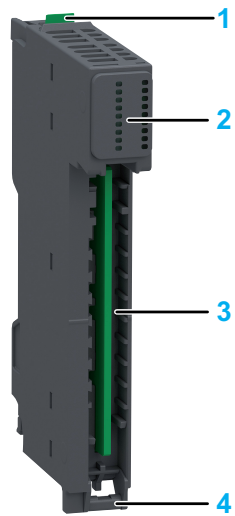

- 1: Release button for disengaging the module from the base
- 2: Status LEDs
- 3: Slot for the terminal block
- 4: Hinge for the terminal block installation

Status LEDs

The following figure presents the NTSDAO0205 status LEDs:

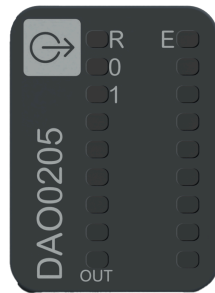

The following table describes the status of LEDs:

R (Green)	E (Red)	OUT0...1 (Green)	Description
Initialization and non-operational states			
OFF	OFF	OFF	Indicates that the module is not energized.
OFF	Fast Flash	-	Indicates that the module has detected a system error.
Regular Flash	OFF	-	Indicates that the firmware is being updated.
Regular Flash	ON	-	Indicates that a module mismatch is detected.
Single Flash	OFF	-	Indicates that the module is energized and not configured.
Operational state			
ON	OFF	-	Indicates that the module is energized, configured and operational.
ON	-	ON	Indicates that the corresponding output channel is activated.
ON	-	OFF	Indicates that the corresponding output channel is deactivated.
ON	Regular Flash	OFF	Indicates a field power supply error detection.

The following graphic depicts the system status of LEDs during module operation:

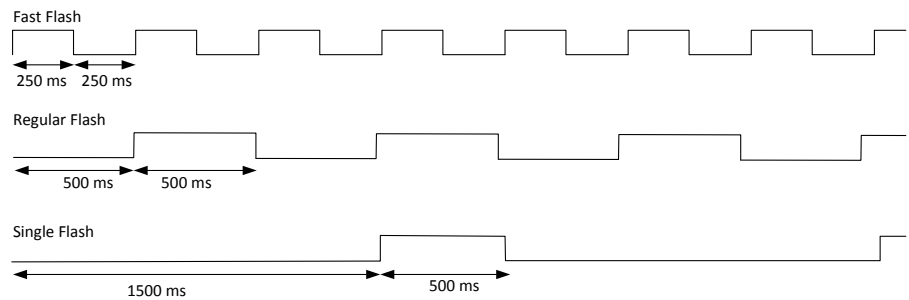

NTSDAO0205 Characteristics

Overview

This section provides a general description of the characteristics of the module.

⚠ WARNING
UNINTENDED EQUIPMENT OPERATION
Do not exceed any of the rated values specified in the environmental and electrical characteristics tables.
Failure to follow these instructions can result in death, serious injury, or equipment damage.

For more information on environmental characteristics, refer to Modicon Edge I/O - System Planning and Installation Guide.

Dimensions

The following figure presents the external dimensions of the assembled module:

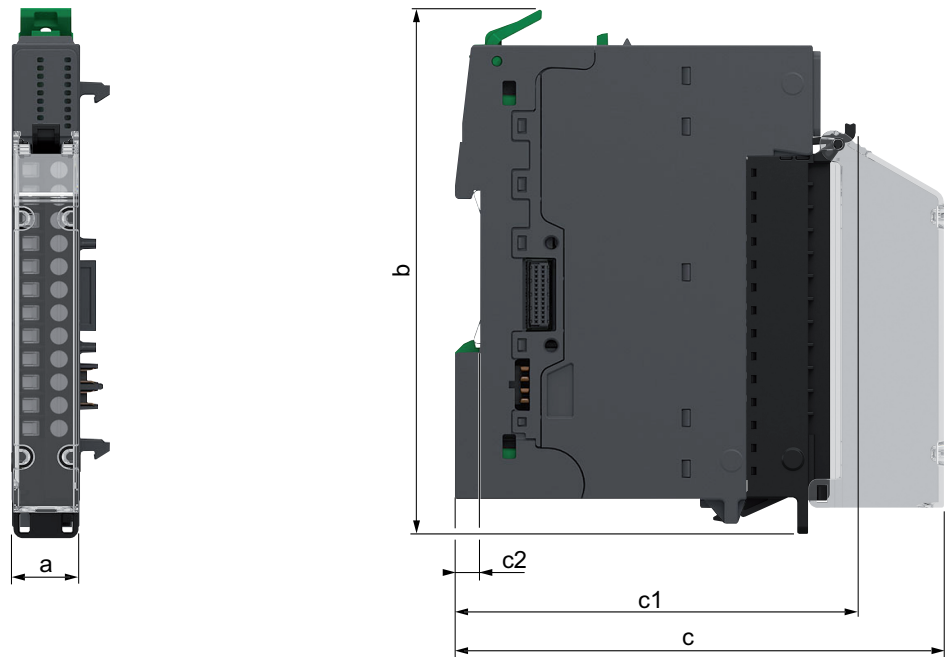

- a:** 15 mm (0.59 in)
- b:** 116.6 mm (4.57 in)
- c:** 107.5 mm (4.21 in)
- c1:** 88.2 mm (3.46 in)
- c2:** 5.6 mm (0.2 in)

Weight

- NTSDAO0205: 48 g (1.69 oz)
- NTSDAO0205K: 73 g (2.57 oz)

General Characteristics

The following table describes the general characteristics of the NTSDAO0205 output module:

Characteristics		Value
Output compatibility		1-/2-/3-wire
Field power supplied voltage requirements		From a 100...240 Vac external power supply
Power supplied voltage range		85...264 Vac (47...63 Hz)
Bus current consumption		30 mA
Field current consumption for actuators, per module		0 mA
Power dissipation		2.36 W
Maximum cable length	Shielded	200 m (656 ft)
	Unshielded	200 m (656 ft)
Isolation voltage	Between channels	-
	Between groups	-
	Between channel and bus	3,000 Vac
	Between channel and functional earth ground	3,000 Vac
Hot swap supported		Yes
Operating ambient temperature derating	Correct mounting position ⁽¹⁾	2 A per module: up to 50 °C (122 °F) 1.6 A per module: 55...60 °C (131...140 °F) 1.2 A per module: at 60 °C (140 °F)
	Accepted mounting position ⁽¹⁾	2 A per module: up to 45 °C (113 °F) 1.6 A per module: 45...50 °C (113...122 °F) 1.2 A per module: at 55 °C (131 °F)
⁽¹⁾ For information about mounting positions, refer to Modicon Edge I/O - System Planning and Installation Guide.		

Output Characteristics

The table below describes the output characteristics of the NTSDAO0205 output module:

Characteristics		Value
Output type		Triac
Output wiring mode		1-/2-/3-wire
Output current	Channel current	1 A
	Module current	2 A with a derating, page 236
Minimum switching current		5 mA
Operating frequency range		47...63 Hz
Response time on output	Logic state 1 to logic state 0	0.5 line cycles maximum
	Logic state 0 to logic state 1	0.5 line cycles maximum
Maximal OFF State Leakage /Channel		<ul style="list-style-type: none"> • 2.5 mA at 240 Vac • 2 mA at 120 Vac
Voltage drop at ON state		≤ 1.55 Vac
Paralleling of two outputs	For logic links or redundant control of load	Yes
Output protection	Over voltage	External Metal Oxide Varistor (MOV) or +RC snubber
	Short circuit	External 2 A fast blow fuse
Output diagnostic		-

NTSDAO0205 Wiring

Wiring Rules

For more information on the wiring, refer to Modicon Edge I/O - System Planning and Installation Guide.

Wiring Diagram

Each group of inputs requires an external 100...240 Vac power supply with a 5 A / 250 V fuse.

⚠ WARNING
UNINTENDED EQUIPMENT OPERATION
Use the sensor and actuator power supply only for supplying power to sensors or actuators connected to the module.
Failure to follow these instructions can result in death, serious injury, or equipment damage.

The following figure illustrates an example of 2-/3-wire connection outputs with an external power supply:

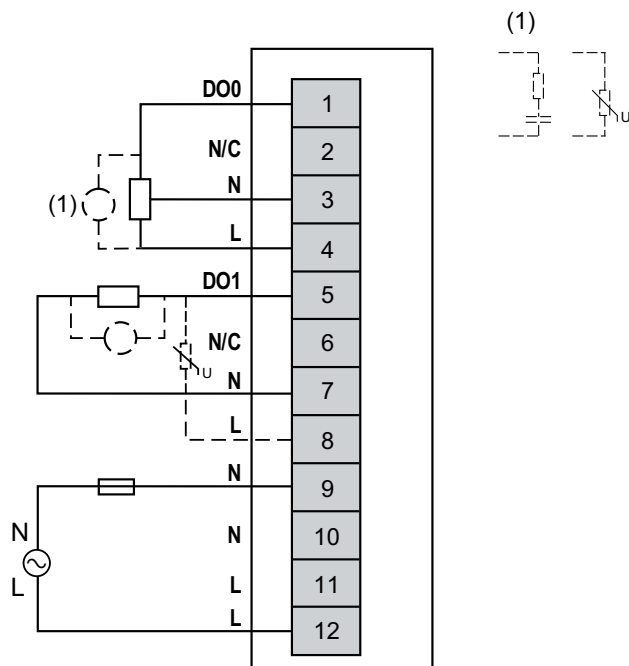

External Fuse: Type F, 5 A, 250 Vac is mandatory and must be chosen in compliance with IEC60269 standard.

N/C: No Connection

⚠ WARNING
UNINTENDED EQUIPMENT OPERATION
Do not connect wires to unused terminals and/or terminals indicated as “No Connection (N/C)”.
Failure to follow these instructions can result in death, serious injury, or equipment damage.

NTSDAO0205 Parameters

Parameters Description

Configurable Parameters

The following table presents the configurable parameters for the NTSDAO0205 module:

Displayed Name <i>Parameter Name</i>	Value	Data type	Description
Device Mode <i>DeviceMode</i>	0: Normal * 1: Optional 2: Virtual reserved	ENUM	Allows you to select the device mode: <ul style="list-style-type: none"> • Normal: The module is part of the software configuration and is physically connected in the cluster. • Optional: The module is part of the software configuration. A dummy module or the configured module must be physically installed in the cluster. Whether either module is present does not cause a configuration error to be detected. • Virtual reserved: The module is part of the software configuration. A dummy module must be physically installed in the cluster. If the virtual module is physically installed in the cluster, a configuration error is detected.
Diag Enable External Power Supply <i>DiagEnableExternalPower-Supply</i> ⁽¹⁾	FALSE TRUE *	BOOL	Enables or disables the external power supply diagnostics.
* Parameter default value (1) Online modification is allowed.			

The following table presents the configurable parameters for the channels of the NTSDAO0205 module:

Displayed Name <i>Parameter Name</i>	Value	Data type	Description
Channel Enabled <i>ChannelEnable</i> ⁽¹⁾	TRUE * FALSE	BOOL	Determines whether a channel is enabled or disabled.
Fallback Mode <i>OutputFallbackMode</i>	0: Fallback Value * 1: Maintain	ENUM	Allows you to select the behavior for the output in case of a communication interruption: <ul style="list-style-type: none"> • Fallback Value: Sets the output at the configured Predefined Fallback Value value. • Maintain: The output remains in its present state.
Predefined Fallback Value <i>OutputFallbackValue</i>	0 * 1	ENUM	Determines the state for the output in case of a communication interruption and Fallback Mode parameter is set to Predefined Fallback Value .
* Parameter default value (1) Online modification is allowed.			

Implicit Data

The following table presents the input implicit data for the module:

Parameter Name	Value	Data type Size in bytes R/W	Description
GCS	0...255	BYTE 1 R/-	Group Cyclic Status Bit 0: Data quality Bit 1: General module status Bit 2: I/O status Bit 3: Receive status Bit 4: Output status Bit 5: Advisory status Bit 6: N/A Bit 7: Data freshness NOTE: For more information, refer to Modicon Edge I/O - Diagnostic Data - User Guide.
ChannelHealth0_7 ⁽¹⁾	0...255	BYTE 1 R/-	Bit 0...7 = Status of channel 0...7 <ul style="list-style-type: none"> Bit = FALSE: Channel is invalid or not present. Bit = TRUE: Channel is valid or disabled.
⁽¹⁾ This parameter is not part of the implicit data if the optimized I/O profile is selected.			

The following table presents the output implicit data for the module:

Parameter Name	Value	Data type Size in bytes R/W	Description
QValue0_7	0...255	BYTE 1 R/W	Value of the output channels (Bit field). Bit 0...7 = Value of channel 0...7 NOTE: Unused bits are reserved.

Explicit Data

The following table presents the explicit data for the channels of the module:

Parameter Name	Value	Data type Size in bytes R/W	Description
ChannelFault	0...255	BYTE R/-	Provides the following detected error on the channel: Bit 2: External power supply error detected NOTE: Unused bits are reserved.
QValue	TRUE = Channel is in logic state 1 FALSE = Channel is in logic state 0	BOOL R/W	Value of the output channel.

NTSDAO0415/NTSDAO0415H Discrete Output Module, 4 Isolated Outputs, 2 A, 100...240 Vac, 1-/2-/3-wire, Standard/Hardened

What's in This Chapter

NTSDAO0415/NTSDAO0415H Presentation.....	241
NTSDAO0415/NTSDAO0415H Characteristics	245
NTSDAO0415/NTSDAO0415H Wiring	247
NTSDAO0415/NTSDAO0415H Parameters	249

NTSDAO0415/NTSDAO0415H Presentation

Main Characteristics

The following table describes the main characteristics of the NTSDAO0415/NTSDAO0415H output modules:

Main Characteristics	Value
Product or component type	Discrete AC output module
Number of output channels	4
Groups of output channels	4 groups of 1 channel
Output logic type	Triac
Output voltage	24...250 Vac (47...63 Hz) 5...125 Vdc
Operating mode	Asynchronous

Purchasing Information

The following figure shows the elements of the Modicon Edge I/O NTS NTSDAO0415/NTSDAO0415H output modules:

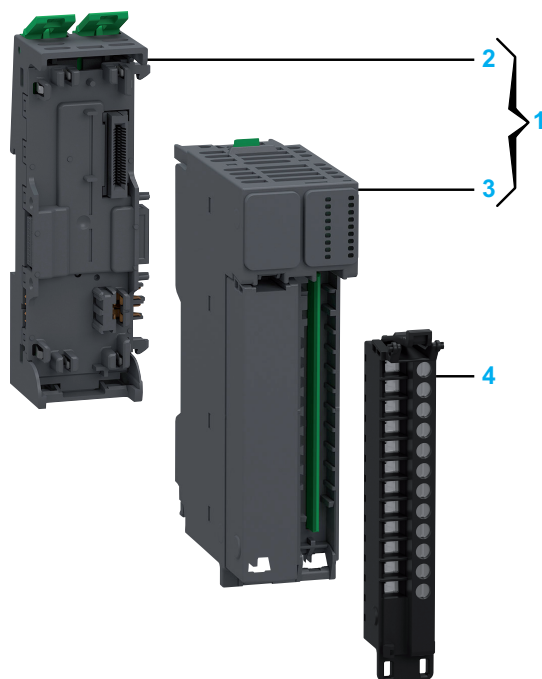

Number	Reference	Description
1	NTSDAO0415K	Base + Module (kit) NOTE: The module and its corresponding base can be purchased as a kit.
	NTSDAO0415HK	
2	NTSXBA0200H	Spare Base, 2 Slots, for Input/Output Common/Expert/Safety Module, Hardened
3	NTSDAO0415	Discrete Output Module, 4 Isolated Outputs, 2 A, 100...240 Vac, 1-/2-/3-wire, Hardened
	NTSDAO0415H	
4	NTSXTB12211H	Spring Terminal Block, 12 Points, 5 mm Pitch, With Cover, AC, use on Low Height Module, Hardened Screw Terminal Block, 12 Points, 5 mm Pitch, With Cover, AC, use on Low Height Module, Hardened Spring Terminal Block, 12 Points, 5 mm Pitch, Without Cover, AC, use on Low Height Module, Hardened Screw Terminal Block, 12 Points, 5 mm Pitch, Without Cover, AC, use on Low Height Module, Hardened NOTE: The terminal blocks are purchased separately.
	NTSXTB12011H	
	NTSXTB12210H	
	NTSXTB12010H	

NOTE: For more information on accessories and spare parts, refer to Modicon Edge I/O - System Planning and Installation Guide.

Physical Description

The following figure presents the elements of the module:

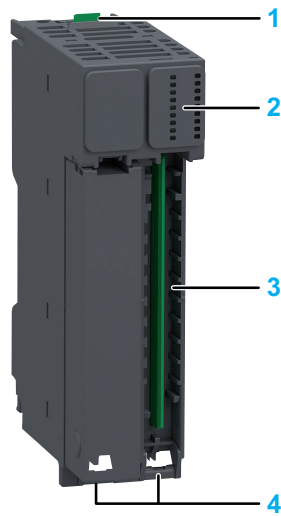

- 1: Release button for disengaging the module from the base
- 2: Status LEDs
- 3: Slot for the terminal block
- 4: Hinge for the terminal block installation

Status LEDs

The following figure presents the NTSDAO0415/NTSDAO0415H status LEDs:

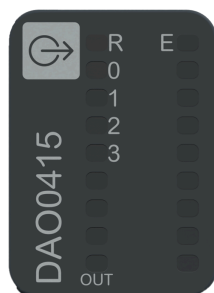

The following table describes the status of LEDs:

R (Green)	E (Red)	OUT0...3 (Green)	Description
Initialization and non-operational states			
OFF	OFF	OFF	Indicates that the module is not energized.
OFF	Fast Flash	-	Indicates that the module has detected a system error.
Regular Flash	OFF	-	Indicates that the firmware is being updated.
Regular Flash	ON	-	Indicates that a module mismatch is detected.
Single Flash	OFF	-	Indicates that the module is energized and not configured.
Operational state			
ON	OFF	-	Indicates that the module is energized, configured and operational.
ON	-	ON	Indicates that the corresponding output channel is activated.
ON	-	OFF	Indicates that the corresponding output channel is deactivated.
ON	Regular Flash	OFF	Indicates one of the following: <ul style="list-style-type: none"> • 24 Vdc field power error detection. • Sensor power supply error detection.

The following graphic depicts the system status of LEDs during module operation:

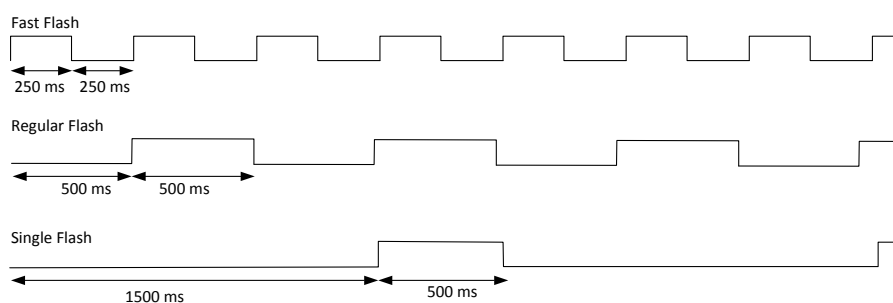

NTSDAO0415/NTSDAO0415H Characteristics

Overview

This section provides a general description of the characteristics of the module.

⚠ WARNING
UNINTENDED EQUIPMENT OPERATION
Do not exceed any of the rated values specified in the environmental and electrical characteristics tables.
Failure to follow these instructions can result in death, serious injury, or equipment damage.

For more information on environmental characteristics, refer to Modicon Edge I/O - System Planning and Installation Guide.

Dimensions

The following figure presents the external dimensions of the assembled module:

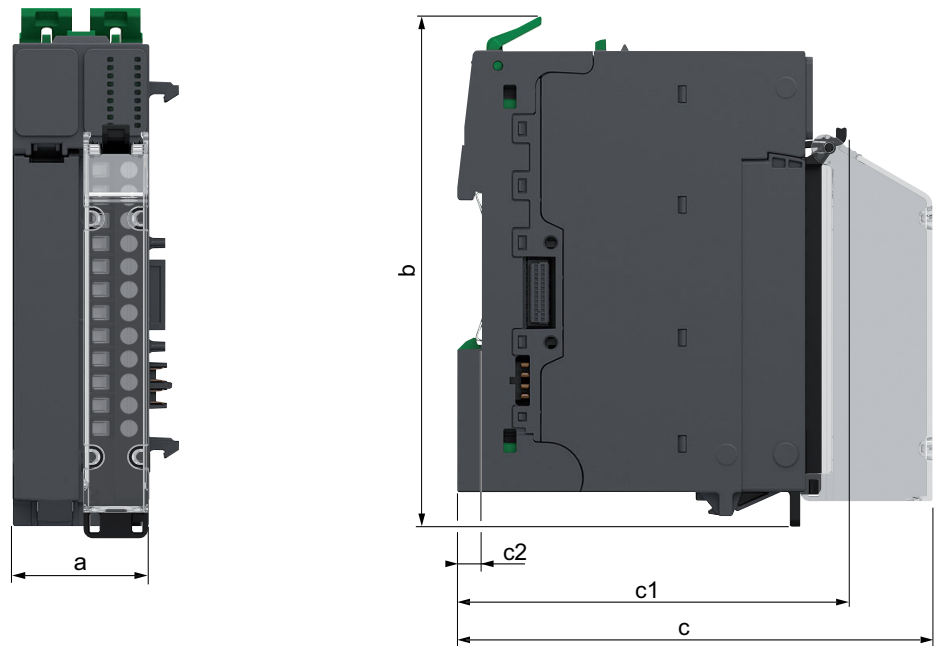

- a:** 30 mm (1.18 in)
- b:** 116.6 mm (4.57 in)
- c:** 107.5 mm (4.21 in)
- c1:** 88.2 mm (3.46 in)
- c2:** 5.6 mm (0.2 in)

Weight

- NTSDAO0415: 79 g (2.78 oz)
- NTSDAO0415K: 125 g (4.4 oz)
- NTSDAO0415H: 79 g (2.78 oz)
- NTSDAO0415HK: 125 g (4.4 oz)

General Characteristics

The following table describes the general characteristics of the NTSDAO0415/
NTSDAO0415H output modules:

Characteristics		Value
Output compatibility		1-/2-/3-wire
Field power supplied voltage requirements		From a 100...240 Vac external power supply
Power supplied voltage range		85...264 Vac (47...63 Hz)
Bus current consumption		37.2 mA
Field current consumption for actuators, per module		0 mA
Power dissipation		7.51 W
Maximum cable length	Shielded	200 m (656 ft)
	Unshielded	200 m (656 ft)
Isolation voltage	Between channels	2,500 Vac
	Between groups	-
	Between channel and bus	3,000 Vac
	Between channel and functional earth ground	3,000 Vac
Hot swap supported		Yes
Operating ambient temperature derating	Correct mounting position ⁽¹⁾	8 A per module: up to 40 °C (104 °F) 6 A per module: 40...50 °C (104...122 °F) 4 A per module: 50...60 °C (122...140 °F) 2 A per module: 60...70 °C (140...158 °F)
	Accepted mounting position ⁽¹⁾	8 A per module: up to 20 °C (68 °F) 7 A per module: 20...30 °C (68...86 °F) 6 A per module: 30...40 °C (86...104 °F) 4 A per module: 40... 50 °C (104... 122 °F) 2 A per module: 50...60 °C (122...140 °F)
⁽¹⁾ For information about mounting positions, refer to Modicon Edge I/O - System Planning and Installation Guide.		

Output Characteristics

The table below describes the output characteristics of the NTSDAO0415/NTSDAO0415H output modules:

Characteristics		Value
Output type		Triac
Output wiring mode		1-/2-/3-wire
Output current	Channel current	2 A
	Module current	8 A with a derating, page 246
Minimum switching current		5 mA
Operating frequency range		47...63 Hz
Response time on output	Logic state 1 to logic state 0	0.5 line cycles maximum
	Logic state 0 to logic state 1	0.5 line cycles maximum
Maximal OFF State Leakage /Channel		<ul style="list-style-type: none"> • 2.5 mA at 240 Vac • 2 mA at 120 Vac
Voltage drop at ON state		≤ 1.55 Vac
Paralleling of two outputs	For logic links or redundant control of load	Yes
Output protection	Over voltage	External Metal Oxide Varistor (MOV) or +RC snubber
	Short circuit	External 5 A fast blow fuse
Output diagnostic		Power supply monitoring (under voltage, power absent)

NTSDAO0415/NTSDAO0415H Wiring

Wiring Rules

For more information on the wiring, refer to Modicon Edge I/O - System Planning and Installation Guide.

Wiring Diagrams

Each group of inputs requires an external 100...240 Vac power supply with a 5 A / 250 V fuse.

To maintain the isolation between channels, use independent power supplies.

⚠ WARNING
UNINTENDED EQUIPMENT OPERATION
Use the sensor and actuator power supply only for supplying power to sensors or actuators connected to the module.
Failure to follow these instructions can result in death, serious injury, or equipment damage.

The following figure illustrates an example of 2-/3-wire connection outputs with an external power supply and isolation between channels:

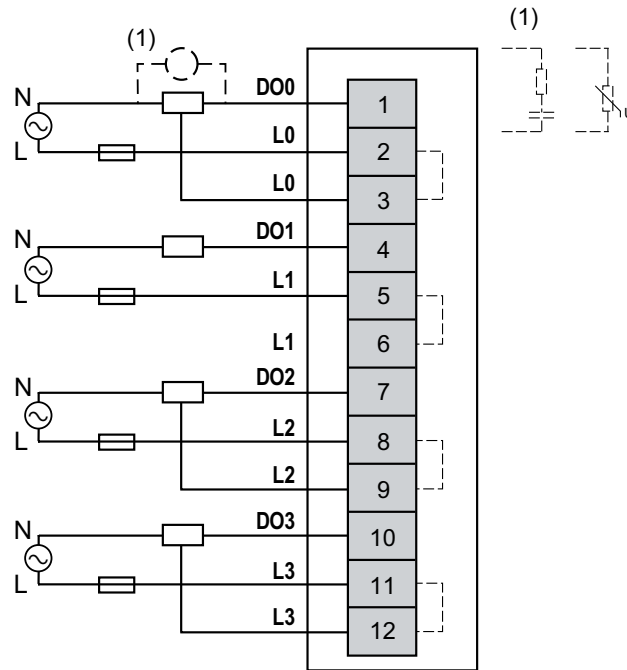

External Fuse: Type F, 5 A, 250 Vac is mandatory and must be chosen in compliance with IEC60269 standard.

The following figure illustrates an example of 1-/2-wire connection outputs with an external power supply and without isolation between channels:

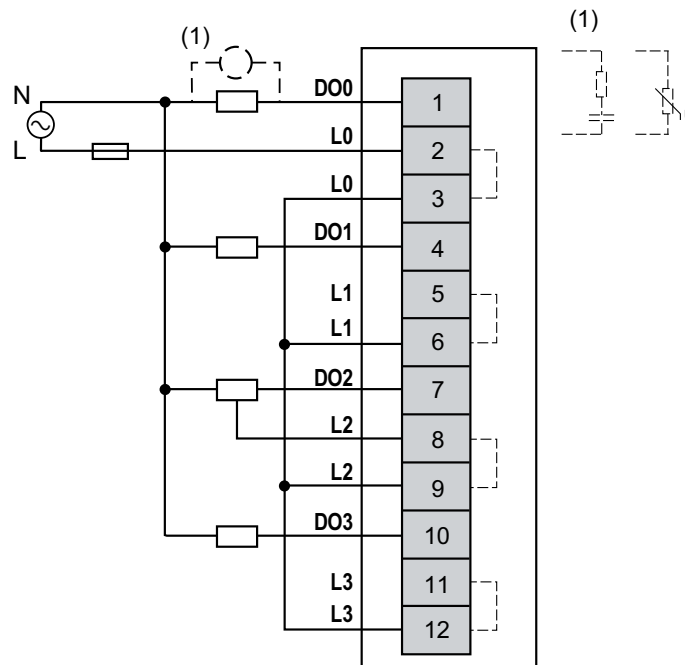

External Fuse: Type F, 20 A, 250 Vac is mandatory and must be chosen in compliance with IEC60269 standard.

NTSDAO0415/NTSDAO0415H Parameters

Parameters Description

Configurable Parameters

The following table presents the configurable parameters for the NTSDAO0415/NTSDAO0415H modules:

Displayed Name <i>Parameter Name</i>	Value	Data type	Description
Device Mode <i>DeviceMode</i>	0: Normal * 1: Optional 2: Virtual reserved	ENUM	Allows you to select the device mode: <ul style="list-style-type: none"> • Normal: The module is part of the software configuration and is physically connected in the cluster. • Optional: The module is part of the software configuration. A dummy module or the configured module must be physically installed in the cluster. Whether either module is present does not cause a configuration error to be detected. • Virtual reserved: The module is part of the software configuration. A dummy module must be physically installed in the cluster. If the virtual module is physically installed in the cluster, a configuration error is detected.
* Parameter default value			

The following table presents the configurable parameters for the channels of the NTSDAO0415/NTSDAO0415H modules:

Displayed Name <i>Parameter Name</i>	Value	Data type	Description
Channel Enabled <i>ChannelEnable</i> ⁽¹⁾	TRUE * FALSE	BOOL	Determines whether a channel is enabled or disabled.
Fallback Mode <i>OutputFallbackMode</i>	0: Fallback Value * 1: Maintain	ENUM	Allows you to select the behavior for the output in case of a communication interruption: <ul style="list-style-type: none"> • Fallback Value: Sets the output at the configured Predefined Fallback Value value. • Maintain: The output remains in its present state.
Predefined Fallback Value <i>OutputFallbackValue</i>	0 * 1	ENUM	Determines the state for the output in case of a communication interruption and Fallback Mode parameter is set to Predefined Fallback Value .
* Parameter default value			
⁽¹⁾ Online modification is allowed.			

Implicit Data

The following table presents the input implicit data for the module:

Parameter Name	Value	Data type Size in bytes R/W	Description
GCS	0...255	BYTE 1 R/-	Group Cyclic Status Bit 0: Data quality Bit 1: General module status Bit 2: I/O status Bit 3: Receive status Bit 4: Output status Bit 5: Advisory status Bit 6: N/A Bit 7: Data freshness NOTE: For more information, refer to Modicon Edge I/O - Diagnostic Data - User Guide.
(1) This parameter is not part of the implicit data if the optimized I/O profile is selected.			

The following table presents the output implicit data for the module:

Parameter Name	Value	Data type Size in bytes R/W	Description
QValue0_7	0...255	BYTE 1 R/W	Value of the output channels (Bit field). Bit 0...7 = Value of channel 0...7 NOTE: Unused bits are reserved.

Explicit Data

The following table presents the explicit data for the channels of the module:

Parameter Name	Value	Data type Size in bytes R/W	Description
QValue	TRUE = Channel is in logic state 1 FALSE = Channel is in logic state 0	BOOL R/W	Value of the output channel.

NTSDRC0215 Relay Output Module, 2 Isolated Outputs, NO/NC, 2 A, 5...125 Vdc, 24...240 Vac

What's in This Chapter

NTSDRC0215 Presentation 251
NTSDRC0215 Characteristics 255
NTSDRC0215 Wiring 258
NTSDRC0215 Parameters 261

NTSDRC0215 Presentation

Main Characteristics

The following table describes the main characteristics of the NTSDRC0215 output module:

Main Characteristics	Value
Product or component type	Discrete relay output module
Number of output channels	2
Groups of output channels	2 groups of 1 channel
Output logic type	form C Relay
Output voltage	24...250 Vac (47...63 Hz) 5...125 Vdc
Operating mode	Asynchronous

Purchasing Information

The following figure shows the elements of the Modicon Edge I/O NTS NTSDRC0215 output module:

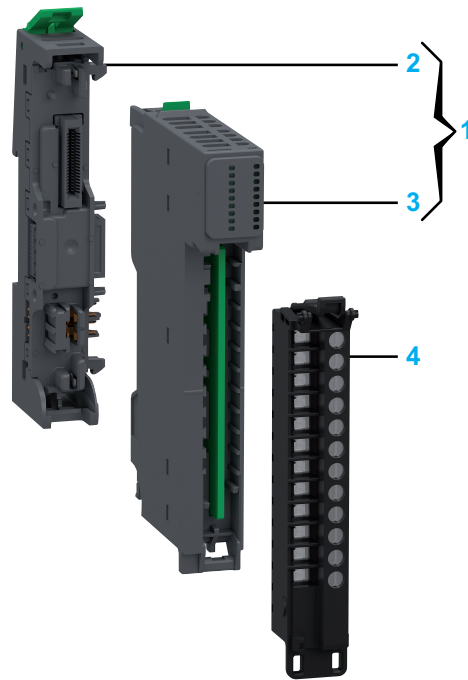

Number	Reference	Description
1	NTSDRC0215K	Base + Module (kit) NOTE: The module and its corresponding base can be purchased as a kit.
2	NTSXBA0100H	Spare Base, 1 Slot, for Input/Output Common or Expert Module, Hardened
3	NTSDRC0215	Relay Output Module, 2 Isolated Outputs, NO/NC, 2 A, 5...125 Vdc, 24...240 Vac
4	NTSXTB12211H NTSXTB12011H NTSXTB12210H NTSXTB12010H	Spring Terminal Block, 12 Points, 5 mm Pitch, With Cover, AC, use on Low Height Module, Hardened Screw Terminal Block, 12 Points, 5 mm Pitch, With Cover, AC, use on Low Height Module, Hardened Spring Terminal Block, 12 Points, 5 mm Pitch, Without Cover, AC, use on Low Height Module, Hardened Screw Terminal Block, 12 Points, 5 mm Pitch, Without Cover, AC, use on Low Height Module, Hardened NOTE: The terminal blocks are purchased separately.

NOTE: For more information on accessories and spare parts, refer to Modicon Edge I/O - System Planning and Installation Guide.

Physical Description

The following figure presents the elements of the module:

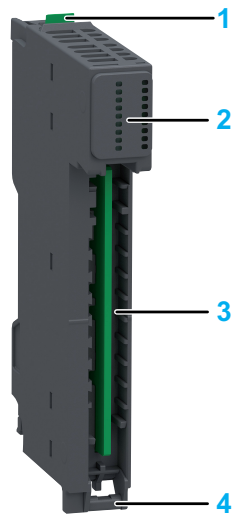

- 1: Release button for disengaging the module from the base
- 2: Status LEDs
- 3: Slot for the terminal block
- 4: Hinge for the terminal block installation

Status LEDs

The following figure presents the NTSDRC0215 status LEDs:

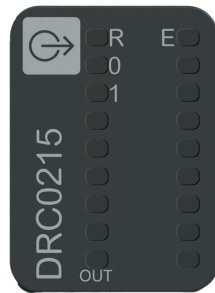

The following table describes the status of LEDs:

R (Green)	E (Red)	OUT0...1 (Green)	Description
Initialization and non-operational states			
OFF	OFF	OFF	Indicates that the module is not energized.
OFF	Fast Flash	-	Indicates that the module has detected a system error.
Regular Flash	OFF	-	Indicates that the firmware is being updated.
Regular Flash	ON	-	Indicates that a module mismatch is detected.
Single Flash	OFF	-	Indicates that the module is energized and not configured.
Operational state			
ON	OFF	-	Indicates that the module is energized, configured and operational.
ON	-	ON	Indicates that the corresponding output channel is activated.
ON	-	OFF	Indicates that the corresponding output channel is deactivated.
ON	Regular Flash	OFF	Indicates one of the following: <ul style="list-style-type: none"> • 24 Vdc field power error detection. • Sensor power supply error detection.

The following graphic depicts the system status of LEDs during module operation:

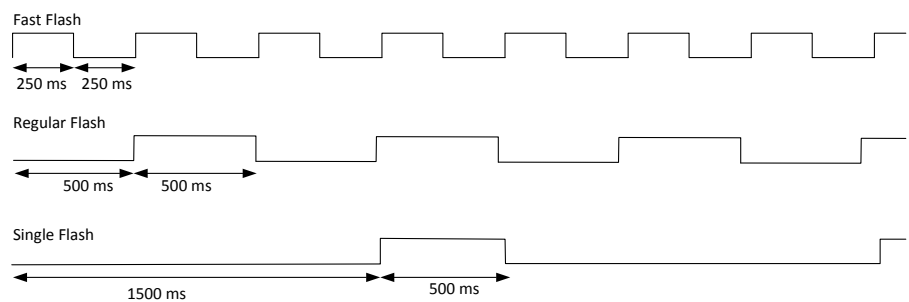

NTSDRC0215 Characteristics

Overview

This section provides a general description of the characteristics of the module.

⚠ WARNING

UNINTENDED EQUIPMENT OPERATION

Do not exceed any of the rated values specified in the environmental and electrical characteristics tables.

Failure to follow these instructions can result in death, serious injury, or equipment damage.

For more information on environmental characteristics, refer to Modicon Edge I/O - System Planning and Installation Guide.

Dimensions

The following figure presents the external dimensions of the assembled module:

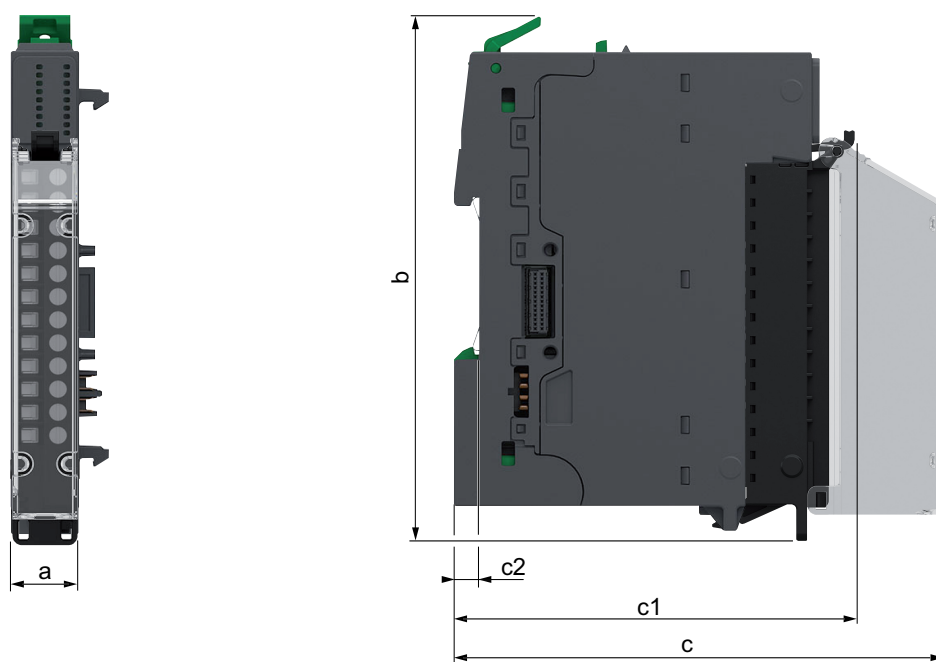

- a:** 15 mm (0.59 in)
- b:** 116.6 mm (4.57 in)
- c:** 107.5 mm (4.21 in)
- c1:** 88.2 mm (3.46 in)
- c2:** 5.6 mm (0.2 in)

Weight

- NTSDRC0215: 48 g (1.69 oz)
- NTSDRC0215K: 73 g (2.57 oz)

General Characteristics

The following table describes the general characteristics of the NTSDRC0215 output module:

Characteristics		Value
Output compatibility		2-wire
Field power supplied voltage requirements		From a 5...125 Vdc or a 24...250 Vac external power supply
Power supplied voltage range		20.4...28.8 Vdc
Bus current consumption		27.6 mA
Field current consumption for actuators, per module		21.4 mA
Power dissipation		1.53 W
Maximum cable length	Shielded	200 m (656 ft)
	Unshielded	200 m (656 ft)
Isolation voltage	Between channels	1,780 Vac
	Between groups	-
	Between channel and bus	3,000 Vac
	Between channel and functional earth ground	3,000 Vac
Hot swap supported		Yes
Operating ambient temperature derating		No derating

Output Characteristics

The table below describes the output characteristics of the NTSDRC0215 output module:

Characteristics		Value
Relay wiring type		C/O (Form C) contacts
Output wiring mode		2-Wire
Output current	Channel current	2 A
	Module current	-
Minimum switching current		5 Vdc / 10 mA
Maximum switching frequency		2 Hz for resistive load 0.5 Hz for inductive load
Response time on output	Logic state 1 to logic state 0	< 13 ms
	Logic state 0 to logic state 1	< 20 ms
Electrical endurance/switching cycles		With a resistive load: <ul style="list-style-type: none"> • 150 x 10³ at 2 A 250 Vac / 30 Vdc • 300 x 10³ at 1 A 250 Vac / 30 Vdc • 6 x 10³ at 0.2 A 125 Vdc With an inductive load: <ul style="list-style-type: none"> • 60 x 10³ at 2 A 250 Vac / 30 Vdc • 120 x 10³ at 1 A 250 Vac / 30 Vdc • 6 x 10³ at 0.2 A 125 Vdc
Paralleling of two outputs	For logic links or redundant control of load	Yes
Output protection	Over voltage	<ul style="list-style-type: none"> • AC: External Metal Oxide Varistor (MOV) or RC snubber • DC: External Metal Oxide Varisort (MOV) or inverse diode
	Short circuit	External fast blow fuse
Output diagnostic		Power supply monitoring (under voltage, power absent)

NTSDRC0215 Wiring

Wiring Rules

For more information on the wiring, refer to Modicon Edge I/O - System Planning and Installation Guide.

Wiring Diagrams

Each channel requires an external power supply (AC or DC) with the appropriate output protection.

To maintain the isolation between channels, use independent power supplies.

⚠ WARNING
UNINTENDED EQUIPMENT OPERATION
Use the sensor and actuator power supply only for supplying power to sensors or actuators connected to the module.
Failure to follow these instructions can result in death, serious injury, or equipment damage.

The following figure illustrates an example of 2-wire connection outputs with an external AC power supply and without isolation between channels:

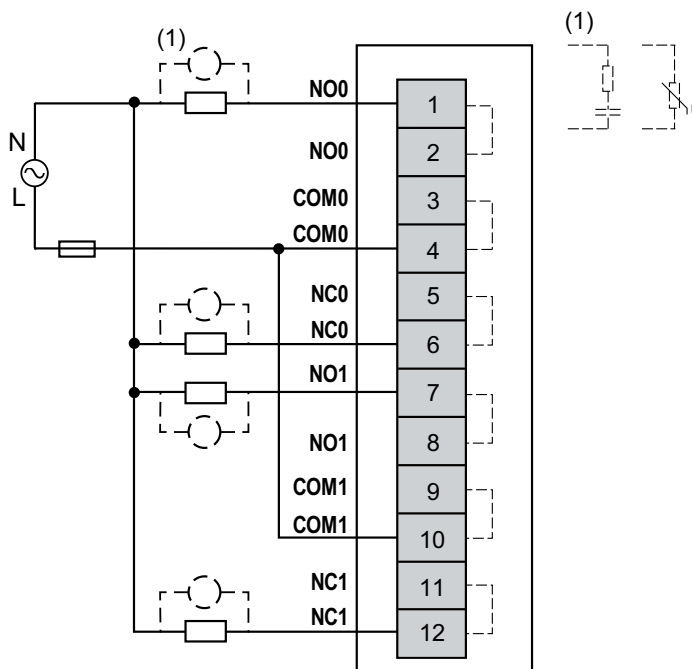

External Fuse: Type F, 2 A, 250 Vac is mandatory and must be chosen in compliance with IEC60269 standard.

The following figure illustrates an example of 2-wire connection outputs with an external DC power supply and without isolation between channels:

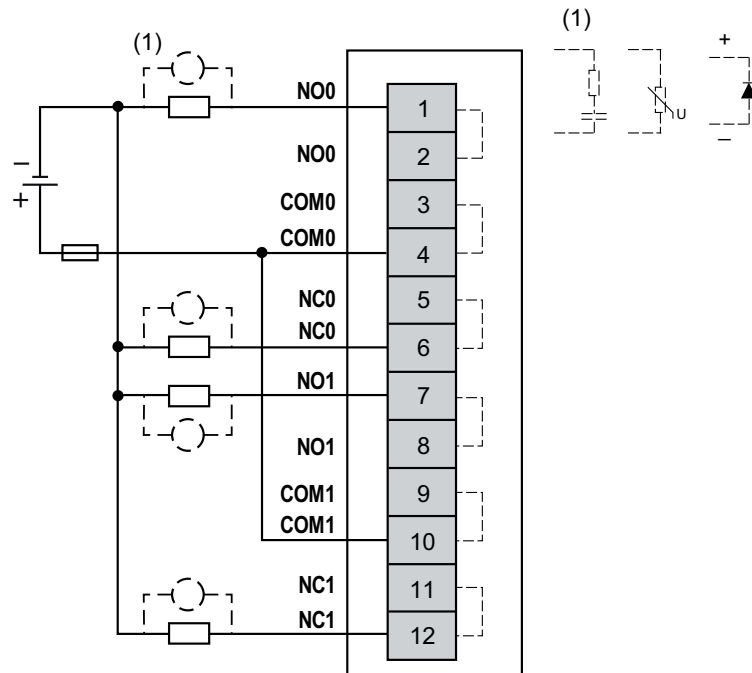

External Fuse: Type F, 2 A, 125 Vdc is mandatory and must be chosen in compliance with IEC60269 standard.

The following figure illustrates an example of 2-wire connection outputs with an external AC and DC power supply and isolation between channels:

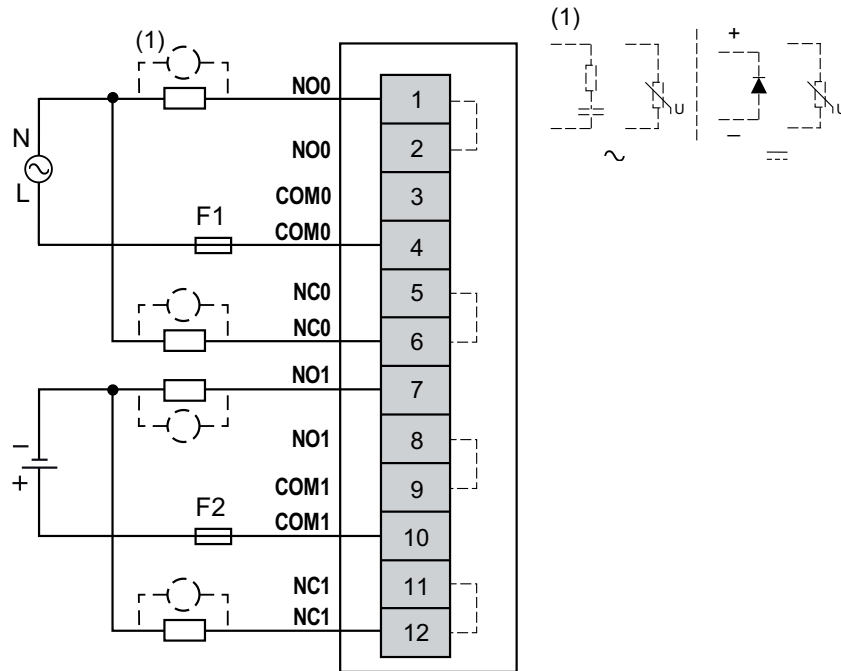

F1: External fuse type F, 2 A, 250 Vac is mandatory and must be chosen in compliance with IEC60269 standard.

F2: External fuse type F, 2 A, 125 Vdc is mandatory and must be chosen in compliance with IEC60269 standard.

⚠ WARNING

UNINTENDED EQUIPMENT OPERATION

Do not connect SELV power supply and hazardous voltage power supply to adjacent channels.

Failure to follow these instructions can result in death, serious injury, or equipment damage.

NTSDRC0215 Parameters

Parameters Description

Configurable Parameters

The following table presents the configurable parameters for the NTSDRC0215 module:

Displayed Name <i>Parameter Name</i>	Value	Data type	Description
Device Mode <i>DeviceMode</i>	0: Normal * 1: Optional 2: Virtual reserved	ENUM	Allows you to select the device mode: <ul style="list-style-type: none"> • Normal: The module is part of the software configuration and is physically connected in the cluster. • Optional: The module is part of the software configuration. A dummy module or the configured module must be physically installed in the cluster. Whether either module is present does not cause a configuration error to be detected. • Virtual reserved: The module is part of the software configuration. A dummy module must be physically installed in the cluster. If the virtual module is physically installed in the cluster, a configuration error is detected.
* Parameter default value			

The following table presents the configurable parameters for the channels of the NTSDRC0215 module:

Displayed Name <i>Parameter Name</i>	Value	Data type	Description
Channel Enabled <i>ChannelEnable</i> ⁽¹⁾	TRUE * FALSE	BOOL	Determines whether a channel is enabled or disabled.
Fallback Mode <i>OutputFallbackMode</i>	0: Fallback Value * 1: Maintain	ENUM	Allows you to select the behavior for the output in case of a communication interruption: <ul style="list-style-type: none"> • Fallback Value: Sets the output at the configured Predefined Fallback Value value. • Maintain: The output remains in its present state.
Predefined Fallback Value <i>OutputFallbackValue</i>	0 * 1	ENUM	Determines the state for the output in case of a communication interruption and Fallback Mode parameter is set to Predefined Fallback Value .
* Parameter default value			
⁽¹⁾ Online modification is allowed.			

Implicit Data

The following table presents the input implicit data for the module:

Parameter Name	Value	Data type Size in bytes R/W	Description
GCS	0...255	BYTE 1 R/-	Group Cyclic Status Bit 0: Data quality Bit 1: General module status Bit 2: I/O status Bit 3: Receive status Bit 4: Output status Bit 5: Advisory status Bit 6: N/A Bit 7: Data freshness NOTE: For more information, refer to Modicon Edge I/O - Diagnostic Data - User Guide.
ChannelHealth0_7 ⁽¹⁾	0...255	BYTE 1 R/-	Bit 0...7 = Status of channel 0...7 <ul style="list-style-type: none"> Bit = FALSE: Channel is invalid or not present. Bit = TRUE: Channel is valid or disabled.

⁽¹⁾ This parameter is not part of the implicit data if the optimized I/O profile is selected.

The following table presents the output implicit data for the module:

Parameter Name	Value	Data type Size in bytes R/W	Description
QValue0_7	0...255	BYTE 1 R/W	Value of the output channels (Bit field). Bit 0...7 = Value of channel 0...7 NOTE: Unused bits are reserved.

Explicit Data

The following table presents the explicit data for the channels of the module:

Parameter Name	Value	Data type Size in bytes R/W	Description
ChannelFault	0...255	BYTE R/-	Provides the following detected error on the channel: Bit 4: Internal power supply error detected NOTE: Unused bits are reserved.
QValue	TRUE = Channel is in logic state 1 FALSE = Channel is in logic state 0	BOOL R/W	Value of the output channel.

NTSDRC0415/NTSDRC0415H Relay Output Module, 4 Isolated Outputs, NO/NC, 5 A, 5...125 Vdc, 24...240 Vac, Standard/Hardened

What's in This Chapter

NTSDRC0415/NTSDRC0415H Presentation.....	263
NTSDRC0415/NTSDRC0415H Characteristics	267
NTSDRC0415/NTSDRC0415H Wiring Diagram	270
NTSDRC0415/NTSDRC0415H Parameters	272

NTSDRC0415/NTSDRC0415H Presentation

Main Characteristics

The following table describes the main characteristics of the NTSDRC0415/NTSDRC0415H output modules:

Main Characteristics	Value
Product or component type	Discrete relay output module
Number of output channels	4
Groups of output channels	4 groups of 1 channel
Output logic type	form C Relay
Output voltage	24...250 Vac (47...63 Hz) 5...125 Vdc
Operating mode	Asynchronous

Purchasing Information

The following figure shows the elements of the Modicon Edge I/O NTS NTSDRC0415/NTSDRC0415H output module:

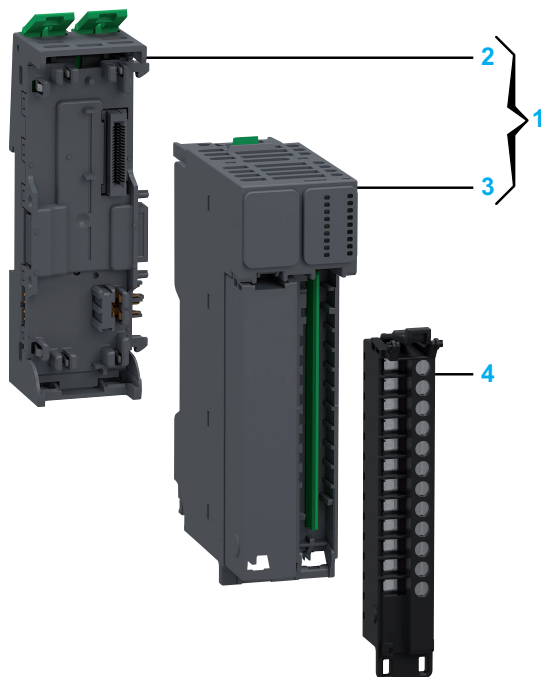

Number	Reference	Description
1	NTSDRC0415K	Base + Module (kit) NOTE: The module and its corresponding base can be purchased as a kit.
	NTSDRC0415HK	
2	NTSXBA0200H	Spare Base, 2 Slots, for Input/Output Common/Expert/Safety Module, Hardened
3	NTSDRC0415	Relay Output Module, 4 Isolated Outputs, NO/NC, 5 A, 5...125 Vdc, 24...240 Vac, Hardened
	NTSDRC0415H	
4	NTSXTB12211H	Spring Terminal Block, 12 Points, 5 mm Pitch, With Cover, AC, use on Low Height Module, Hardened Screw Terminal Block, 12 Points, 5 mm Pitch, With Cover, AC, use on Low Height Module, Hardened Spring Terminal Block, 12 Points, 5 mm Pitch, Without Cover, AC, use on Low Height Module, Hardened Screw Terminal Block, 12 Points, 5 mm Pitch, Without Cover, AC, use on Low Height Module, Hardened NOTE: The terminal blocks are purchased separately.
	NTSXTB12011H	
	NTSXTB12210H	
	NTSXTB12010H	

NOTE: For more information on accessories and spare parts, refer to Modicon Edge I/O - System Planning and Installation Guide.

Physical Description

The following figure presents the elements of the module:

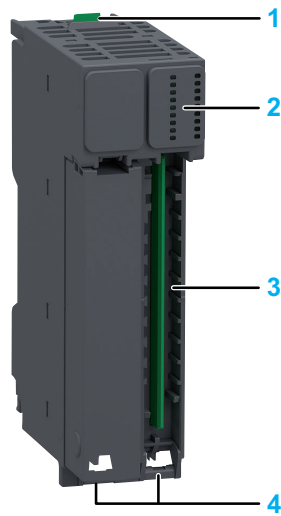

- 1: Release button for disengaging the module from the base
- 2: Status LEDs
- 3: Slot for the terminal block
- 4: Hinge for the terminal block installation

Status LEDs

The following figure presents the NTSDRC0415/NTSDRC0415H status LEDs:

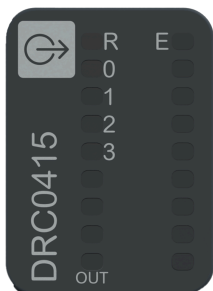

The following table describes the status of LEDs:

R (Green)	E (Red)	OUT0...3 (Green)	Description
Initialization and non-operational states			
OFF	OFF	OFF	Indicates that the module is not energized.
OFF	Fast Flash	-	Indicates that the module has detected a system error.
Regular Flash	OFF	-	Indicates that the firmware is being updated.
Regular Flash	ON	-	Indicates that a module mismatch is detected.
Single Flash	OFF	-	Indicates that the module is energized and not configured.
Operational state			
ON	OFF	-	Indicates that the module is energized, configured and operational.
ON	-	ON	Indicates that the corresponding output channel is activated.
ON	-	OFF	Indicates that the corresponding output channel is deactivated.
ON	Regular Flash	OFF	Indicates one of the following: <ul style="list-style-type: none"> 24 Vdc field power error detection. Sensor power supply error detection.

The following graphic depicts the system status of LEDs during module operation:

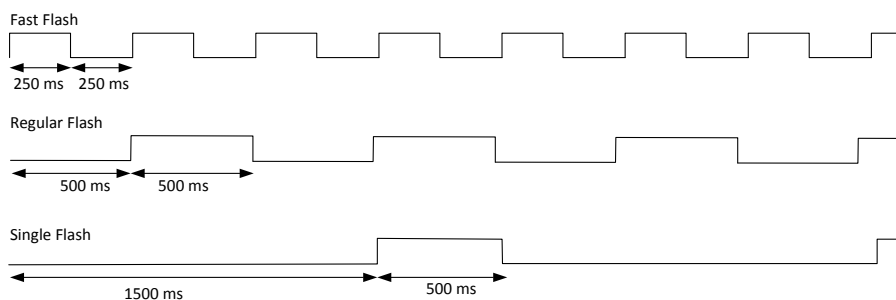

NTSDRC0415/NTSDRC0415H Characteristics

Overview

This section provides a general description of the characteristics of the module.

⚠ WARNING

UNINTENDED EQUIPMENT OPERATION

Do not exceed any of the rated values specified in the environmental and electrical characteristics tables.

Failure to follow these instructions can result in death, serious injury, or equipment damage.

For more information on environmental characteristics, refer to Modicon Edge I/O - System Planning and Installation Guide.

Dimensions

The following figure presents the external dimensions of the assembled module:

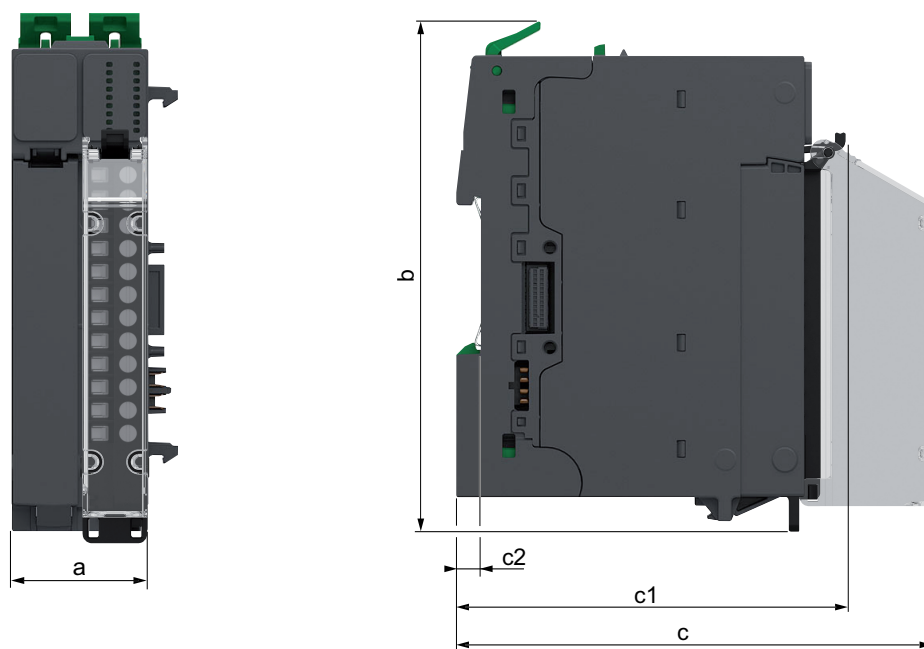

- a:** 30 mm (1.18 in)
- b:** 116.6 mm (4.57 in)
- c:** 107.5 mm (4.21 in)
- c1:** 88.2 mm (3.46 in)
- c2:** 5.6 mm (0.2 in)

Weight

- NTSDRC0415: 79 g (2.78 oz)
- NTSDRC0415K: 126 g (4.45 oz)
- NTSDRC0415H: 79 g (2.78 oz)
- NTSDRC0415HK: 127 g (4.48 oz)

General Characteristics

The following table describes the general characteristics of the NTSDRC0415/
NTSDRC0415H output modules:

Characteristics		Value
Output compatibility		2-wire
Field power supplied voltage requirements		From a 5...125 Vdc or a 24...250 Vac external power supply
Power supplied voltage range		20.4...28.8 Vdc
Bus current consumption		30 mA
Field current consumption for actuators, per module		41.4 mA
Power dissipation		5.33 W
Maximum cable length	Shielded	200 m (656 ft)
	Unshielded	200 m (656 ft)
Isolation voltage	Between channels	1,780 Vac
	Between groups	-
	Between channel and bus	3,000 Vac
	Between channel and functional earth ground	3,000 Vac
Hot swap supported		Yes
Operating ambient temperature derating	Correct mounting position ⁽¹⁾	20 A per module: up to 60 °C (140 °F) 15 A per module: 60...70 °C (140...158 °F) with Channel 0 disabled or 1 A per channel with all channels activated
	Accepted mounting position ⁽¹⁾	20 A per module: up to 50 °C (122 °F) 15 A per module: 50...60 °C (122...140 °F) with Channel 0 disabled or 1 A per channel with all channels activated
⁽¹⁾ For information about mounting positions, refer to Modicon Edge I/O - System Planning and Installation Guide.		

Output Characteristics

The table below describes the output characteristics of the NTSDRC0415/
NTSDRC0415H output modules:

Characteristics		Value
Relay wiring type		C/O (Form C) contacts
Output wiring mode		2-Wire
Output current	Channel current	5 A
	Module current	20 A with derating, page 268
Minimum switching current		5 Vdc / 10 mA
Maximum switching frequency		2 Hz for resistive load 0.5 Hz for inductive load
Response time on output	Logic state 1 to logic state 0	< 13 ms
	Logic state 0 to logic state 1	< 20 ms
Electrical endurance/switching cycles		With a resistive load: <ul style="list-style-type: none"> • 60 x 10³ at 5 A 250 Vac / 30 Vdc • 150 x 10³ at 2 A 250 Vac / 30 Vdc • 300 x 10³ at 1 A 250 Vac / 30 Vdc • 6 x 10³ at 0.2 A 125 Vdc With an inductive load: <ul style="list-style-type: none"> • 25 x 10³ at 5 A 250 Vac / 30 Vdc • 60 x 10³ at 2 A 250 Vac / 30 Vdc • 120 x 10³ at 1 A 250 Vac / 30 Vdc • 6 x 10³ at 0.2 A 125 Vdc
Paralleling of two outputs	For logic links or redundant control of load	Yes
Output protection	Over voltage	<ul style="list-style-type: none"> • AC: External Metal Oxide Varistor (MOV) or RC snubber • DC: External Metal Oxide Varistor (MOV) or inverse diode
	Short circuit	External fast blow fuse
Output diagnostic		Power supply monitoring (under voltage, power absent)

NTSDRC0415/NTSDRC0415H Wiring Diagram

Wiring Rules

For more information on the wiring, refer to Modicon Edge I/O - System Planning and Installation Guide.

Wiring Diagram

Each channel requires an external power supply (AC or DC) with the appropriate output protection.

To maintain the isolation between channels, use independent power supplies.

⚠ WARNING

UNINTENDED EQUIPMENT OPERATION

Use the sensor and actuator power supply only for supplying power to sensors or actuators connected to the module.

Failure to follow these instructions can result in death, serious injury, or equipment damage.

The following figure illustrates an example of 2-wire connection outputs with an external AC and DC power supply and isolation between channels:

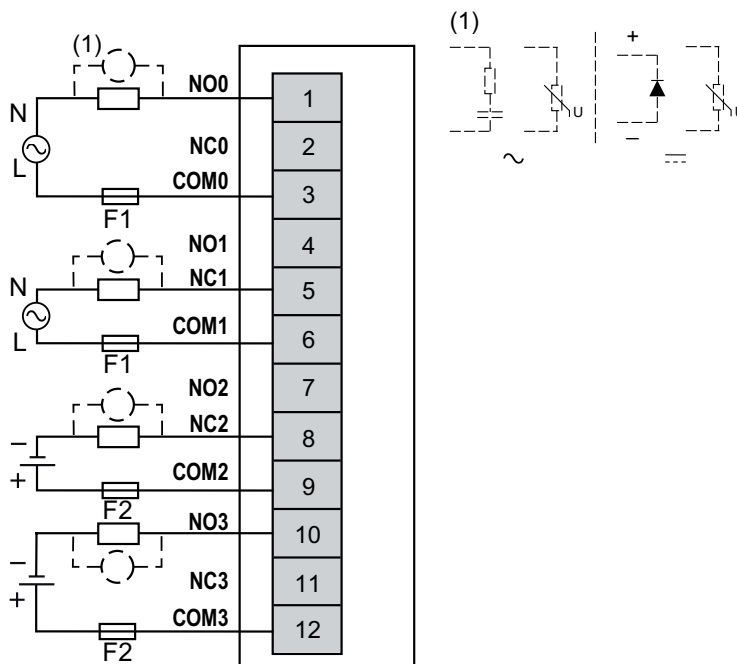

F1: External fuse type F, 2 A, 250 Vac is mandatory and must be chosen in compliance with IEC60269 standard.

F2: External fuse type F, 2 A, 125 Vdc is mandatory and must be chosen in compliance with IEC60269 standard.

⚠ WARNING

UNINTENDED EQUIPMENT OPERATION

Do not connect SELV power supply and hazardous voltage power supply to adjacent channels.

Failure to follow these instructions can result in death, serious injury, or equipment damage.

NTSDRC0415/NTSDRC0415H Parameters

Parameters Description

Configurable Parameters

The following table presents the configurable parameters for the NTSDRC0415/NTSDRC0415H modules:

Displayed Name <i>Parameter Name</i>	Value	Data type	Description
Device Mode <i>DeviceMode</i>	0: Normal* 1: Optional 2: Virtual reserved	ENUM	Allows you to select the device mode: <ul style="list-style-type: none"> • Normal: The module is part of the software configuration and is physically connected in the cluster. • Optional: The module is part of the software configuration. A dummy module or the configured module must be physically installed in the cluster. Whether either module is present does not cause a configuration error to be detected. • Virtual reserved: The module is part of the software configuration. A dummy module must be physically installed in the cluster. If the virtual module is physically installed in the cluster, a configuration error is detected.
* Parameter default value			

The following table presents the configurable parameters for the channels of the NTSDRC0415/NTSDRC0415H modules:

Displayed Name <i>Parameter Name</i>	Value	Data type	Description
Channel Enabled <i>ChannelEnable⁽¹⁾</i>	TRUE* FALSE	BOOL	Determines whether a channel is enabled or disabled.
Fallback Mode <i>OutputFallbackMode</i>	0: Fallback Value* 1: Maintain	ENUM	Allows you to select the behavior for the output in case of a communication interruption: <ul style="list-style-type: none"> • Fallback Value: Sets the output at the configured Predefined Fallback Value value. • Maintain: The output remains in its present state.
Predefined Fallback Value <i>OutputFallbackValue</i>	0* 1	ENUM	Determines the state for the output in case of a communication interruption and Fallback Mode parameter is set to Predefined Fallback Value .
⁽¹⁾ Online modification is allowed.			

Implicit Data

The following table presents the input implicit data for the module:

Parameter Name	Value	Data type Size in bytes R/W	Description
<i>GCS</i>	0...255	BYTE 1 R/-	Group Cyclic Status Bit 0: Data quality Bit 1: General module status Bit 2: I/O status Bit 3: Receive status Bit 4: Output status Bit 5: Advisory status Bit 6: N/A Bit 7: Data freshness NOTE: For more information, refer to Modicon Edge I/O - Diagnostic Data - User Guide.
<i>ChannelHealth0_7⁽¹⁾</i>	0...255	BYTE 1 R/-	Bit 0...7 = Status of channel 0...7 <ul style="list-style-type: none"> Bit = FALSE: Channel is invalid or not present. Bit = TRUE: Channel is valid or disabled.
⁽¹⁾ This parameter is not part of the implicit data if the optimized I/O profile is selected.			

The following table presents the output implicit data for the module:

Parameter Name	Value	Data type Size in bytes R/W	Description
<i>QValue0_7</i>	0...255	BYTE 1 R/W	Value of the output channels (Bit field). Bit 0...7 = Value of channel 0...7 NOTE: Unused bits are reserved.

Explicit Data

The following table presents the explicit data for the channels of the module:

Parameter Name	Value	Data type Size in bytes R/W	Description
<i>ChannelFault</i>	0...255	BYTE R/-	Provides the following detected error on the channel: Bit 4: Internal power supply error detected NOTE: Unused bits are reserved.
<i>QValue</i>	TRUE = Channel is in logic state 1 FALSE = Channel is in logic state 0	BOOL R/W	Value of the output channel.

NTSDRA0615 Relay Output Module, 6 Isolated Outputs, NO, 2 A, 5...125 Vdc, 24...240 Vac

What's in This Chapter

NTSDRA0615 Presentation	274
NTSDRA0615 Characteristics	278
NTSDRA0615 Wiring.....	281
NTSDRA0615 Parameters.....	283

NTSDRA0615 Presentation

Main Characteristics

The following table describes the main characteristics of the NTSDRA0615 output module:

Main Characteristics	Value
Product or component type	Discrete relay output module
Number of output channels	6
Groups of output channels	6 groups of 1 channel
Output logic type	form A Relay
Output voltage	24...250 Vac (47...63 Hz) 5...125 Vdc
Operating mode	Asynchronous

Purchasing Information

The following figure shows the elements of the Modicon Edge I/O NTS NTSDRA0615 output module:

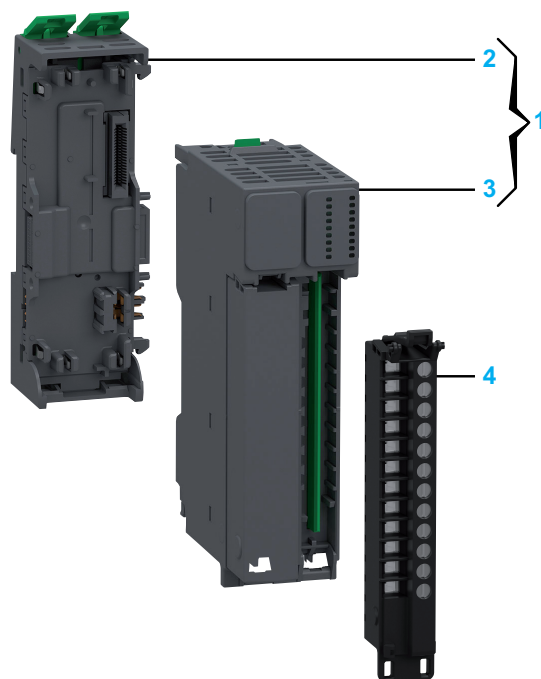

Number	Reference	Description
1	NTSDRA0615K	Base + Module (kit) NOTE: The module and its corresponding base can be purchased as a kit.
2	NTSXBA0200H	Spare Base, 2 Slots, for Input/Output Common/Expert/Safety Module, Hardened
3	NTSDRA0615	Relay Output Module, 6 Isolated Outputs, NO, 2 A, 5...125 Vdc, 24...240 Vac
4	NTSXTB12211H NTSXTB12011H NTSXTB12210H NTSXTB12010H	Spring Terminal Block, 12 Points, 5 mm Pitch, With Cover, AC, use on Low Height Module, Hardened Screw Terminal Block, 12 Points, 5 mm Pitch, With Cover, AC, use on Low Height Module, Hardened Spring Terminal Block, 12 Points, 5 mm Pitch, Without Cover, AC, use on Low Height Module, Hardened Screw Terminal Block, 12 Points, 5 mm Pitch, Without Cover, AC, use on Low Height Module, Hardened NOTE: The terminal blocks are purchased separately.

NOTE: For more information on accessories and spare parts, refer to Modicon Edge I/O - System Planning and Installation Guide.

Physical Description

The following figure presents the elements of the module:

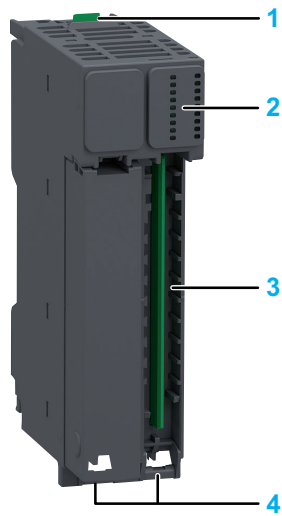

- 1: Release button for disengaging the module from the base
- 2: Status LEDs
- 3: Slot for the terminal block
- 4: Hinge for the terminal block installation

Status LEDs

The following figure presents the NTSDRA0615 status LEDs:



The following table describes the status of LEDs:

R (Green)	E (Red)	OUT0...5 (Green)	Description
Initialization and non-operational states			
OFF	OFF	OFF	Indicates that the module is not energized.
OFF	Fast Flash	-	Indicates that the module has detected a system error.
Regular Flash	OFF	-	Indicates that the firmware is being updated.
Regular Flash	ON	-	Indicates that a module mismatch is detected.
Single Flash	OFF	-	Indicates that the module is energized and not configured.
Operational state			
ON	OFF	-	Indicates that the module is energized, configured and operational.
ON	-	ON	Indicates that the corresponding output channel is activated.
ON	-	OFF	Indicates that the corresponding output channel is deactivated.
ON	Regular Flash	OFF	Indicates one of the following: <ul style="list-style-type: none"> • 24 Vdc field power error detection. • Sensor power supply error detection.
ON	Regular Flash	Regular Flash	Indicates one of the following: <ul style="list-style-type: none"> • Broken wire detection. • Short circuit detection.

The following graphic depicts the system status of LEDs during module operation:

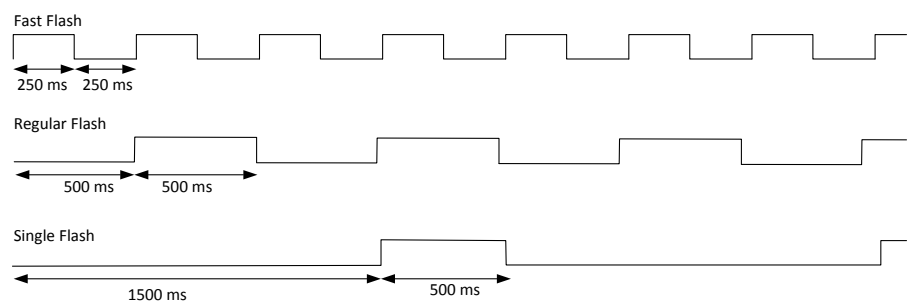

NTSDRA0615 Characteristics

Overview

This section provides a general description of the characteristics of the module.

⚠ WARNING

UNINTENDED EQUIPMENT OPERATION

Do not exceed any of the rated values specified in the environmental and electrical characteristics tables.

Failure to follow these instructions can result in death, serious injury, or equipment damage.

For more information on environmental characteristics, refer to Modicon Edge I/O - System Planning and Installation Guide.

Dimensions

The following figure presents the external dimensions of the assembled module:

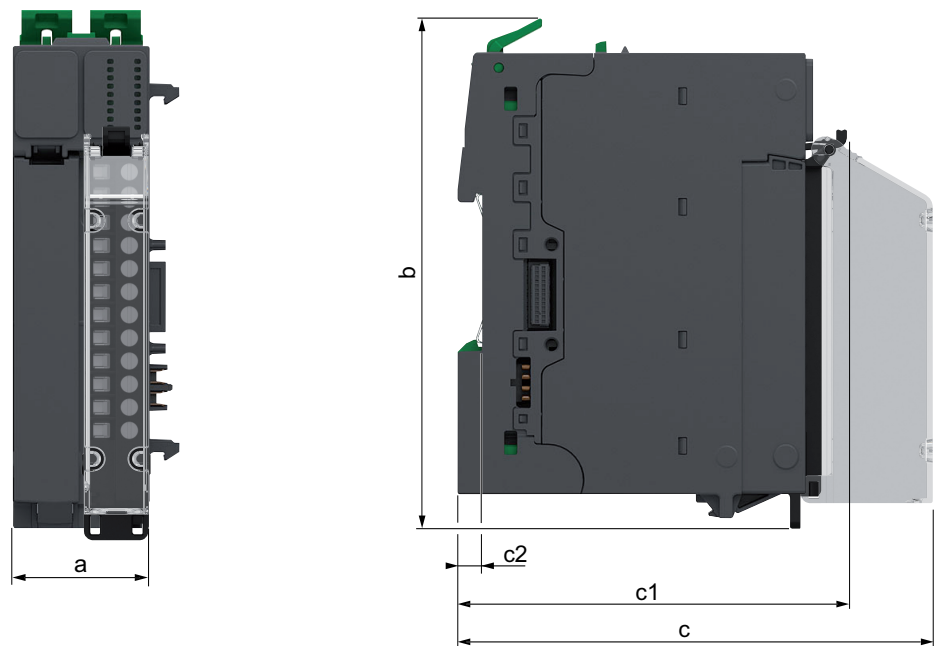

- a:** 30 mm (1.18 in)
- b:** 116.6 mm (4.57 in)
- c:** 107.5 mm (4.21 in)
- c1:** 88.2 mm (3.46 in)
- c2:** 5.6 mm (0.2 in)

Weight

- NTSDRA0615: 70 g (2.47 oz)
- NTSDRA0615K: 123 g (4.34 oz)

General Characteristics

The following table describes the general characteristics of the NTSDRA0615 output module:

Characteristics		Value
Output compatibility		2-wire
Field power supplied voltage requirements		From a 5...125 Vdc or a 24...250 Vac external power supply
Power supplied voltage range		20.4...28.8 Vdc
Bus current consumption		31.2 mA
Field current consumption for actuators, per module		41.4 mA
Power dissipation		2.35 W
Maximum cable length	Shielded	200 m (656 ft)
	Unshielded	200 m (656 ft)
Isolation voltage	Between channels	1,780 Vac
	Between groups	-
	Between channel and bus	3,000 Vac
	Between channel and functional earth ground	3,000 Vac
Hot swap supported		Yes
Operating ambient temperature derating		No derating

Output Characteristics

The table below describes the output characteristics of the NTSDRA0615 output module:

Characteristics		Value
Relay wiring type		NO (Form A) contacts
Output wiring mode		2-Wire
Output current	Channel current	2 A
	Module current	-
Minimum switching current		5 Vdc / 10 mA
Maximum switching frequency		2 Hz for resistive load 0.5 Hz for inductive load
Response time on output	Logic state 1 to logic state 0	< 13 ms
	Logic state 0 to logic state 1	< 10 ms
Electrical endurance/switching cycles		With a resistive load: <ul style="list-style-type: none"> • 150 x 10³ at 2 A 250 Vac / 30 Vdc • 300 x 10³ at 1 A 250 Vac / 30 Vdc With an inductive load: <ul style="list-style-type: none"> • 60 x 10³ at 2 A 250 Vac / 30 Vdc • 130 x 10³ at 1 A 250 Vac / 30 Vdc • 6 x 10³ at 0.2 A 125 Vdc (R150)
Paralleling of two outputs	For logic links or redundant control of load	Yes
Output protection	Over voltage	<ul style="list-style-type: none"> • AC: External Metal Oxide Varistor (MOV) or RC snubber • DC: External Metal Oxide Varistor (MOV) or inverse diode
	Short circuit	External fast blow fuse

NTSDRA0615 Wiring

Wiring Rules

For more information on the wiring, refer to Modicon Edge I/O - System Planning and Installation Guide.

Wiring Diagrams

Each channel requires an external power supply (AC or DC) with the appropriate output protection.

To maintain the isolation between channels, use independent power supplies.

⚠ WARNING

UNINTENDED EQUIPMENT OPERATION

Use the sensor and actuator power supply only for supplying power to sensors or actuators connected to the module.

Failure to follow these instructions can result in death, serious injury, or equipment damage.

⚠ WARNING

UNINTENDED EQUIPMENT OPERATION

Do not connect SELV power supply and hazardous voltage power supply to adjacent channels.

Failure to follow these instructions can result in death, serious injury, or equipment damage.

The following figure illustrates an example of 2-wire connection outputs with an external AC and DC power supply and isolation between channels:

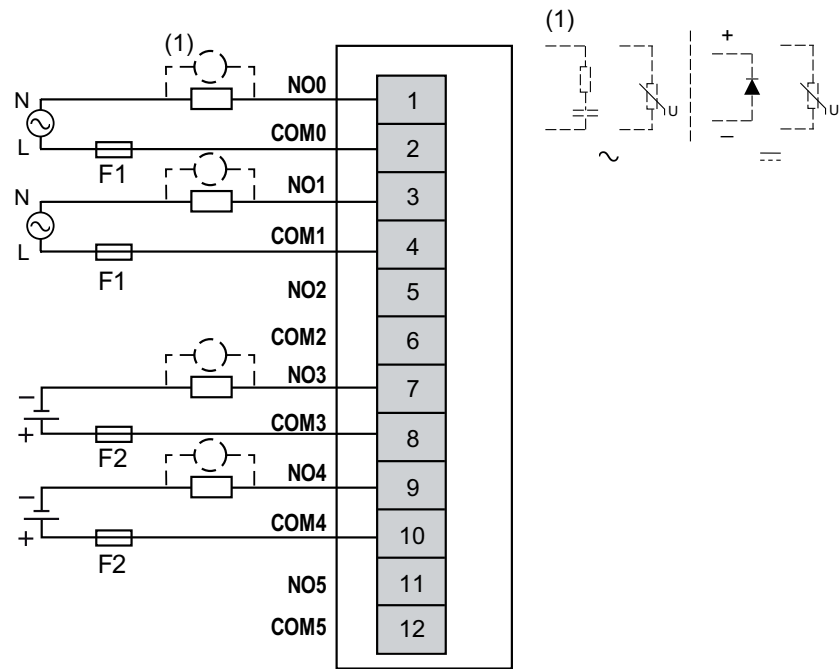

F1: External fuse type F, 2 A, 250 Vac is mandatory and must be chosen in compliance with IEC60269 standard.

F2: External fuse type F, 2 A, 125 Vdc is mandatory and must be chosen in compliance with IEC60269 standard.

The following figure illustrates an example of 3-wire connection outputs with an external AC and DC power supply and without isolation between channels:

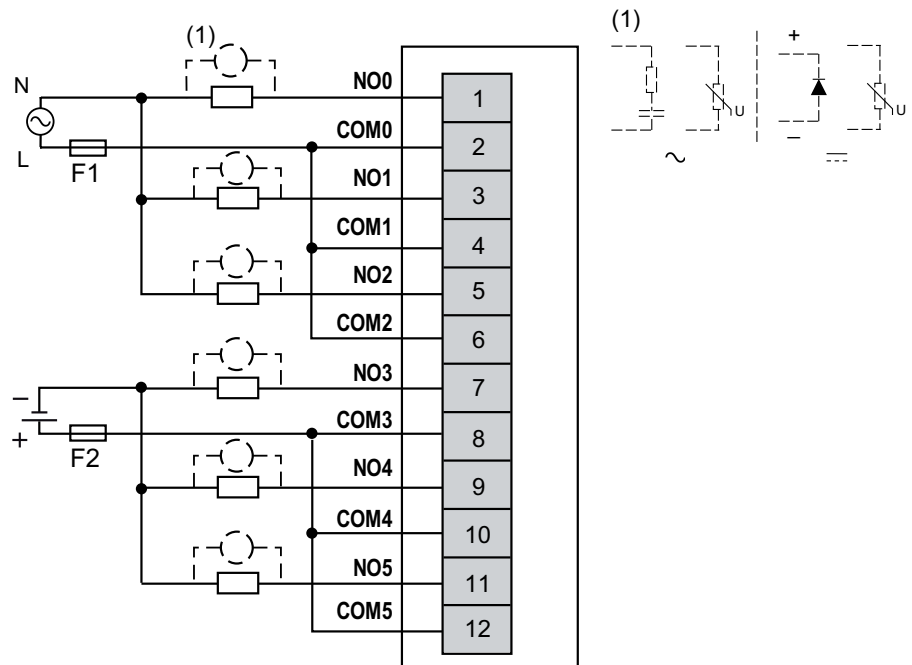

F1: External fuse type F, 2 A, 250 Vac is mandatory and must be chosen in compliance with IEC60269 standard.

F2: External fuse type F, 2 A, 125 Vdc is mandatory and must be chosen in compliance with IEC60269 standard.

NTSDRA0615 Parameters

Parameters Description

Configurable Parameters

The following table presents the configurable parameters for the NTSDRA0615 module:

Displayed Name <i>Parameter Name</i>	Value	Data type	Description
Device Mode <i>DeviceMode</i>	0: Normal * 1: Optional 2: Virtual reserved	ENUM	Allows you to select the device mode: <ul style="list-style-type: none"> • Normal: The module is part of the software configuration and is physically connected in the cluster. • Optional: The module is part of the software configuration. A dummy module or the configured module must be physically installed in the cluster. Whether either module is present does not cause a configuration error to be detected. • Virtual reserved: The module is part of the software configuration. A dummy module must be physically installed in the cluster. If the virtual module is physically installed in the cluster, a configuration error is detected.
* Parameter default value			

The following table presents the configurable parameters for the channels of the NTSDRA0615 module:

Displayed Name <i>Parameter Name</i>	Value	Data type	Description
Channel Enabled <i>ChannelEnable</i> ⁽¹⁾	TRUE * FALSE	BOOL	Determines whether a channel is enabled or disabled.
Fallback Mode <i>OutputFallbackMode</i>	0: Fallback Value * 1: Maintain	ENUM	Allows you to select the behavior for the output in case of a communication interruption: <ul style="list-style-type: none"> • Fallback Value: Sets the output at the configured Predefined Fallback Value value. • Maintain: The output remains in its present state.
Predefined Fallback Value <i>OutputFallbackValue</i>	0 * 1	ENUM	Determines the state for the output in case of a communication interruption and Fallback Mode parameter is set to Predefined Fallback Value .
* Parameter default value			
⁽¹⁾ Online modification is allowed.			

Implicit Data

The following table presents the input implicit data for the module:

Parameter Name	Value	Data type Size in bytes R/W	Description
GCS	0...255	BYTE 1 R/-	Group Cyclic Status Bit 0: Data quality Bit 1: General module status Bit 2: I/O status Bit 3: Receive status Bit 4: Output status Bit 5: Advisory status Bit 6: N/A Bit 7: Data freshness NOTE: For more information, refer to Modicon Edge I/O - Diagnostic Data - User Guide.
ChannelHealth0_7 ⁽¹⁾	0...255	BYTE 1 R/-	Bit 0...7 = Status of channel 0...7 <ul style="list-style-type: none"> Bit = FALSE: Channel is invalid or not present. Bit = TRUE: Channel is valid or disabled.

⁽¹⁾ This parameter is not part of the implicit data if the optimized I/O profile is selected.

The following table presents the output implicit data for the module:

Parameter Name	Value	Data type Size in bytes R/W	Description
QValue0_7	0...255	BYTE 1 R/W	Value of the output channels (Bit field). Bit 0...7 = Value of channel 0...7 NOTE: Unused bits are reserved.

Explicit Data

The following table presents the explicit data for the channels of the module:

Parameter Name	Value	Data type Size in bytes R/W	Description
ChannelFault	0...255	BYTE R/-	Provides the following detected error on the channel: Bit 4: Internal power supply error detected NOTE: Unused bits are reserved.
QValue	TRUE = Channel is in logic state 1 FALSE = Channel is in logic state 0	BOOL R/W	Value of the output channel.

Appendices

What's in This Part

Input Latch.....	286
Short Circuit Diagnostic and Recovery Methodology	289

Input Latch

Overview

The **Latch** parameter allows incoming pulses with a pulse width shorter than the network interface module scan time to be captured and recorded as depicted in the following diagram:

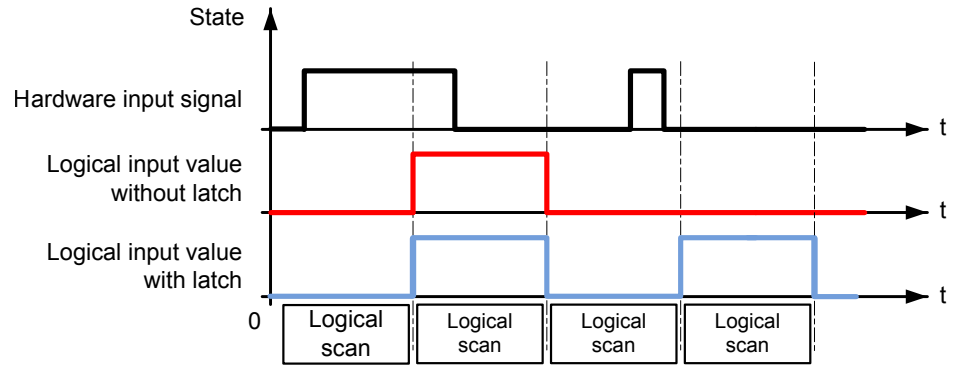

The shortest input pulse detected is determined by the bounce filter time.

A pulse can be captured either on a rising edge, a falling edge or on both edges. An acknowledge action is necessary before a new latch value can be captured.

Automatic Acknowledge

A rising edge on the **LatchAck** is done at each I/O bus cycle.

The following diagrams depicts the behavior of the input image in automatic acknowledge:

Rising Edge - Automatic Acknowledge:

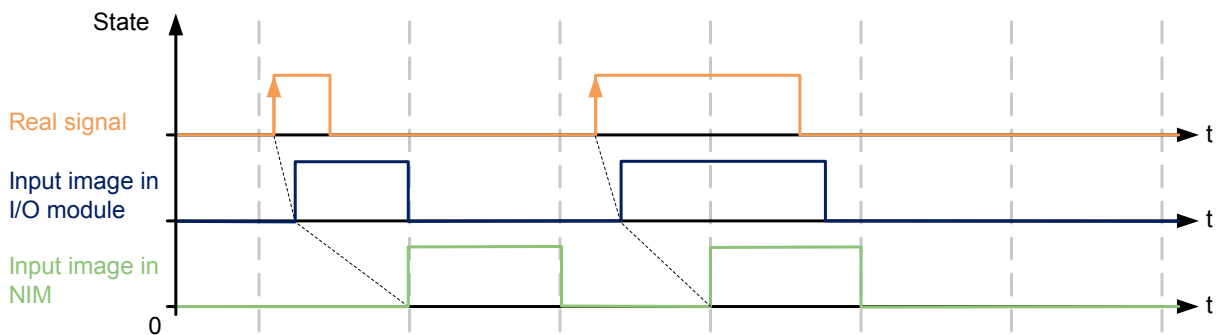

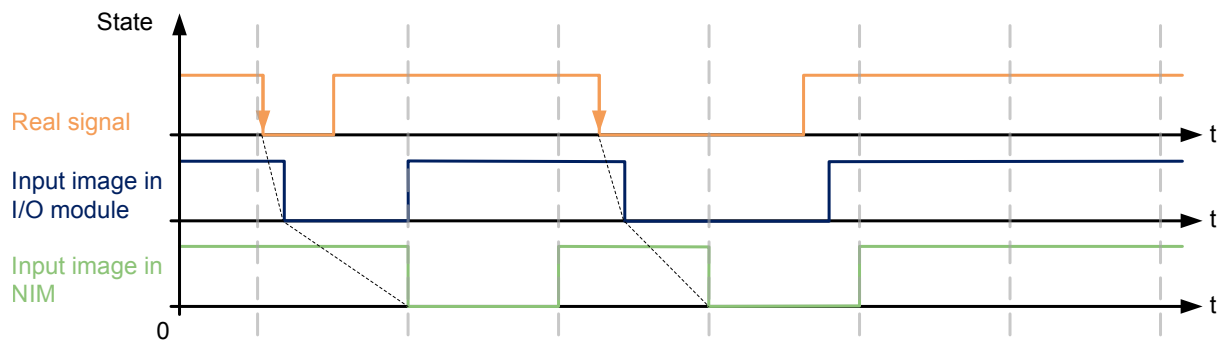
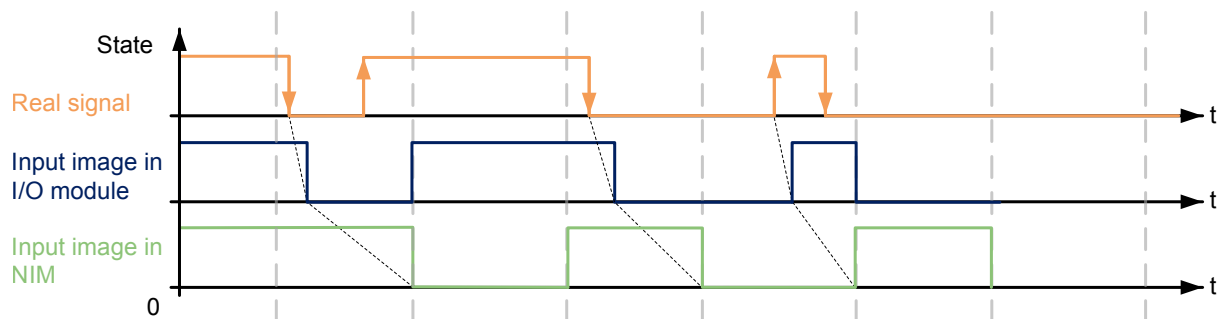
Falling Edge - Automatic Acknowledge:**Both Edges - Automatic Acknowledge:**

Manual Acknowledge

When an input value is latched, the input image in the I/O module is maintained at the latched value and a new value cannot be latched.

On a rising edge of the **LatchAck** bit, the input image in the I/O module is no longer maintained and a new value can be latched.

The following diagrams depict the behavior of the input image in manual acknowledge:

Rising Edge - Manual Acknowledge:

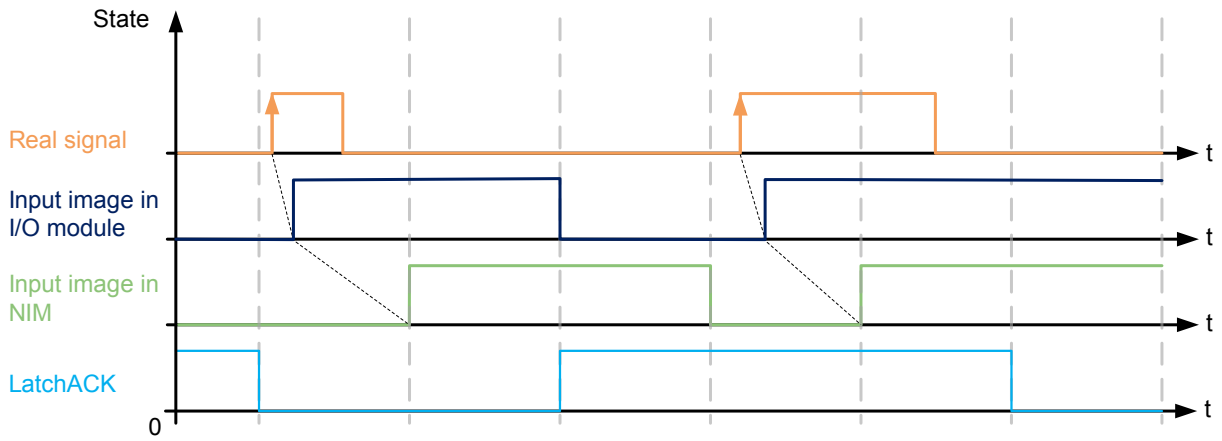

Falling Edge - Manual Acknowledge:

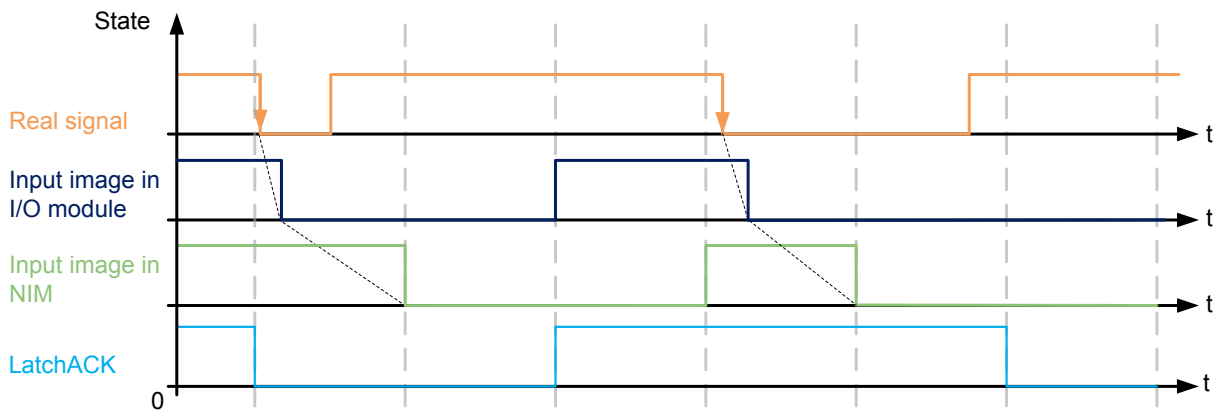

Both Edges - Manual Acknowledge:

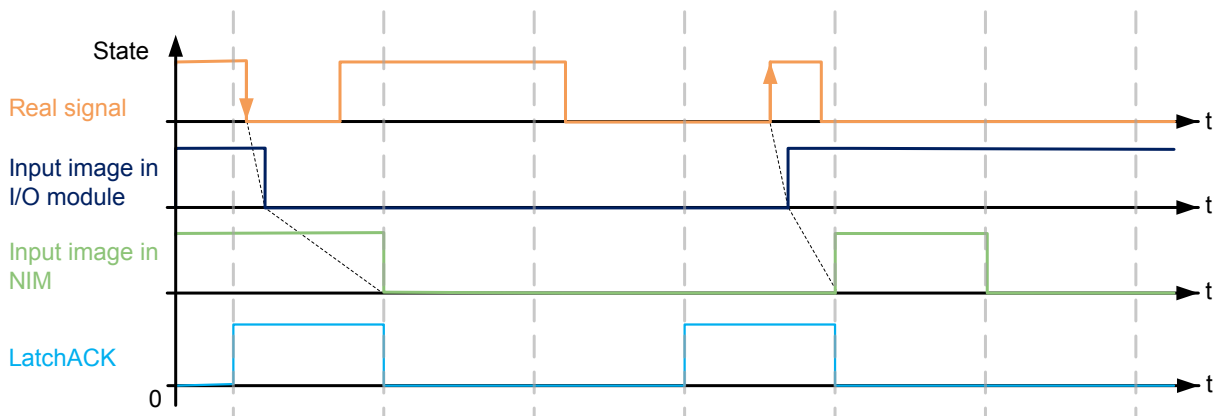

Short Circuit Diagnostic and Recovery Methodology

What's in This Chapter

Auto Recovery Mode	289
Latched Off Mode	292

Short circuit diagnostics are conducted on output pairs for the NTSSDO0602, NTSSDO0802X, NTSSDO1602, NTSSDO1602X / NTSSDO1602XH and NTSSDO1602XA / NTSSDO1602XAHK modules. For example, on a given NTSSDO1602•• module, DO0 and DO1 are considered a diagnostic pair, DO2 and DO3 are considered a diagnostic pair and so on. The following section presents the behavior associated with that pairing when a short circuit is detected on one, or both, output pairs.

Short circuit diagnostics detect an over-current, and, once recognized, de-energize both outputs of the pair that were energized at the time of detection. Any further intervention on the part of the controller or by you depends on whether **Auto Recovery** or **Latched Off** mode is configured for the diagnostic pair.

In short, the keys to understanding the treatment methodology is knowing the value of the outputs in the pair at the time of the short circuit detection and knowing the **Rearming Output Mode** selected for the module.

Auto Recovery Mode

Depending on the use case, the **Auto Recovery** mode attempts to re-arm the output or outputs every two seconds by energizing the output or outputs for a duration of $10\text{ ms} + 2 \times \text{IO Bus Cycle Time}$ in an infinite cycle. At any point when a short circuit is no longer detected on either of the outputs, the **Auto Recovery** terminates and the outputs in the pair take on their proper state as determined by the logical value of the outputs (as defined in the bytes *Qvalue0_7* or *Qvalue8_15*, depending on the pair).

Both Outputs Energized

If both outputs in the pair were energized prior to short circuit detection, and whether there was a short circuit on one or the other output of the pair, or both outputs of the pair, both outputs are treated with the **Auto Recovery** algorithm.

If only one of the two outputs had, in reality, a short circuit while the other output in the pair did not exhibit a short circuit, both outputs will be subjected to the **Auto Recovery** algorithm regardless, as depicted in the following diagram with the output pair DO0 and DO1 as examples:

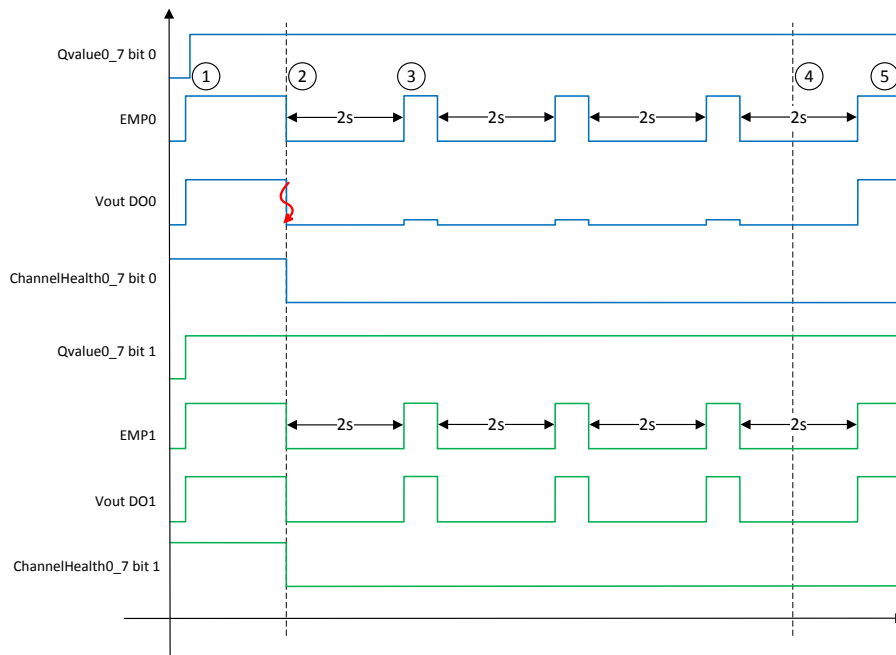

Stage	Description
1	When <i>Qvalue0_7</i> bit 0 and bit 1 are TRUE, the DO0 and DO1 outputs are energized (EMP0 and EMP1 are set to TRUE).
2	When a short circuit is detected on output DO0: <ul style="list-style-type: none"> <i>ChannelHealth0_7</i> bit 0 and bit 1 are set to FALSE. The DO0 and DO1 outputs are de-energized (EMP0 and EMP1 are set to FALSE). Auto recovery algorithm starts for the DO0 and DO1 outputs.
3	Every two seconds, the auto-recovery algorithm energizes the outputs DO0 and DO1 (<i>Vout</i> > 0) for a duration of 10 ms + 2 x IO Bus Cycle Time . At the end of the cycle, the short circuit is still detected, DO0 and DO1 output are de-energized.
4	The cause of the short circuit is cleared.
5	The auto recovery algorithm energizes the outputs DO0 and DO1 and no short circuit is detected. At the end of the cycle, <i>ChannelHealth0_7</i> bit 0 and bit 1 are set to TRUE. At this point, normal operation resumes.

⚠ WARNING

UNINTENDED EQUIPMENT OPERATION

Inhibit the automatic rearming of outputs if this feature presents undesirable operation of your machine or process.

Failure to follow these instructions can result in death, serious injury, or equipment damage.

One Output Energized

If only one of the outputs in the pair is energized at short circuit detection, then evidently the output that is energized caused the diagnostic detection and is subject to the **Auto Recovery** algorithm.

The other output in the pair that was de-energized at the short circuit detection is considered healthy and is not subject to the **Auto Recovery** algorithm.

Assuming that DO0 has the short circuit for example, *ChannelHealth0_7* bit 0 would be FALSE and *ChannelHealth0_7* bit 1 would be TRUE as long as the unaffected output remained de-energized for the duration of the **Auto Recovery** algorithm.

If, however, the unaffected output of the pair is energized and remains energized during one of the retries, the unaffected output joins the short circuited output in the **Auto Recovery** algorithm, as depicted in the following diagram:

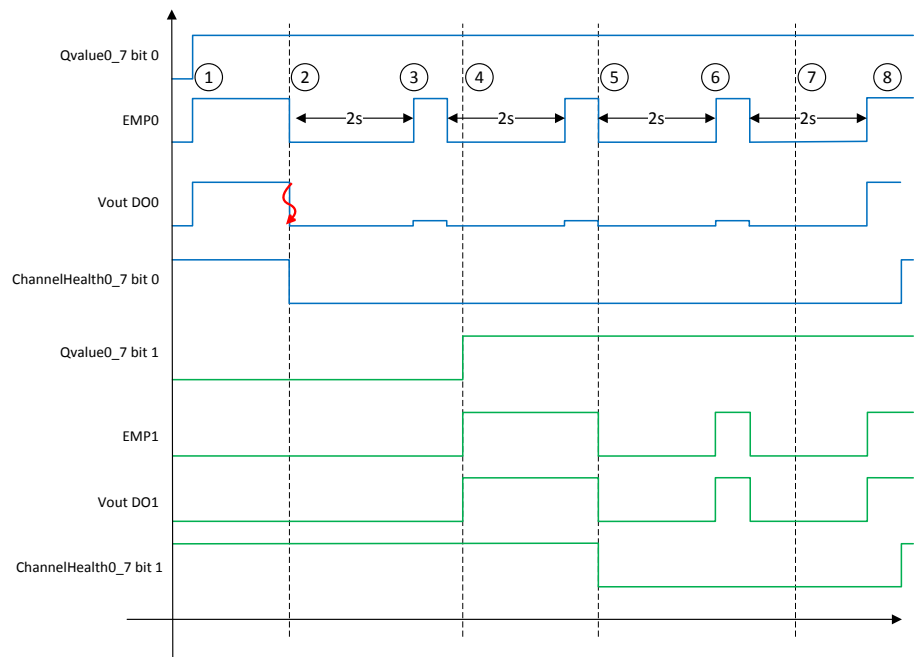

Stage	Description
1	When <i>Qvalue0_7</i> bit 0 is TRUE, the DO0 outputs is energized (EMP0 is set to TRUE).
2	When a short circuit is detected on output DO0: <ul style="list-style-type: none"> <i>ChannelHealth0_7</i> bit 0 is set to FALSE. The DO0 output is de-energized (EMP0 is set to FALSE). Auto recovery algorithm starts for the DO0 output. NOTE: Since <i>Qvalue0_7</i> bit 1 is FALSE, DO1 is de-energized and <i>ChannelHealth0_7</i> bit 1 keeps its present state.
3	Every two seconds, the auto-recovery algorithm energizes the outputs DO0 ($V_{out} > 0$) for a duration of $10\text{ ms} + 2 \times \text{IO Bus Cycle Time}$. The short circuit is still detected on DO0 and is de-energized at the end of the cycle.
4	In this example, <i>Qvalue0_7</i> bit 1 becomes TRUE, the DO1 output is energized (EMP1 is set to TRUE).
5	When the auto recovery algorithm energizes the output DO0 ($V_{out} > 0$) and the short circuit is still detected on output DO0, at the end of the cycle and because DO1 is energized while a retry is attempted: <ul style="list-style-type: none"> <i>ChannelHealth0_7</i> bit 1 is set to FALSE. The DO0 and DO1 output are de-energized (EMP0 and EMP1 is set to FALSE). Auto recovery algorithm starts for DO0 and DO1 outputs.

6	<p>Every two seconds, the auto-recovery algorithm energizes the outputs DO0 and DO1 ($V_{out} > 0$) for a duration of $10\text{ ms} + 2 \times \text{IO Bus Cycle Time}$.</p> <p>At the end of the cycle, the short circuit is still detected, DO0 and DO1 output are de-energized.</p>
7	The cause of the short circuit is cleared.
8	<p>The auto recovery algorithm energizes the outputs DO0 and DO1 and no short circuit is detected.</p> <p>At the end of the cycle, <i>ChannelHealth0_7</i> bit 0 and bit 1 are set to TRUE. At this point, normal operation resumes.</p>

⚠ WARNING

UNINTENDED EQUIPMENT OPERATION

Inhibit the automatic rearming of outputs if this feature presents undesirable operation of your machine or process.

Failure to follow these instructions can result in death, serious injury, or equipment damage.

Latched Off Mode

In **Latched Off Mode**, the attempt to re-arm the output or outputs by energizing the output or outputs for $10\text{ ms} + 2 \times \text{IO Bus Cycle Time}$ is on command. The reaction to the command to re-arm depends on the use case. When the short circuit is cleared, and you command the retry, the output or outputs in the pair take on the proper state as determined by the logical value of the outputs (as defined in the bytes *Qvalue0_7* or *Qvalue8_15*, depending on the pair).

Both Outputs Energized

If both outputs in the pair are energized at the time of the detection of a short circuit, and whether there is a short circuit on one or the other outputs of the pair, or both outputs in the pair, both outputs are de-energized and both health bits of the pair are set to FALSE.

Upon a commanded retry, if one or the other, or both, outputs continue to present a short circuit, the outputs of the pair resume their de-energized state as well as the pair of health bits retain their FALSE state.

If instead the short circuit is cleared, and therefore the short circuit error is no longer detected, the outputs of the pair take on the proper state as defined in the bytes *Qvalue0_7* or *Qvalue8_15*, depending on the pair.

This behavior is depicted in the following diagram:

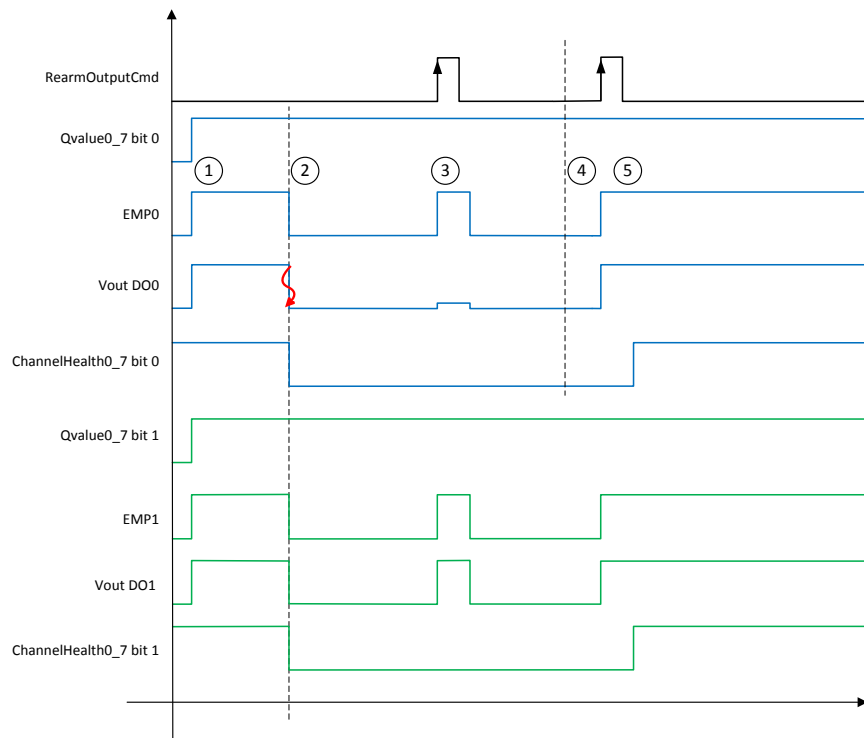

Stage	Description
1	When <i>Qvalue0_7</i> bit 0 and bit 1 are TRUE, the DO0 and DO1 outputs are energized (EMP0 and EMP1 are set to TRUE).
2	When a short circuit is detected on output DO0: <ul style="list-style-type: none"> <i>ChannelHealth0_7</i> bit 0 and bit 1 are set to FALSE. The DO0 and DO1 outputs are de-energized (EMP0 and EMP1 are set to FALSE).
3	A rising edge on <i>RearmOutputCmd</i> starts the retry attempt. The DO0 and DO1 outputs are energized (<i>Vout</i> > 0) for a duration of 10 ms + 2 x IO Bus Cycle Time . At the end of the retry attempt duration, the short circuit is still detected, DO0 and DO1 output are de-energized.
4	The cause of the short circuit is cleared.
5	A rising edge on <i>RearmOutputCmd</i> starts the retry attempt. No short circuit is detected, <i>ChannelHealth0_7</i> bit 0 and bit 1 are set to TRUE at the end of the retry attempt. At this point, normal operation resumes.

However, if in the interim between when a short circuit is detected and the command to retry, you set by whatever logical means the *Qvalue0_7* bit of the unaffected output of the pair to FALSE, upon the command to retry, the de-energized output has its health bit set to TRUE, and thereafter assume the proper state as defined in the bytes *Qvalue0_7* or *Qvalue8_15*, depending on the pair (assuming that the short circuit was not detected on the de-energized output).

This behavior is depicted in the following diagram:

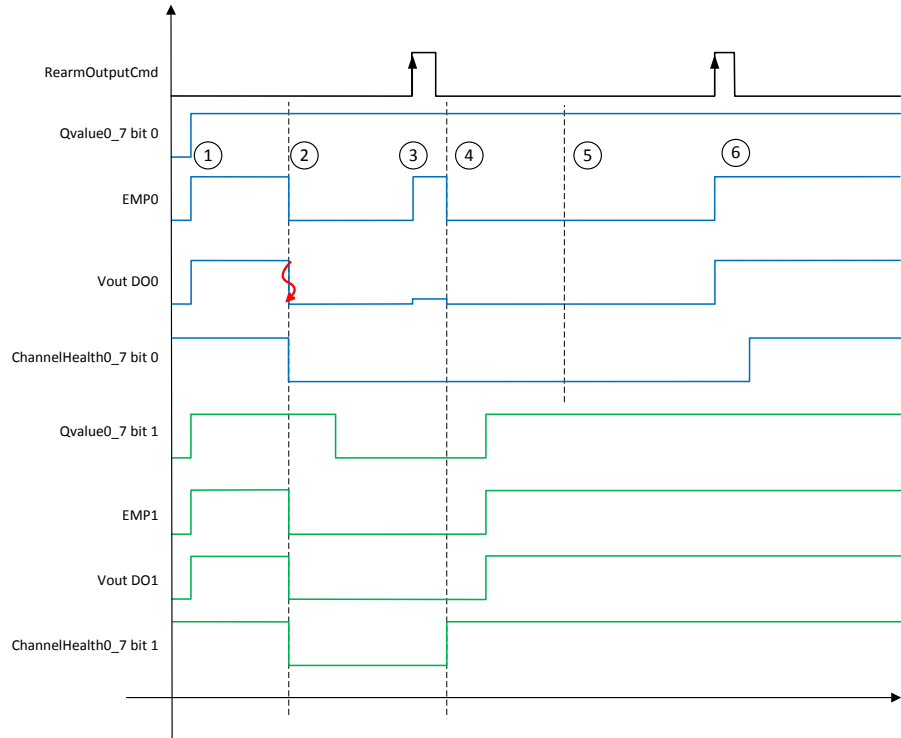

Stage	Description
1	When <i>Qvalue0_7</i> bit 0 and bit 1 are TRUE, the DO0 and DO1 outputs are energized (EMP0 and EMP1 are set to TRUE).
2	When a short circuit is detected on output DO0: <ul style="list-style-type: none"> <i>ChannelHealth0_7</i> bit 0 and bit 1 are set to FALSE. The DO0 and DO1 outputs are de-energized (EMP0 and EMP1 are set to FALSE).
3	A rising edge on <i>RearmOutputCmd</i> starts the retry attempt. <i>Qvalue0_7</i> bit 1 is FALSE, only DO0 outputs is energized ($V_{out} > 0$) for a duration of $10\text{ ms} + 2 \times \text{IO Bus Cycle Time}$, at the end of the retry attempt duration: <ul style="list-style-type: none"> The short circuit is still detected, DO0 output is de-energized. <i>ChannelHealth0_7</i> bit 1 is set to TRUE.
4	In this example, <i>Qvalue0_7</i> bit 1 becomes TRUE, the DO1 output is energized (EMP1 is set to TRUE).
5	The cause of the short circuit is cleared.
6	A rising edge on <i>RearmOutputCmd</i> starts the retry attempt. No short circuit is detected, <i>ChannelHealth0_7</i> bit 0 and bit 1 are set to TRUE at the end of the retry attempt. At this point, normal operation resumes.

One Output Energized

If only one of the outputs in the pair is energized at the detection of the short circuit, then evidently the output that is energized caused the diagnostic detection. The output is de-energized and has its health bit set to FALSE, while the other output of the pair that was de-energized at the detection of the short circuit is considered healthy.

This remains the case as long as the output that was de-energized at the time of detection remains de-energized, however:

- If the unaffected output is energized and a short circuit is still detected while a command to retry is attempted, then both outputs are de-energized and their health bits set to FALSE.
- If instead, the output is returned to a de-energized state prior to a command to retry while the short circuit remains active, the output continues to present a healthy status. It is only if the output is energized and an unsuccessful retry is attempted that the error state is applied to both outputs in the pair.

This behavior is depicted in the following diagram:

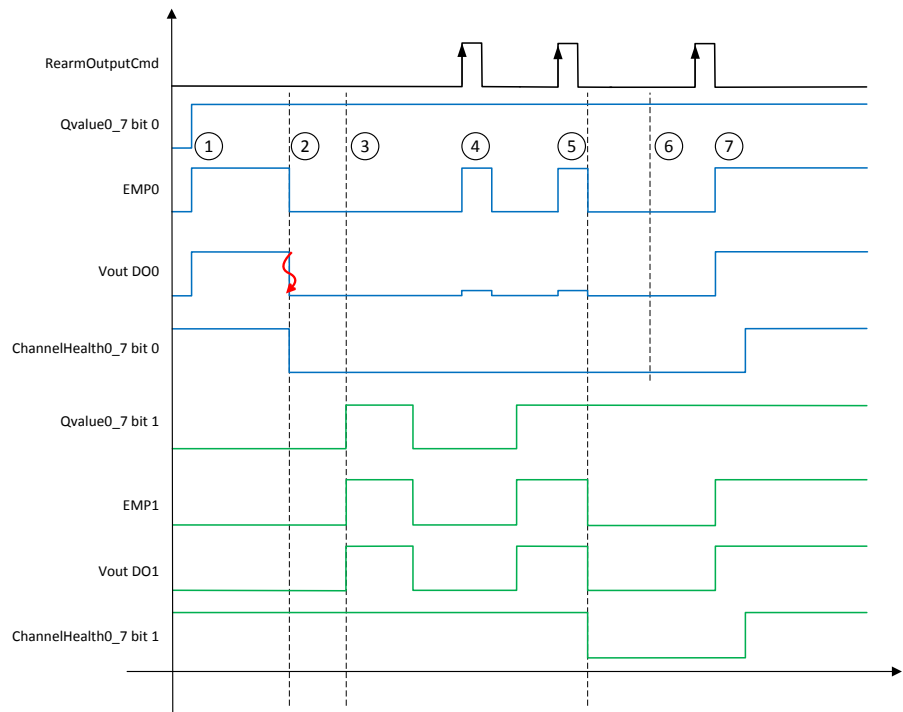

Stage	Description
1	When <i>Qvalue0_7</i> bit 0 is TRUE, the DO0 output is energized (EMP0 is set to TRUE).
2	When a short circuit is detected on output DO0: <ul style="list-style-type: none"> • <i>ChannelHealth0_7</i> bit 0 is set to FALSE. • The DO0 output is de-energized (EMP0 is set to FALSE). NOTE: Since <i>Qvalue0_7</i> bit 1 is FALSE, DO1 is de-energized and <i>ChannelHealth0_7</i> bit 1 keep its present state.
3	In this example, <i>Qvalue0_7</i> bit 1 becomes TRUE, the DO1 output is energized (EMP1 is set to TRUE).
4	A rising edge on <i>RearmOutputCmd</i> starts the retry attempt. The DO0 output is energized (<i>Vout</i> > 0) for a duration of 10 ms + 2 x IO Bus Cycle Time . At the end of the retry attempt duration, the short circuit is still detected, DO0 outputs is de-energized. <i>Qvalue0_7</i> bit 1 is FALSE, DO1 is de-energized during the retry attempt, therefore <i>ChannelHealth0_7</i> bit 1 keeps its present state

5	<p>A rising edge on <i>RearmOutputCmd</i> starts the retry attempt. The DO0 output is energized ($V_{out} > 0$) for a duration of 10 ms + 2 x IO Bus Cycle Time. In this case DO1 is energized during an unsuccessful retry attempt, and at the end of the retry attempt duration:</p> <ul style="list-style-type: none">• ChannelHealth0_7 bit 1 is set to FALSE.• The DO0 and DO1 outputs are de-energized (EMP1 is set to FALSE).
6	<p>The cause of the short circuit is cleared.</p>
7	<p>A rising edge on <i>RearmOutputCmd</i> starts the retry attempt. No short circuit is detected, <i>ChannelHealth0_7</i> bit 0 and bit 1 are set to TRUE at the end of the retry attempt. At this point, normal operation resumes.</p>

Glossary

A

application:

A program including configuration data, symbols, and documentation.

C

configuration:

The arrangement and interconnection of hardware components within a system and the hardware and software parameters that determine the operating characteristics of the system.

controller:

Automates industrial processes (also known as programmable logic controller or programmable controller).

D

derating:

A reduction in an operating specification. For devices in general, it is usually a specified reduction in nominal power to allow operation at increased ambient conditions like higher temperatures or higher altitudes.

E

electronic module:

In a programmable controller system, most electronic modules directly interface to the sensors, actuators, and external devices of the machine/process. This electronic module is the component that mounts in a bus base and provides electrical connections between the controller and the field devices. Electronic modules are offered in a variety of signal levels and capacities. (Some electronic modules are not I/O interfaces, including power distribution modules and transmitter/Extender module).

EN:

EN identifies one of many European standards maintained by CEN (*European Committee for Standardization*), CENELEC (*European Committee for Electrotechnical Standardization*), or ETSI (*European Telecommunications Standards Institute*).

F

FE:

(functional Earth) A common grounding connection to enhance or otherwise allow normal operation of electrically sensitive equipment (also referred to as functional ground in North America).

In contrast to a protective Earth (protective ground), a functional earth connection serves a purpose other than shock protection, and may normally carry current. Examples of devices that use functional earth connections include surge suppressors and electromagnetic interference filters, certain antennas, and measurement instruments.

firmware:

Represents the BIOS, data parameters, and programming instructions that constitute the operating system on a controller. The firmware is stored in non-volatile memory within the controller.

I**input/output:**

The index of the ARRAY.

I/O:

(input/output)

ID:

(identifier/identification)

IEC:

(international electrotechnical commission) A non-profit and non-governmental international standards organization that prepares and publishes international standards for electrical, electronic, and related technologies.

IP 20:

(ingress protection) The protection classification according to IEC 60529 offered by an enclosure, shown by the letter IP and 2 digits. The first digit indicates 2 factors: helping protect persons and for equipment. The second digit indicates helping protect against water. IP 20 devices help protect against electric contact of objects larger than 12.5 mm, but not against water.

Island: : Group of remote or distributed clusters.

L**LED:**

(light emitting diode) An indicator that illuminates under a low-level electrical charge.

M**ms:**

(millisecond)

N**network:**

A system of interconnected devices that share a common data path and protocol for communications.

NTS: *(Network Terminal Slice)*

R

Readback: Readback is the re-reading of the physical output. The readback error is therefore a different reading of the command.

S**sink input:**

A wiring arrangement in which the device provides current to the input electronic module. A sink input is referenced to 0 Vdc.

source output:

A wiring arrangement in which the output electronic module provides current to the device. A source output is referenced to +24 Vdc.

Index

D

Discrete Input Modules

NTSDAI0215H.....	98
NTSDAI0403H.....	110
NTSDAI0404H.....	123
NTSDAI0804.....	133
NTSDDI0402.....	23
NTSDDI0402H.....	23
NTSDDI0602.....	37
NTSDDI0802X.....	48
NTSDDI1602.....	61
NTSDDI1602X.....	73
NTSDDI1602XH.....	73
NTSDDI1642.....	86

Discrete Output Modules

NTSDAO0205.....	231
NTSDAO0415.....	241
NTSDAO0415H.....	241
NTSDDO0212H.....	144
NTSDDO0402.....	156
NTSDDO0402H.....	156
NTSDDO0602.....	167
NTSDDO0802.....	177
NTSDDO0802X.....	187
NTSDDO1602.....	197
NTSDDO1602X.....	209
NTSDDO1602XA.....	220
NTSDDO1602XAH.....	220
NTSDDO1602XH.....	209
NTSDRA0615.....	274
NTSDRC0215.....	251
NTSDRC0415.....	263
NTSDRC0415H.....	263

Schneider Electric
35 rue Joseph Monier
92500 Rueil Malmaison
France

www.se.com

As standards, specifications, and design change from time to time, please ask for confirmation of the information given in this publication.

© 2026 Schneider Electric. All rights reserved.

EIO0000005238.04