

AccuSine PCS+™ Active Harmonic Filter AccuSine PFV+™ Electronic VAR Correction

IP00, IP20, UL Type 1, and UL Type Open

Installation Manual

NHA41798-01
08/2015

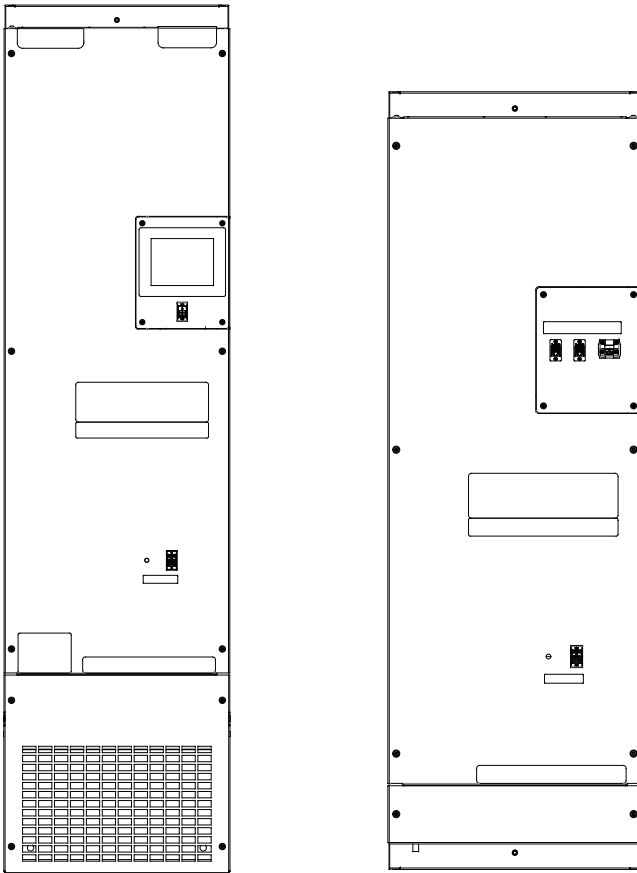

Safety information

Important information



Read these instructions carefully and look at the equipment to become familiar with the device before trying to install, operate, service or maintain it. The following special messages may appear throughout this bulletin or on the equipment to warn of potential hazards or to call attention to information that clarifies or simplifies a procedure.

The addition of either symbol to a “Danger” or “Warning” safety label indicates that an electrical hazard exists which will result in personal injury if the instructions are not followed.

This is the safety alert symbol. It is used to alert you to potential personal injury hazards. Obey all safety messages that follow this symbol to avoid possible injury or death.

DANGER

DANGER indicates a hazardous situation which, if not avoided, **will result in death** or serious injury.

WARNING

WARNING indicates a hazardous situation which, if not avoided, **could result in death** or serious injury.

CAUTION

CAUTION indicates a hazardous situation which, if not avoided, **could result in minor or moderate injury**.

NOTICE

NOTICE is used to address practices not related to physical injury.

Please note

Electrical equipment should be installed, operated, serviced and maintained only by qualified personnel. No responsibility is assumed by Schneider Electric for any consequences arising out of the use of this material.

A qualified person is one who has skills and knowledge related to the construction, installation, and operation of electrical equipment and has received safety training to recognize and avoid the hazards involved.

Legal information

The Schneider Electric brand and any registered trademarks of Schneider Electric Industries SAS referred to in this guide are the sole property of Schneider Electric SA and its subsidiaries. They may not be used for any purpose without the owner's permission, given in writing. This guide and its content are protected, within the

meaning of the French intellectual property code (Code de la propriété intellectuelle français, referred to hereafter as "the Code"), under the laws of copyright covering texts, drawings and models, as well as by trademark law. You agree not to reproduce, other than for your own personal, noncommercial use as defined in the Code, all or part of this guide on any medium whatsoever without Schneider Electric's permission, given in writing. You also agree not to establish any hypertext links to this guide or its content. Schneider Electric does not grant any right or license for the personal and noncommercial use of the guide or its content, except for a non-exclusive license to consult it on an "as is" basis, at your own risk. All other rights are reserved.

Electrical equipment should be installed, operated, serviced and maintained only by qualified personnel. No responsibility is assumed by Schneider Electric for any consequences arising out of the use of this material.

As standards, specifications and designs change from time to time, please ask for confirmation of the information given in this publication.

Chapter 1	Safety precautions	7
Chapter 2	Introduction	9
	Active Harmonic Filter	9
	Electronic VAR Control	9
Chapter 3	Receiving, handling, and storing	11
	Receiving	11
	Inspection	11
	Handling	11
	Storing	12
Chapter 4	Installation	13
	Foundation preparation	14
	Installation	14
	Environmental Requirements	14
	Physical Installation	15
	Standard Units Physical Description	15
	Dimensional Drawings	16
	IP00 60 A and 120 A Drawings	16
	IP20 60 A and 120 A Drawings	21
	200 A and 300 A Drawings	25
	Electrical Connection	33
	Line Voltage	33
	Over-current Protection Device Selection	33
	Power Cable Routing	33
	Power and Ground Cable Selection and Connections	34
	60 A Models	35
	120 A Models	36
	200 A and 300 A Models	38
	Current Transformers (CTs)	39
	General CT Information	39
	Minimum CT Requirements	40
	CT to CT Board Connection	41
	Parallel System	45
	CT Installation Parallel Units	45
	Parallel Communication	50
	Control Wiring	51
	Dry Contact output	51
	Digital Input Control	51
	Modbus TCP/IP	51
	Modbus Serial	52
Chapter 5	UL Type 1/IP20 Conversion Kit Assembly (Optional)	55
	Prepare the active filter chassis for UL Type 1/IP20 Conversion Kit	56
	Connect the HMI ground wire to the chassis	58
	Attach the HMI to the HMI mounting plate	59
	Connect the USB jack to the HMI mounting plate	60
	HMI Power wiring	60
	Installation of the HMI assembly in the Chassis	61
	Attaching the Wall Mount Kit to the Chassis for 60 A and 120 A Units	62
	Attaching the Wall Mount Kit to the Chassis for 200 A and 300 A Units	63
Chapter 6	Pre-commissioning	65

- Instruments required for commissioning 65
- Pre-energizing procedure 65
 - Installation Inspection 65
- Pre-Commissioning Checklist 66
- Commissioning procedures 66
- Chapter 7 IT, HRG, and Corner Grounded Systems 67**
- Chapter 8 IP00 chassis in a customer supplied enclosure 71**
 - HMI Connections 75
 - 24 volt power 75
 - Ethernet 75
 - Communication 75
 - Enclosure mount USB 75
 - Dimensional Drawings 76

Chapter 1 Safety precautions

Installation, wiring, testing and service must be performed in accordance with all local and national electrical codes.

DANGER

HAZARD OF ELECTRIC SHOCK, EXPLOSION, OR ARC FLASH

- Apply appropriate personal protective equipment (PPE) and follow safe electrical work practices. See NFPA 70E in the USA, CSA Z462, or applicable local standards.
- This equipment must be installed and serviced only by qualified electrical personnel.
- Do not exceed the device's ratings for maximum limits.
- Ground equipment using the ground connecting point provided before turning on any power supplying this device.
- Turn off all power supplying this device and the equipment in which it is installed before working on the device or equipment.
- After removing power, wait for 15 minutes to allow the capacitors to discharge prior to opening the doors or removing covers.
- Always use a properly rated voltage sensing device to confirm power is off.
- Replace all devices, doors, and covers before turning on power to this equipment.
- Carefully inspect the interior for tools left behind before closing and sealing the door.

Failure to follow these instructions will result in death or serious injury.

Chapter 2 Introduction

The product can be provided in either of two types, an Active Harmonic Filter (AHF) or an Electronic VAR Control (EVC). Both types are to be installed as described in this manual. These products are both referred to as an active filter in this manual.

Active Harmonic Filter

Active Harmonic Filters (AHF) are static power electronic products that employ digital logic and IGBT semiconductors to synthesize a current waveform that is injected into the electrical network to cancel harmonic currents caused by nonlinear loads. AHF employ current transformers to measure the load current to determine the content of harmonic current present. By injecting the synthesized current, network harmonic currents are greatly mitigated, thus reducing the heating effects of harmonic current and reducing voltage distortion.

AHF also have the ability to correct for poor displacement power factor (DPF) and for mains current balancing. DPF correction can be provided for either leading (capacitive) or lagging (inductive) loads that cause poor DPF. Mains current balancing is achieved by measuring the negative sequence current present and injecting the inverse negative sequence current to balance the current for the upstream network.

Multiple enclosure styles are available. IP00 open chassis designs can be installed in other types of enclosures such as motor control centers (MCC).

Electronic VAR Control

Electronic VAR control (EVC) are static power electronic products that employ digital logic and IGBT semiconductors to synthesize a current waveform that is injected into the electrical network to cancel load induced poor displacement power factor (DPF), phase current unbalance, and flicker. DPF correction can be provided for either leading (capacitive) or lagging (inductive) loads that cause poor DPF. Mains current balancing is achieved by measuring the negative sequence current present and injecting the inverse negative sequence currents to balance the current for the network. Flicker control is provided by rapid detection and injection of reactive current (VARs) to prevent the reactive current from over loading the network that causes rapid voltage deviations identified as flicker.

EVC also have the ability to monitor the network voltage on which they are connected and determine the proper amount of VARs to either raise the network voltage or lower it. EVC will inject leading VARs to raise the voltage and lagging VARs to lower the voltage. Entry of appropriate parameters will keep the network within its stated voltage tolerance level.

Multiple enclosure styles are available. IP00 open chassis designs can be installed in other types of enclosures such as motor control centers (MCC).

Chapter 3 Receiving, handling, and storing

Receiving

Inspect the active filter for any damage as soon as it is received. Transfer of the equipment to a carrier at any manufacturing plant or other shipping point constitutes delivery to the purchaser. Title and all risk of loss or damage in transit shall pass to the purchaser at that time, regardless of freight payment.

Inspection

- Check that all packages and/or crates have been delivered and that the equipment has not been damaged in transit.
- On the outside packaging and inside the unit, Drop N Tell monitoring devices are installed. If these have been activated, inform the carrier immediately.



- In the event of damaged or missing items, contact the carrier immediately. Check with them for time limits for filing claims and any documentation required such as a Bill of Lading number, etc.
- Goods, whether sent freight pre-paid or not, are shipped at the consignee's risk.
- Damaged or missing items are the responsibility of the carrier and must be reported.
- Check that the information shown on the equipment nameplates corresponds with the order specifications.
- The packaging material should be replaced to protect the unit until installation has begun.

Handling

⚠ WARNING
<p>HAZARD OF PERSONAL INJURY</p> <ul style="list-style-type: none"> • Use proper lifting equipment such as an overhead crane to handle the active filter. • Do not lay the equipment on its front. <p>Failure to follow these instructions can result in death, serious injury, or equipment damage.</p>

Ensure that the proper equipment such as an overhead crane is available at the installation site to handle the active filter. This equipment will help avoid injury to personnel and damage to the active filter.

Verify the lifting capacity of the equipment being used to handle the active filter in accordance with the shipping weight of each shipping section.

Storing

If the active filter is not to be installed when unpacked, it should be stored indoors in a clean, dry place. The storage temperature must be between -20°C (-4°F) and 60°C (140°F) with a maximum relative humidity of 85%, non-condensing, and a maximum dewpoint of 37°C. It is preferable to store the unit in its original shipping container to protect the unit from potential damage.

Chapter 4 Installation

This chapter provides the information required to properly install the active filter and associated equipment for proper operation and performance. Frequently, commissioning difficulties are the result of incorrect wiring. Every precaution must be taken to assure that the wiring is done as instructed. Read and understand all instructions in this manual prior to installation.

Correct installation of the active filter is essential for proper operation of all components. Study the associated instruction books and all drawings carefully.

The location chosen for installation should provide working clearances complying with the appropriate section of the National Electrical Code® (NEC®), the Canadian Electrical Code (CEC), or applicable local standards.

DANGER

HAZARD OF ELECTRIC SHOCK, EXPLOSION, OR ARC FLASH

- Apply appropriate personal protective equipment (PPE) and follow safe electrical work practices. See NFPA 70E in the USA, CSA Z462, or applicable local standards.
- This equipment must be installed and serviced only by qualified electrical personnel.
- Do not exceed the device's ratings for maximum limits.
- Ground equipment using the ground connecting point provided before turning on any power supplying this device.
- Turn off all power supplying this device and the equipment in which it is installed before working on the device or equipment.
- Do not stand on any part of the active filter.
- After removing power, wait for 15 minutes to allow the capacitors to discharge prior to opening the doors or removing covers.
- Always use a properly rated voltage sensing device to confirm power is off.
- Replace all devices, doors, and covers before turning on power to this equipment.
- Carefully inspect the interior for tools left behind before closing and sealing the door.

Failure to follow these instructions will result in death or serious injury.

The following is a summary of the steps for installation covered in this chapter:

1. Ensure that the line voltage is compatible with the voltage rating of the active filter.
2. Ensure the foundation is prepared for the active filter.
3. Ensure that environmental requirements are satisfied.
4. Refer to the dimensional drawings for the active filter to be installed.
5. Mount the unit in the desired location.
6. Make the electrical connections.
7. Make the CT to CT board connection.
8. Set up parallel communication if applicable.

9. When installing on Isolated Terra (IT), High Resistance Ground (HRG), or corner grounded systems, ensure that the IT/BP switches are open. Refer to “IT, HRG, and Corner Grounded Systems” on page 67.
10. Make the control wiring connections, but do not energize the active filter yet.

NOTE: Commissioning and energizing the active filter requires specialized knowledge. Pre-commissioning procedures are covered in “Pre-commissioning” on page 65. Commissioning procedures are covered in the User Manual. Commission the active filter and energize it only if you are qualified to do so.

Foundation preparation

The mounting location must be able to support the weight of the unit without sagging. Weight specifications are provided in “Open/IP00 and UL Type 1/IP20 Enclosures Physical Specifications” on page 15.

Installation

For optimum performance in harmonic mitigation mode, adhere to the following recommendations:

- All harmonic generating loads must have a minimum 3% line reactor or 3% DC choke installed.
- SCR based rectifiers are required to have a minimum 3% line reactor.
- No capacitors downstream of the Main CTs.

NOTICE

RISK OF EQUIPMENT DAMAGE

Adhere to DC choke, SCR based rectifier, and capacitor placement requirements.

Failure to follow this instruction can result in equipment damage.

If these recommendations are not followed, the target harmonic level may not be met and equipment damage can occur.

Environmental Requirements

Active filters are designed for indoor use only. They require unrestricted exchange of environmental air to the inside of the enclosure for proper cooling. Ensure that the environment meets Pollution Degree 2, i.e., does not contain conductive particles, significant amounts of dust, or corrosive or otherwise harmful gases. Normally only non-conductive pollution occurs. Temporary conductivity caused by condensation is to be expected.

NOTICE

RISK OF EQUIPMENT DAMAGE

Ensure that the installation location satisfies environmental requirements.

Failure to follow this instruction can result in equipment damage.

If environmental requirements are not adhered to, malfunction and possible destruction of the active filter may occur.

The active filter generates significant heat during operation. Consult the product specifications in “Electrical Specifications 60, 120, 200 and 300 A Units” on page 34 for the watt losses for each active filter model. Ensure that the room where the active filter is mounted has adequate ventilation. Maintain ambient temperature between 0°C (32°F) and 40°C (104°F) with a maximum relative humidity of 95%, non-condensing, and a maximum dewpoint of 37°C.

The operating temperatures are maximum and minimum levels the unit is designed to operate within. Operating above or below these levels will result in the unit either shutting down or reduced performance. The upper or lower limit should not be used as ideal room temperature levels. System reliability and product life expectancy will improve if temperature levels are maintained between 20°C (68°F) and 30°C (86°F).

Physical Installation

The active filter is provided standard as a UL open/IP00 chassis unit. The unit can be converted to a UL Type 1/IP20 with an optional conversion kit. The following table describes each type.

Enclosure Type	Open/IP00	UL Type 1/ IP20
Enclosure provided	No	Yes
Standard Compliance: UL Type	Open	Type 1
Standard Compliance: IEC529	IP00	IP20
Unrestricted air exchange, protection against contact with enclosed parts, protection against limited amount of falling dirt, intake of dust, and harmful particles	No	Yes
Complete protection against touch and protection against dust deposits	No	Yes
Protection against dripping water and external condensation of non-corrosive liquids	No	No
EMC/RFI certification	Yes	Yes

NOTE: This list indicates minimum requirements. Complete descriptions of the requirements are provided in the standards referenced in this list.

Standard Units Physical Description

Open/IP00 and UL Type 1/IP20 Enclosures Physical Specifications

Active filter	Cable Entry	Heat Load (kW)	Weight Kg (lbs)		Exterior Dimensions H x W x D mm (inches)	
			Open/IP00	UL Type 1/IP20	Open/IP00	UL Type 1/IP20
60 A	Bottom	1.3	90 (198)	100 (220)	1300 x 426 x 348 (51.2 x 16.8 x 13.7)	1534 x 426 x 348 (60.4 x 16.8 x 13.7)
120 A	Bottom	2.8	112.5 (247.5)	122 (268)	1400 x 426 x 384 (55.1 x 16.8 x 15.1)	1634 x 426 x 384 (64.3 x 16.8 x 15.1)
200 A	Bottom	5.4	175 (385)	184 (409)	1323 x 581 x 438 (52.1 x 22.9 x 17.2)	1598 x 581 x 438 (62.9 x 22.9 x 17.2)
300 A	Bottom	7.1	220 (484)	229 (504)	1560 x 581 x 438 (61.4 x 22.9 x 17.2)	1835 x 581 x 438 (72.2 x 22.9 x 17.2)

NOTE:

- Wall mounted units (UL Type 1/IP20) require 305 mm (12 inches) of top clearance.

- Weight information is approximate and subject to change without notice.
- Lifting lugs are provided for hoisting.

Dimensional Drawings

Refer to the drawings on the following pages for dimensions of the active filter to be installed.

IP00 60 A and 120 A Drawings

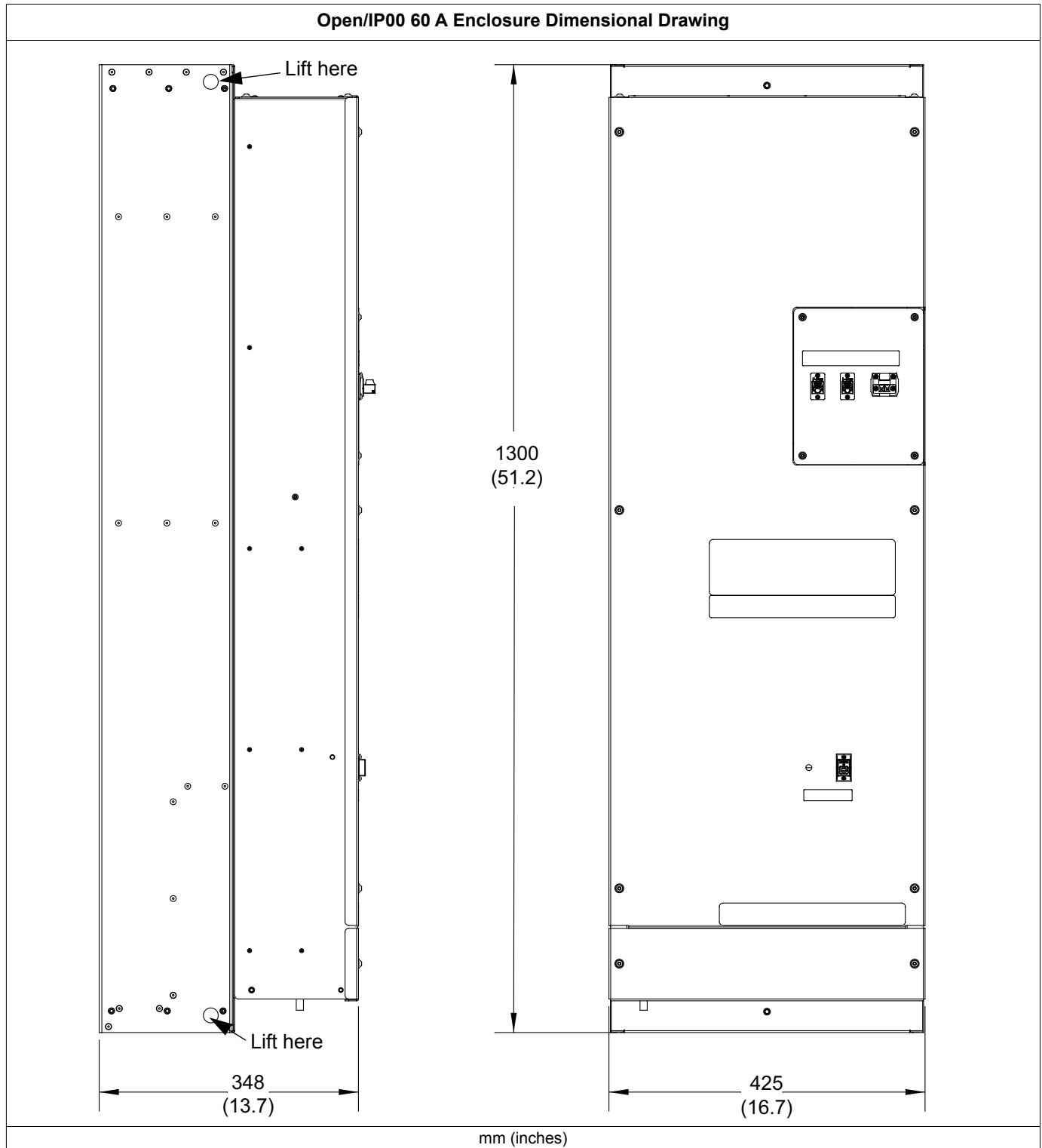

Open/IP00 60 A Enclosure Top and Bottom Dimensional Drawing

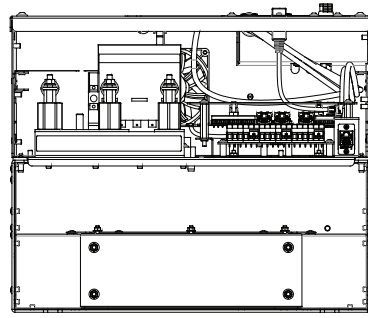
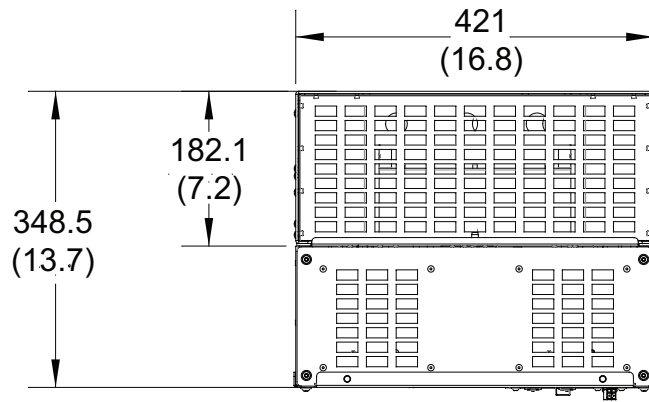

mm (inches)

IP00 120 A Enclosure Dimensional Drawing

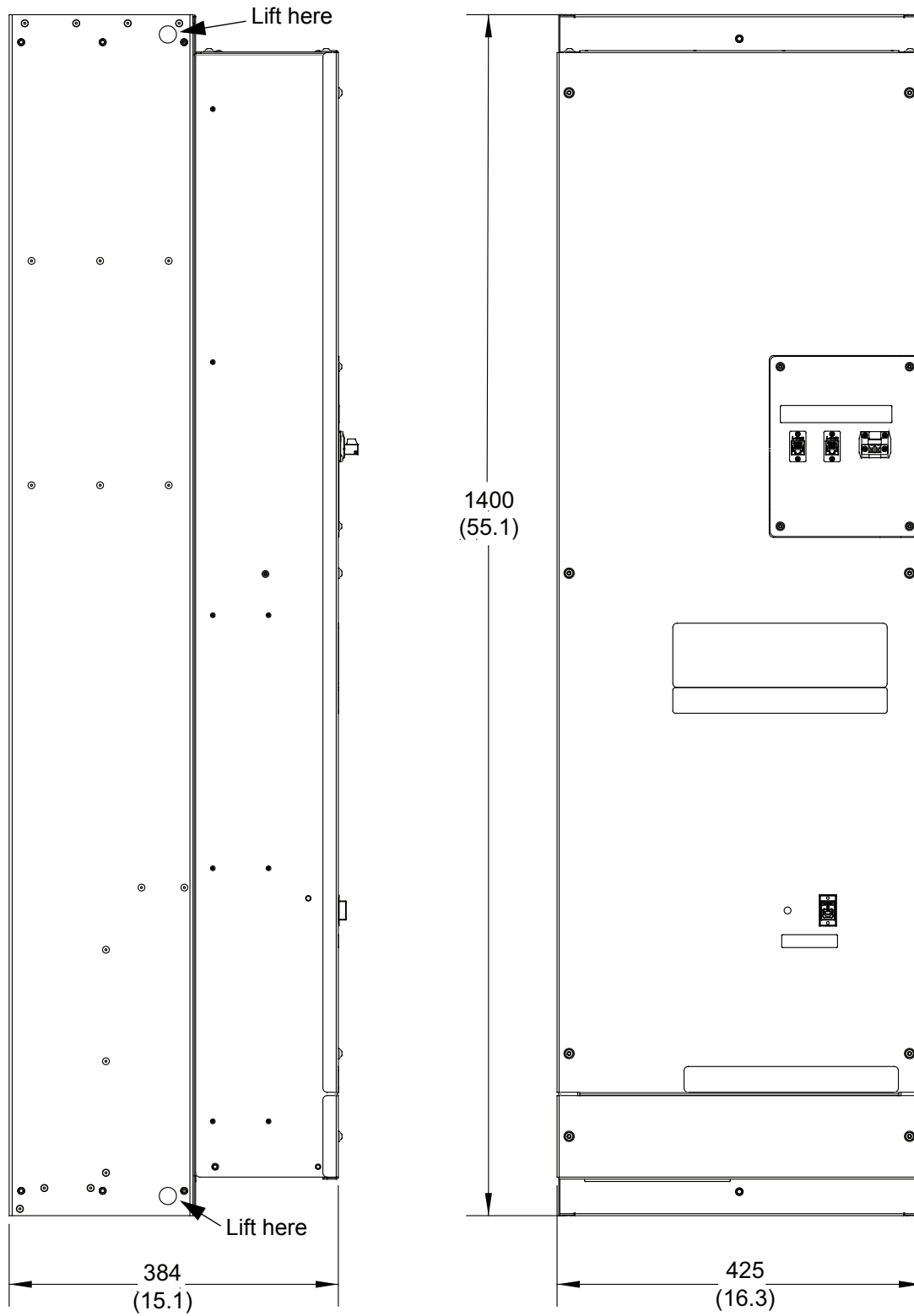

mm (inches)

IP00 120 A Enclosure Top and Bottom Dimensional Drawing

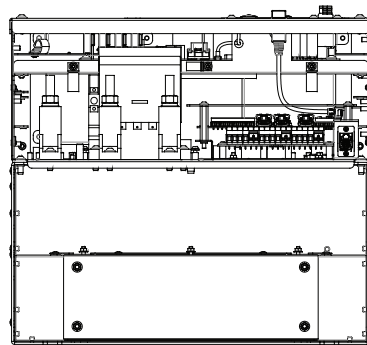
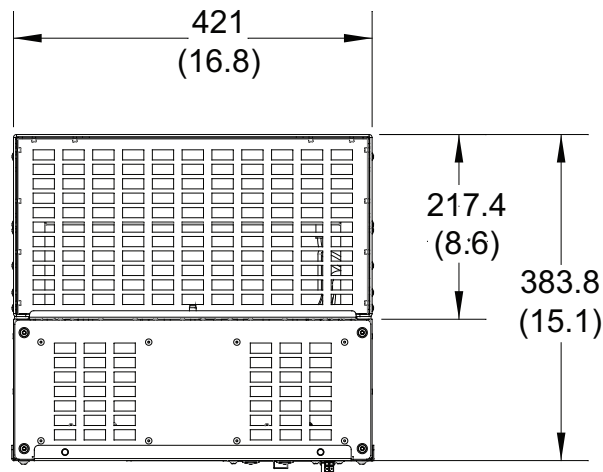

mm (inches)

60A and 120A IP00/IP20 Mounting Dimensions

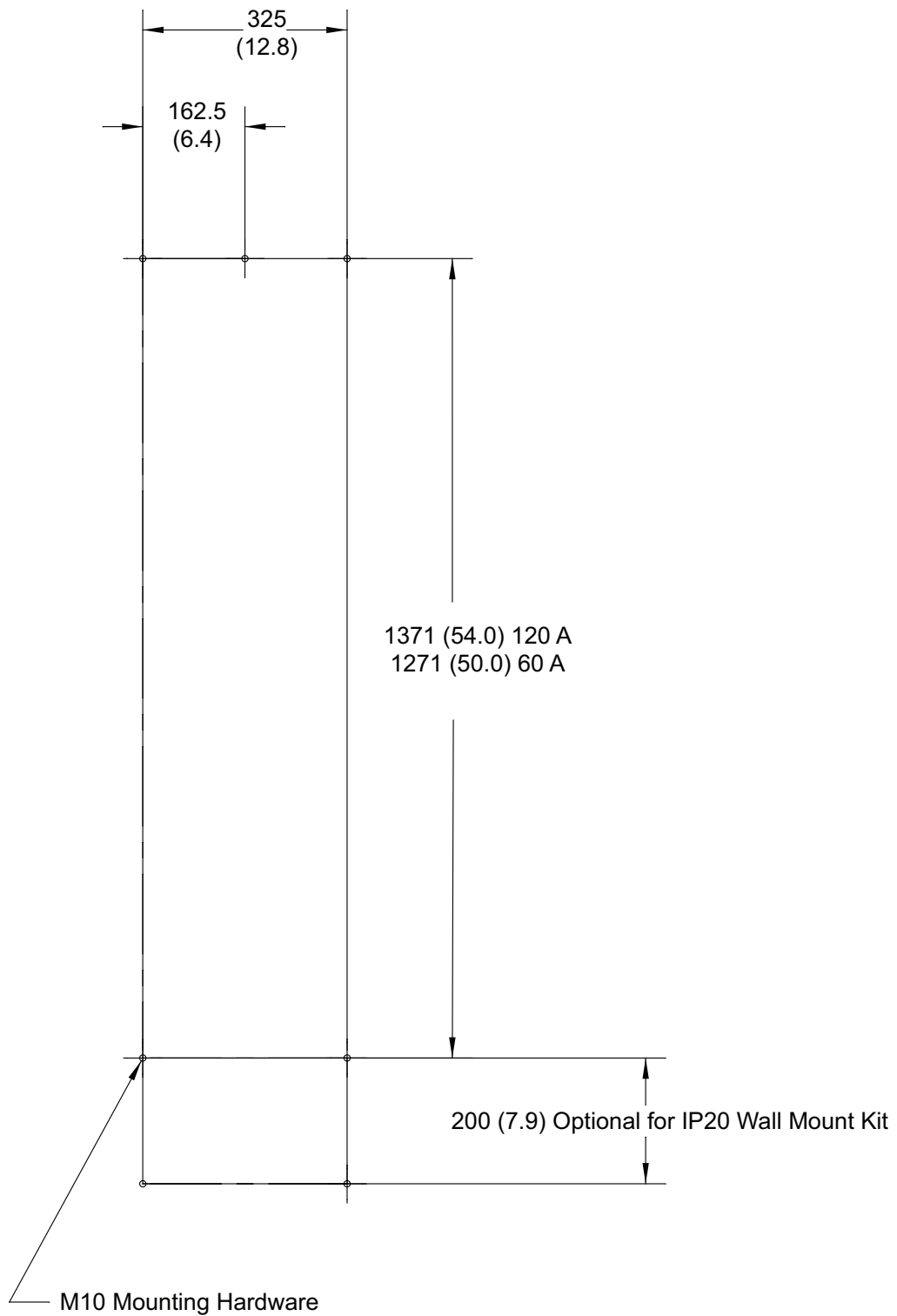

mm (inches)

IP20 60 A and 120 A Drawings

UL Type 1/IP20 60 A Enclosure Dimensional Drawing

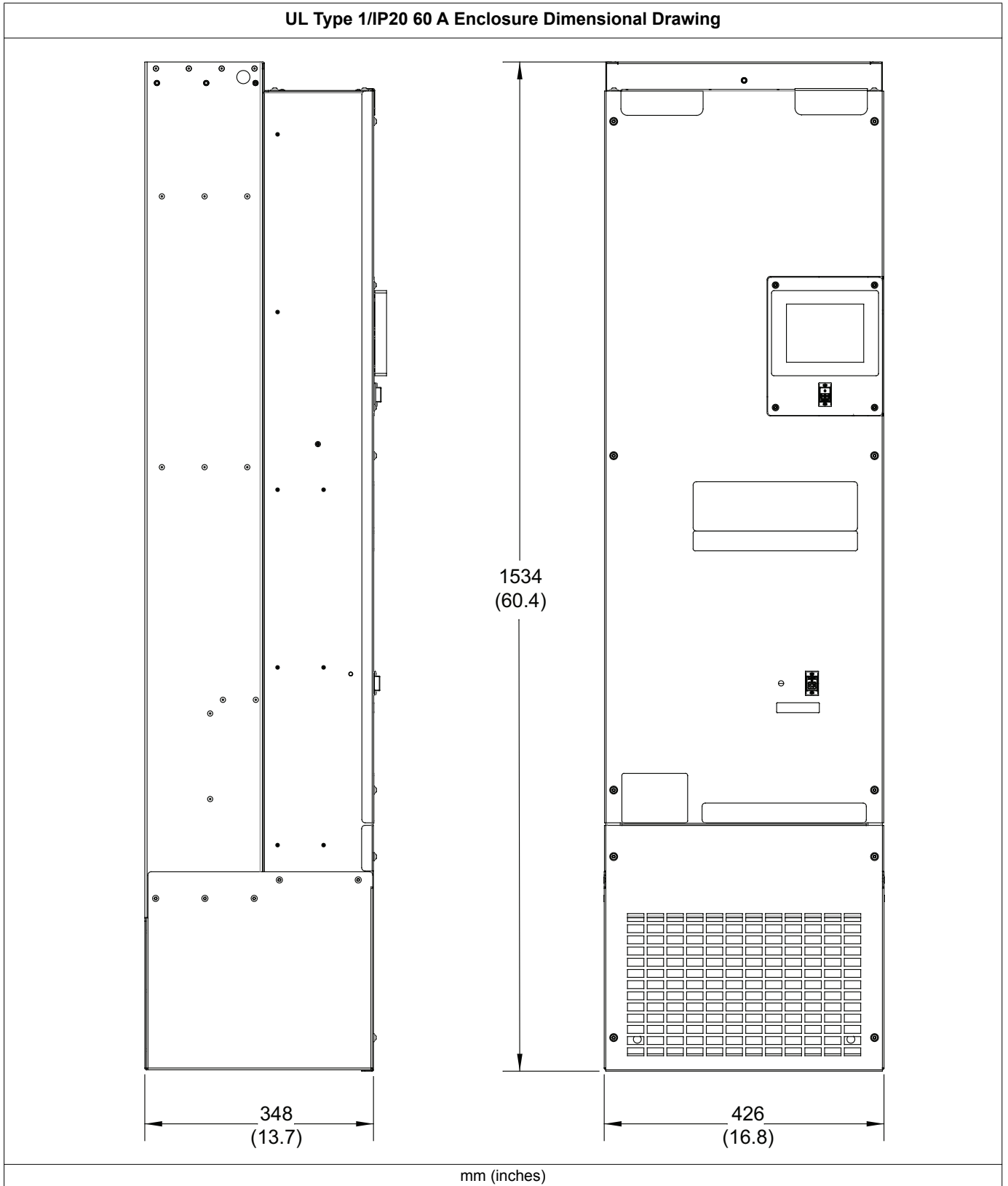

UL Type 1/IP20 60 A Enclosure Top and Bottom Dimensional Drawing

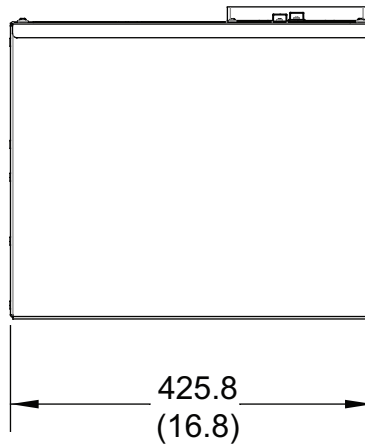
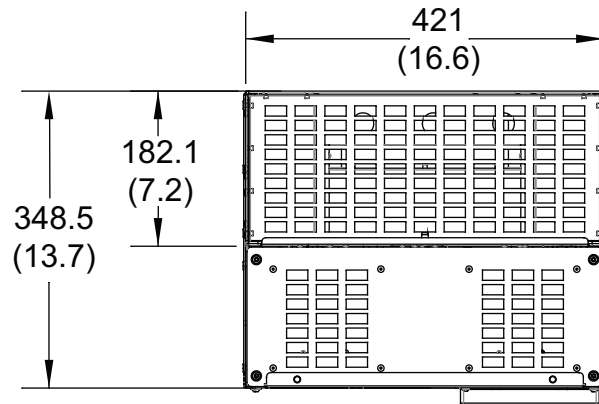

mm (inches)

IP20 120 A Enclosure Dimensional Drawing

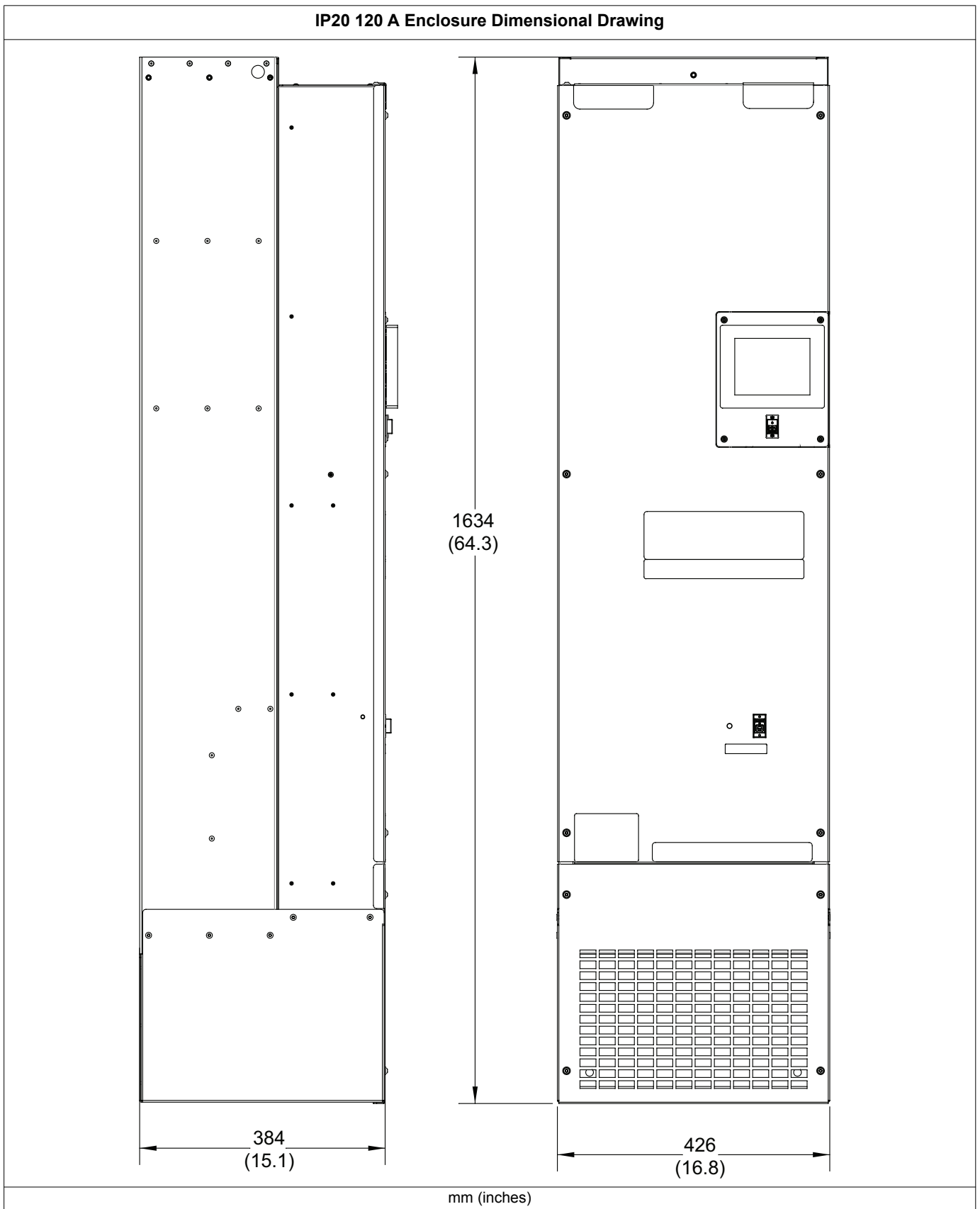

IP20 120 A Enclosure Top and Bottom Dimensional Drawing

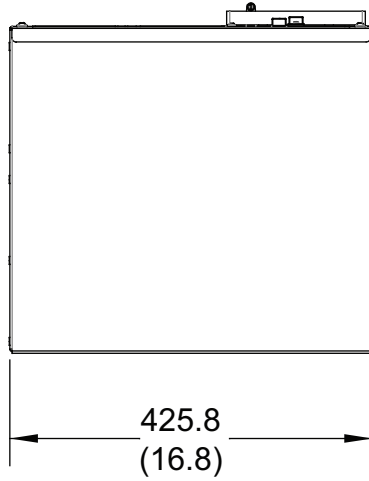
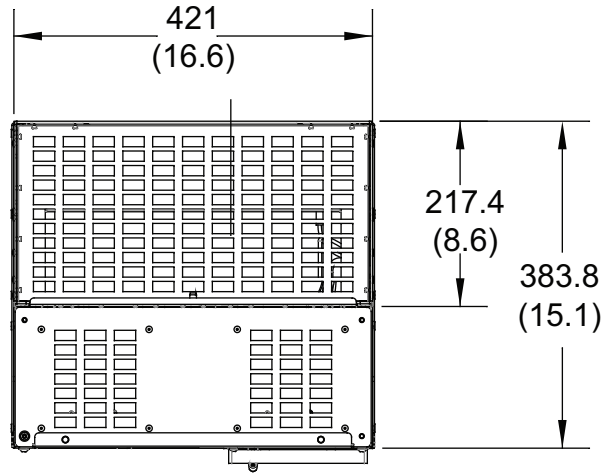

mm (inches)

200 A and 300 A Drawings

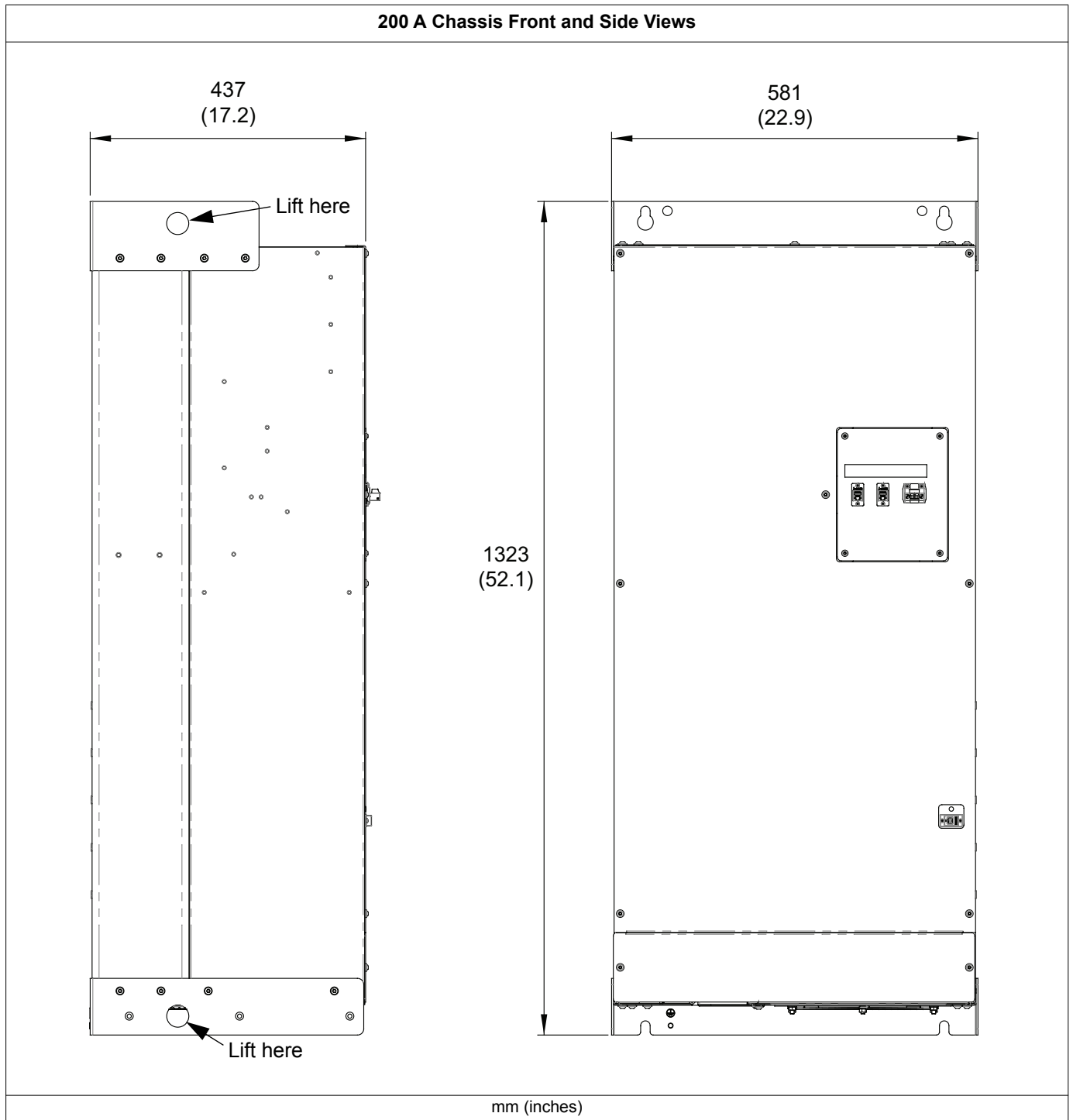

300 A Chassis Front and Side Views

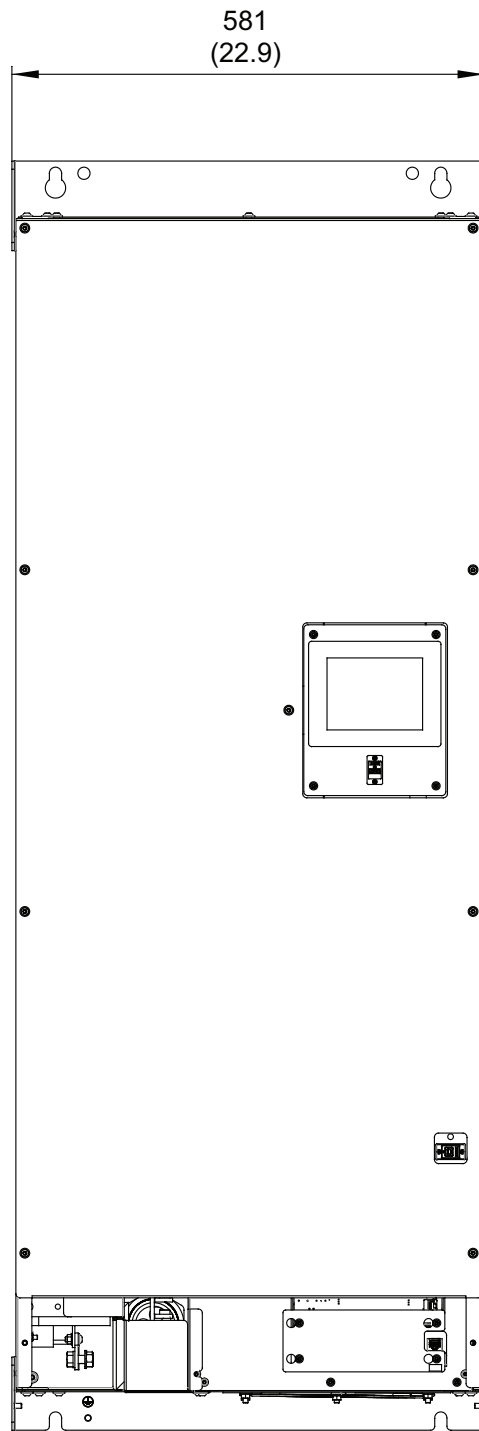
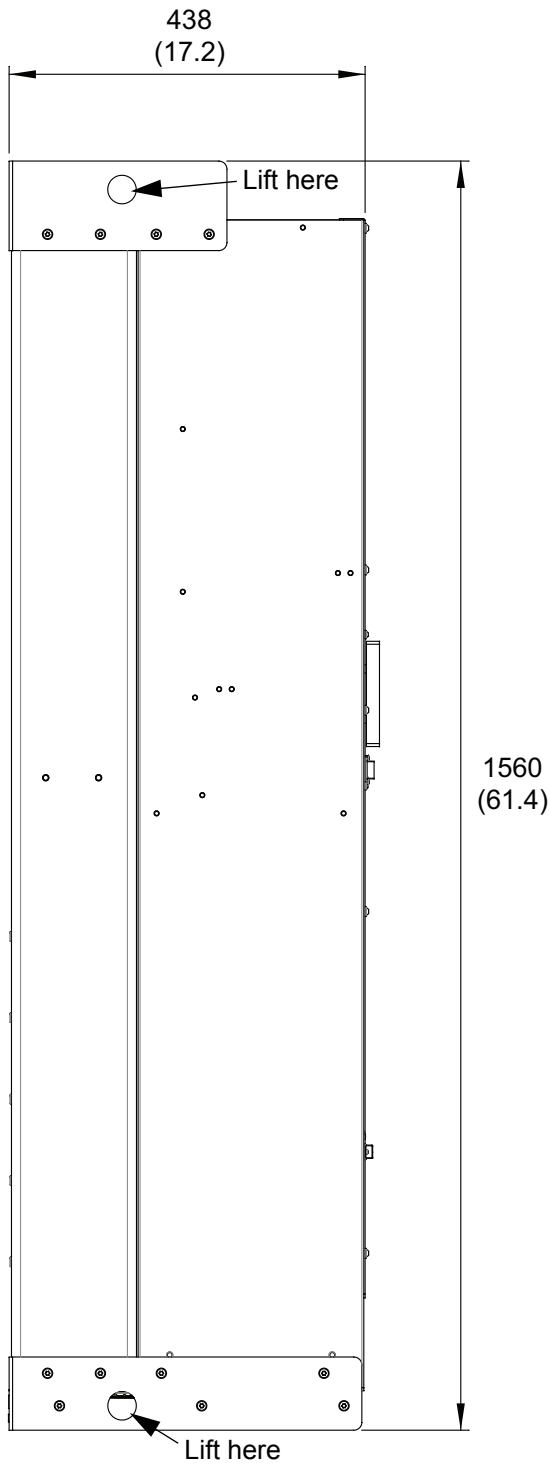

mm (inches)

Open/IP00 200 A and 300 A Top and Bottom Dimensional Drawing

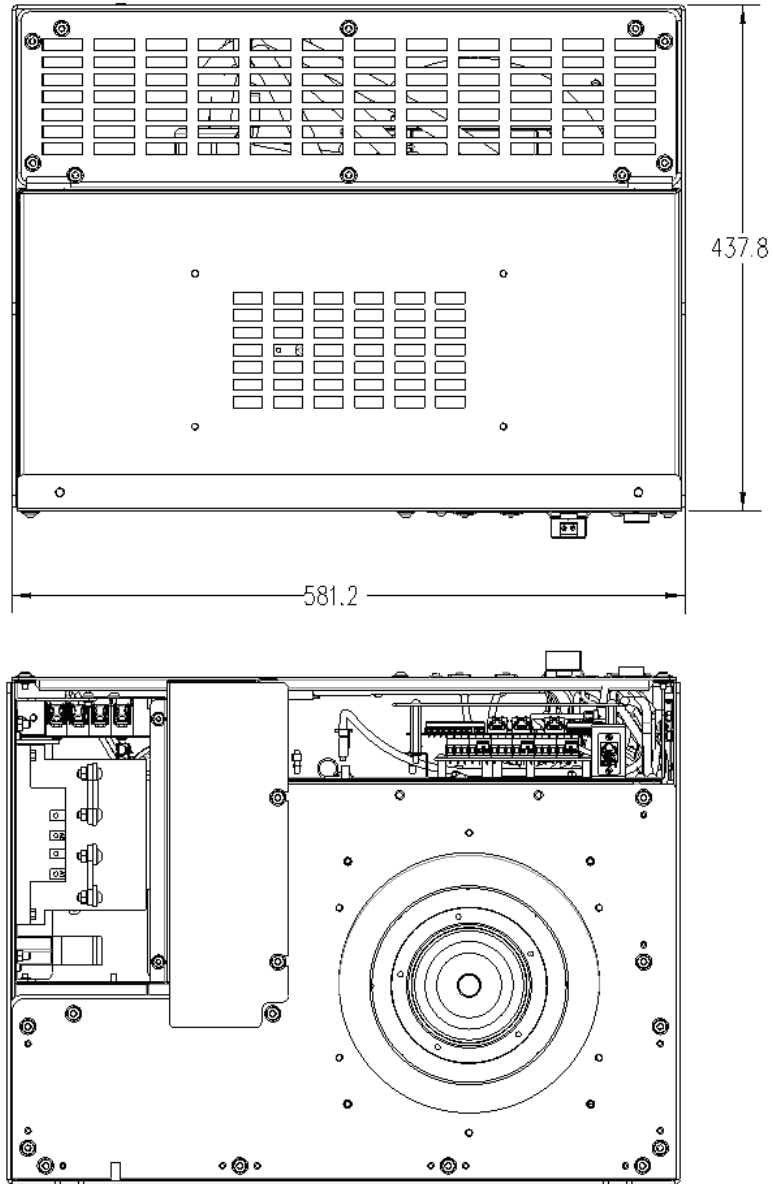

Dimensions are shown in mm.

200 A IP20 Front and Side Views

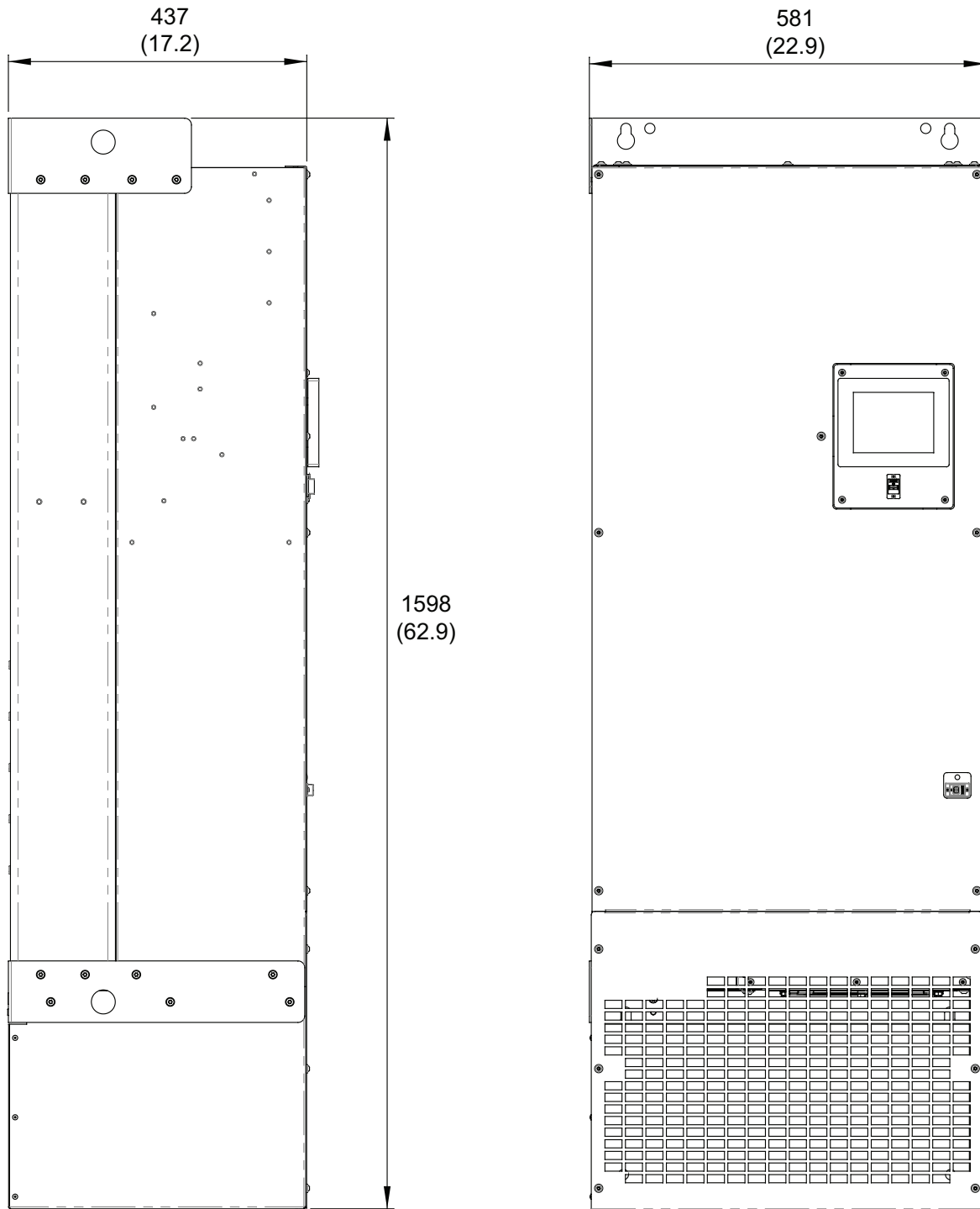

mm (inches)

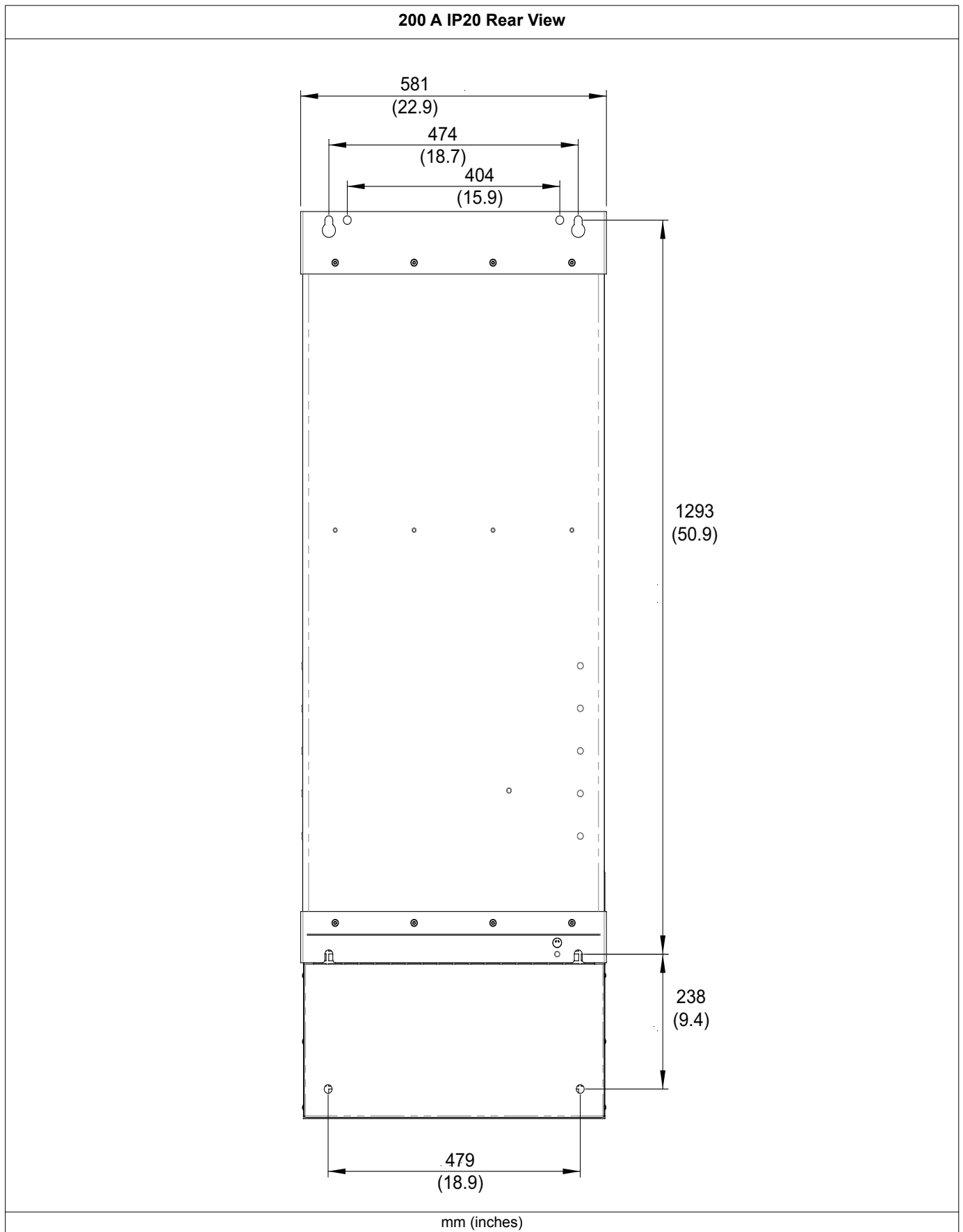

300 A IP20 Front and Side Views

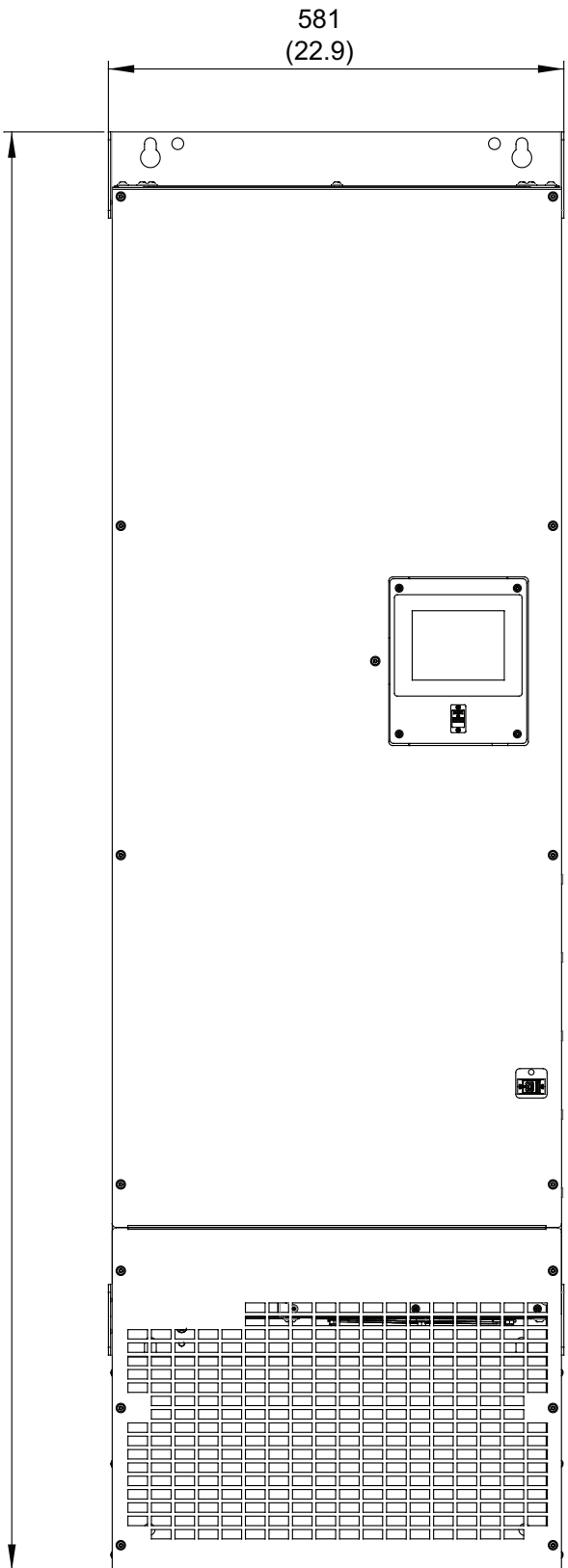
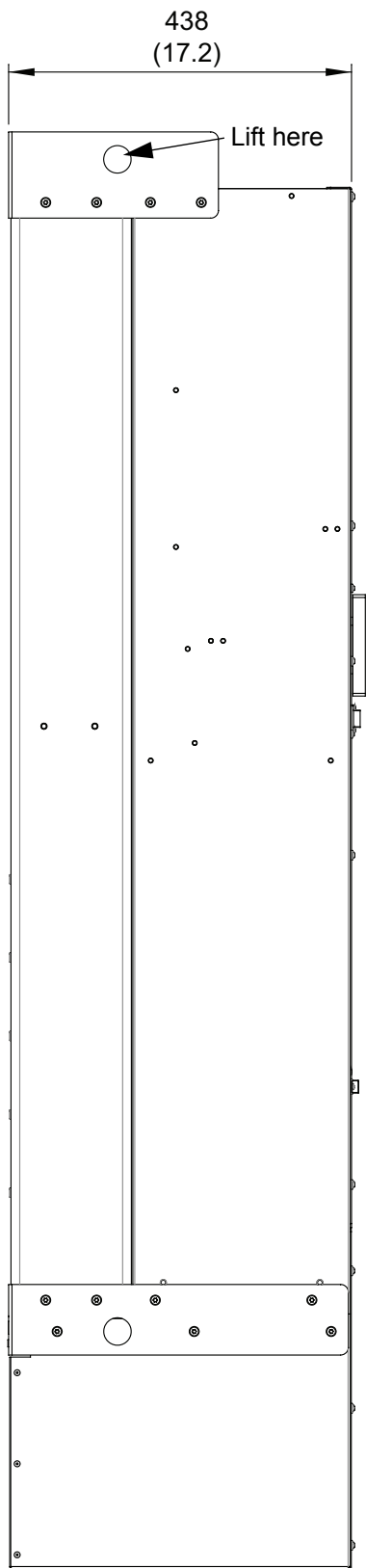

mm (inches)

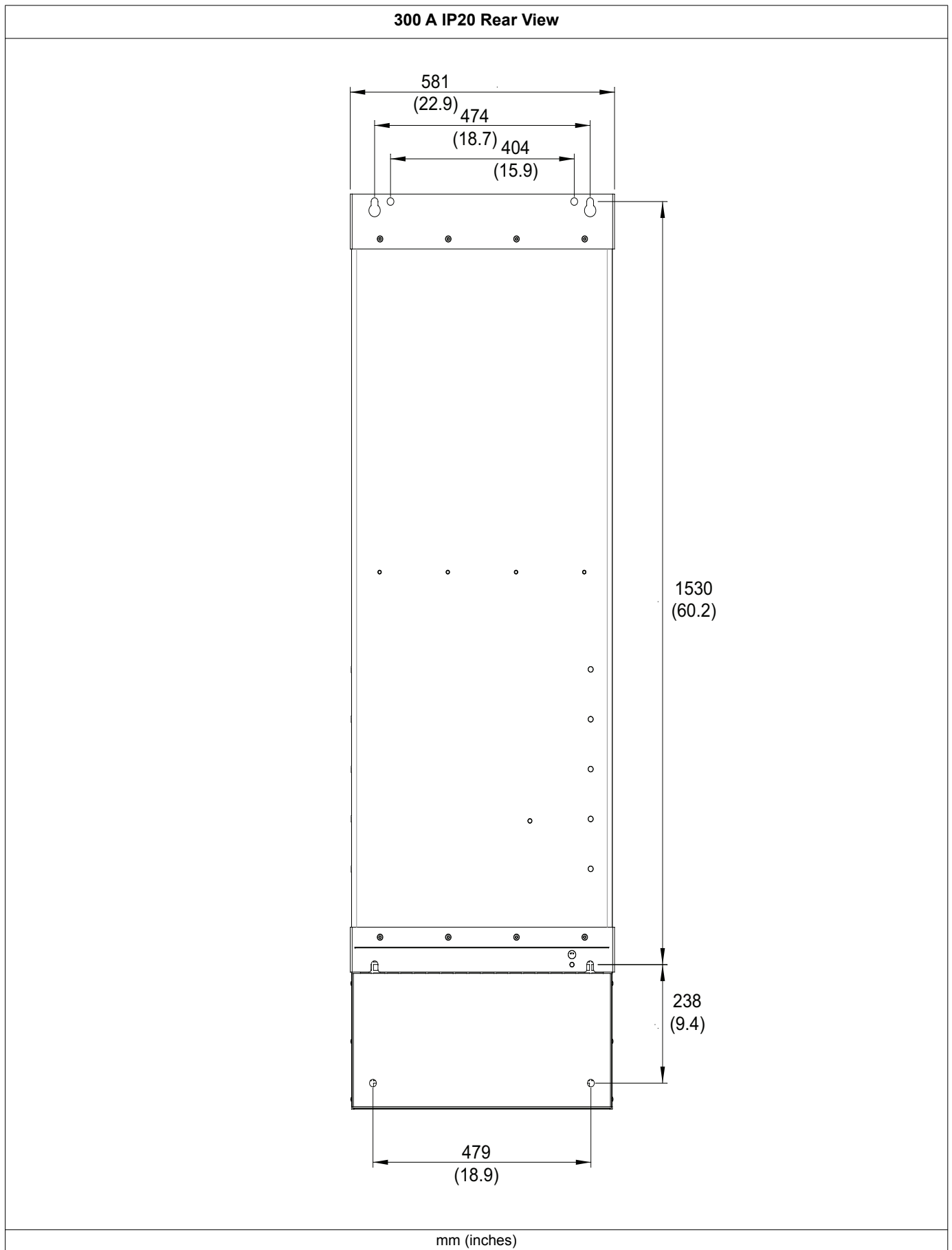

UL Type1/IP20 200 A and 300 A Top and Bottom Dimensional Drawing

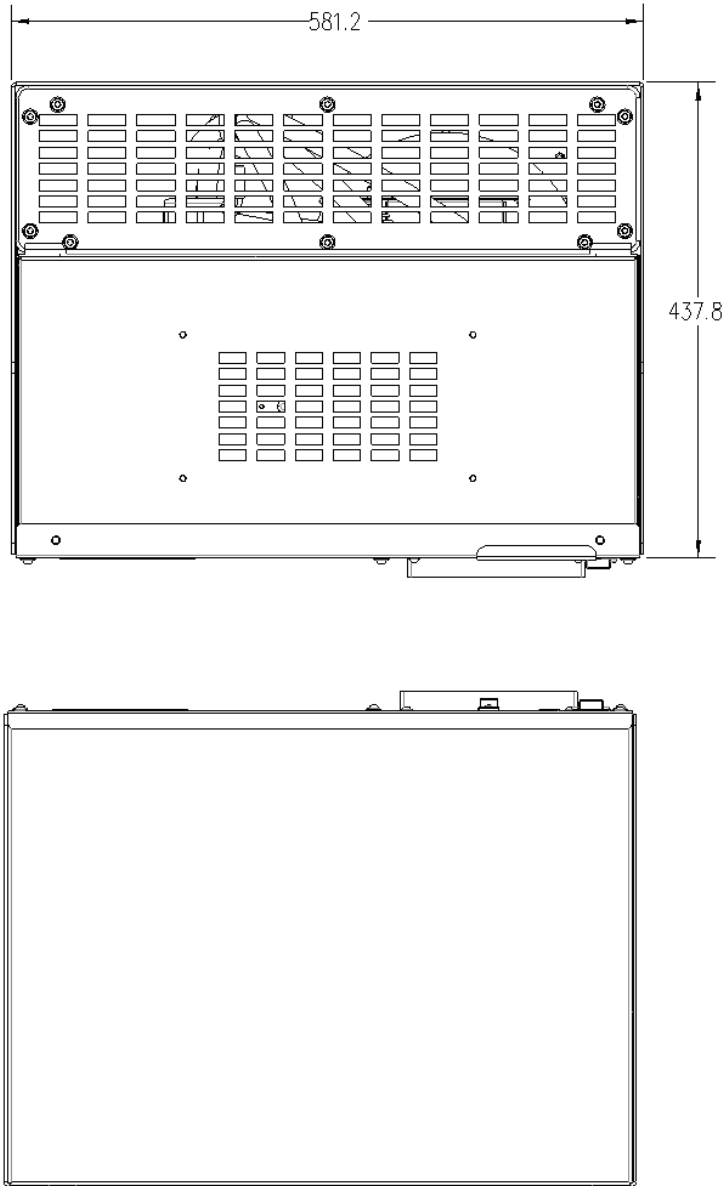

Dimensions are shown in mm.

Electrical Connection

Line Voltage

Refer to “Electrical Specifications 60, 120, 200 and 300 A Units” on page 34 to determine the line voltage that is compatible with the voltage range of the active filter.

Over-current Protection Device Selection

A dedicated over-current protection device, circuit breaker, or fuse disconnect is required for this product. The over-current protection device must be rated for at least 125% of the unit rating.

The active filter inrush current does not exceed the unit rating shown in the following table. Circuit breaker settings such as Long Time Pickup, Long Time Delay, and Short Time Pickup can be set for minimum inrush current.

Unit Rating	Minimum Circuit Ampacity	Minimum Allowable Fuse / Circuit Breaker Size	Maximum Allowable Fuse / Circuit Breaker Size
60 A	60 A	75 A	100 A
120 A	120 A	150 A	150 A (UL) / 160 A (IEC)
200 A	200 A	250 A	250 A
300 A	300 A	400 A	400 A

NOTE: Check national and local codes and regulations to ensure compliance.

Power Cable Routing

Power cables connected to the active filter must be placed in metal conduit or be shielded encapsulated cables to reduce noise coupling (EMI). For Open/IP00 units, power cable connections are at the bottom of the unit. For UL Type 1/IP20, see detail drawings in “UL Type 1/IP20 Conversion Kit Assembly (Optional)” on page 55.

See “Open/IP00 60 A Enclosure Top and Bottom Dimensional Drawing” on page 17 and “IP00 120 A Enclosure Top and Bottom Dimensional Drawing” on page 19.

For all power systems, observe the following:

- Metal conduit or the encapsulated cable shield has to be grounded to the active filter ground-terminal located adjacent to the power terminals.
- All panels must be installed to ensure proper system cooling.

Power and Ground Cable Selection and Connections

DANGER

HAZARD OF ELECTRIC SHOCK, EXPLOSION, OR ARC FLASH

- The unit must be properly grounded before power is applied.
- Ground equipment using the ground connecting point provided.

Failure to follow these instructions will result in death or serious injury.

All power wiring has to be routed directly from the conduit entry plate to the terminations on power terminals (and the earth grounding terminal) without loops. Instrumentation and CT wiring has to be routed in a separate grounded metal conduit or shielded encapsulated cable. A dedicated ground conductor must be used when installing the active filter.

When used as a harmonic current compensation device, the active filter produces currents at frequencies that are multiples of the AC line fundamental frequency. Power cables as well as input disconnect devices should be rated at 125% of the active filter rated current. This helps avoid excessive heating from any skin effect resistance increase at these higher frequencies.

NOTE: Check national and local codes and regulations to ensure compliance.

Box lug accessory kits are available as an option in the catalog. The box lugs are UL compliant. Each kit contains three box lugs for the phase connection and one box lug for the ground connection. When installing 200 A or 300 A units, two box lug kits are required per unit if two conductors per phase are used.

The box lugs in the optional accessory kit are not IEC compliant. For IEC installation, use crimp-on ring lugs for electrical connections.

Electrical Specifications 60, 120, 200 and 300 A Units

Active Filter	Total Current Amperes	Voltage Range Volts	Wire Temperature Rating	Power Connection Type	Power Connection Torque N•m (lb-in) ± 5%	Ground Connection Stud Size	Ground Connection Torque N•m (lb-in) ± 5%	No. Conductors Per Phase
60 A	60	380 - 480	60°C, 75°C, 90°C	M6 Stud	7.5 (66.4)	M8	18.2 (161.1)	1
120 A	120	380 - 480	75°C, 90°C	M8 Stud	18.2 (161.1)	M8	18.2 (161.1)	1
200 A	200	380 - 480	75°C, 90°C	10 mm Hole	36.5 (323.1)	M8	18.2 (161.1)	1 or 2
300 A	300	380 - 480	75°C, 90°C	10 mm Hole	36.5 (323.1)	M8	18.2 (161.1)	1 or 2

NOTE: Check national and local codes and regulations to ensure compliance.

60 A Models

60 A IP00 Customer Connections

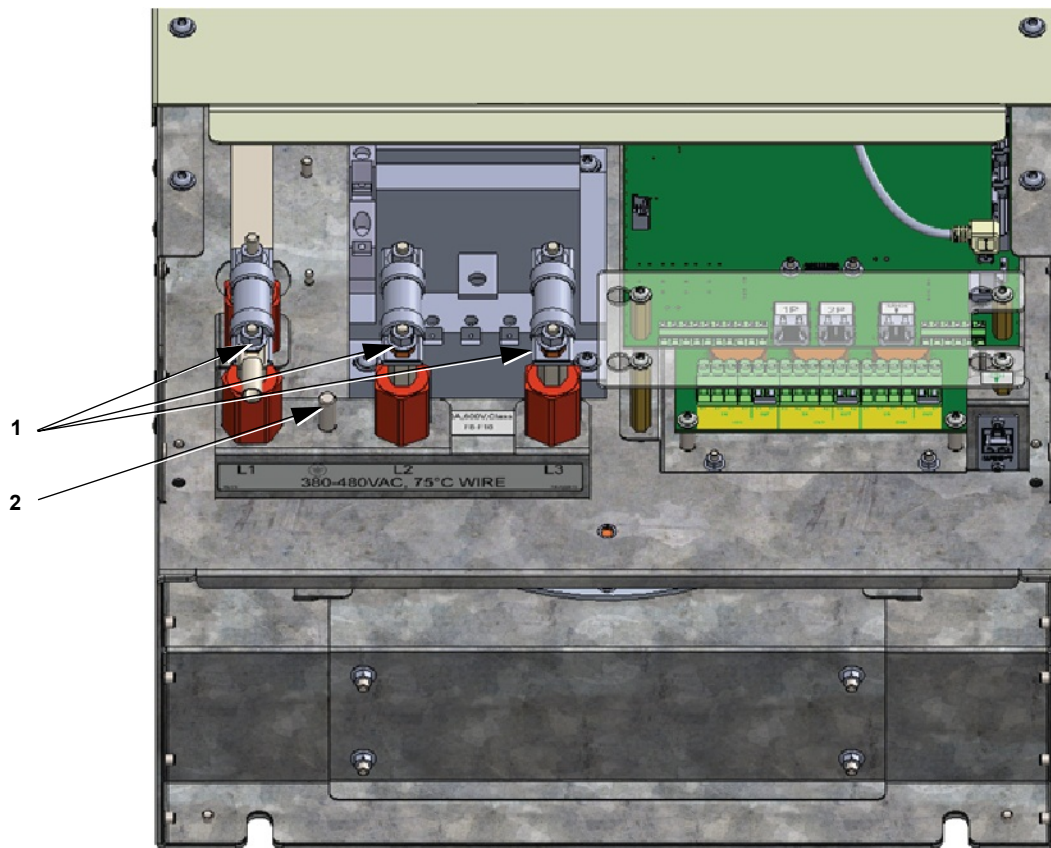

1. Power Terminals
2. Ground Bond

The power terminals are M6 studs. The ground terminal is an M8 stud.

Use either a crimp ring lug or box lug to make connections. Refer to the catalog for box lug part numbers.

1. Using a 10 mm socket, torque the power connections to 7.5 N•m (66.4 lb-in).
2. Using a 13 mm socket, torque the ground connection to 18.2 N•m (161.1 lb-in).

Power and ground nuts are provided in the chassis packaging.

120 A Models

120 A IP00 Customer Connections

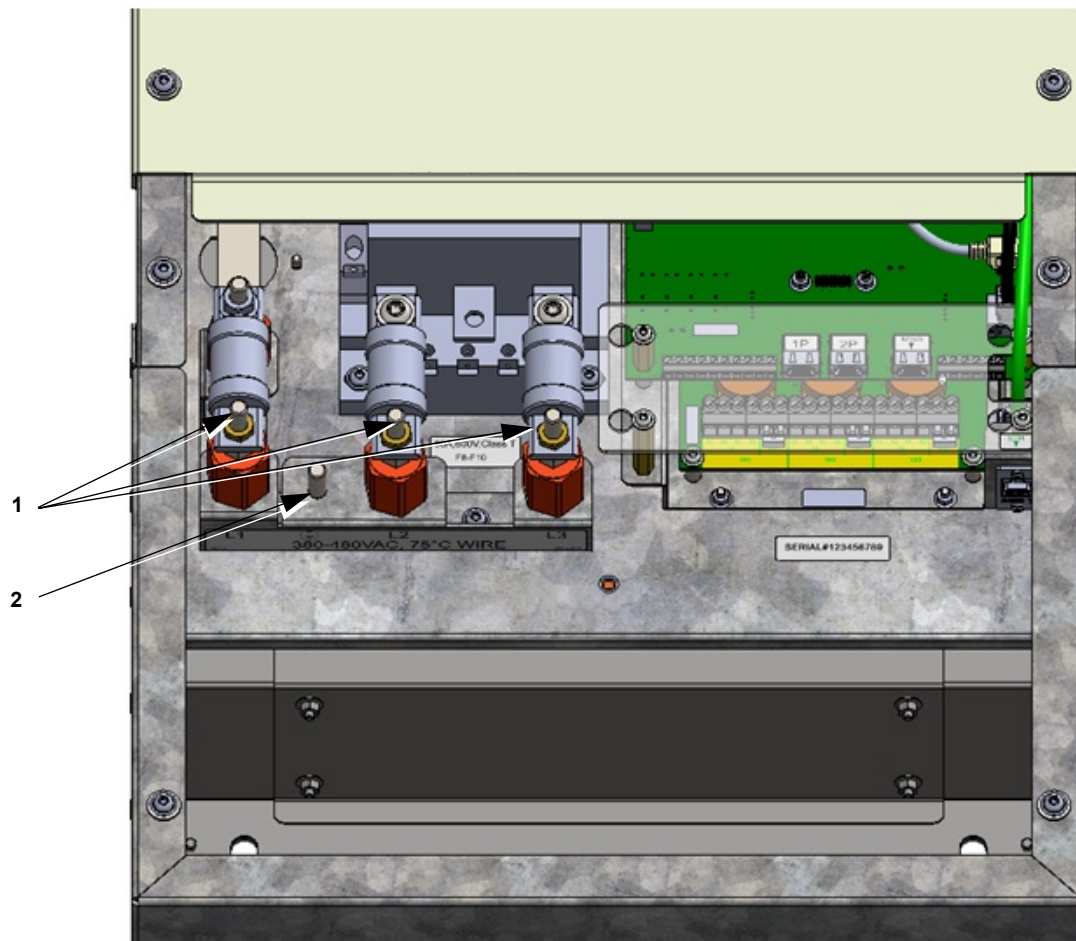

1. Power Terminals
2. Ground Bond

The power terminals and the ground terminal are M8 studs.

Use either a crimp ring lug or box lug to make connections. Refer to the catalog for box lug part numbers.

Using a 13 mm socket, torque all connections to 18.2 N•m (161.1 lb-in). Power and ground nuts are provided in the chassis packaging.

Access Cover Removal

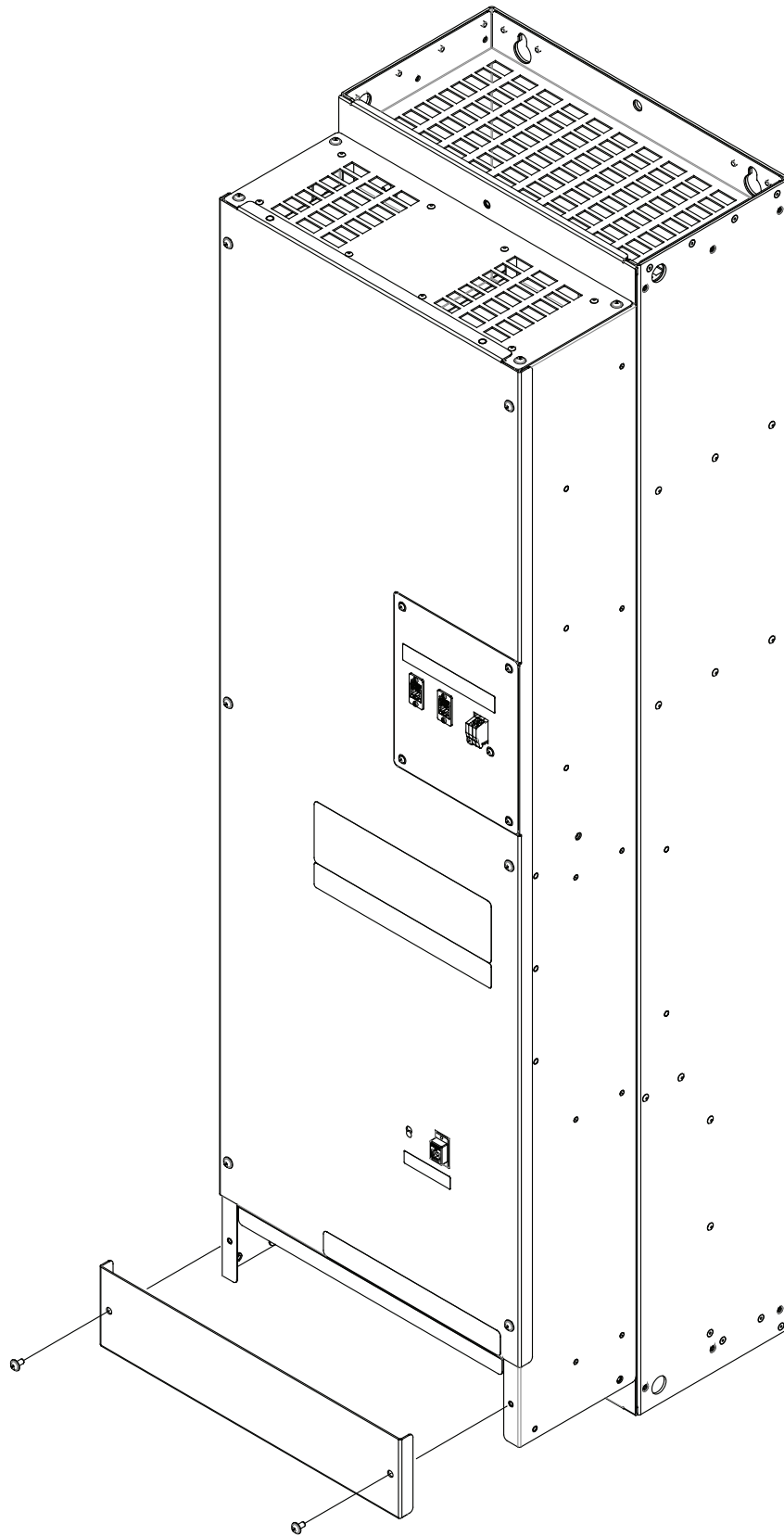

200 A and 300 A Models

200 A and 300 A Power and Ground Terminations

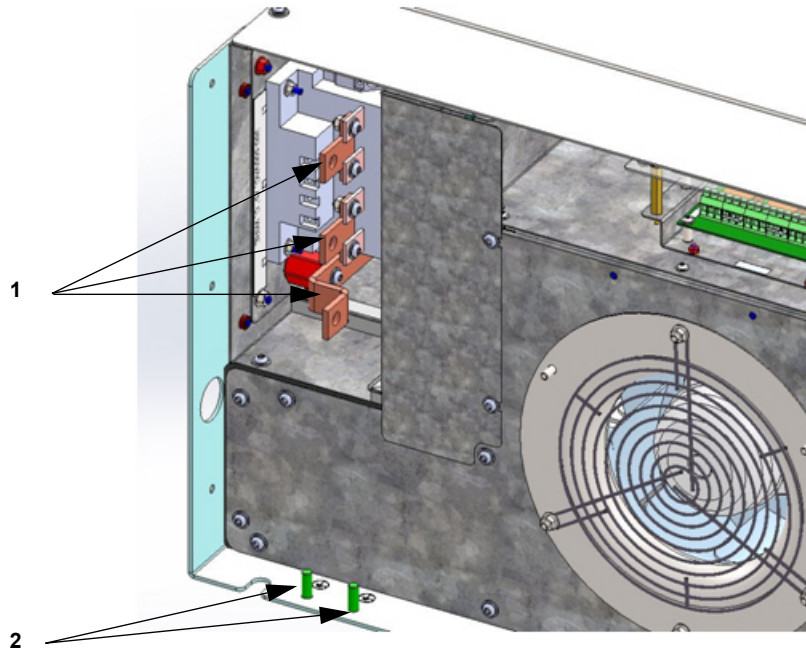

1. Power Termination
2. Ground Termination

The power terminals are provided with a 10 mm hole. The unit has three 40 mm long bolts, three nuts, and six washers included for power termination.

The ground terminal is an 8 mm stud. Two nuts are provided for the ground termination.

NOTE: Two ground terminals are provided if local codes require additional grounding. Otherwise, one ground connection is sufficient.

1. Using a 17 mm socket or combination wrench, torque the power connections to 36.5 N•m (323.1 lb-in).
2. Using a 13 mm socket, torque the ground connection to 18.2 N•m (161.1 lb-in).

Current Transformers (CTs)

⚠ DANGER

HAZARD OF ELECTRIC SHOCK, EXPLOSION, OR ARC FLASH

- Never open circuit a current transformer (CT).
- Always use grounded external CTs for current inputs.

Failure to follow these instructions will result in death or serious injury.

Ensure that CT secondary current is not present when wiring the CT secondary connections. The shorting jumpers must be installed at the X1 to X2 OUT of each CT channel on the CT board unless you are connecting an additional Master parallel unit. Refer to “Source Side CT Position Diagram” on page 44

General CT Information

The CT must be orientated properly during installation. The orientation is specified in the drawings with an arrow indicating the direction or polarity of the CT. Most CT manufacturers will indicate orientation with a label indicating H1 on one side of the CT or a dot. There can also be a label indicating H2 and/or an arrow on the CT. The H1 side of the CT should always be closest to the power source. If the CT has an orientation arrow, it should point from the source towards the load. See the installation instructions for the specific CTs being installed.

A shorting terminal block or shorting switch with galvanic isolation to the active filter for the CT secondary is required. Insert an interposing terminal block in a separate enclosure with the ability to short the secondary wiring of the CT. This provides the ability to short the CT without entering the active filter enclosure (which otherwise would require a power shutdown). Shorting terminal blocks are available in the catalog.

CT location is defined in relationship to the active filter system. CT location on the “Source Side” indicates that the CTs are physically located upstream of the active filter. The CTs will measure the improvement to the current as a result of the active filter operating. A CT location on the “Load Side” indicates that the CTs are downstream of the active filter. The CTs will monitor the Load current provided by both the source and active filter currents.

Two CTs are required to be installed, one on L1 phase and one on L2 phase of the conductors powering the loads to be compensated by the active filter system. If there are any line-to-neutral connected loads downstream of the active filter system's main CTs, a third CT is required on L3 phase.

NOTICE

MEASUREMENT ERRORS

CTs must be physically separated from any perpendicular conductor by at least 25 mm (1 inch) for every 1000 A of current flowing through the perpendicular conductor.

Failure to follow this instruction can result in a reduction in performance of the active filter.

If this practice is not followed, the magnetic field produced by the current flowing on the perpendicular conductor will cause CT measurement errors.

Minimum CT Requirements

The active filter uses a minimum of two external current transformers (CTs) to measure load current waveforms. Standard CTs rated for 50/60 Hz or 400 Hz with Type 1 accuracy rating, with a 5 A or 1 A secondary are acceptable. The largest primary rating for the CT is 10,000 A. Any splicing to the CT leads needs to be done with crimp style connectors or soldered.

The CT should be mounted on phases L1 and L2 with the orientation arrow pointing toward the load. Systems that are using two CTs can have the CTs installed on L1 and L3 or L2 and L3 if necessary. If L1 and L3 or, L2 and L3 CT configurations are used, this information must be provided to the qualified person commissioning the unit. Three external CTs are required if line-to-neutral connected loads are present.

NOTICE

REDUCED PERFORMANCE

CT wiring must be routed separately from power cables.

Failure to follow this instruction can result in a reduction in performance.

CT wiring must be routed directly from the conduit entry-plate to the terminal block of the CT board.

CT must be selected for:

- 5 A or 1 A secondary
- 250 to 10,000 primary rating
- 50/60 Hz or 400 Hz Rated
- Type 1 accuracy
- The CT primary current rating must exceed the maximum load current where they are installed;
- The maximum burden (in VA) on the CT is formed by the CT wiring and total active filter burden. This is equal to 1.0 VA for CTs with a 5 A secondary rating or 0.04 VA for CTs with a 1 A secondary rating.
- Wire size of the CT should be 4mm² (12 AWG) or 6mm² (10 AWG). Consult the CT manufacturer for secondary wiring recommendations. See “5 A Secondary Maximum Wire Length” and “1 A Secondary Maximum Wire Length” on page 43 for adding wire to CT secondary wiring.

CT secondary wiring must be either twisted and/or shielded pairs

Do not connect the active filter CT to any other loads. Use a separate current transformer if additional uses are required.

Any splicing to the CT leads needs to be done with crimp style connectors or soldered.

X2 of each CT installed must be grounded as close to the CT as possible.

A single active filter, not operating in parallel, can have the CTs installed either on the source side or load side of the active filter. Parallel systems must have the main CTs installed on the source side of the active filter system.

CT to CT Board Connection

The CT connection is made behind the small customer access panel at the bottom of the active filter chassis. See “Access Cover Removal” on page 37. Remove the customer access panel. The CT board is located behind and slightly below the control board. This is the location where the active filter CT secondary wiring must be terminated. Remove the clear plastic safety cover to access the CT board.

Typically, L1 CT will be connected to CH1 IN. There are two X1 and X2 IN terminals. The second set of IN terminals can be used to connect additional CTs that may be required for site specific conditions. X1 and X2 OUT are used for parallel active filter systems.

The terminal block on the CT board can accept wire sizes of up to 6 mm² (10 AWG) wire and has a torque specification of 1 N•m (9 lb-in).

NOTICE

CIRCULATING CURRENTS

When using shielded CT secondary wire, only ground the shield at one end of the cable.

Failure to follow this instruction can result in a reduction in performance.

NOTICE

INACCURATE FILTER OPERATION

Do not allow the conductor on which the CT is mounted to become lodged in the joint area of a split-core CT.

Failure to follow this instruction can result in inaccurate filter operation.

Control Board and CT Board Detail

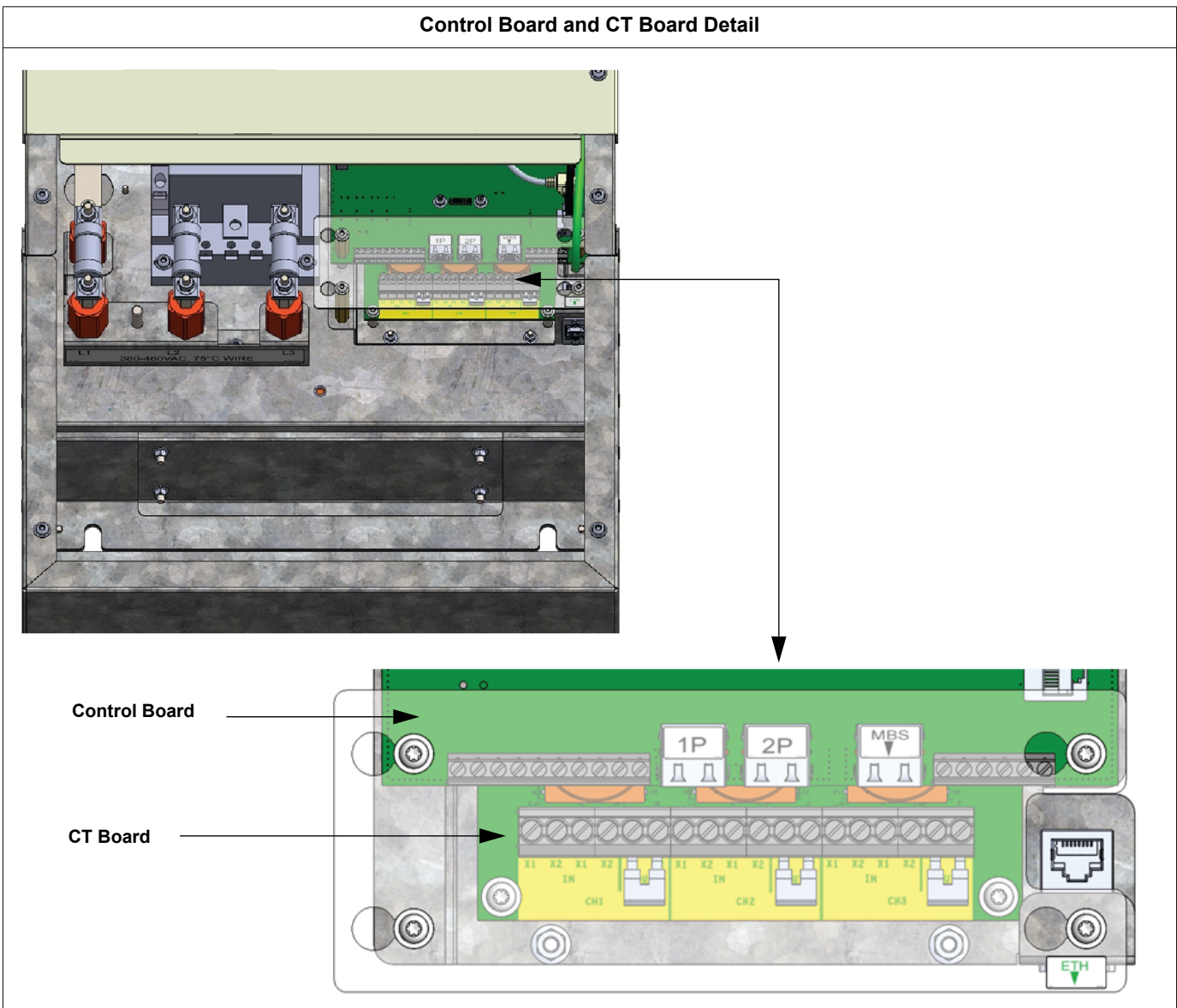

5 A Secondary Maximum Wire Length

CTs burden capacity with 5 A Secondary	Maximum wire length from active filter to CT in meters (feet)	
	4 mm ² (12 AWG)	6 mm ² (10 AWG)
5 VA	7 (24)	12 (41)
15 VA	38 (124)	63 (208)
25 VA	68 (224)	114 (375)
30 VA	83 (273)	139 (457)
35 VA	99 (324)	165 (541)
45 VA	129 (423)	216 (708)

1 A Secondary Maximum Wire Length

CTs burden capacity with 1 A Secondary	Maximum wire length from active filter to CT in meters (feet)	
	4 mm ² (12 AWG)	6 mm ² (10 AWG)
5 VA	373 (1223)	623 (2043)
15 VA	1135 (3724)	1895 (6215)
25 VA	1897 (6223)	3167 (10,387)
30 VA	2278 (7473)	3804 (12,477)
35 VA	2660 (7412)	4440 (14,563)
45 VA	3422 (11,224)	5712 (18,735)

Source Side CT Position Diagram
(CT's installed on the "Source Side" or upstream of the active filter)

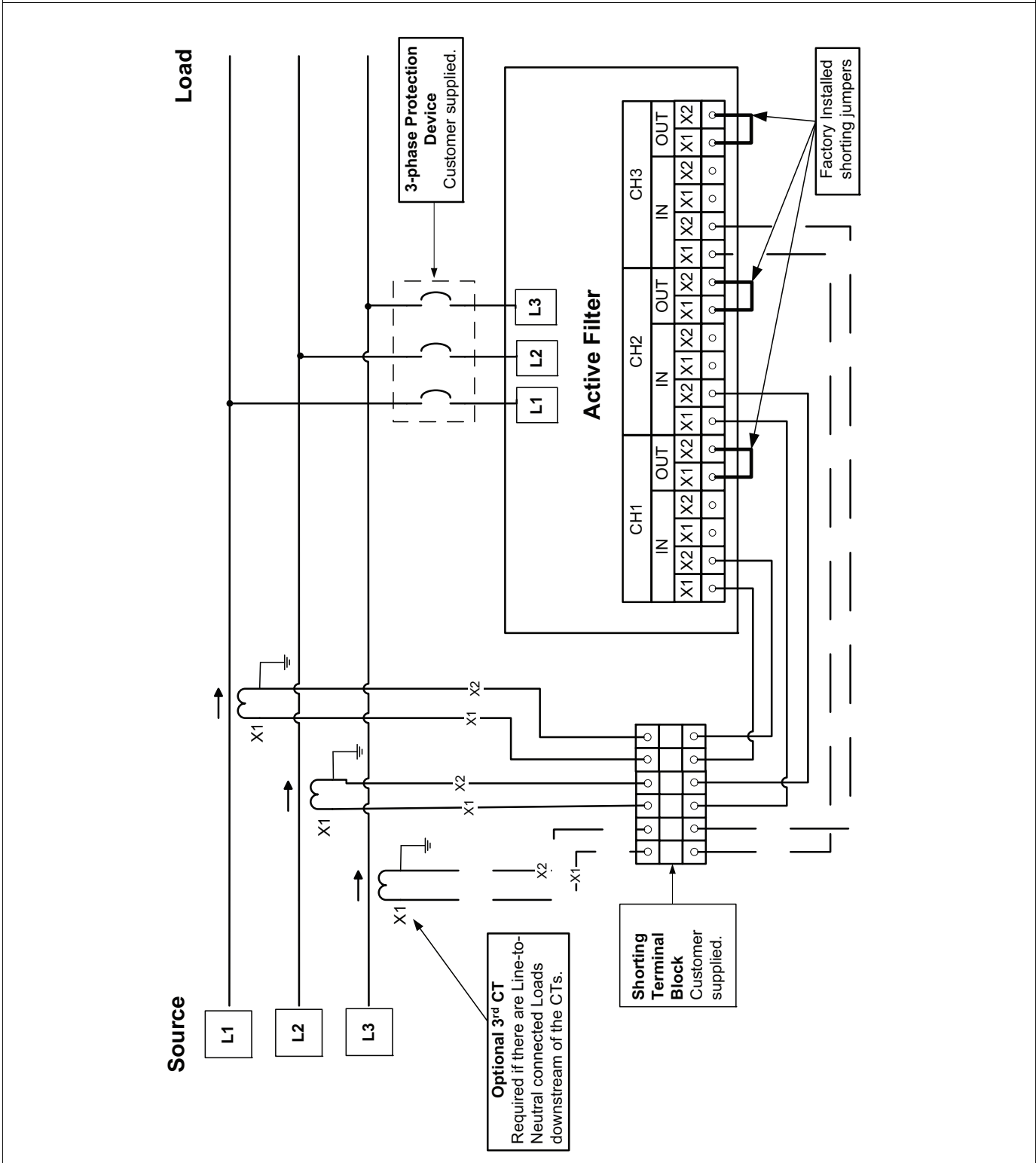

NOTE: The factory installed shorting jumpers must be installed.

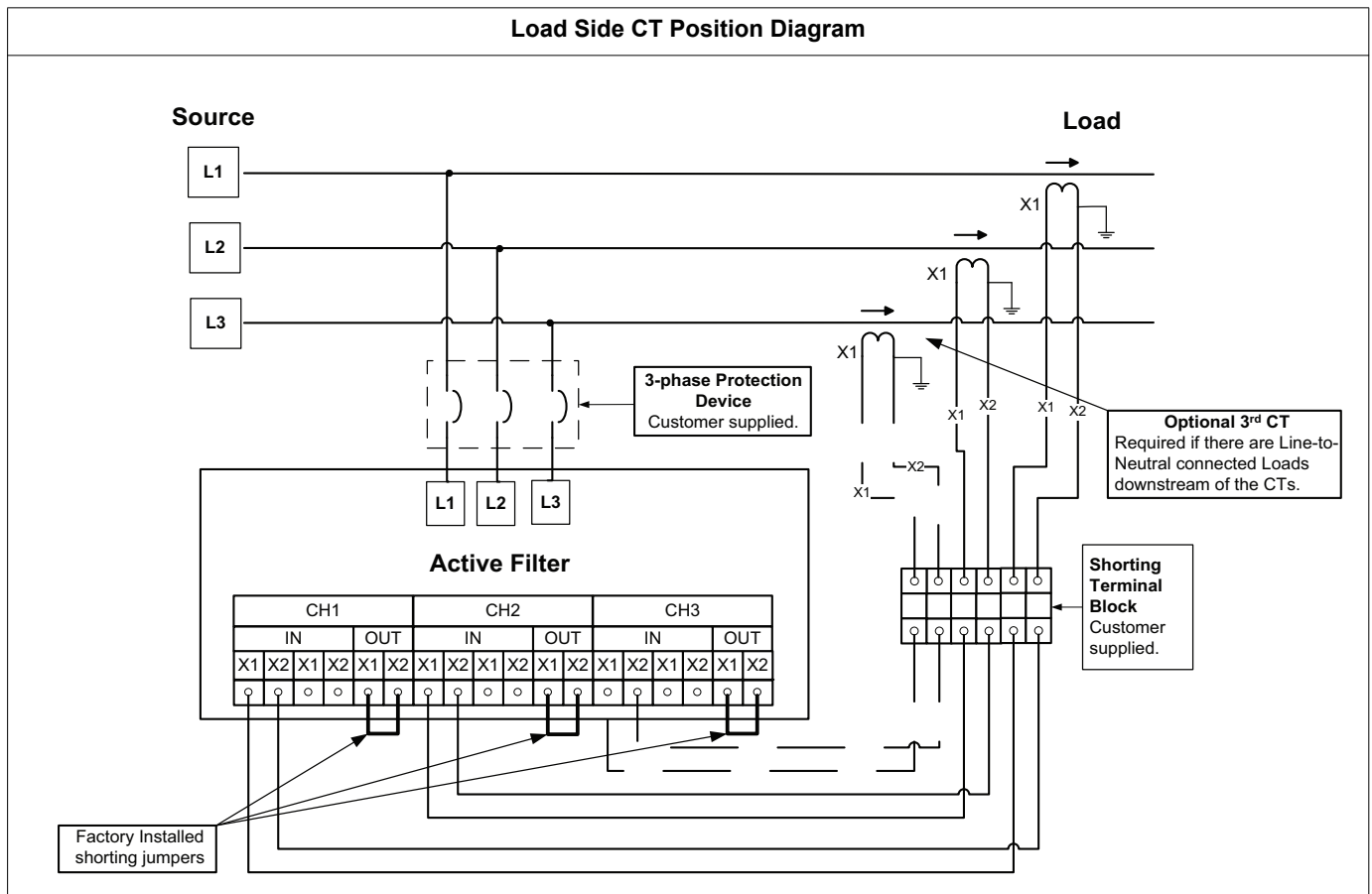

NOTE: The factory installed shorting jumpers must be installed.

Parallel System

Up to ten active filters can be installed in parallel. If more than ten units in parallel are required, contact the local sales representative for assistance prior to installation.

CT Installation Parallel Units

⚠ DANGER

HAZARD OF ELECTRIC SHOCK, EXPLOSION, OR ARC FLASH

The factory provided shorting jumpers must be installed at the OUT of the CT board of the last unit with CT secondary wiring connected.

Failure to follow these instructions will result in death or serious injury.

The active filters can be set up to be either Master or Slave. To be a candidate as a Master, the unit must be provided with CT secondary wiring to the CT board. See “Control Board and CT Board Detail” on page 53. There is no limit to the number of units that can be set up as a Master candidate. At least two units should be capable of being the Master in any parallel installation.

The main CTs must be installed on the source side of the active filter system. Examples of CT secondary wiring can be seen on the following pages in this section. Refer to “Over-current Protection Device Selection” on page 33 for information on circuit breaker and fuses required.

Source Side CT Position Parallel Units Diagram

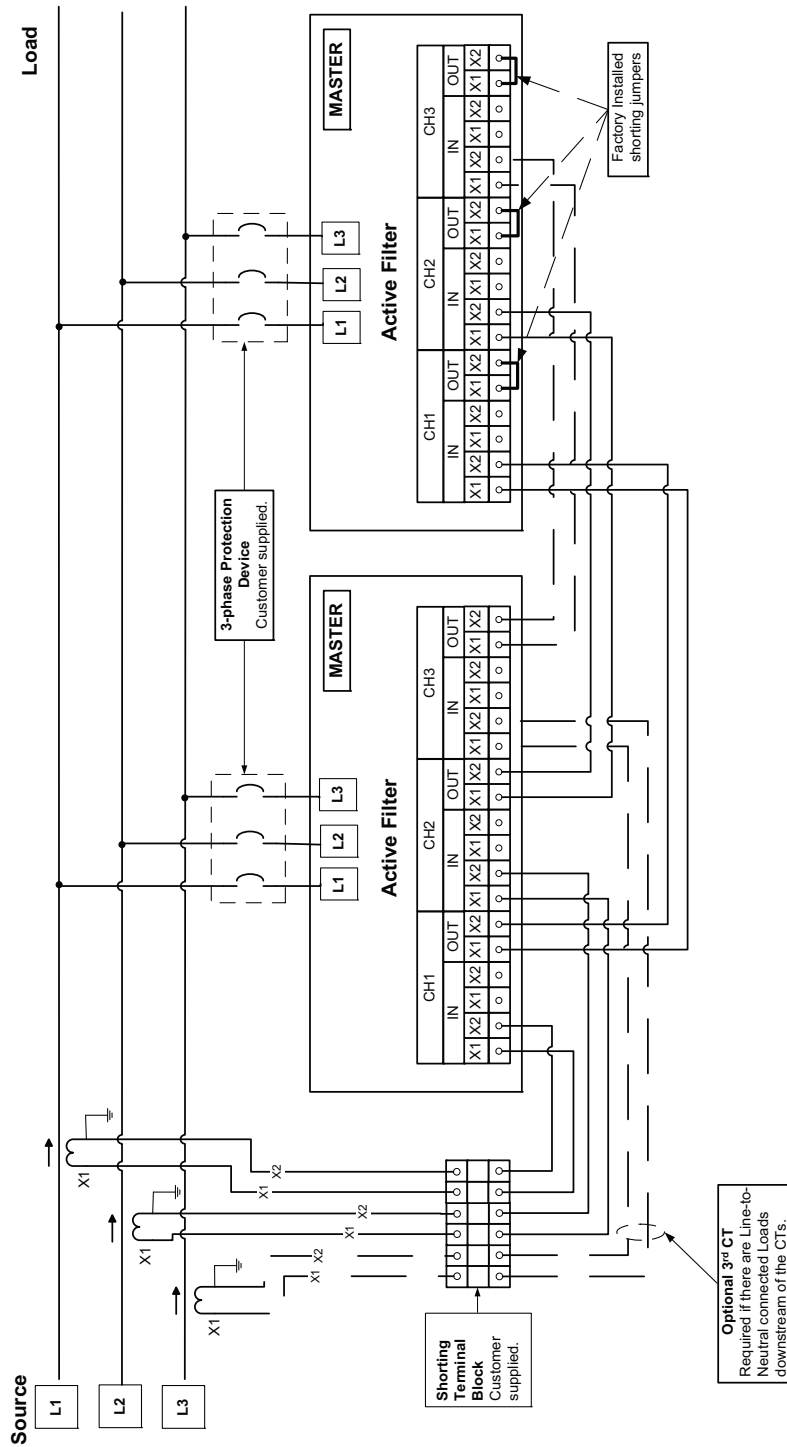

CT Wiring for 3 Masters

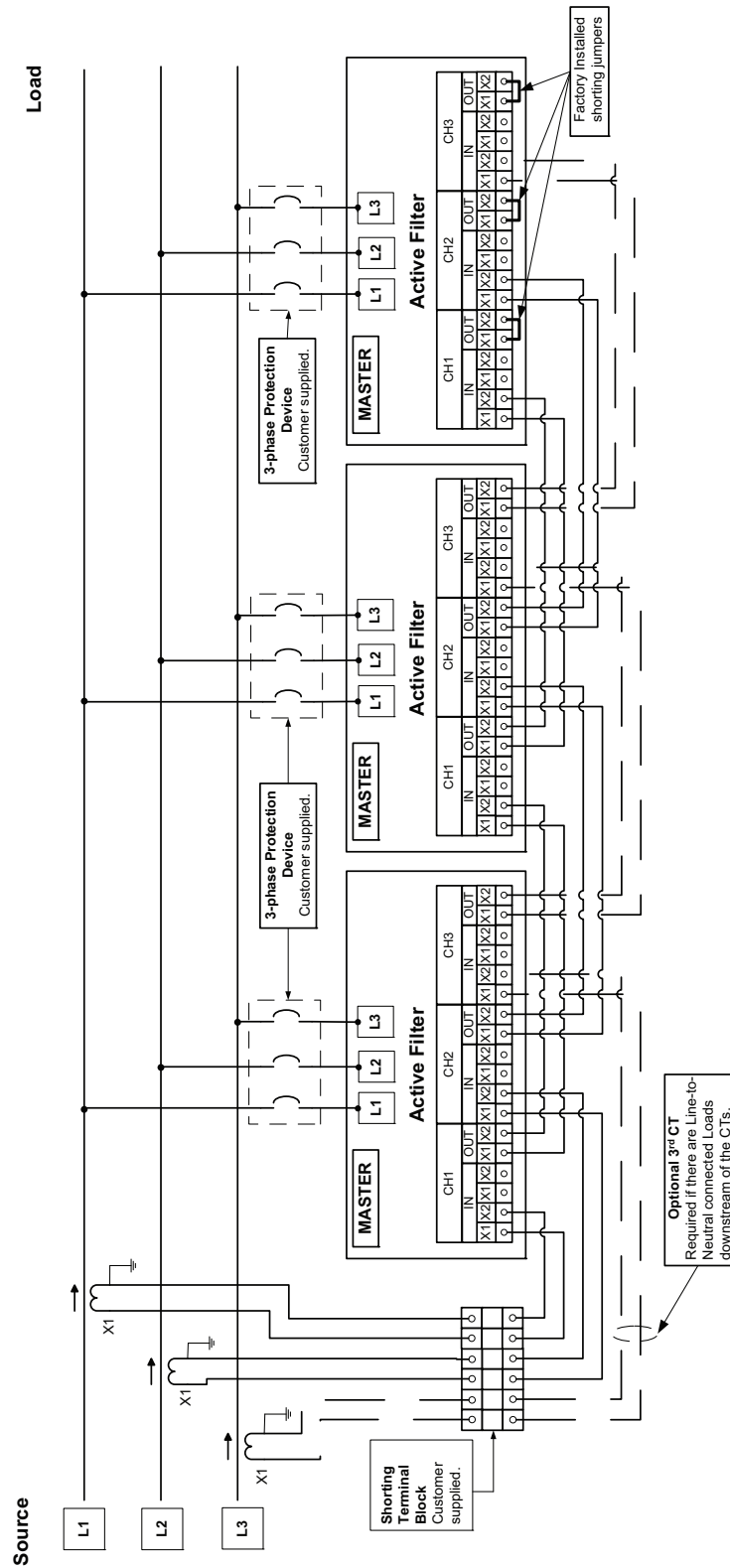

CT wiring for 2 Masters and 1 Slave

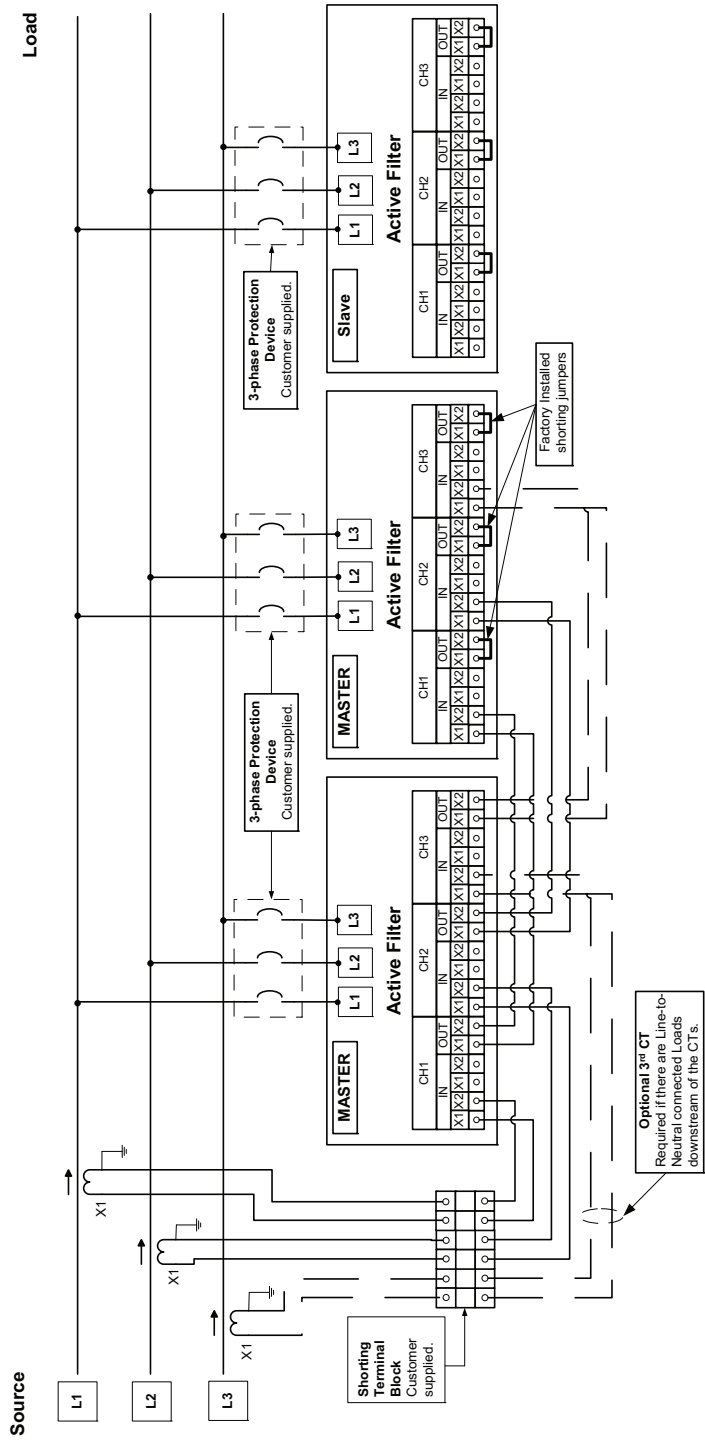

CT wiring for 2 Masters and 3 Slaves

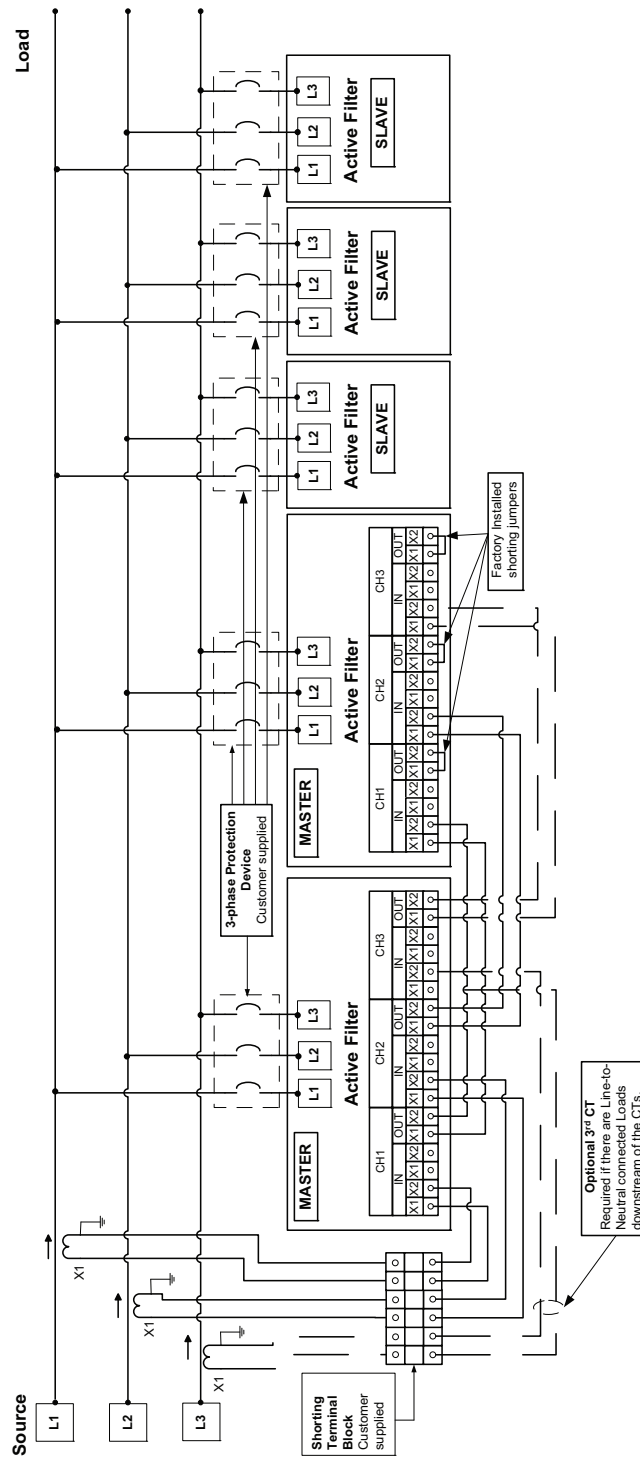

Parallel Communication

For parallel operation, the units communicate through the RJ-45 connectors labeled 1P and 2P on the Control Board. This is a unique communication protocol that is only to be used for parallel communication. The 2P jack has an RJ-45 termination plug installed at the factory.

NOTICE

EXCESSIVE NOISE IN THE COMMUNICATION CIRCUIT

When the unit is set to operate in parallel mode, the termination plug must be installed in any RJ-45 jacks that are not used for parallel communication wiring. See the wiring diagrams in this section.

Failure to follow this instruction can result in communication errors.

CAT5e cable with all 8 conductors terminated at the RJ-45 connections is required for parallel communication. It is recommended that shielded Cat5e cable be used. Ensure that the total cable length does not exceed 76 meters (250 feet). The CAT5e cable with RJ-45 plugs can be purchased as an option. Refer to the catalog for optional paralleling cable part numbers.

Control Board and CT Board Detail

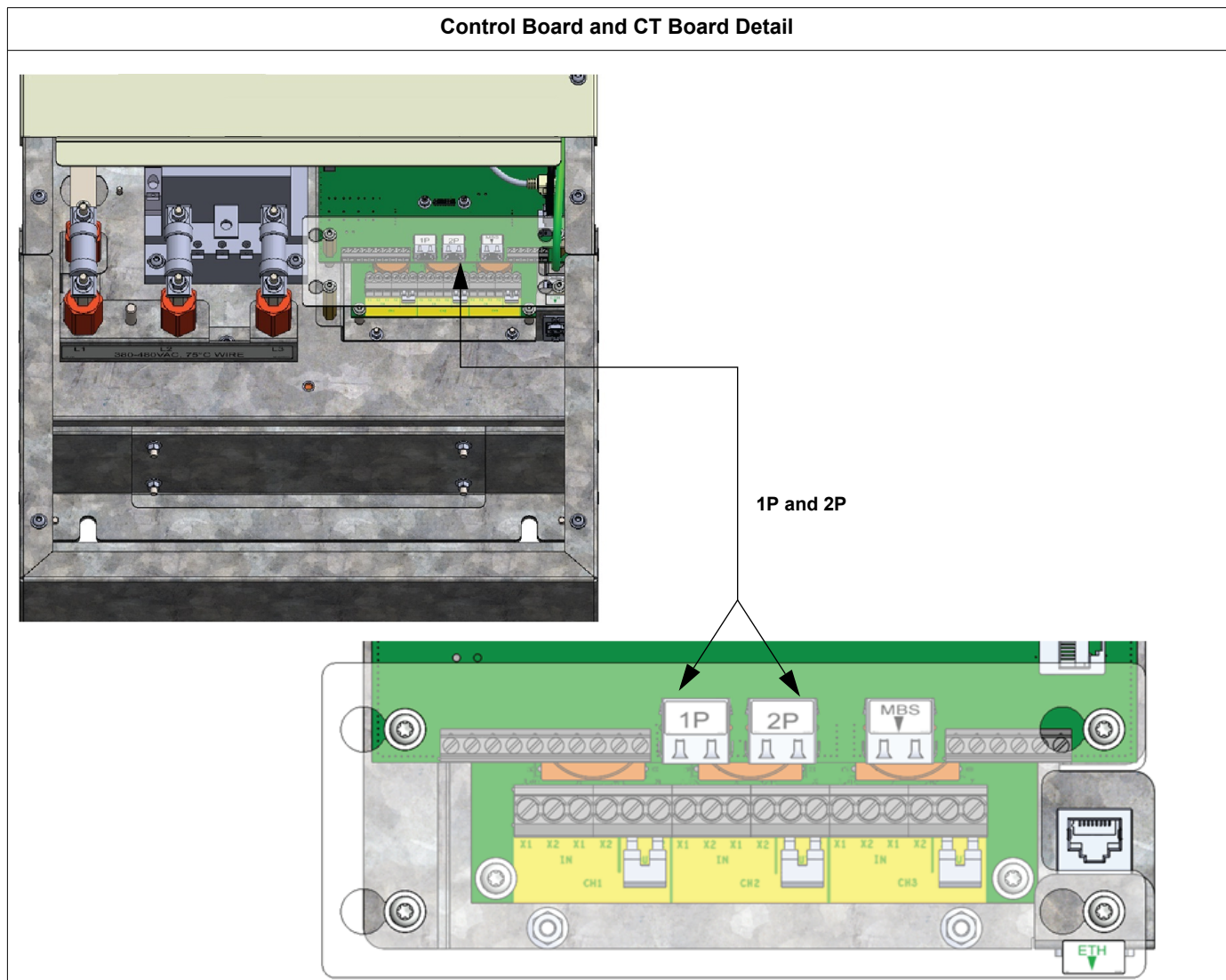

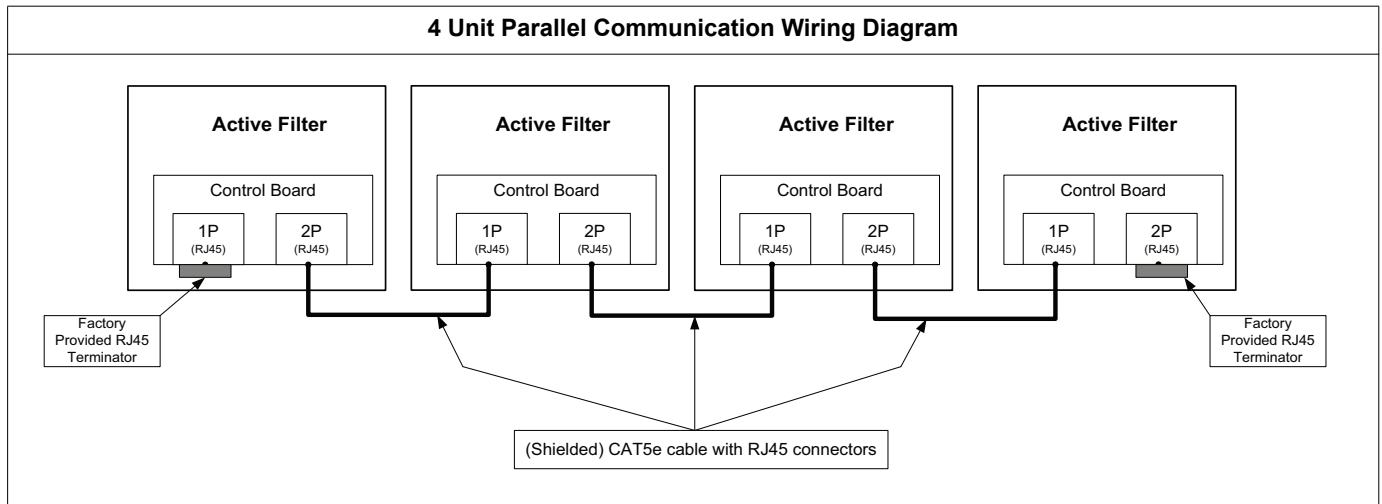
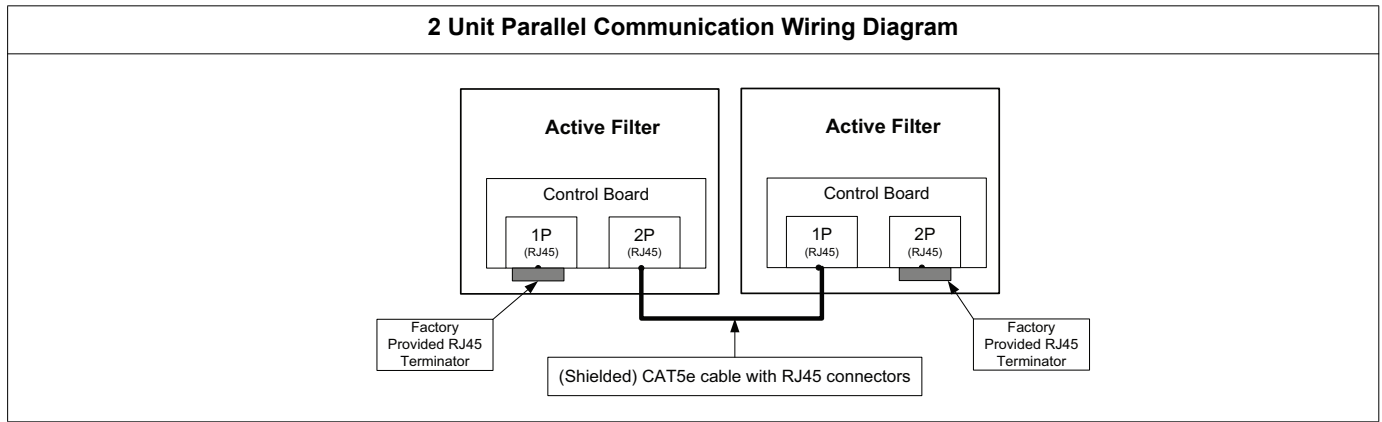

Control Wiring

Dry Contact output

Four dry Contact outputs are available at J2 of the Control Board. See “Control Board and CT Board Detail” on page 53. One common and four switchable outputs are available labeled Q1 to Q4. The four outputs can be programmed to change states on different conditions by the HMI and be set to either normally open or normally closed. See the User Manual for setting the output contacts. Maximum voltage accepted is 250 V AC or 30 V DC with a 1 A maximum current.

Digital Input Control

Four input controls are available at J2 of the Control Board. See “Control Board and CT Board Detail” on page 53. One Ground and four inputs labeled I1 to I4. The inputs are at 5 V DC and are grounded to activate. The control function can be programmed by the HMI. See the User Manual for setting the functionality of the input control.

Modbus TCP/IP

Modbus TCP/IP monitoring is available at the RJ-45 jack to the right of the Control Board labeled ETH. Refer to “Control Board and CT Board Detail” on page 53. Modbus addresses are provided in the User Manual.

Modbus Serial

A serial Modbus connection is available through an RJ-45 jack labeled MBS on the control board. Refer to “Control Board and CT Board Detail” on page 53. Modbus addresses are provided in the User Manual.

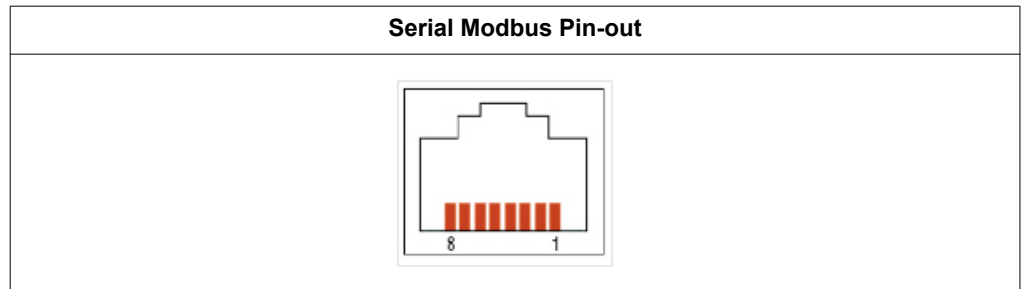

Pin	Signal Name	Direction	Meaning
1	Not connected	-	
2	Not connected	-	
3	Not connected	-	
4	D1	Input/Output	Transfer data (RS-485)
5	D0	Input/Output	Transfer data (RS-485)
6	Not connected	-	
7	Not connected	-	
8	SG	-	Signal ground

Control Board and CT Board Detail

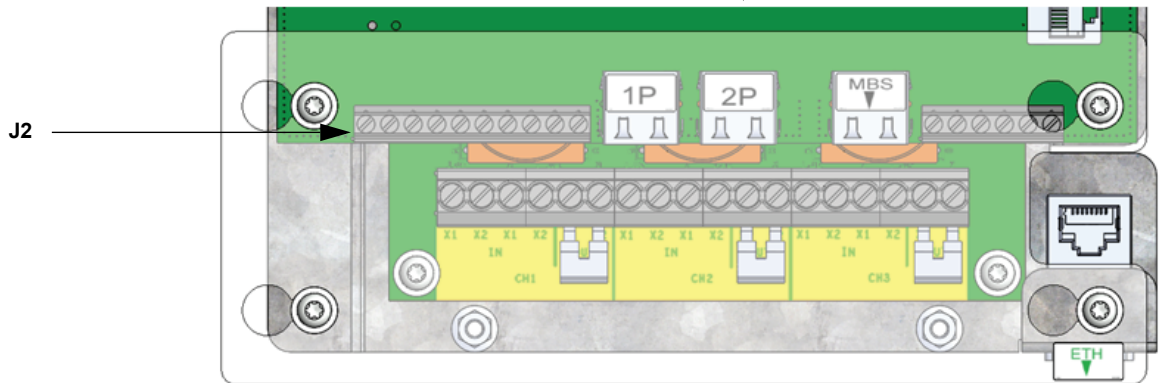
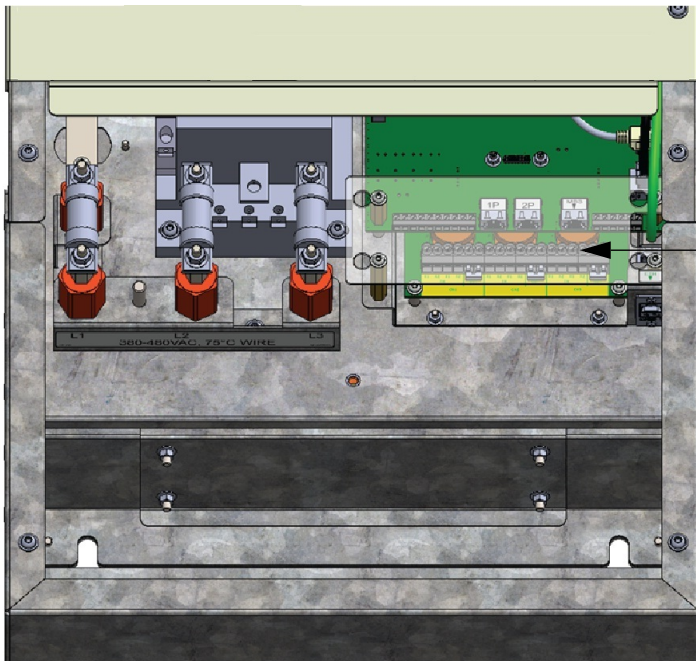

Control Board J2 Detail

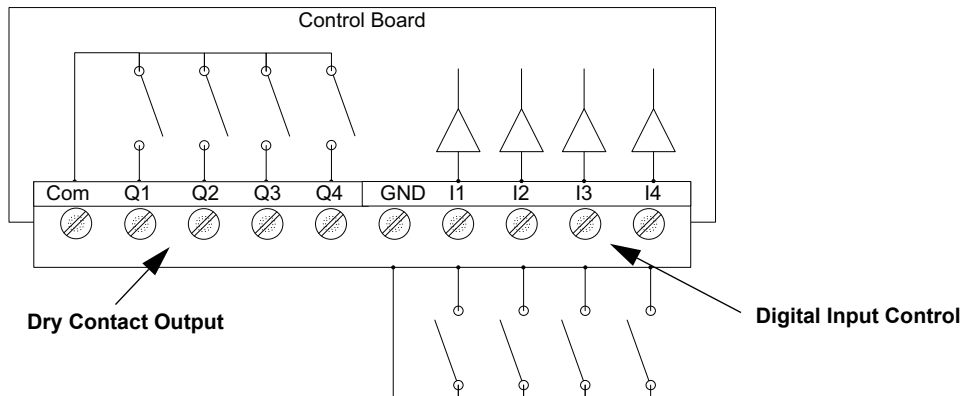

Chapter 5 UL Type 1/IP20 Conversion Kit Assembly (Optional)

This chapter provides information for the UL Type 1/IP20 Conversion Kit Assembly. This kit is available as an option for converting an IP00 unit to an IP20.

DANGER

HAZARD OF ELECTRIC SHOCK, EXPLOSION, OR ARC FLASH

- Apply appropriate personal protective equipment (PPE) and follow safe electrical work practices. See NFPA 70E in the USA, CSA Z462, or applicable local standards.
- This equipment must be installed and serviced only by qualified electrical personnel.
- Do not exceed the device's ratings for maximum limits.
- Ground equipment using the ground connecting point provided before turning on any power supplying this device.
- Turn off all power supplying this device and the equipment in which it is installed before working on the device or equipment.
- After removing power, wait for 15 minutes to allow the capacitors to discharge prior to opening the doors or removing covers.
- Always use a properly rated voltage sensing device to confirm power is off.
- Replace all devices, doors, and covers before turning on power to this equipment.
- Carefully inspect the interior for tools left behind before closing and sealing the door.

Failure to follow these instructions will result in death or serious injury.

NOTICE

RISK OF CONTAMINATION BY CONDUCTIVE MATERIAL OR DEBRIS

Thoroughly remove any metal shavings from the unit after any drilling for cable entry access.

Failure to follow this instruction can result in equipment damage.

Any drilling on the wall mount kit should be performed either before attaching it to the chassis or after the chassis and wall mount kit are mounted in the desired location. Ensure that all metal shavings inside of the wall mount kit are removed before energizing.

The active filter warranty is void if operational difficulties are found to be caused by metal particles from the installation process.

Prepare the active filter chassis for UL Type 1/IP20 Conversion Kit

1. Remove the access cover by removing the two T20 screws.
2. Retain the screws and discard the access cover.
3. Remove the four T20 screws holding the Remote HMI Connection Assembly.
4. Remove the Remote HMI Connection Assembly, being careful not to damage the wires connected at the back.

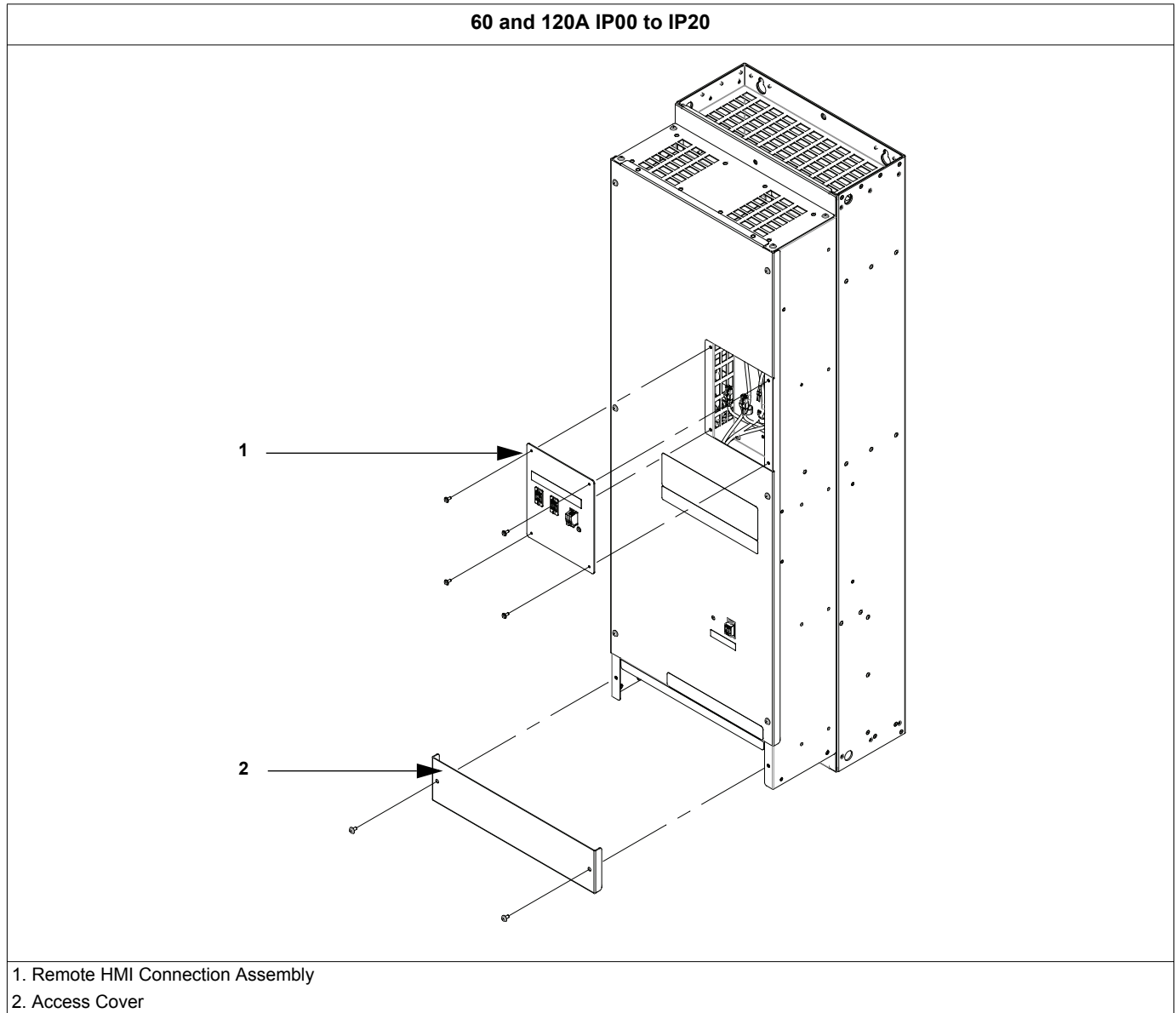

5. At the back of the plate, disconnect the two RJ-45 plugs. With a small flat-blade screwdriver, disconnect the red and black power wires.

Back of HMI Blank Plate with Connections

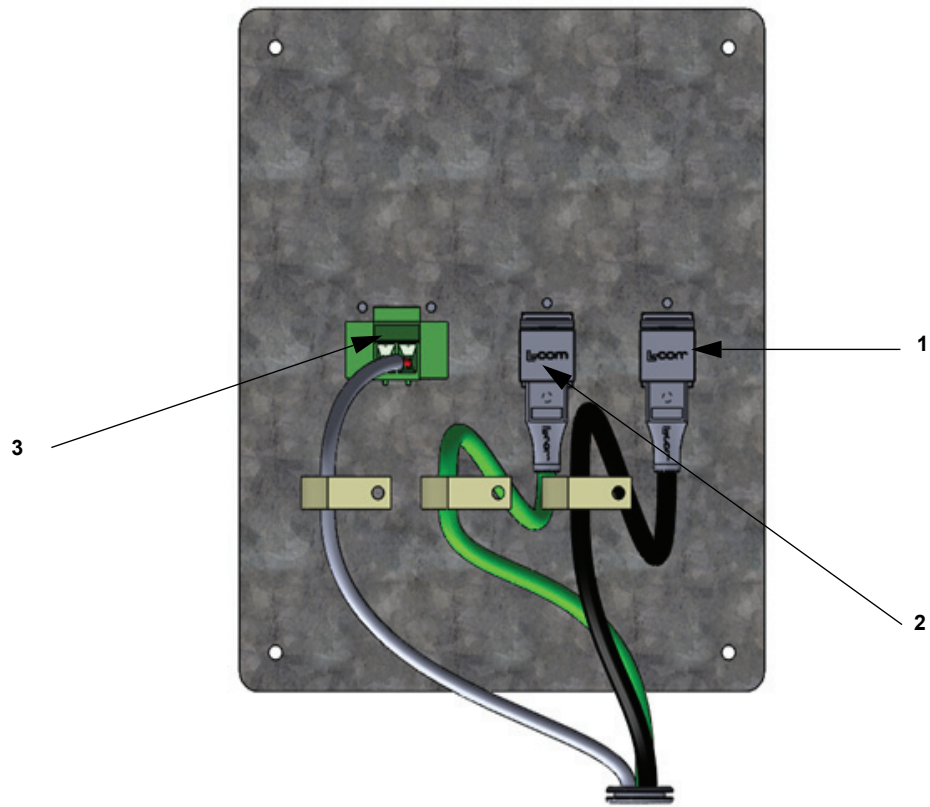

1. HMI COM
2. Ethernet
3. -/+ HMI Power

Connect the HMI ground wire to the chassis

1. Remove the green (ground) wire from the hardware bag.
2. Using the provided screw from the hardware bag, connect the ring lug end of the green ground wire to the HMI housing on the chassis.

Back of HMI Blank Plate with Connections

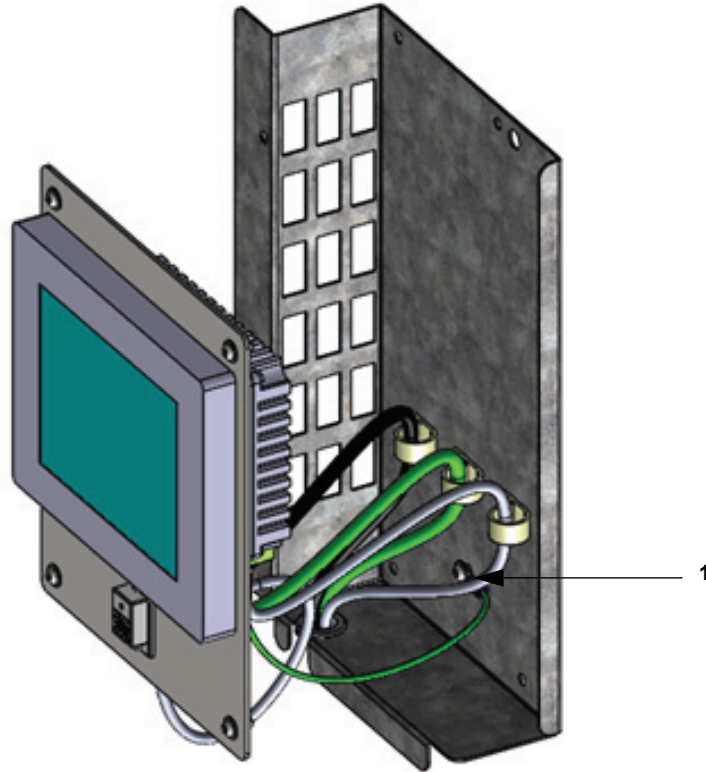

1. HMI Ground Wire Connection. Attach with the provided M4 T20 screw.

Attach the HMI to the HMI mounting plate

The HMI is provided in a box with the chassis. The mounting plate, USB cable, and hardware are provided in the UL Type 1/IP20 Conversion Kit.

1. Remove the Display module by pressing the yellow tab labeled Press to Open.
2. Unplug the HMI back module from the HMI Display module.
3. Remove the plastic nut from the back of the display module
4. Using firm pressure, insert the Tee into the hole provided on the back of the display module.
5. Attach the HMI display module to the HMI mounting plate
6. Re-install the plastic nut onto the display module.
7. Tighten the nut with the tool provided in the HMI box.
8. Plug the HMI back module onto the HMI display module.

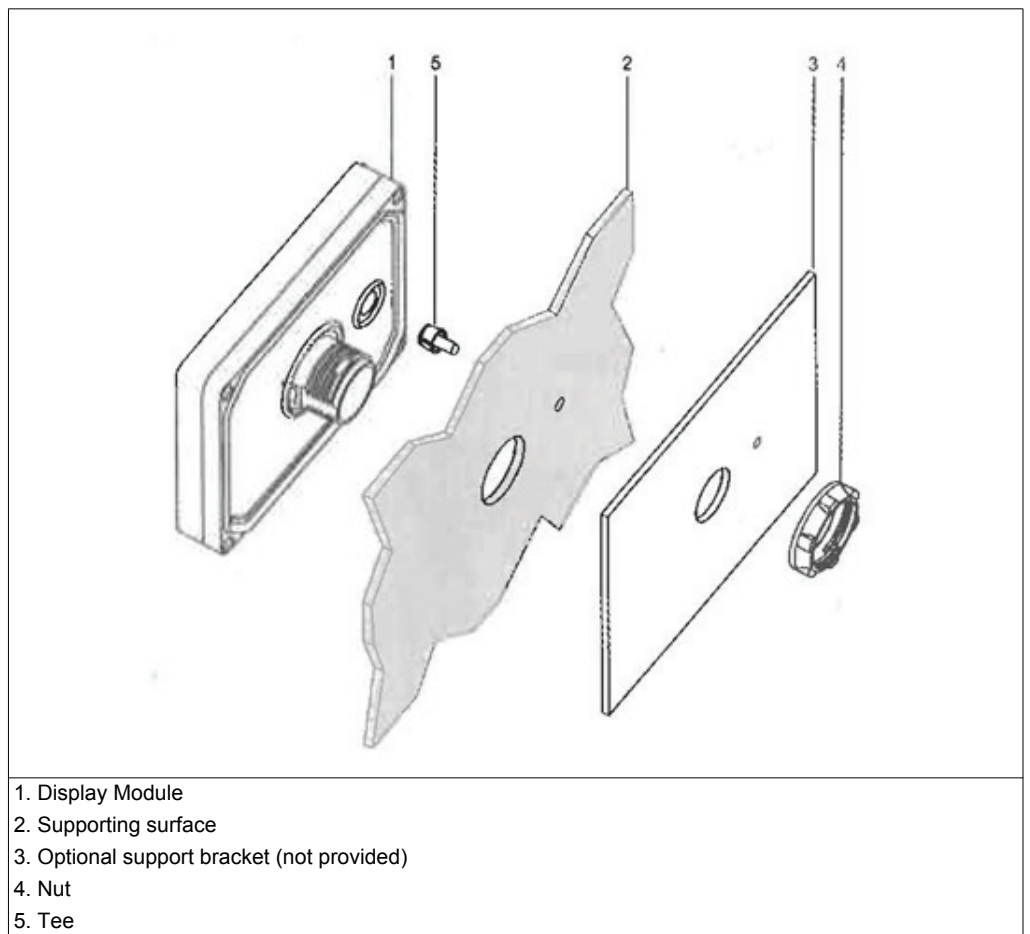

Connect the USB jack to the HMI mounting plate

1. Remove the USB jack and connector from the plastic bag provided in the IP20/UL Type 1 conversion kit.
2. Pass the USB connector through the hole provided through the front of the HMI mounting plate.
3. Connect the HMI jack to the mounting plate using the two T10 screws.
4. Plug the USB connector into the USB jack located at the bottom of the HMI.

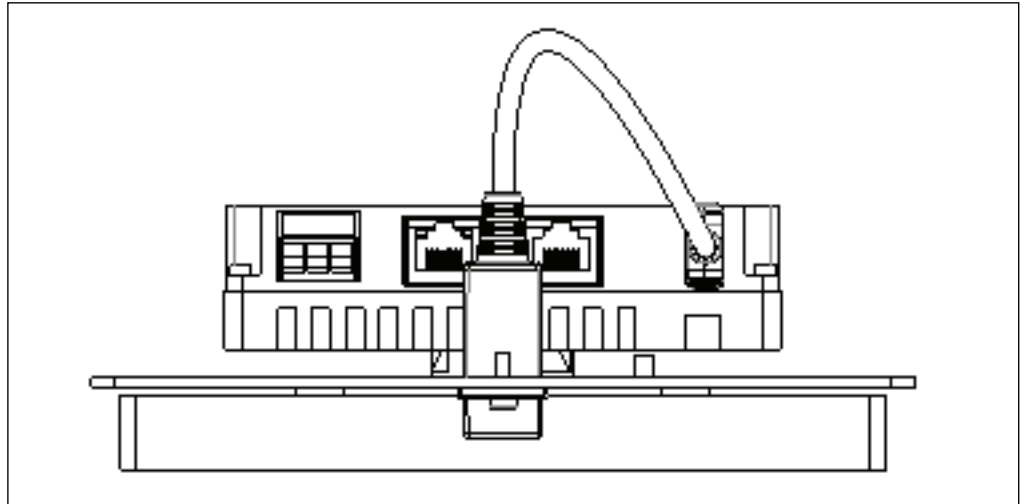

HMI Power wiring

1. Remove the terminal block from the HMI box.
2. Wire the chassis HMI power wiring to the HMI terminal block.
3. Connect the red power wire to the terminal labeled +.
4. Connect the black power wire to the terminal labeled -.
5. Connect the green ground wire to the terminal labeled with the ground symbol.

Installation of the HMI assembly in the Chassis

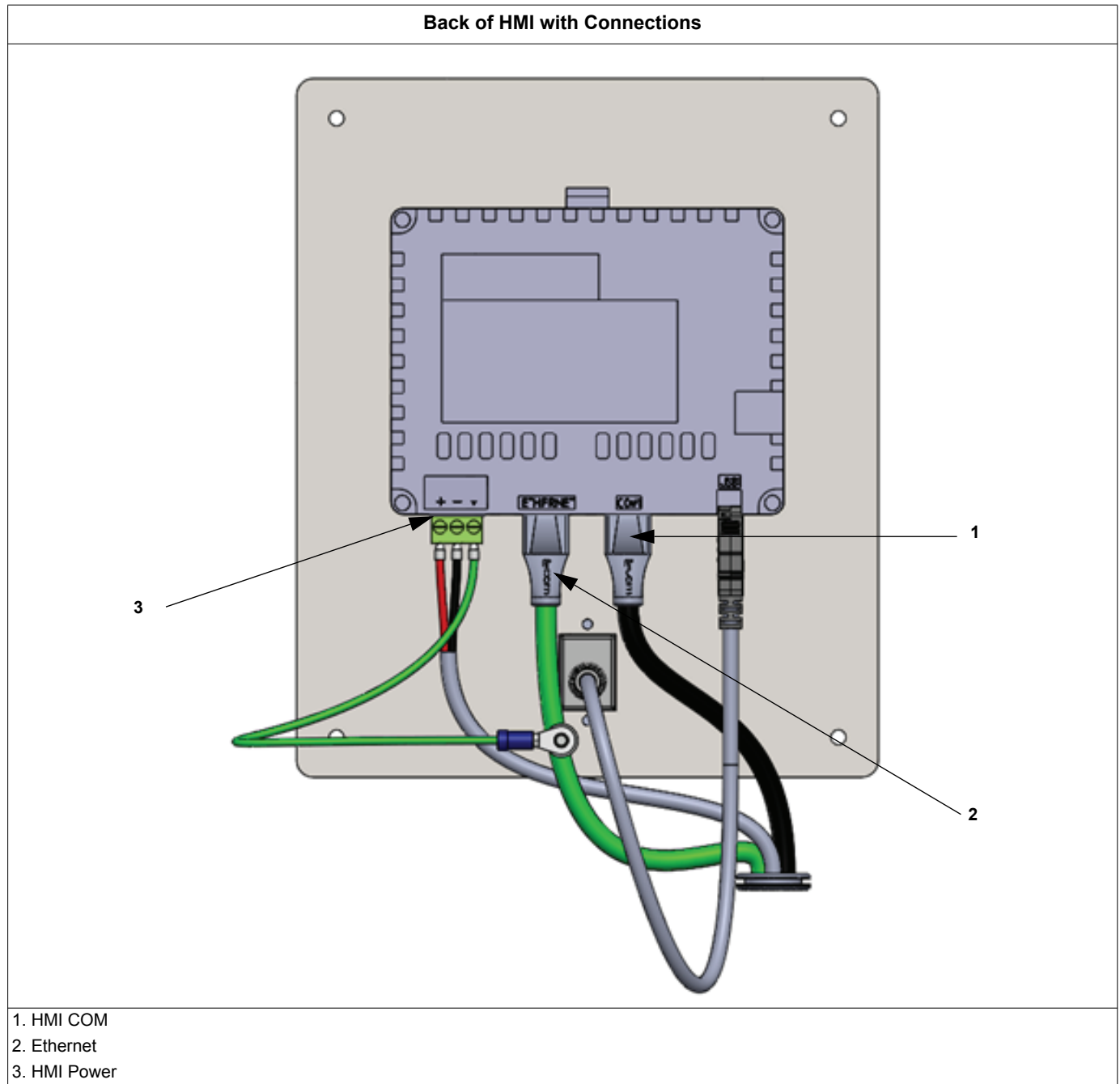

1. Connect the power terminal to the bottom of the HMI.
2. Connect the cable labeled ETHERNET to the ETHERNET jack of the HMI.
3. Connect the cable labeled COM to the COM1 jack of the HMI.
4. Using the four T20 screws, connect the HMI plate to the chassis. Torque to 1.7 N•m (15.05 lb-in).

Attaching the Wall Mount Kit to the Chassis for 60 A and 120 A Units

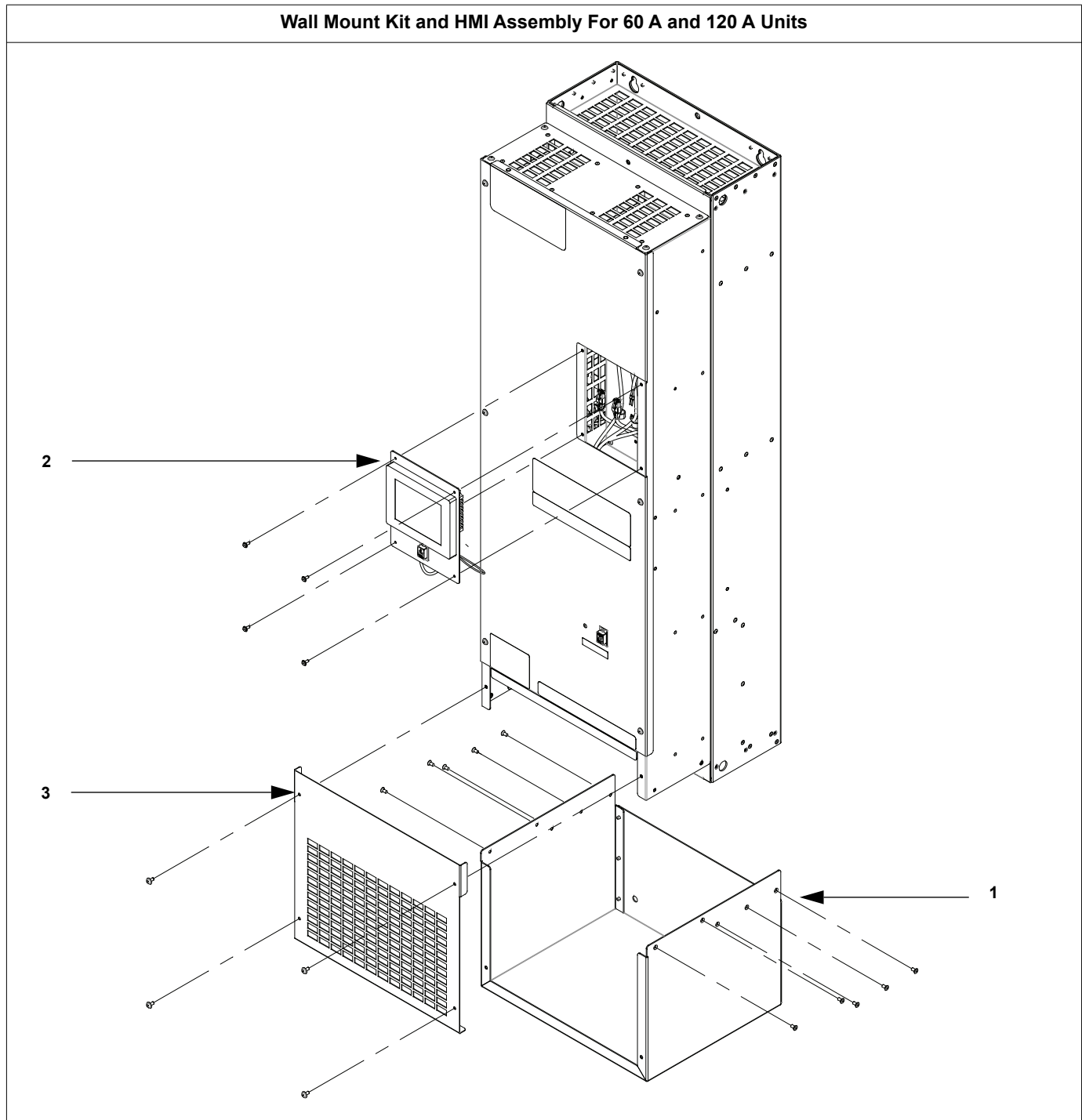

1. Fasten the Wall Mount Kit to the chassis with the provided T25 screws. Torque to 5.7 N•m (50.45 lb-in).
2. Fasten the HMI to the chassis with the provided T20 screws. Torque to 1.7 N•m (15.05 lb-in).
3. Fasten the Wall Mount Kit cover to the Wall Mount Kit with the provided T20 screws. Torque to 3.4 N•m (30.09 lb-in).

Attaching the Wall Mount Kit to the Chassis for 200 A and 300 A Units

Wall Mount Kit and HMI Assembly For 200 A and 300 A Units

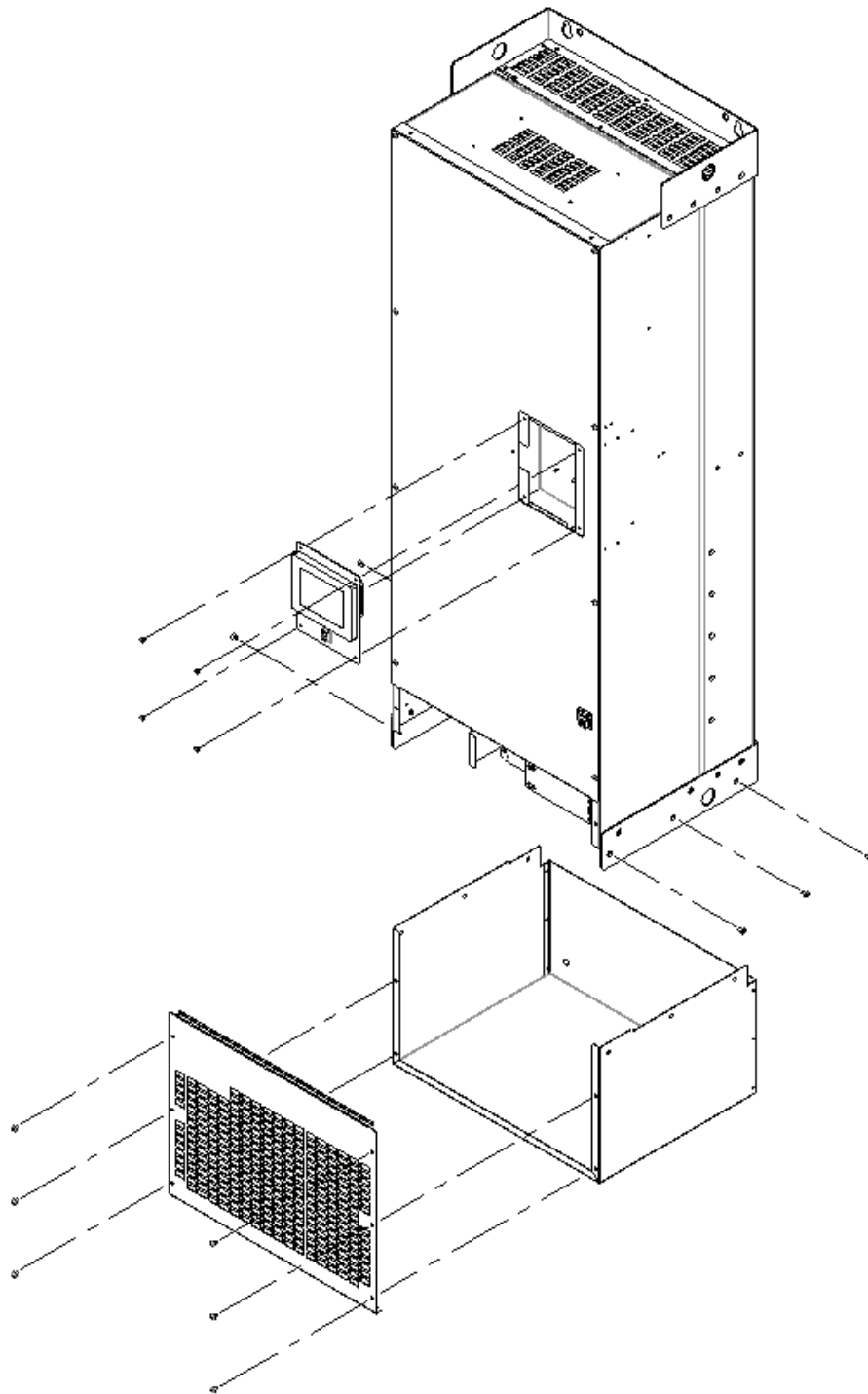

1. Fasten the Wall Mount Kit to the chassis with the provided T25 screws. Torque to 5.7 N•m (50.45 lb-in).
2. Fasten the HMI to the chassis with the provided T20 screws. Torque to 1.7 N•m (15.05 lb-in).
3. Fasten the Wall Mount Kit cover to the Wall Mount Kit with the provided T20 screws. Torque to 3.4 N•m (30.09 lb-in).

Chapter 6 Pre-commissioning

This chapter provides information for preparation of the active filter for commissioning. Before applying power, read and understand this information thoroughly.

Instruments required for commissioning

- Voltmeter or multimeter
- Clamp-on ammeter
- Megohmmeter

Pre-energizing procedure

DANGER

HAZARD OF ELECTRIC SHOCK, EXPLOSION, OR ARC FLASH

- Apply appropriate personal protective equipment (PPE) and follow safe electrical work practices. See NFPA 70E in the USA, CSA Z462, or applicable local standards.
- This equipment must be installed and serviced only by qualified electrical personnel.
- Do not exceed the device's ratings for maximum limits.
- Ground equipment using the ground connecting point provided before turning on any power supplying this device.
- Turn off all power supplying this device and the equipment in which it is installed before working on the device or equipment.
- After removing power, wait for 15 minutes to allow the capacitors to discharge prior to opening the doors or removing covers.
- Always use a properly rated voltage sensing device to confirm power is off.
- Replace all devices, doors, and covers before turning on power to this equipment.
- Carefully inspect the interior for tools left behind before closing and sealing the door.

Failure to follow these instructions will result in death or serious injury.

Installation Inspection

Inspect all connections for both power and control wiring. Ensure that the correct termination points have been made for each wire. Ensure that all connections are firmly tightened prior to start-up.

Pre-Commissioning Checklist

Prior to commissioning the active filter system, the following items must be completed:

- Electrical connections have been made in accordance with local codes.
- Main CTs are installed to measure the current of the system to be corrected.
- The secondary wiring of the main CTs have been connected to the CT board of the active filter.
- If it is a parallel active filter system, CT wiring and parallel communications wiring have been installed between the CT boards of each unit.
- All drives, harmonic generating loads, downstream of the main CTs must have the recommended minimum 3% line reactor or DC choke installed (required for optimum performance when harmonic mode is intended).
- There are no un-isolated capacitors, such as power factor correction capacitors downstream of the main CTs. (required when harmonic mode is intended to operate).
- At least 50% of the anticipated load should be available during the commissioning procedure. To fully test the system integration, all loads supported by the active filter system should be available for operation. The total output current required for the system must be at least 10% of the unit's nameplate rating. For example, a 300 A unit will need a minimum of 30 A Total Output current.
- If backup generation is connected to the active filter, the system should also be tested with the generator supporting the connected loads.

The Field Service Engineer will need to know the following information to commission the active filter:

- Installation location of the main CTs in relationship to the active filter (load or grid).
- The ratio of the main CTs installed.
- The phase on which each CT is installed.
- Intended mode of operation (Harmonic, Power Factor, Load Balancing).

Commissioning procedures

Refer to the User Manual for commissioning procedures. The User Manual is available as a download from our website.

Chapter 7 IT, HRG, and Corner Grounded Systems

This chapter provides information on using the active filter with Isolated Terra (IT), High Resistance Ground (HRG), and corner grounded systems.

DANGER

HAZARD OF ELECTRIC SHOCK, EXPLOSION, OR ARC FLASH

- Apply appropriate personal protective equipment (PPE) and follow safe electrical work practices. See NFPA 70E in the USA, CSA Z462, or applicable local standards.
- This equipment must be installed and serviced only by qualified electrical personnel.
- Do not exceed the device's ratings for maximum limits.
- Ground equipment using the ground connecting point provided before turning on any power supplying this device.
- Turn off all power supplying this device and the equipment in which it is installed before working on the device or equipment.
- After removing power, wait for 15 minutes to allow the capacitors to discharge prior to opening the doors or removing covers.
- Always use a properly rated voltage sensing device to confirm power is off.
- Replace all devices, doors, and covers before turning on power to this equipment.
- Carefully inspect the interior for tools left behind before closing and sealing the door.

Failure to follow these instructions will result in death or serious injury.

NOTICE

HAZARD OF EQUIPMENT DAMAGE

Open the IT/BP switches before operating the unit on an IT, HRG, or corner grounded system.

Failure to follow these instructions can result in equipment damage.

When connecting the active filter to an IT, HRG, or corner grounded system, open the IT/BP switches as follows:

1. Remove the large main cover of the unit.

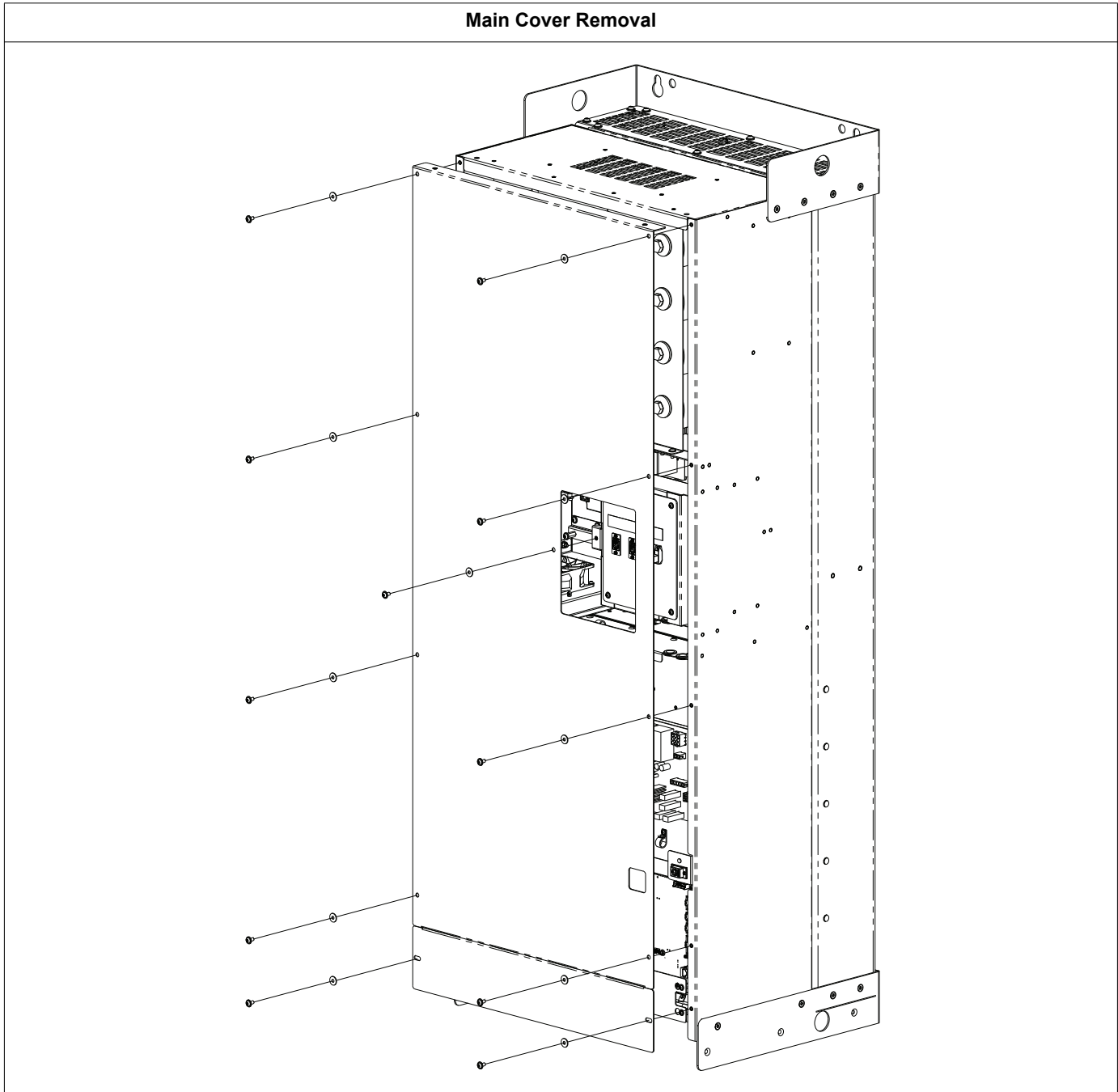

2. Locate the IT/BP switches.

IT/BP Switch Locations on 60 A and 120 A Units

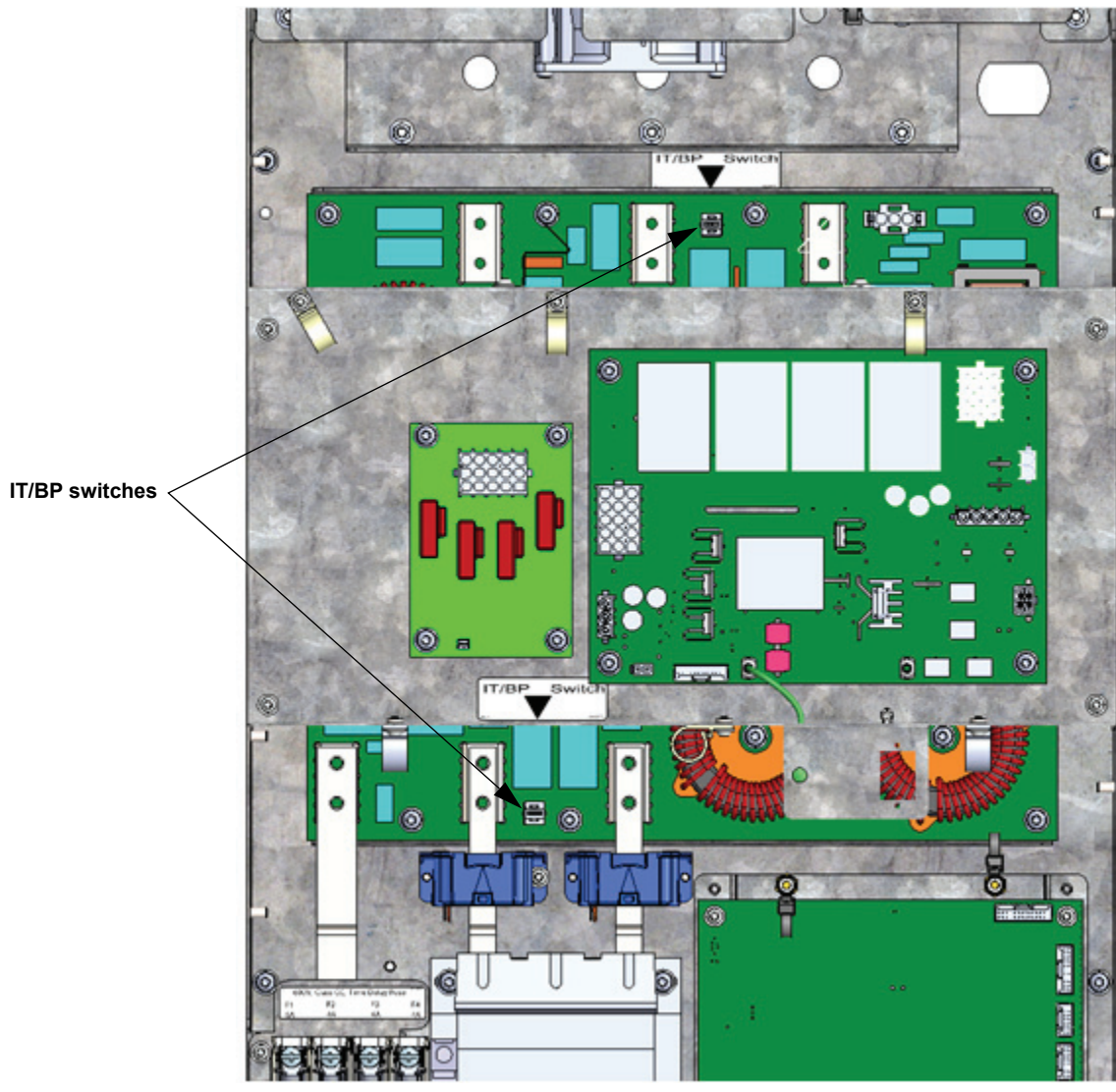

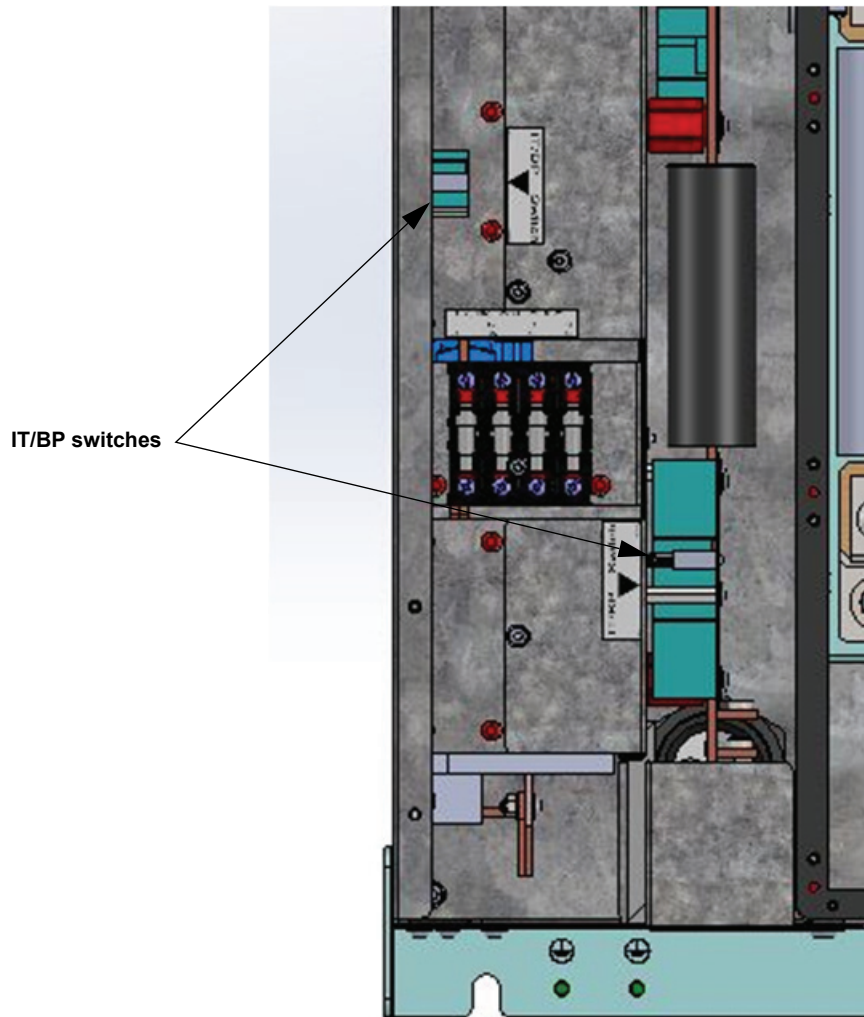
IT/BP Switch Locations on 200 A and 300 A Units

3. Pull the plunger out.

The switch is open when the plunger is completely out as shown here.

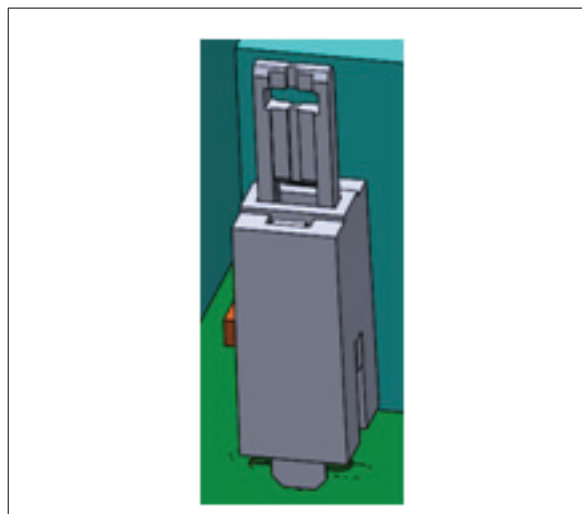

Chapter 8 IP00 chassis in a customer supplied enclosure

An IP00 chassis can be installed in other types of enclosures to provide a greater degree of environmental protection.

DANGER

HAZARD OF ELECTRIC SHOCK, EXPLOSION, OR ARC FLASH

- Apply appropriate personal protective equipment (PPE) and follow safe electrical work practices. See NFPA 70E in the USA, CSA Z462, or applicable local standards.
- This equipment must be installed and serviced only by qualified electrical personnel.
- Do not exceed the device's ratings for maximum limits.
- Ground equipment using the ground connecting point provided before turning on any power supplying this device.
- Turn off all power supplying this device and the equipment in which it is installed before working on the device or equipment.
- After removing power, wait for 15 minutes to allow the capacitors to discharge prior to opening the doors or removing covers.
- Always use a properly rated voltage sensing device to confirm power is off.
- Replace all devices, doors, and covers before turning on power to this equipment.
- Carefully inspect the interior for tools left behind before closing and sealing the door.

Failure to follow these instructions will result in death or serious injury.

The active filter consists of two sections, a power section and a control section.

The power section dissipates a significant amount of power, which must be evacuated to the outside of the enclosure. It is isolated by IP54 protections from the control section within the chassis. The chassis has a cooling fan to provide adequate airflow. Air inlets, outlets, and ductwork must be provided in the enclosure with the appropriate degree of protection required. The airflow must be at least equal to the values in the following table based on the amperage of the active filter.

Active Filter	Airflow Required m ³ /h (ft ³ /min)	Power Section Dissipation
60 A	370 (217.7)	1.04 kW
120 A	830 (488.3)	2.48 kW
200 A	1900 (1117.8)	4.92 kW
300 A	1900 (1117.8)	6.54 kW

The control section also has a fan for its cooling needs. It requires 200 m³/h (117.7 ft³/min) of air meeting Pollution Degree 2, i.e., does not contain conductive particles, significant amounts of dust or corrosive or otherwise harmful gases.

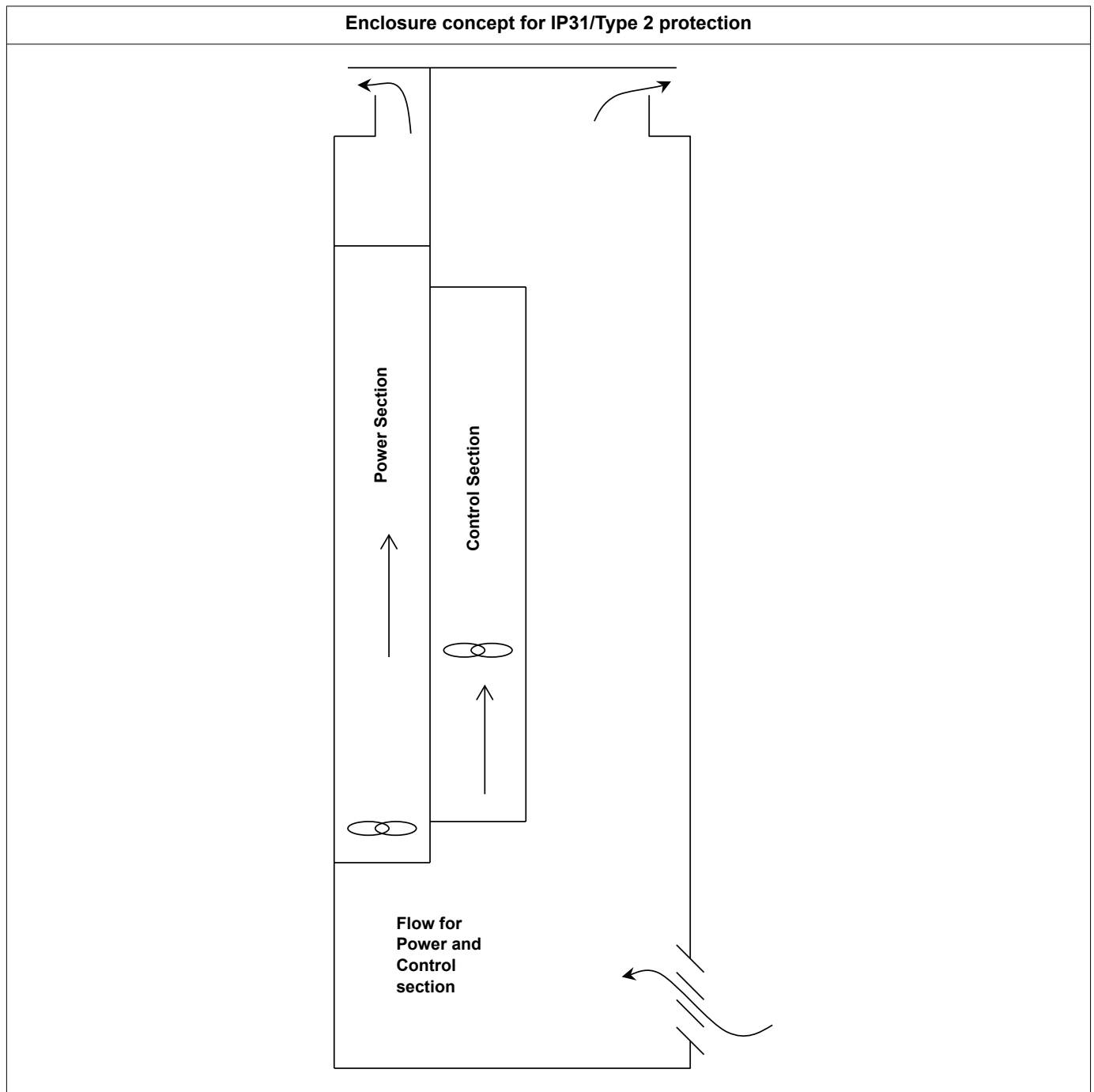

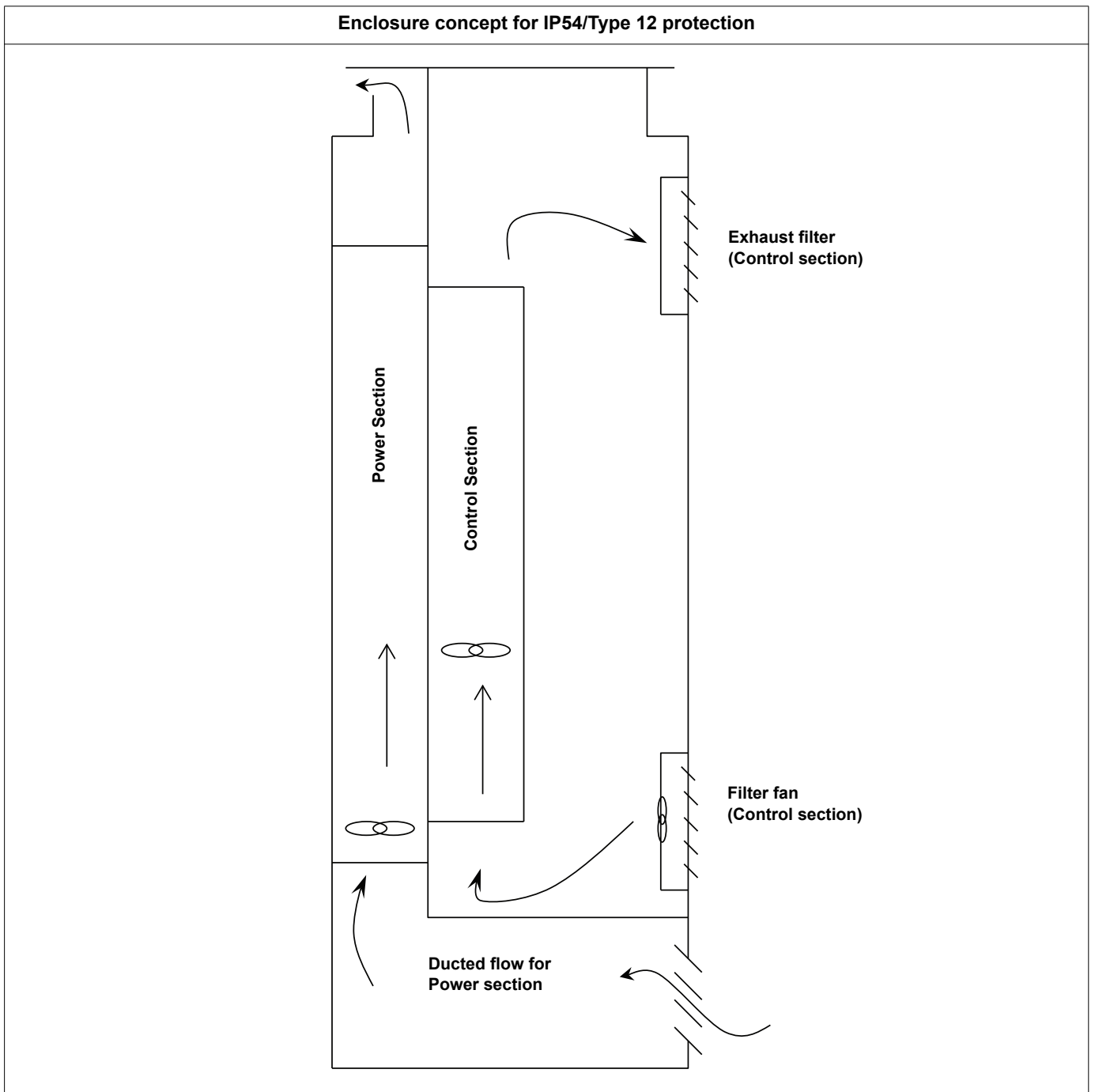

If the hot air exiting the filter is not ducted and evacuated to the outside, it can be recirculated back in, causing ineffective ventilation. To avoid this and help ensure serviceability, leave enough free space around the chassis as indicated in the following table and illustration.

Active Filter	Exhaust Free Space h1 mm (inches)	Inlet Free Space h2 mm (inches)
60 A	182 (7.17)	220 (8.66)
120 A	217 (8.54)	220 (8.66)
200 A	200 (7.87)	220 (8.66)
300 A	200 (7.87)	220 (8.66)

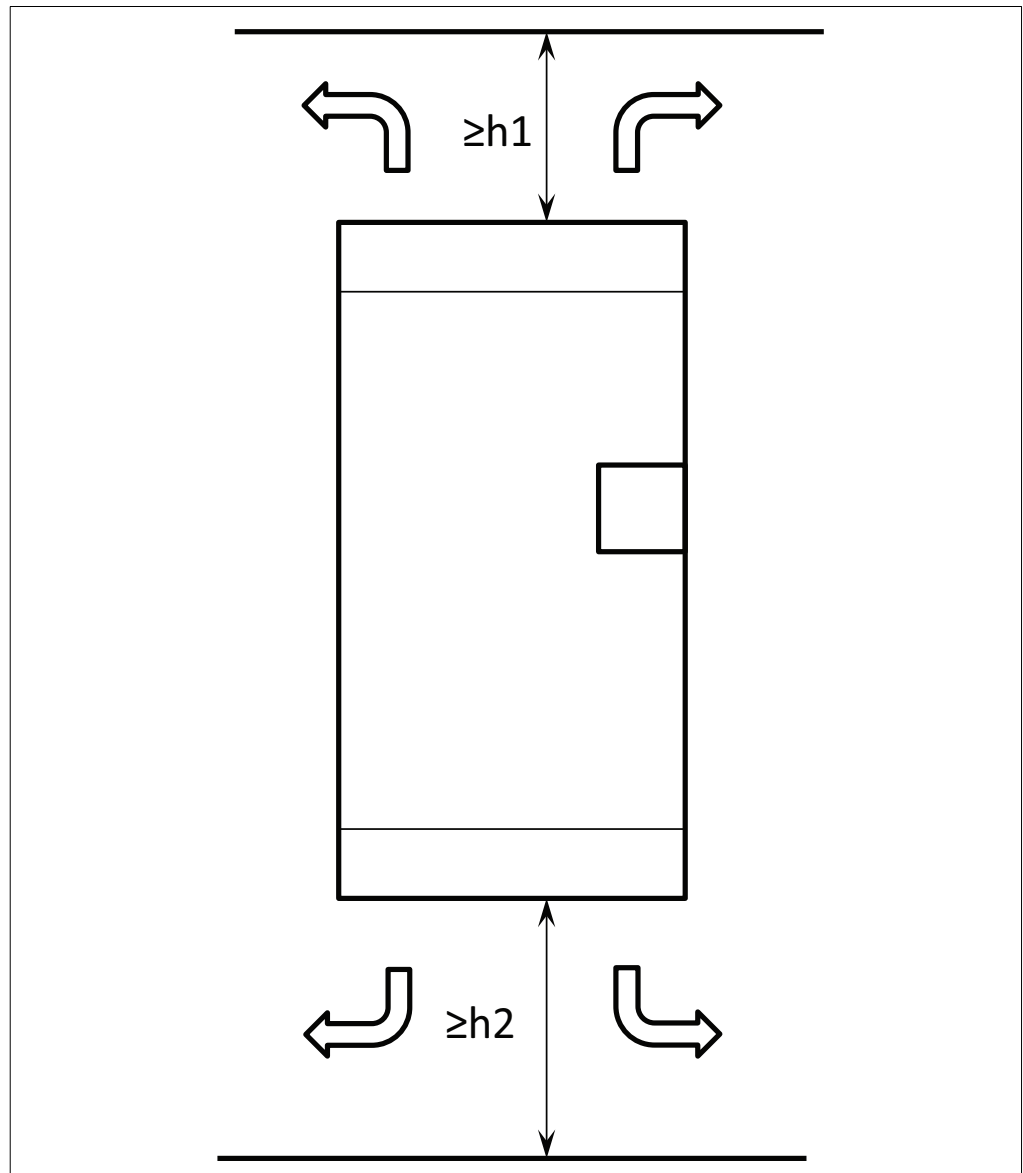

HMI Connections

When making the HMI connections, make sure it is mounted in a location that is accessible for users. HMI mounting instructions are provided in the box containing the HMI and interconnection wiring.

24 volt power

Make the 24 volt power connection as follows:

1. Connect the HMI power cable, which has a green connector on one end and a black connector on the other end.
 - Connect the green connector to the chassis green connector labeled PWR.
 - Connect the black connector to the HMI labeled DC24V.
2. Provide a ground wire from the HMI ground connection to the enclosure/chassis ground. The ground wire size must be between 0.2 to 1.5 mm² (24 - 16 AWG) with a temperature rating of 75°C (167°F).

Ethernet

Connect the green CAT5 cable labeled ETH to the active filter front connection labeled ETH.

Communication

Connect the black CAT5 cable labeled COM to the active filter front connection labeled COM. Connect the other end to the RJ45 connector on the HMI labeled COM1.

Enclosure mount USB

Provide a female USB that can be accessed by the user. Use a panel mount type A female to standard type A male. Connect the standard type A male to the USB A jack on the back of the HMI. Ensure that the panel mount type A female end is accessible to the end user. Use a USB cable that meets the requirement for the type of enclosure utilized.

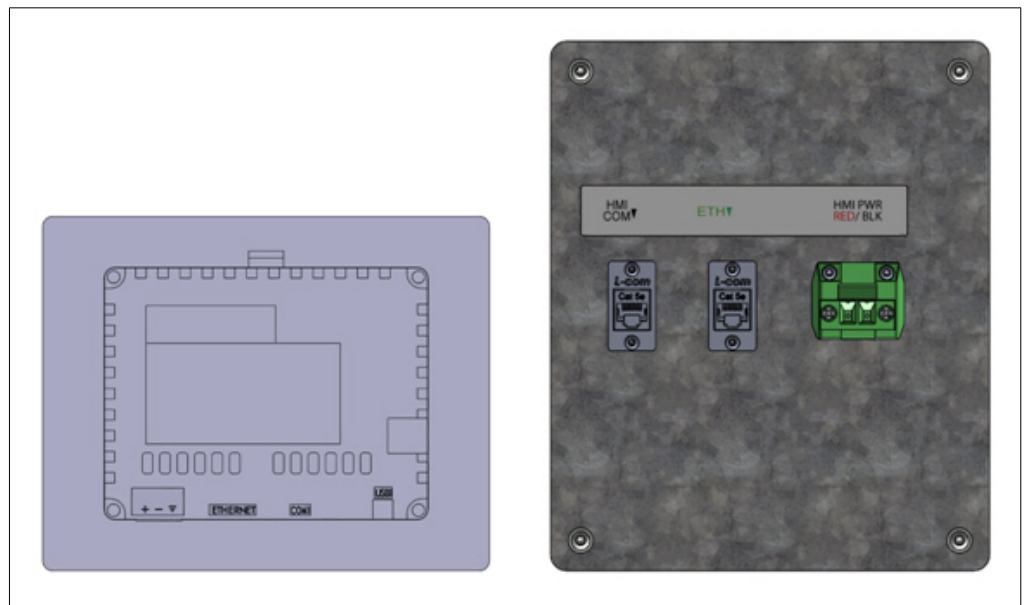

Dimensional Drawings

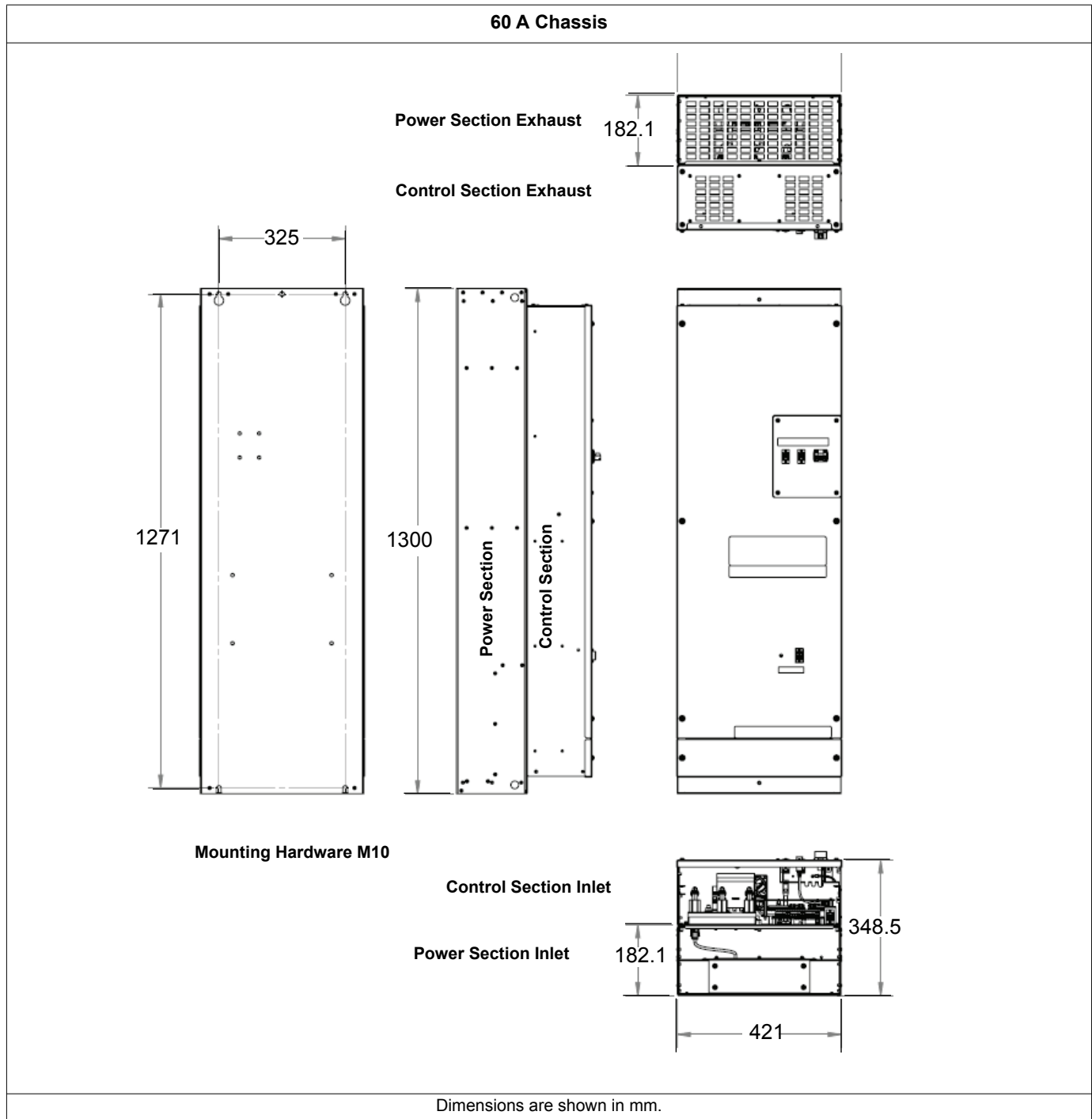

120 A Chassis

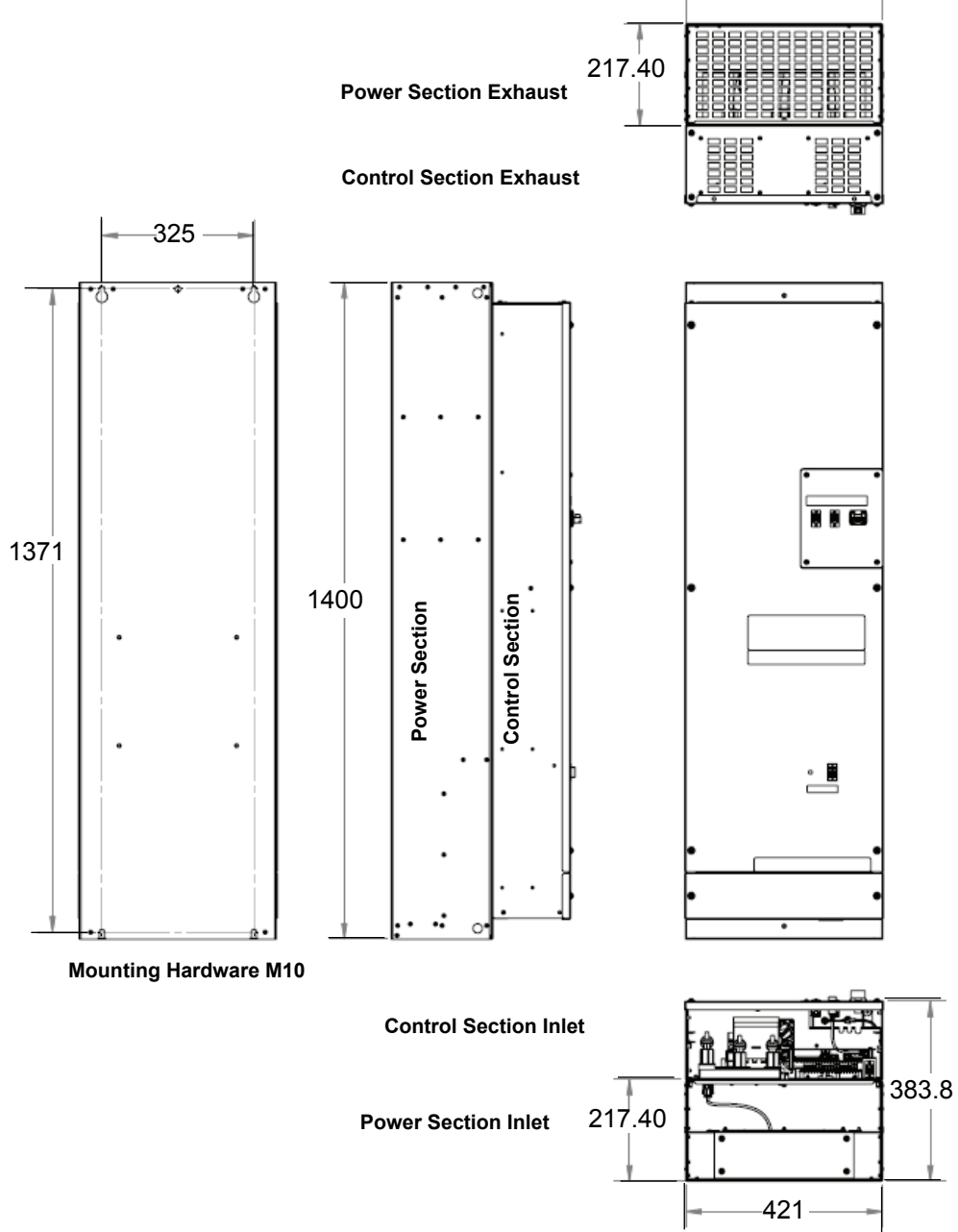

Dimensions are shown in mm.

200 A and 300 A Power Section Duct Dimensions

567 x 149.5 Rectangular Exhaust Duct

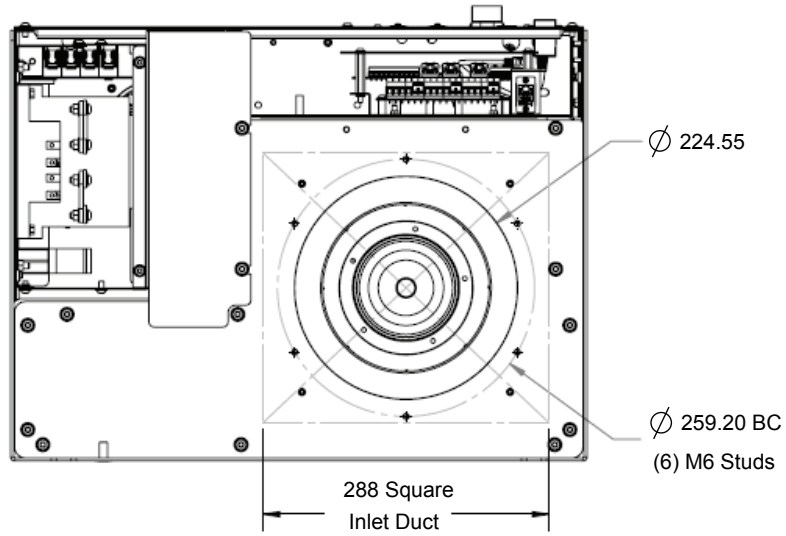
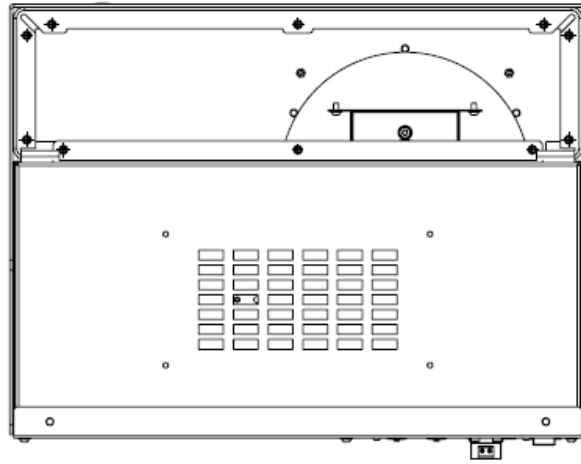

Dimensions are shown in mm.

Dimensions of 200 A and 300 A Exhaust Duct Flange

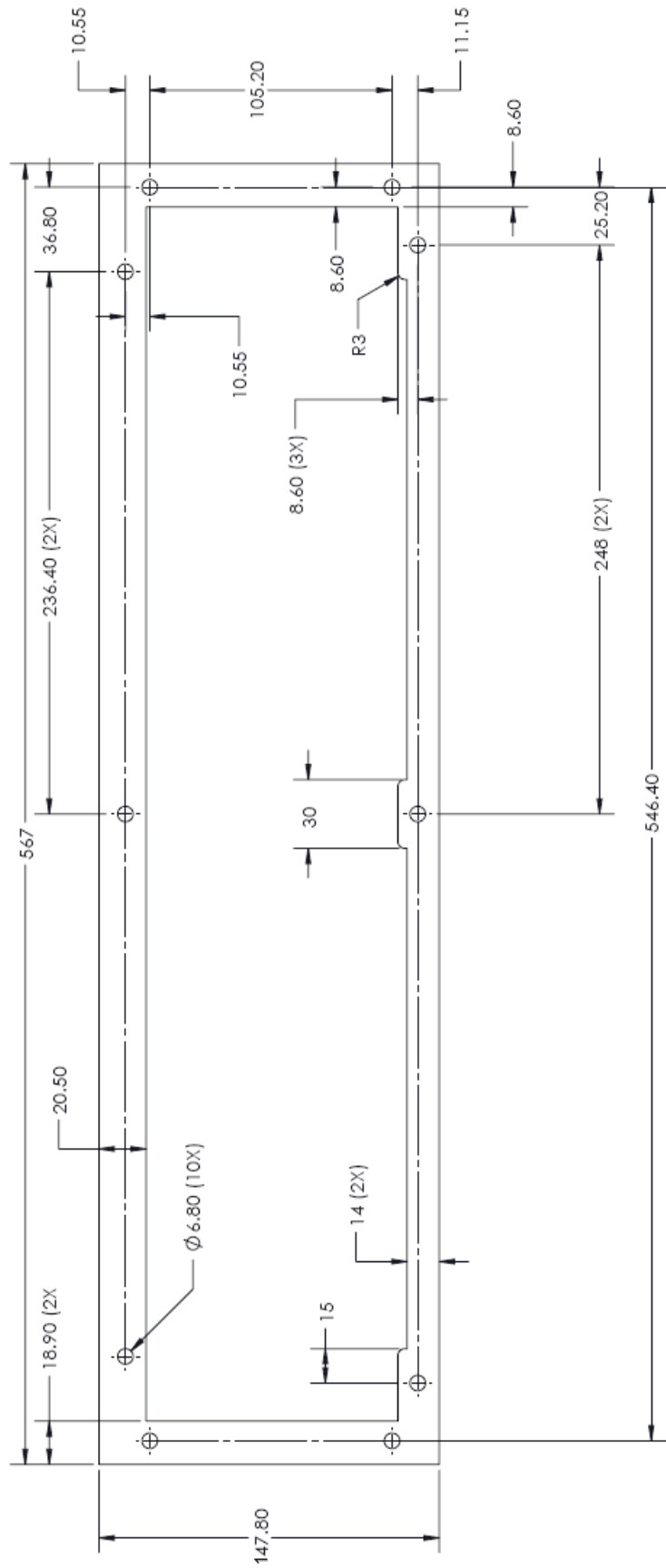

Dimensions are shown in mm.

Dimensions of 200 A and 300 A Inlet Duct Flange

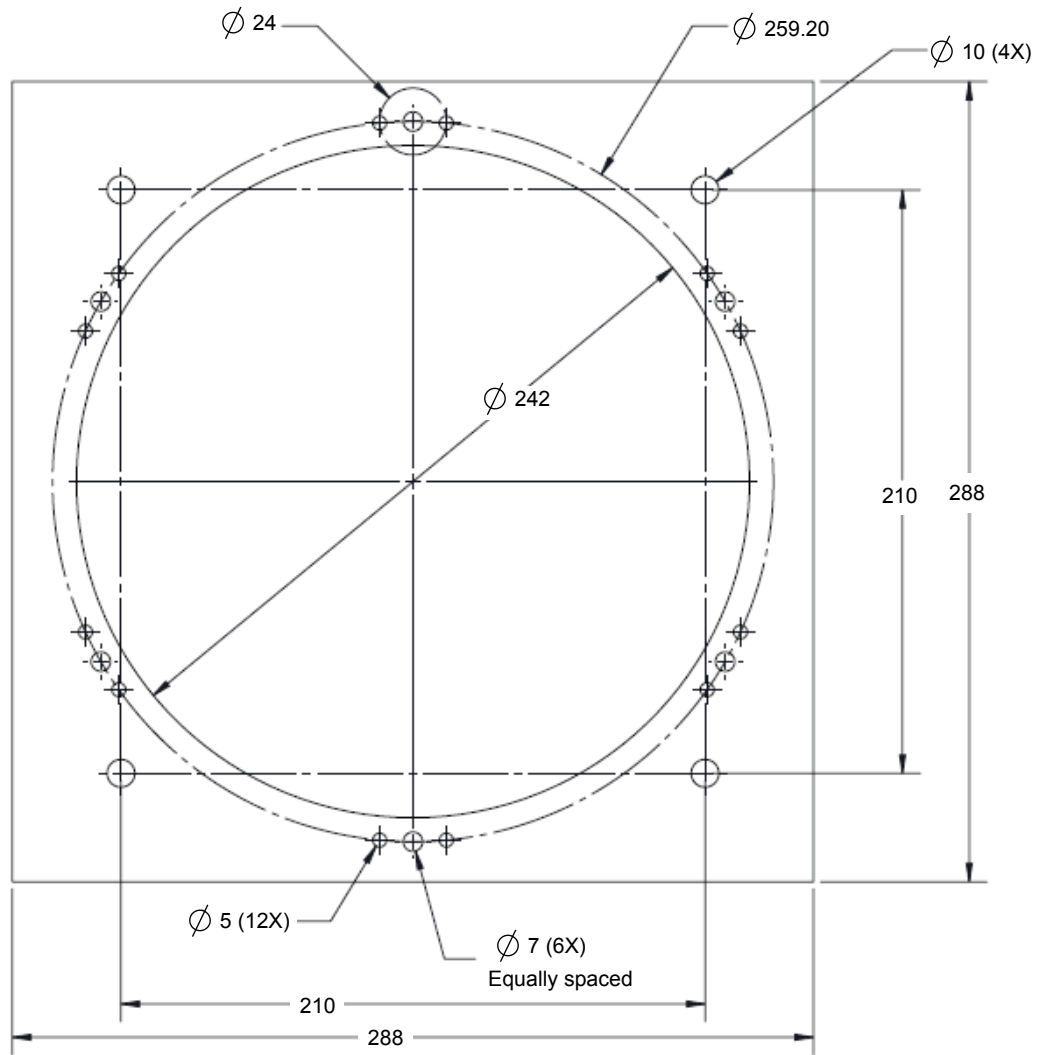

Dimensions are shown in mm.

Schneider Electric

35 rue Joseph Monier
92500 Rueil Malmaison - France
Phone: +33 (0) 1 41 29 70 00
www.schneider-electric.com

© 2015 Schneider Electric. All Rights Reserved.

NHA41798-01 08/2015

Schneider Electric, AccuSine, and Modbus are either trademarks or registered trademarks of Schneider Electric in France, the USA and other countries. Other trademarks used are the property of their respective owners.