

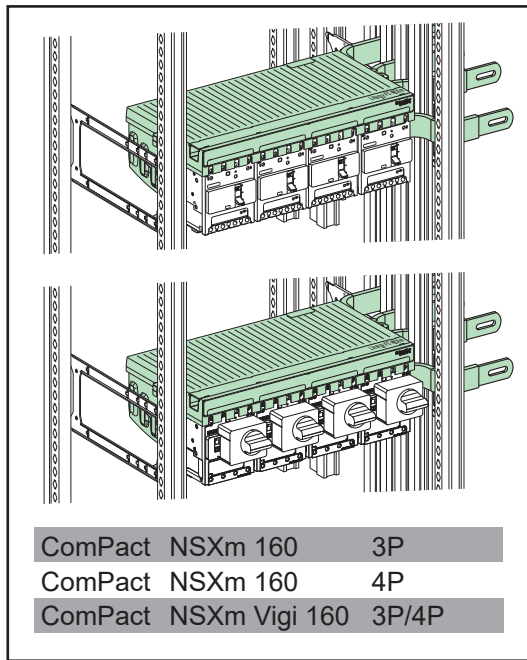

en fr es de it pt zh ru

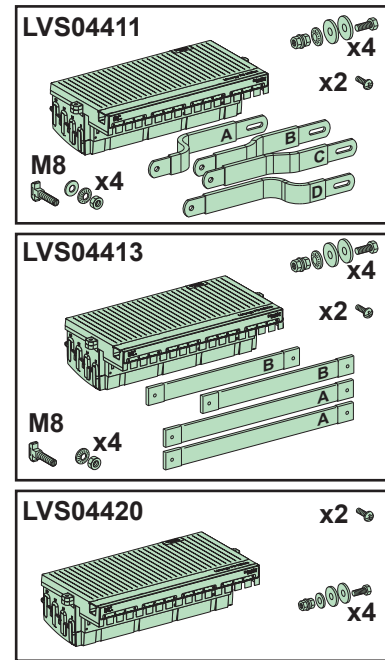

ComPact NSXm 160	3P
ComPact NSXm 160	4P
ComPact NSXm Vigi 160	3P/4P

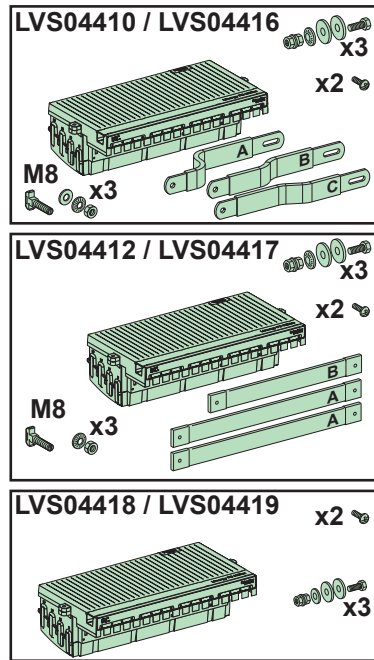

<p><b>PLEASE NOTE</b> Electrical equipment should be installed, operated, serviced, and maintained only by qualified personnel. No responsibility is assumed by Schneider Electric for any consequences arising out of the use of this material.</p>	<p><b>REMARQUE IMPORTANTE</b> L'installation, l'utilisation, la réparation et la maintenance des équipements électriques doivent être assurés uniquement par du personnel qualifié. Schneider Electric décline toute responsabilité quant aux conséquences de l'utilisation de ce matériel.</p>	<p><b>TENGA EN CUENTA</b> La instalación, manejo, puesta en servicio y mantenimiento de equipos eléctricos deberán ser realizados sólo por personal cualificado. Schneider Electric no se hace responsable de ninguna de las consecuencias del uso de este material.</p>	<p><b>BITTE BEACHTEN</b> Elektrische Geräte dürfen nur von Fachpersonal installiert, betrieben, bedient und gewartet werden. Schneider Electric haftet nicht für Schäden, die durch die Verwendung dieses Materials entstehen.</p>
<p><b>NOTA</b> Manutenzione, riparazione, installazione e uso delle apparecchiature elettriche si devono affidare solo a personale qualificato. Schneider Electric non si assume alcuna responsabilità per qualsiasi conseguenza derivante dall'uso di questo materiale.</p>	<p><b>NOTA</b> A instalação, utilização e manutenção do equipamento eléctrico devem ser efectuadas exclusivamente por pessoal qualificado. A Schneider Electric não assume qualquer responsabilidade pelas consequências resultantes da utilização deste material.</p>	<p><b>请注意</b> 电气设备的安装、操作、维修和维护工作仅限于合格人员执行。Schneider Electric 不承担由于使用本资料所引起的任何后果。</p>	<p><b>ОБРАТИТЕ ВНИМАНИЕ</b> Установка, эксплуатация, ремонт и обслуживание электрического оборудования может выполняться только квалифицированными электриками. Компания Schneider Electric не несет никакой ответственности за любые возможные последствия использования данной документации.</p>



<p>PrismaSeT switchboards equipped with the Linergy busbar connection system and Schneider Electric switchgear are subject to IEC 61439-1 &amp; 2 certification. The instructions in this document describe how to fit Linergy in a PrismaSeT switchboard. The installer is fully liable if it is fitted in any other switchboard.</p>	<p>Les tableaux PrismaSeT équipés du système de répartition, de connexion Linergy et d'appareillages Schneider Electric font l'objet d'une certification IEC61439-1 &amp; 2. Les instructions de ce document décrivent le montage de Linergy dans un tableau PrismaSeT. Le montage dans tout autre tableau est de la responsabilité du metteur en œuvre.</p>	<p>Los paneles PrismaSeT equipados con el sistema de distribución y conexión Linergy y con equipos Schneider Electric cuentan con la certificación IEC61439-1 &amp; 2. Las instrucciones de este documento describen el montaje de Linergy en el interior de un panel PrismaSeT. El montaje de dicho sistema en cualquier otro panel será responsabilidad del instalador.</p>	<p>Die PrismaSeT-Schaltanlage mit Verteilungssystem sowie Anschluss für Linergy-Systeme und Geräte von Schneider Electric sind gemäß IEC61439-1 &amp; 2 zertifiziert. Die Anweisungen in diesem Dokument beschreiben die Montage des Linergy-Systems in einer PrismaSeT-Schaltanlage. Die Montage in einer anderen Schaltanlage obliegt dem Nutzer.</p>
<p>I quadri PrismaSeT dotati di sistema di ripartizione e connessione Linergy e di apparecchiature Schneider Electric sono certificati secondo la norma IEC 61439-1 e 2. Le presenti istruzioni descrivono il montaggio di Linergy in un quadro PrismaSeT. Il montaggio in qualsiasi altro quadro ricade sotto la responsabilità dell'installatore.</p>	<p>Os quadros PrismaSeT equipados com o sistema de repartição e ligação Linergy e as aparelhagens Schneider Electric são objecto de uma certificação IEC61439-1 &amp; 2. A instruções deste documento descrevem a montagem de Linergy num quadro PrismaSeT. A montagem em qualquer outro quadro é da responsabilidade do instalador.</p>	<p>配有 Linergy 母线连接系统和 Schneider Electric 开关设备的 PrismaSeT 配电盘通过 IEC 61439-1 &amp; 2 认证。本文阐释如何在 PrismaSeT 配电盘中安装 Linergy。如果安装在任何其它配电盘中, 该安装程序也同样适用。</p>	<p>Распределительные щиты PrismaSeT, снабженные системой соединения сборной шины Linergy и распределительного устройства Schneider Electric, подпадают под сертификацию IEC 61439-1 и 2. Инструкции в данном документе объясняют как установить Linergy в распределительный щит PrismaSeT. Ответственность за установку в любой иной распределительный щит полностью лежит на монтажнике.</p>

▲ CAUTION / ATTENTION / ATENCIÓN / VORSICHT /  
ATTENZIONE / CUIDADO / ⚠️ / ВНИМАНИЕ

    	<p><b>RISK OF CUTTING</b></p> <ul style="list-style-type: none"> <li>Store the products in a dedicated and marked area.</li> <li>Wear personal protective equipment when handling and installing the products (gloves, long sleeved jacket, trousers, safety shoes, helmet, safety glasses).</li> </ul> <p><b>Failure to follow these instructions can result in injury or equipment damage.</b></p>	<p><b>RISQUE DE COUPURE</b></p> <ul style="list-style-type: none"> <li>Stockez les produits dans une zone dédiée et balisée.</li> <li>Utilisez des équipements individuels de protection lors de la manipulation et de l'installation des produits (gants, veste à manches longues, pantalon, chaussures de sécurité, casque, lunettes de sécurité).</li> </ul> <p><b>Si ces directives ne sont pas respectées, cela peut entraîner des blessures ou des dommages matériels.</b></p>	<p><b>RIESGO DE CORTES</b></p> <ul style="list-style-type: none"> <li>Almacene los productos en áreas específicas y señalizadas para ello.</li> <li>Utilice un equipo de protección personal cuando manipule e instale los productos (guantes, chaqueta de manga larga, pantalones, zapatos de seguridad, casco y gafas de seguridad).</li> </ul> <p><b>El incumplimiento de estas instrucciones puede causar lesiones o daño al equipo.</b></p>	<p><b>GEFÄHRDUNG DURCH SCHNEIDEN</b></p> <ul style="list-style-type: none"> <li>Lagern Sie die Produkte im dafür vorgesehenen, gekennzeichneten Bereich.</li> <li>Tragen Sie Schutzkleidung bei der Handhabung und Installation der Produkte (Handschuhe, Jacke mit langen Ärmeln, Hosen, Sicherheitsschuhe, Helm, Schutzbrille).</li> </ul> <p><b>Die Nichtbeachtung dieser Anweisungen kann Verletzungen oder Sachschäden zur Folge haben.</b></p>
	<p><b>RISCHIO DI TAGLIO</b></p> <ul style="list-style-type: none"> <li>Conservare i prodotti in un'area dedicata e contrassegnata.</li> <li>Indossare protezioni individuali adeguate per la manipolazione e l'installazione dei prodotti (guanti, giacche a manica lunga, pantaloni, calzature antinfortunistiche, elmetto, occhiali protettivi).</li> </ul> <p><b>Il mancato rispetto di queste istruzioni può provocare infortuni o danni alle apparecchiature.</b></p>	<p><b>RISCO DE CORTE</b></p> <ul style="list-style-type: none"> <li>Armezene os produtos numa área dedicada e assinalada.</li> <li>Use equipamento de protecção pessoal quando manusear e instalar os produtos (luvas, casaco de mangas compridas, calças, calçado de segurança, capacete, óculos de protecção).</li> </ul> <p><b>A não observância destas instruções pode provocar ferimentos pessoais, ou danos no equipamento.</b></p>	<p><b>割伤危险</b></p> <ul style="list-style-type: none"> <li>请在标明的专门区域存储本产品。</li> <li>搬运和安装产品时请穿戴个人防护装备（手套、长袖夹克、长裤、安全鞋、头盔、护目镜）。</li> </ul> <p><b>不遵循上述说明可能导致人身伤害或设备损坏。</b></p>	<p><b>РИСК ПОРЕЗОВ</b></p> <ul style="list-style-type: none"> <li>Храните изделия в специальном месте с маркировкой.</li> <li>Надевайте средства персональной защиты при погрузке-разгрузке и установке изделий (перчатки, куртку с длинными рукавами, брюки, защитную обувь, каску, защитные очки).</li> </ul> <p><b>Несоблюдение этих инструкций может привести к травме или повреждению оборудования.</b></p>

A

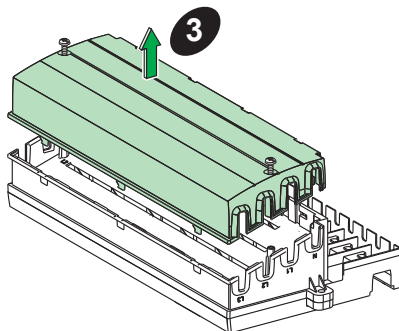
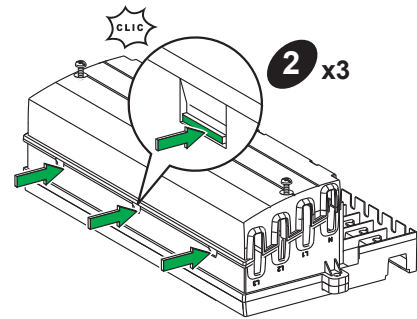
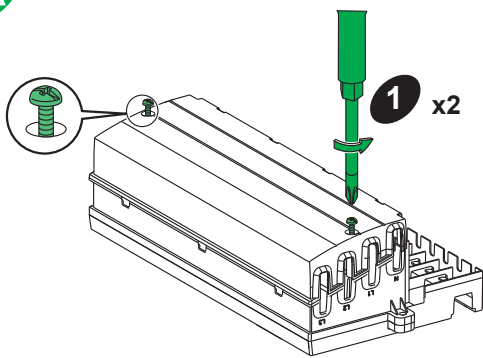

**B**

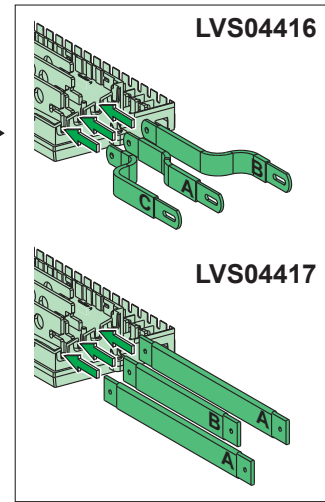
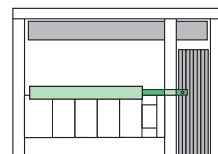
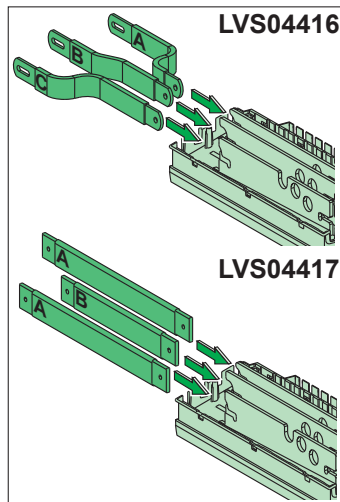
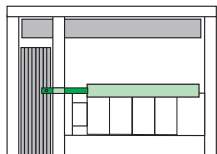
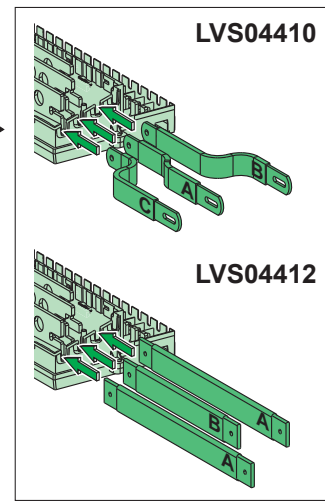
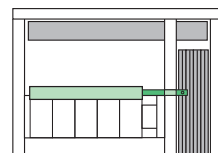
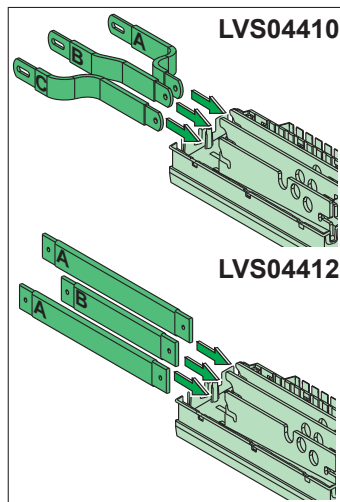
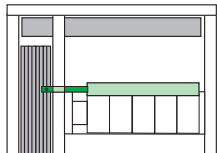
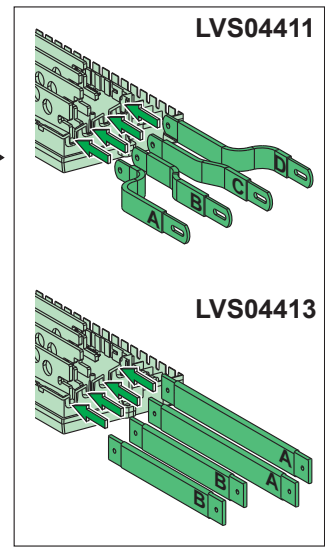
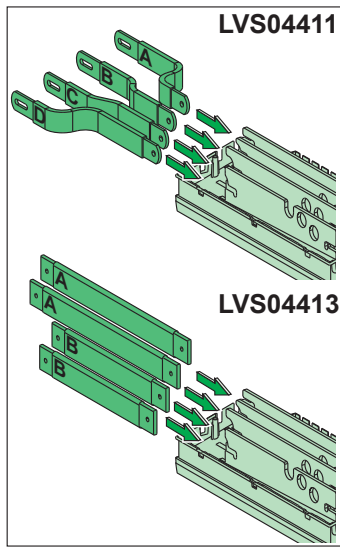
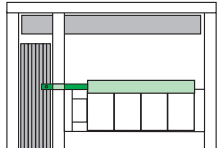

**C**

😊 x4

☹ x4

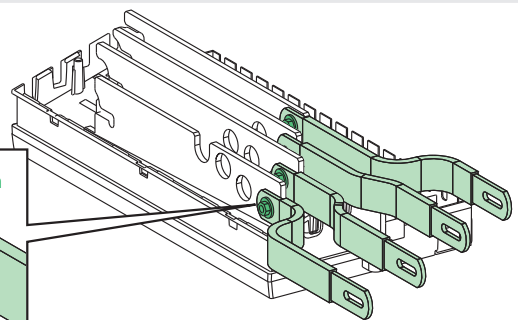
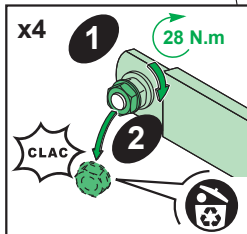
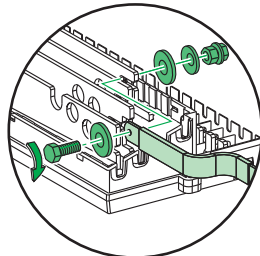
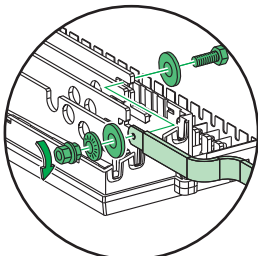

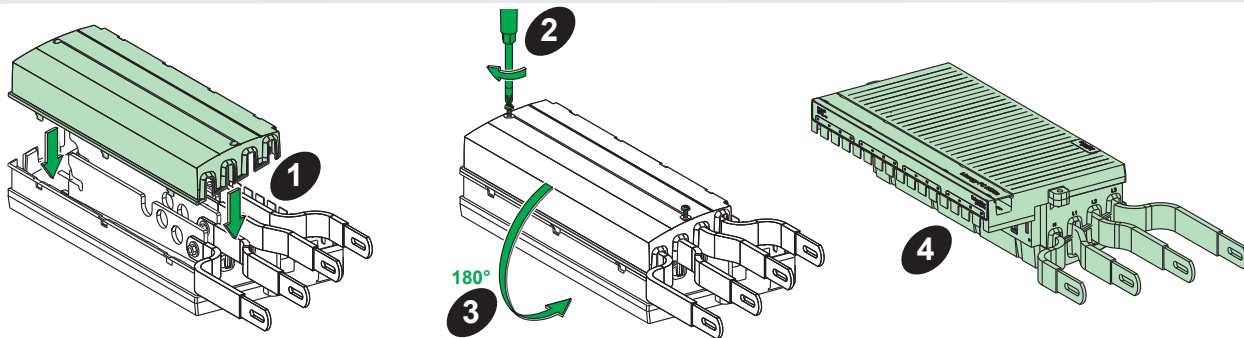
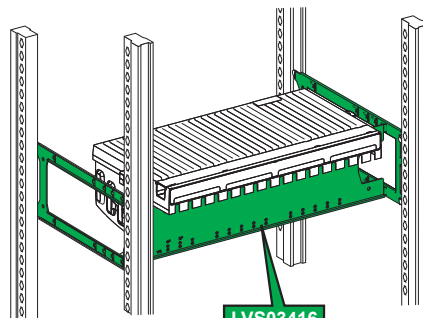
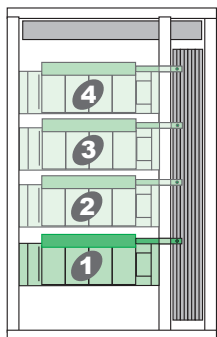
**D****E****i**

LVS03416

www.se.com

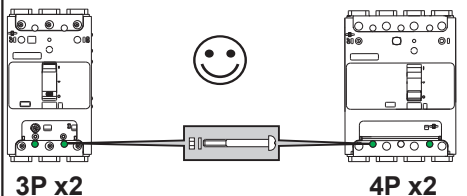

GDE12362

**F****i**

3P x2

4P x2

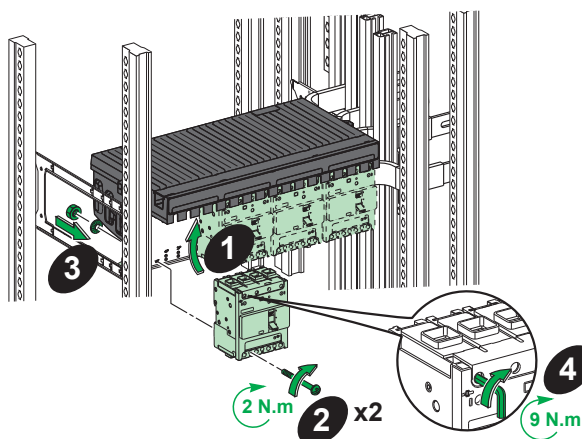

2 N.m

2 x2

9 N.m

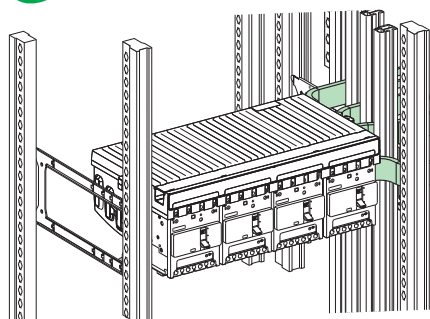
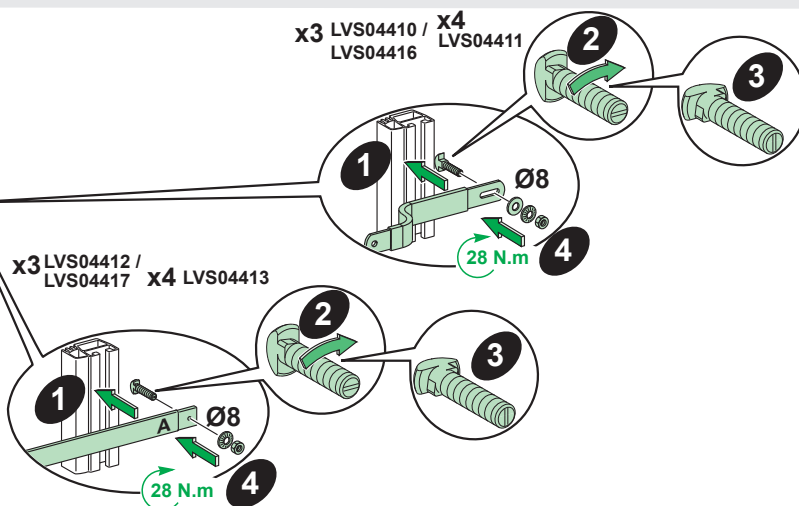
**G**x3 LVS04410 / x4 LVS04411  
LVS04416x3 LVS04412 / x4 LVS04413  
LVS04417

2

3

1

Ø8

28 N.m

4

2

3

1

Ø8

28 N.m

4

**H**

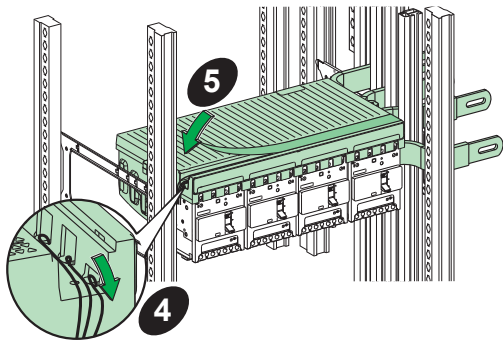
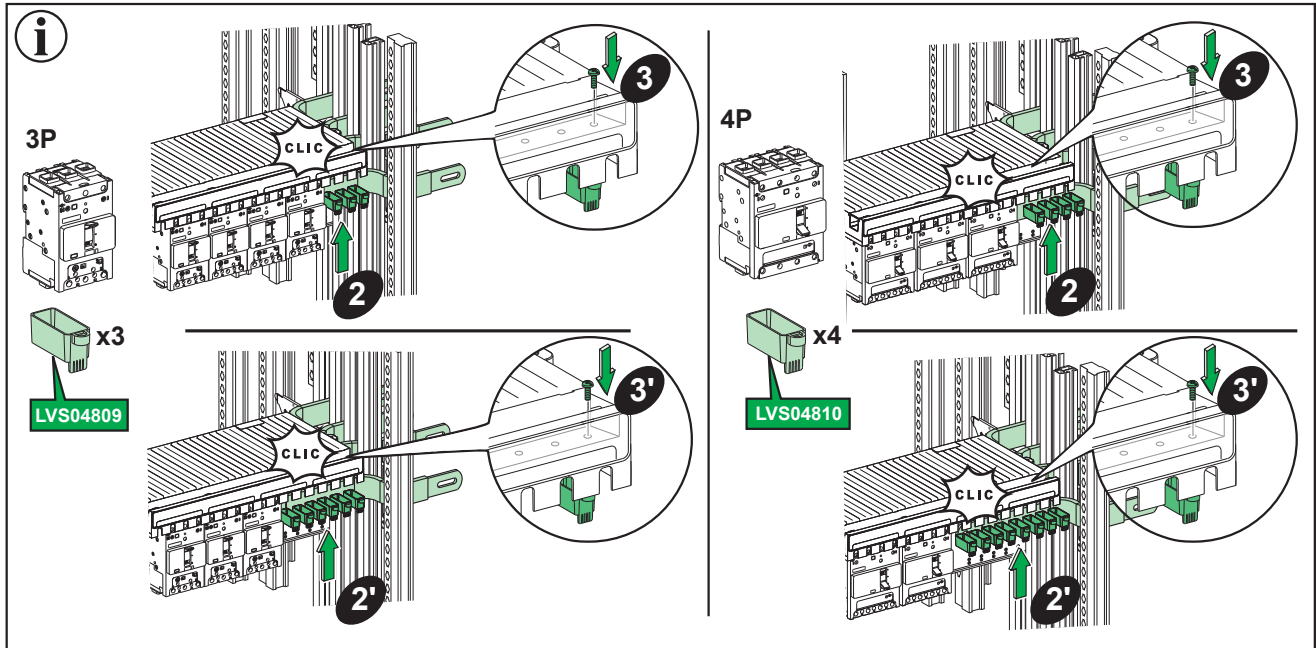
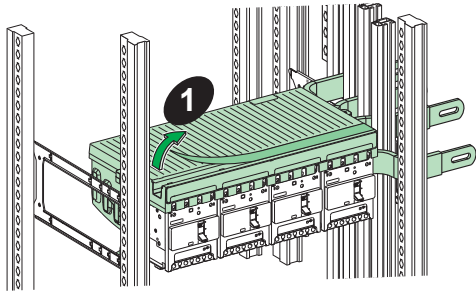

LVS04809 /  
LVS04810

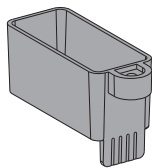

LVS03222 /  
LVS03249

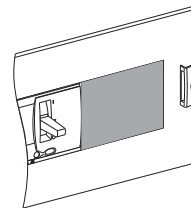

---

**Schneider Electric Industries SAS**  
35, rue Joseph Monier  
CS 30323  
F - 92506 Rueil Malmaison Cedex  
www.se.com

En raison de l'évolution des normes et du matériel, les caractéristiques indiquées par le texte et les images de ce document ne nous engagent qu'après confirmation par nos services.

*As standards, specifications and designs change from time to time, please ask for confirmation of the information given in this publication.*

Publication : Schneider Electric  
Réalisation :  
Impression :  
Format de pliage : 210 x 297 mm

© 2020 Schneider Electric - All rights reserved.



*Ce document a été imprimé sur du papier écologique.*

*This document has been printed on ecological paper.*