

Harmony Analog Temperature Signal Conditioner

RMPT1UUBD / RMTTC1UUBD

Contents / Sommaire / Inhalt / Índice / Sommario / 目录

1. Product Feature / Fonctionnalités du produit / Produktmerkmale / Característica del producto / Caratteristiche del prodotto / 产品特性.....	1
2. Safety Information / Informations de sécurité / Sicherheitshinweise / Información de seguridad / Informazioni di sicurezza / 安全信息.....	2
3. Mounting & Installation / Montage et installation / Montage und Installation / Montaje e instalación / Montaggio e installazione / 安装.....	3
4. Connection Example / Exemple de raccordement / Anschlussbeispiel / Ejemplo de conexión / Esempio di collegamento / 连接示例.....	3
5. Setting Instructions / Instructions de réglage / Einstellungsanweisungen / Instrucciones de ajuste / Istruzioni di configurazione / 设置说明.....	4
6. LED Indication & Diagnostic / Voyants LED et diagnostic / LED-Anzeige und -Diagnose / Indicaciones LED y diagnóstico / Indicazione e diagnostica a LED / LED 指示和诊断.....	6

1. Product Feature / Fonctionnalités du produit / Produktmerkmale / Característica del producto / Caratteristiche del prodotto / 产品特性

RMPT1UUBD / RMTTC1UUBD

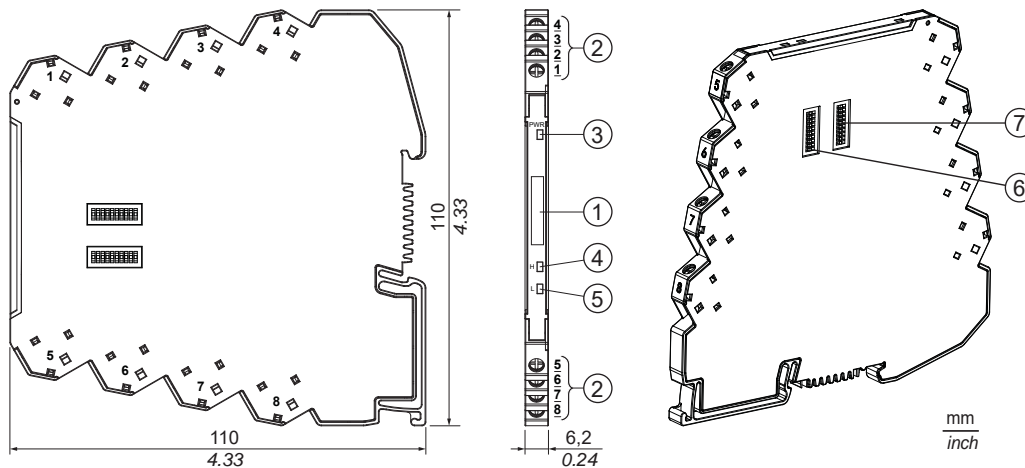

en

- ① Product part number
- ② Screw terminals
- ③ PWR - Green LED indicator for power
- ④ H - Red LED indicator for high input error
- ⑤ L - Red LED indicator for low input error
- ⑥ S1 DIP switch for configuration
- ⑦ S2 DIP switch for configuration

de

- ① Produkt-Teilenummer
- ② Schraubklemmen
- ③ PWR - Grüne LED-Anzeige für Spannungsversorgung
- ④ H - Rote LED-Anzeige für hohen Eingangsfehler
- ⑤ L - Rote LED-Anzeige für niedrigen Eingangsfehler
- ⑥ S1 DIP-Schalter zur Konfiguration
- ⑦ S2 DIP-Schalter zur Konfiguration

it

- ① Codice prodotto
- ② Morsetti a vite
- ③ PWR - Indicatore LED verde di alimentazione
- ④ H - Indicatore LED rosso per errore ingresso alto
- ⑤ L - Indicatore LED rosso per errore ingresso basso
- ⑥ DIP switch S1 per configurazione
- ⑦ DIP switch S2 per configurazione

fr

- ① Référence du produit
- ② Borniers à vis
- ③ PWR - Voyant LED vert pour l'alimentation
- ④ H - Voyant LED rouge pour une erreur d'entrée élevée
- ⑤ L - Voyant LED rouge pour une erreur d'entrée faible
- ⑥ Interrupteur DIP S1 pour la configuration
- ⑦ Interrupteur DIP S2 pour la configuration

es

- ① Referencia del producto
- ② Terminales de tornillo
- ③ PWR: indicador LED verde de potencia
- ④ H: indicador LED rojo de error de entrada alta
- ⑤ L: indicador LED rojo de error de entrada baja
- ⑥ Interruptor DIP S1 para configuración
- ⑦ Interruptor DIP S2 para configuración

zh

- ① 产品部件号
- ② 螺钉端子
- ③ PWR - 绿色 LED 指示灯, 用于指示电源
- ④ H - 红色 LED 指示灯, 用于指示高输入错误
- ⑤ L - 红色 LED 指示灯, 用于指示低输入错误
- ⑥ S1 用于配置的 DIP 开关
- ⑦ S2 用于配置的 DIP 开关

2. Safety Information / Informations de sécurité / Sicherheitshinweise / Información de seguridad / Informazioni di sicurezza / 安全信息

⚠️ ⚠️ DANGER	⚠️ ⚠️ DANGER	⚠️ ⚠️ GEFAHR	⚠️ ⚠️ PELIGRO	⚠️ ⚠️ PERICOLO	⚠️ ⚠️ 危险
<p>HAZARD OF ELECTRIC SHOCK, EXPLOSION OR ARC FLASH</p> <ul style="list-style-type: none"> - Disconnect all power before servicing equipment. - Confirm that the product power supply voltage and its tolerances are compatible with those of the network. <p>Failure to follow these instructions will result in death or serious injury.</p>	<p>RISQUE D'ELECTROCUTION, D'EXPLOSION OU D'ARC ELECTRIQUE</p> <ul style="list-style-type: none"> - Couper toutes les alimentations avant d'intervenir sur cet appareil. - Assurez-vous que la tension d'alimentation du produit, avec ses tolérances, est compatible avec celle du réseau. <p>Le non-respect de ces instructions entraînera la mort ou des blessures graves.</p>	<p>STROMSCHLAG-, EXPLOSIONS- ODER LICHTBOGENGEFAHR</p> <ul style="list-style-type: none"> - Vor dem Arbeiten an dem Gerätessen Stromversorgung abschalten. - Stelle Sie sicher, dass die Versorgungsspannung des Produkts einschließlich Toleranzen mit den Netzbedingungen vereinbar ist. <p>Die Nichtbeachtung dieser Anweisung wird den Tod oderschwere Körperverletzung zur Folge haben.</p>	<p>RIESGO DE ELECTROCUCIÓN, EXPLOSIÓN O ARCO ELÉCTRICO</p> <ul style="list-style-type: none"> - Desconecte toda alimentación antes de realizar el servicio. - Asegúrese de que la tensión de alimentación del producto y sus tolerancias son compatibles con las de la red eléctrica. <p>Si no se siguen estas instrucciones, provocará lesiones graves o incluso la muerte.</p>	<p>RISCHIO DI SCOSSA ELETTRICA, ESPLOSIONE O ARCO ELETTRICO</p> <ul style="list-style-type: none"> - Scollegare l'apparecchio dalla presa di corrente prima di qualsiasi intervento. - Assicurarsi che la tensione di alimentazione del prodotto e le relative tolleranze sia compatibile con quelle della rete. <p>Il mancato rispetto di queste istruzioni provocherà morte o gravi infortuni.</p>	<p>存在电击、爆炸或电弧危险</p> <ul style="list-style-type: none"> - 维修设备前，请断开所有电源连接。 - 确认产品电源电压及其公差兼容于网络的这些参数。 <p>如果不遵守这些说明，将会导致死亡或严重伤害。</p>
⚠️ WARNING	⚠️ AVERTISSEMENT	⚠️ WARNUNG	⚠️ ADVERTENCIA	⚠️ AVVERTENZA	⚠️ 警告
<p>UNINTENDED EQUIPMENT OPERATION</p> <ul style="list-style-type: none"> - Do not use in safety critical system. - Do not disassemble, repair or modify the product. - Install the product in the operating environment conditions described in this document. - Use copper conductors only. <p>Failure to follow these instructions can result in death or serious injury.</p>	<p>FONCTIONNEMENT IMPRÉVU DE L'ÉQUIPEMENT</p> <ul style="list-style-type: none"> - Ne pas utiliser dans un système où la sécurité est critique. - Ce produit ne doit être ni démonté, ni réparé, ni modifié. - Installez le produit dans les conditions d'environnement d'exploitation, comme indiqué dans le présent document. - Utilisez uniquement des conducteurs en cuivre. <p>Le non-respect de ces instructions peut entraîner des blessures graves, voire mortelles.</p>	<p>UNBEABSICHTIGTER GERÄTEBETRIEB</p> <ul style="list-style-type: none"> - Verwenden Sie das Produkt nicht in sicherheitskritischen Systemen. - Das Produkt darf weder zerlegt noch repariert oder verändert werden. - Installieren Sie das Produkt in einer Betriebsumgebung, die den in diesem Dokument beschriebenen Betriebsumgebungsbedingungen entspricht. - Verwenden Sie ausschließlich Kupferleiter. <p>Bei Nichtbeachtung dieser Anweisungen kann es zu schweren oder sogar tödlichen Verletzungen kommen.</p>	<p>FUNCIONAMIENTO IMPREVISTO DEL EQUIPO</p> <ul style="list-style-type: none"> - No utilizar en sistemas críticos para la seguridad. - No desmonte, repare ni modifique este producto. - Instale el producto en las condiciones de entorno de funcionamiento descritas en este documento. - Utilice solamente conductores de cobre. <p>De no seguir estas instrucciones, se pueden producir la muerte o lesiones graves.</p>	<p>FUNZIONAMENTO IMPREVISTO DELL'APPARECCHIATURA</p> <ul style="list-style-type: none"> - Non utilizzare in un sistema critico per la sicurezza. - Non smontare, riparare o modificare il prodotto. - Installare il prodotto nelle condizioni ambientali di funzionamento descritte nel presente documento. - Utilizzare solo fili di rame. <p>Il mancato rispetto di queste istruzioni può provocare lesioni gravi o mortali.</p>	<p>意外的设备操作</p> <ul style="list-style-type: none"> - 请勿在安全攸关系统中使用。 - 切勿拆卸、修理或修改本产品。 - 请在本文件所述的工作环境条件下安装本产品。 - 仅使用铜导线。 <p>不遵守这些说明可能会导致死亡或严重受伤。</p>
<p>Electrical equipment should be installed, operated, serviced, and maintained only by qualified personnel. No responsibility is assumed by Schneider Electric for any consequences arising out of the use of this material.</p>	<p>Les équipements électriques doivent être installés, exploités et entretenus par un personnel qualifié. Schneider Electric n'assume aucune responsabilité des conséquences éventuelles découlant de l'utilisation de cette documentation.</p>	<p>Elektrische Geräte dürfen nur von Fachpersonal installiert, betrieben, gewartet und instand gesetzt werden. Schneider Electric haftet nicht für Schäden, die aufgrund der Verwendung dieses Materials entstehen.</p>	<p>Sólo el personal de servicio cualificado podrá instalar, utilizar, reparar y mantener el equipo eléctrico. Schneider Electric no asume las responsabilidades que pudieran surgir como consecuencia de la utilización de este material.</p>	<p>Le apparecchiature elettriche devono essere installate, usate e riparate solo da personale qualificato. Schneider Electric non assume nessuna responsabilità per qualunque conseguenza derivante dall'uso di questo materiale.</p>	<p>电气设备的安装、操作、维修和维护工作仅限于合格人员执行。对于超出本资料所引发的任何后果，Schneider Electric 概不负责。</p>
<p>UK CA</p> <p>UK representative: Schneider Electric Limited Stafford Park 5 Telford, TF3 3BL, UK</p>					

3. Mounting & Installation / Montage et installation / Montage und Installation / Montaje e instalación / Montaggio e installazione / 安装

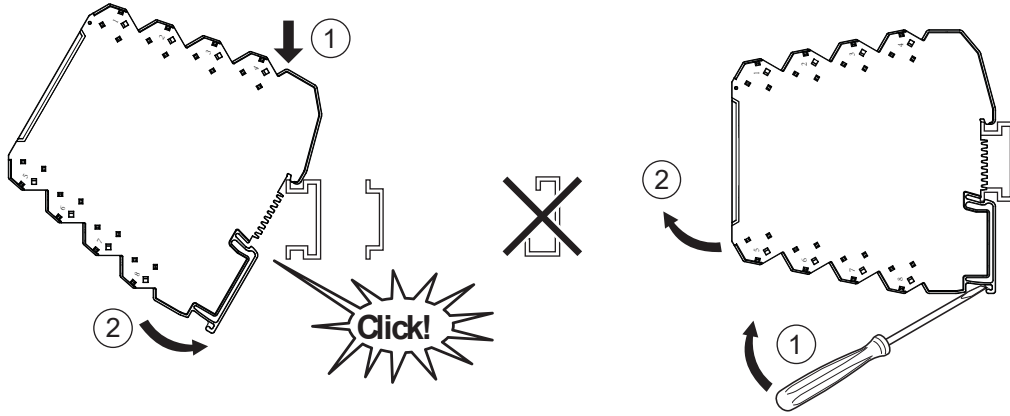

mm	8...9		
inch	0.31...0.35		
mm ²		0.5...2.5	0.5...2.5
AWG		20...14	20...14

	Ø 3,5 mm / 0.14 in		N.m	0,4...0,5
			lbf.in	3.5...4.4

Rail 35 mm / 1.38 in →
 Rail 35 mm / 1.38 in →
 Schiene 35 mm / 1.38 in →
 Riel 35 mm / 1.38 in →
 Guida 35 mm / 1.38 in →
 导轨 35 毫米 / 1.38 英寸 →

} IEC/EN 60715

4. Connection Example / Exemple de raccordement / Anschlussbeispiel / Ejemplo de conexión / Esempio di collegamento / 连接示例

- (a) RTD
- (b) Thermocouple / Thermocouple / Thermoelement / Termopar / Termocoppia / 热电偶

RMPT1UUBD

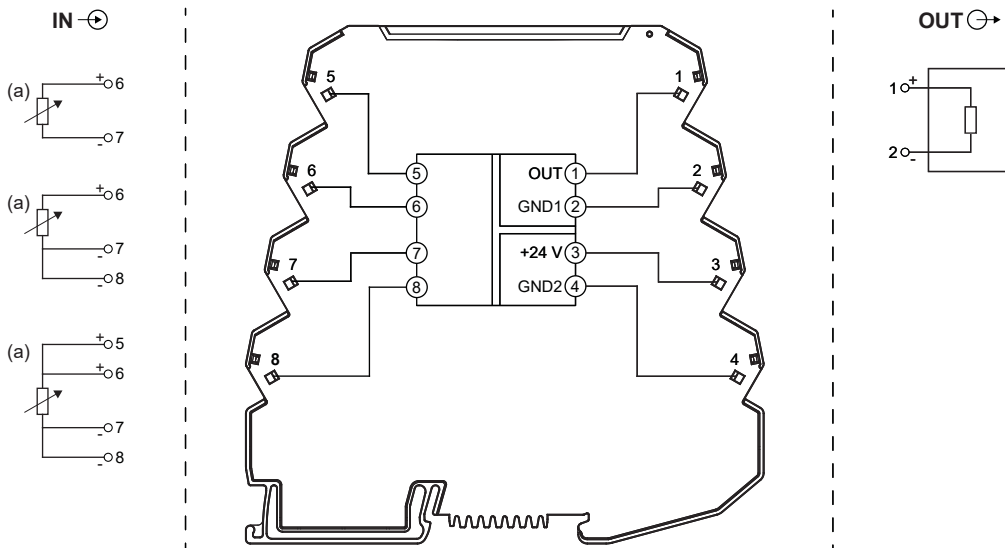

RMTC1UUBD

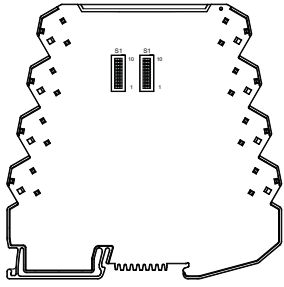

- Off / Eteinte / Erlöschen / Apagado / Spenta / 关闭
- On / Allumée / Brennt / Encendido / Accesa / 开启
- * Default / Par défaut / Standard / Valor predeterminado / Predefinito / 默认
- Response Time / Temps de réponse / Antwortzeit / Tiempo de respuesta / Tempo di risposta / 响应时间
- Invalid Setting / Paramètre incorrect / Ungültige Einstellung / Configuración no válida / Impostazione non valida / 无效的设置
- Sensor Type / Type de capteur / Sensortyp / Tipo de sensor / Tipo di sensore / 传感器类型
- Diagnostics / Diagnostic / Diagnose / Diagnóstico / Diagnostica / 诊断
- Ts Start Temperature / Température de départ / Starttemperatur / Temperatura inicial / Temperatura iniziale / 起始温度
- Te End Temperature / Température de fin / Endtemperatur / Temperatura final / Temperatura finale / 结束温度
- LL Measurement Lower Limit / Limite inférieure de la mesure / Messung Untergrenze / Límite inferior de medidas / Limite di misurazione inferiore / 测量下限
- LU Measurement Upper Limit / Limite supérieure de la mesure / Messung Obergrenze / Límite superior de medidas / Limite di misurazione superiore / 测量上限
- LB Line Break / Coupure / Leitungsbruch / Circuito abierto / Interruzione di linea / 断线

S1

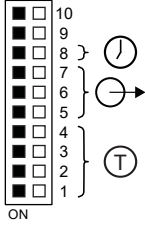

S1	1	2	3	4
K*	<input type="checkbox"/>	<input type="checkbox"/>	<input type="checkbox"/>	<input type="checkbox"/>
J	<input type="checkbox"/>	<input type="checkbox"/>	<input type="checkbox"/>	<input type="checkbox"/>
B	<input type="checkbox"/>	<input type="checkbox"/>	<input type="checkbox"/>	<input type="checkbox"/>
E	<input type="checkbox"/>	<input type="checkbox"/>	<input type="checkbox"/>	<input type="checkbox"/>
N	<input type="checkbox"/>	<input type="checkbox"/>	<input type="checkbox"/>	<input type="checkbox"/>
R	<input type="checkbox"/>	<input type="checkbox"/>	<input type="checkbox"/>	<input type="checkbox"/>
S	<input type="checkbox"/>	<input type="checkbox"/>	<input type="checkbox"/>	<input type="checkbox"/>
T	<input type="checkbox"/>	<input type="checkbox"/>	<input type="checkbox"/>	<input type="checkbox"/>
L	<input type="checkbox"/>	<input type="checkbox"/>	<input type="checkbox"/>	<input type="checkbox"/>

S1	5	6	7			
0...20 mA*	<input type="checkbox"/>	<input type="checkbox"/>	<input type="checkbox"/>			
4...20 mA	<input type="checkbox"/>	<input type="checkbox"/>	<input checked="" type="checkbox"/>			
0...10 V	<input type="checkbox"/>	<input checked="" type="checkbox"/>	<input type="checkbox"/>			
2...10 V	<input type="checkbox"/>	<input checked="" type="checkbox"/>	<input checked="" type="checkbox"/>			
0...5 V	<input type="checkbox"/>	<input type="checkbox"/>	<input type="checkbox"/>			
1...5 V	<input checked="" type="checkbox"/>	<input type="checkbox"/>	<input type="checkbox"/>			

S1	8
500 ms*	<input type="checkbox"/>
250 ms	<input checked="" type="checkbox"/>

9	10	LL	LU	LB
<input type="checkbox"/>	<input type="checkbox"/>	LL - 5%*	LU + 4%*	LU + 10%*
<input type="checkbox"/>	<input checked="" type="checkbox"/>	LL - 5%*	LU + 4%	LU + 4%
<input checked="" type="checkbox"/>	<input type="checkbox"/>	LL + 0%	LU + 0%	LU + 4%
<input checked="" type="checkbox"/>	<input checked="" type="checkbox"/>	LL + 0%	LU + 0%	LL + 0%

*Applicable to 4-20 mA, 2-10 V and 1-5 V output setting
 *Applicable uniquement au paramètre des sorties 4-20 mA, 2-10 V et 1-5 V
 *Gilt nur für die Ausgangseinstellungen 4-20 mA, 2-10 V und 1-5 V
 *Aplicable solo a la configuración de salida de 4-20 mA, 2-10 V y 1-5 V
 *Applicable solo all'impostazione di uscita 4-20 mA, 2-10 V e 1-5 V
 *仅适用于 4-20 mA、2-10 V 和 1-5 V 输出设置

S2

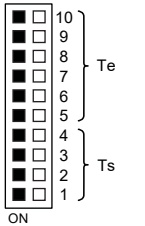

Ts	1	2	3	4
-200	<input type="checkbox"/>	<input type="checkbox"/>	<input type="checkbox"/>	<input type="checkbox"/>
-180	<input type="checkbox"/>	<input type="checkbox"/>	<input type="checkbox"/>	<input checked="" type="checkbox"/>
-150	<input type="checkbox"/>	<input type="checkbox"/>	<input type="checkbox"/>	<input type="checkbox"/>
-100	<input type="checkbox"/>	<input type="checkbox"/>	<input type="checkbox"/>	<input type="checkbox"/>
-50	<input type="checkbox"/>	<input checked="" type="checkbox"/>	<input type="checkbox"/>	<input type="checkbox"/>
-25	<input type="checkbox"/>	<input type="checkbox"/>	<input checked="" type="checkbox"/>	<input type="checkbox"/>
-10	<input type="checkbox"/>	<input checked="" type="checkbox"/>	<input type="checkbox"/>	<input type="checkbox"/>
-5	<input type="checkbox"/>	<input type="checkbox"/>	<input type="checkbox"/>	<input checked="" type="checkbox"/>
0	<input checked="" type="checkbox"/>	<input type="checkbox"/>	<input type="checkbox"/>	<input type="checkbox"/>
5	<input checked="" type="checkbox"/>	<input type="checkbox"/>	<input type="checkbox"/>	<input type="checkbox"/>
10	<input checked="" type="checkbox"/>	<input type="checkbox"/>	<input type="checkbox"/>	<input type="checkbox"/>
20	<input checked="" type="checkbox"/>	<input type="checkbox"/>	<input type="checkbox"/>	<input type="checkbox"/>
25	<input checked="" type="checkbox"/>	<input type="checkbox"/>	<input type="checkbox"/>	<input type="checkbox"/>
50	<input checked="" type="checkbox"/>	<input type="checkbox"/>	<input type="checkbox"/>	<input type="checkbox"/>
100	<input checked="" type="checkbox"/>	<input type="checkbox"/>	<input type="checkbox"/>	<input type="checkbox"/>
200	<input checked="" type="checkbox"/>	<input type="checkbox"/>	<input type="checkbox"/>	<input type="checkbox"/>



Te	5	6	7	8	9	10
0	<input type="checkbox"/>	<input type="checkbox"/>	<input type="checkbox"/>	<input type="checkbox"/>	<input type="checkbox"/>	<input type="checkbox"/>
5	<input type="checkbox"/>	<input type="checkbox"/>	<input type="checkbox"/>	<input type="checkbox"/>	<input type="checkbox"/>	<input checked="" type="checkbox"/>
10	<input type="checkbox"/>	<input type="checkbox"/>	<input type="checkbox"/>	<input type="checkbox"/>	<input type="checkbox"/>	<input type="checkbox"/>
15	<input type="checkbox"/>	<input type="checkbox"/>	<input type="checkbox"/>	<input type="checkbox"/>	<input type="checkbox"/>	<input checked="" type="checkbox"/>
20	<input type="checkbox"/>	<input type="checkbox"/>	<input type="checkbox"/>	<input type="checkbox"/>	<input type="checkbox"/>	<input type="checkbox"/>
25	<input type="checkbox"/>	<input type="checkbox"/>	<input type="checkbox"/>	<input type="checkbox"/>	<input checked="" type="checkbox"/>	<input type="checkbox"/>
30	<input type="checkbox"/>	<input type="checkbox"/>	<input type="checkbox"/>	<input type="checkbox"/>	<input type="checkbox"/>	<input type="checkbox"/>
35	<input type="checkbox"/>	<input type="checkbox"/>	<input type="checkbox"/>	<input type="checkbox"/>	<input type="checkbox"/>	<input checked="" type="checkbox"/>
40	<input type="checkbox"/>	<input type="checkbox"/>	<input type="checkbox"/>	<input type="checkbox"/>	<input type="checkbox"/>	<input type="checkbox"/>
45	<input type="checkbox"/>	<input type="checkbox"/>	<input type="checkbox"/>	<input type="checkbox"/>	<input type="checkbox"/>	<input checked="" type="checkbox"/>
50	<input type="checkbox"/>	<input type="checkbox"/>	<input type="checkbox"/>	<input type="checkbox"/>	<input type="checkbox"/>	<input type="checkbox"/>
55	<input type="checkbox"/>	<input type="checkbox"/>	<input type="checkbox"/>	<input type="checkbox"/>	<input type="checkbox"/>	<input checked="" type="checkbox"/>
60	<input type="checkbox"/>	<input type="checkbox"/>	<input type="checkbox"/>	<input type="checkbox"/>	<input type="checkbox"/>	<input type="checkbox"/>
65	<input type="checkbox"/>	<input type="checkbox"/>	<input type="checkbox"/>	<input type="checkbox"/>	<input type="checkbox"/>	<input checked="" type="checkbox"/>
70	<input type="checkbox"/>	<input type="checkbox"/>	<input type="checkbox"/>	<input type="checkbox"/>	<input type="checkbox"/>	<input type="checkbox"/>
75	<input type="checkbox"/>	<input type="checkbox"/>	<input type="checkbox"/>	<input type="checkbox"/>	<input type="checkbox"/>	<input checked="" type="checkbox"/>
80	<input type="checkbox"/>	<input type="checkbox"/>	<input type="checkbox"/>	<input type="checkbox"/>	<input type="checkbox"/>	<input type="checkbox"/>
85	<input type="checkbox"/>	<input type="checkbox"/>	<input type="checkbox"/>	<input type="checkbox"/>	<input type="checkbox"/>	<input checked="" type="checkbox"/>
90	<input type="checkbox"/>	<input type="checkbox"/>	<input type="checkbox"/>	<input type="checkbox"/>	<input type="checkbox"/>	<input type="checkbox"/>
95	<input type="checkbox"/>	<input type="checkbox"/>	<input type="checkbox"/>	<input type="checkbox"/>	<input type="checkbox"/>	<input checked="" type="checkbox"/>
100	<input type="checkbox"/>	<input type="checkbox"/>	<input type="checkbox"/>	<input type="checkbox"/>	<input type="checkbox"/>	<input type="checkbox"/>

Te	5	6	7	8	9	10
110	<input type="checkbox"/>	<input type="checkbox"/>	<input type="checkbox"/>	<input type="checkbox"/>	<input type="checkbox"/>	<input checked="" type="checkbox"/>
120	<input type="checkbox"/>	<input type="checkbox"/>	<input type="checkbox"/>	<input type="checkbox"/>	<input type="checkbox"/>	<input checked="" type="checkbox"/>
130	<input type="checkbox"/>	<input type="checkbox"/>	<input type="checkbox"/>	<input type="checkbox"/>	<input type="checkbox"/>	<input checked="" type="checkbox"/>
140	<input type="checkbox"/>	<input type="checkbox"/>	<input type="checkbox"/>	<input type="checkbox"/>	<input type="checkbox"/>	<input type="checkbox"/>
150	<input type="checkbox"/>	<input type="checkbox"/>	<input type="checkbox"/>	<input type="checkbox"/>	<input type="checkbox"/>	<input checked="" type="checkbox"/>
160	<input type="checkbox"/>	<input type="checkbox"/>	<input type="checkbox"/>	<input type="checkbox"/>	<input type="checkbox"/>	<input type="checkbox"/>
170	<input type="checkbox"/>	<input type="checkbox"/>	<input type="checkbox"/>	<input type="checkbox"/>	<input type="checkbox"/>	<input checked="" type="checkbox"/>
180	<input type="checkbox"/>	<input type="checkbox"/>	<input type="checkbox"/>	<input type="checkbox"/>	<input type="checkbox"/>	<input type="checkbox"/>
190	<input type="checkbox"/>	<input type="checkbox"/>	<input type="checkbox"/>	<input type="checkbox"/>	<input type="checkbox"/>	<input checked="" type="checkbox"/>
200	<input type="checkbox"/>	<input type="checkbox"/>	<input type="checkbox"/>	<input type="checkbox"/>	<input type="checkbox"/>	<input type="checkbox"/>
225	<input type="checkbox"/>	<input type="checkbox"/>	<input type="checkbox"/>	<input type="checkbox"/>	<input type="checkbox"/>	<input checked="" type="checkbox"/>
250	<input type="checkbox"/>	<input type="checkbox"/>	<input type="checkbox"/>	<input type="checkbox"/>	<input type="checkbox"/>	<input type="checkbox"/>
275	<input type="checkbox"/>	<input type="checkbox"/>	<input type="checkbox"/>	<input type="checkbox"/>	<input type="checkbox"/>	<input checked="" type="checkbox"/>
300	<input type="checkbox"/>	<input type="checkbox"/>	<input type="checkbox"/>	<input type="checkbox"/>	<input type="checkbox"/>	<input type="checkbox"/>
325	<input type="checkbox"/>	<input type="checkbox"/>	<input type="checkbox"/>	<input type="checkbox"/>	<input type="checkbox"/>	<input checked="" type="checkbox"/>
350	<input type="checkbox"/>	<input type="checkbox"/>	<input type="checkbox"/>	<input type="checkbox"/>	<input type="checkbox"/>	<input type="checkbox"/>
375	<input type="checkbox"/>	<input type="checkbox"/>	<input type="checkbox"/>	<input type="checkbox"/>	<input type="checkbox"/>	<input checked="" type="checkbox"/>
400	<input type="checkbox"/>	<input type="checkbox"/>	<input type="checkbox"/>	<input type="checkbox"/>	<input type="checkbox"/>	<input type="checkbox"/>
425	<input type="checkbox"/>	<input type="checkbox"/>	<input type="checkbox"/>	<input type="checkbox"/>	<input type="checkbox"/>	<input checked="" type="checkbox"/>
450	<input type="checkbox"/>	<input type="checkbox"/>	<input type="checkbox"/>	<input type="checkbox"/>	<input type="checkbox"/>	<input type="checkbox"/>
475	<input type="checkbox"/>	<input type="checkbox"/>	<input type="checkbox"/>	<input type="checkbox"/>	<input type="checkbox"/>	<input checked="" type="checkbox"/>

Te	5	6	7	8	9	10
500	<input type="checkbox"/>	<input type="checkbox"/>	<input type="checkbox"/>	<input type="checkbox"/>	<input type="checkbox"/>	<input type="checkbox"/>
550	<input type="checkbox"/>	<input type="checkbox"/>	<input type="checkbox"/>	<input type="checkbox"/>	<input type="checkbox"/>	<input checked="" type="checkbox"/>
600	<input type="checkbox"/>	<input type="checkbox"/>	<input type="checkbox"/>	<input type="checkbox"/>	<input type="checkbox"/>	<input type="checkbox"/>
650	<input type="checkbox"/>	<input type="checkbox"/>	<input type="checkbox"/>	<input type="checkbox"/>	<input type="checkbox"/>	<input checked="" type="checkbox"/>
700	<input type="checkbox"/>	<input type="checkbox"/>	<input type="checkbox"/>	<input type="checkbox"/>	<input type="checkbox"/>	<input type="checkbox"/>
750	<input type="checkbox"/>	<input type="checkbox"/>	<input type="checkbox"/>	<input type="checkbox"/>	<input type="checkbox"/>	<input checked="" type="checkbox"/>
800	<input type="checkbox"/>	<input type="checkbox"/>	<input type="checkbox"/>	<input type="checkbox"/>	<input type="checkbox"/>	<input type="checkbox"/>
850	<input type="checkbox"/>	<input type="checkbox"/>	<input type="checkbox"/>	<input type="checkbox"/>	<input type="checkbox"/>	<input type="checkbox"/>
900	<input type="checkbox"/>	<input type="checkbox"/>	<input type="checkbox"/>	<input type="checkbox"/>	<input type="checkbox"/>	<input checked="" type="checkbox"/>
950	<input type="checkbox"/>	<input type="checkbox"/>	<input type="checkbox"/>	<input type="checkbox"/>	<input type="checkbox"/>	<input type="checkbox"/>
1000	<input type="checkbox"/>	<input type="checkbox"/>	<input type="checkbox"/>	<input type="checkbox"/>	<input type="checkbox"/>	<input checked="" type="checkbox"/>
1050	<input type="checkbox"/>	<input type="checkbox"/>	<input type="checkbox"/>	<input type="checkbox"/>	<input type="checkbox"/>	<input type="checkbox"/>
1100	<input type="checkbox"/>	<input type="checkbox"/>	<input type="checkbox"/>	<input type="checkbox"/>	<input type="checkbox"/>	<input checked="" type="checkbox"/>
1150	<input type="checkbox"/>	<input type="checkbox"/>	<input type="checkbox"/>	<input type="checkbox"/>	<input type="checkbox"/>	<input type="checkbox"/>
1200	<input type="checkbox"/>	<input type="checkbox"/>	<input type="checkbox"/>	<input type="checkbox"/>	<input type="checkbox"/>	<input checked="" type="checkbox"/>
1250	<input type="checkbox"/>	<input type="checkbox"/>	<input type="checkbox"/>	<input type="checkbox"/>	<input type="checkbox"/>	<input type="checkbox"/>
1300	<input type="checkbox"/>	<input type="checkbox"/>	<input type="checkbox"/>	<input type="checkbox"/>	<input type="checkbox"/>	<input checked="" type="checkbox"/>
1400	<input type="checkbox"/>	<input type="checkbox"/>	<input type="checkbox"/>	<input type="checkbox"/>	<input type="checkbox"/>	<input type="checkbox"/>
1500	<input type="checkbox"/>	<input type="checkbox"/>	<input type="checkbox"/>	<input type="checkbox"/>	<input type="checkbox"/>	<input checked="" type="checkbox"/>
1600	<input type="checkbox"/>	<input type="checkbox"/>	<input type="checkbox"/>	<input type="checkbox"/>	<input type="checkbox"/>	<input type="checkbox"/>
1700	<input type="checkbox"/>	<input type="checkbox"/>	<input type="checkbox"/>	<input type="checkbox"/>	<input type="checkbox"/>	<input checked="" type="checkbox"/>
1800	<input type="checkbox"/>	<input type="checkbox"/>	<input type="checkbox"/>	<input type="checkbox"/>	<input type="checkbox"/>	<input type="checkbox"/>

- The product has to be powered off and on again for the new selection to take effect.
- La nouvelle sélection ne prend effet qu'après un cycle hors/sous tension du produit.
- Das Produkt muss aus- und wiedereingeschaltet werden, damit die neue Auswahl übernommen wird.
- El producto se debe apagar y encender de nuevo para que la selección surta efecto.
- Per applicare la nuova selezione, il prodotto deve essere spento e riacceso.
- 需断电重启产品，新的选择才会生效。

6. LED Indication & Diagnostic / Voyants LED et diagnostic / LED-Anzeige und -Diagnose / Indicaciones LED y diagnóstico / Indicazione e diagnostica a LED / LED 指示和诊断

-  Off / Eteinte / Erloschen / Apagado / Spenta / 关闭
-  Slow Blink / Clignotement lent / Langsames Blinken / Parpadeo lento / Lampeggio lento / 慢闪
-  On / Allumée / Brennt / Encendido / Accesa / 开启
-  Fast Blink / Clignotement rapide / Schnelles Blinken / Parpadeo rápido / Lampeggio veloce / 快闪
-  Invalid Setting / Paramètre incorrect / Ungültige Einstellung / Configuración no válida / Impostazione non valida / 无效的设置

























LU Fault Upper Limit Fault / Défaute de limite supérieure / Störung Obergrenze / Fallo de límite superior / Errore limite superiore / 上限故障

LL Fault Lower Limit Fault / Défaute de limite inférieure / Störung Untergrenze / Fallo de límite inferior / Errore limite inferiore / 下限故障

SC Fault Short Circuit Fault / Défaute de court-circuit / Störung Kurzschluss / Fallo de cortocircuito / Errore corto circuito / 短路故障

LB Fault Line Break Fault / Défaute de coupure de ligne / Störung Leitungsbruch / Fallo de circuito abierto / Errore interruzione di linea / 断线故障

RMPT1UUBD / RMTc1UUBD

PWR 			Power OFF	OFF
PWR 	H 	L 	Power ON 	ON
PWR 	H 	L 	Power ON 	
PWR 	H 	L 	Power ON 	LU Fault
PWR 	H 	L 	Power ON 	LL Fault
PWR 	H 	L 	Power ON 	SC Fault[^] / LB Fault[^]

[^]Output signal can be configured via DIP switch.

[^]Le signal de sortie peut être configuré à l'aide d'un interrupteur DIP.

[^]Das Ausgangssignal kann per DIP-Schalter konfiguriert werden.

[^]La señal de salida se puede configurar mediante el interruptor DIP.

[^]Il segnale di uscita può essere configurato tramite DIP switch.

[^]输出信号可通过 DIP 开关进行配置。