

SpaceLogic Room Units

Air Quality Sensors – BACnet and Modbus



Note: A subset of models shown.

Product Description

The SpaceLogic SLP Series of air quality sensors for living space is a flexible multisensor platform for use with BAS controllers designed to accept BACnet or Modbus outputs. Housings are available in Medium matte white and Optimum faces available in black and white. All housing types are available with three user interface options: touchscreen, LCD with three buttons and blank. CO₂ and temperature sensors are included with all SLP Series air quality sensors. Models with VOC sensors and relative humidity sensors are also available.

Features

- Medium matte white housing or optimum glass panel housing available in white or black
- Field calibratable non-dispersive infrared CO₂ sensor
- Replaceable RH element available in 1% & 2% with NIST certificate
- VOC sensor available
- Temperature output on all models
- 61 mm (2.4") backlit color touchscreen and LCD, three button display options available
 - Digital temperature indication (0.1° display resolution of °F or °C)
 - Digital humidity indication (0.1% RH display resolution)
 - Digital CO₂ indication (0 to 2000 ppm display resolution)
 - Selectable temp, RH and fan speed setpoint
 - Configurable screen/button lock and display timeout
 - Override
- Selectable BACnet MSTP and Modbus outputs via RS-485
- 18-24 AWG screw terminals

Available Products Matrix

SLP	Housing	User Interface	CO ₂ Sensor	RH Sensor**	Example:
	<input type="checkbox"/>	<input type="checkbox"/>	<input type="checkbox"/>	<input type="checkbox"/>	SLP <input type="checkbox"/> <input type="checkbox"/> <input type="checkbox"/> <input type="checkbox"/>
	S = Medium white matte housing W = Optimum white housing B = Optimum black housing	T = Color touchscreen L = 3-button LCD display X = None	C = NDIR CO ₂ CV = NDIR CO ₂ / VOC	2 = 2% X = None	

** RH elements are replaceable.

Replaceable RH Elements

Model	RH Accuracy	Calibration Certificate	Description
SLXRHS1N	±1%	X	Replaceable RH sensor, 1% with NIST certification
SLXRHS2N	±2%	X	Replaceable RH sensor, 2% with NIST certification
SLXRHS2X	±2%		Replaceable RH sensor, 2%

USA: +1 888-444-1311
 Europe: +46 10 478 2000
 Asia: +65 6484 7877
www.schneider-electric.com

Life Is On



Specifications

Operating Environment			
Input power	Class 2; 20 to 30 Vdc, 24 Vac, 50 to 60 Hz		
Protocol output	BACnet or Modbus via RS-485, selectable		
Operating temp. range	0 to 50 °C (32 to 122 °F)		
Operating humidity range	0 to 95% RH non-condensing		
Housing material	High impact ABS plastic		
CO ₂ Sensor			
Sensor type	Non-dispersive infrared (NDIR), diffusion sampling		
Output range	0 to 2000 ppm		
Accuracy	±30 ppm ±3% of measured value		
Repeatability	±20 ppm ±1% of measured value		
Response time	<60 seconds for 90% step change		
VOC Sensor			
Sensor type	Solid state		
Output range	0 to 100% AQI for VOC		
Accuracy	±15% of measured value		
Output scale	0 to 1,000 ppb of total VOC (TVOC)		
AQI table*	Level	Ventilation Recommendation	TVOC (ppb)
	>61%	Greatly increased	>610
	20 to 61%	Significantly increased	200 to 610
	10 to 20%	Slightly increased	100 to 200
	5 to 10%	Average	50 to 100
	0 to 5%	Target value	0 to 50
RH Sensor			
HS sensor	Thin-film capacitive, replaceable		
Accuracy	±2% from 10 to 80% RH @ 25°C (77 °F)		
Hysteresis	1.5% typical		
Linearity	Included in accuracy specification		
Stability	±1% @ 20°C (68 °F) annually for 2 years		
Output range	0 to 100% RH		
Temperature coefficient	±0.1% RH/°C above or below 25 °C (77 °F) typical		
Temperature Sensor			
Sensor type	Solid state, integrated circuit		
Accuracy	±0.2 °C (±0.4 °F) typical		
Resolution	0.1 °C (0.1 °F)		
Range	0 to 50 °C (32 to 122 °F)		

Display Models	
Touchscreen	61 mm (2.4 in), color, backlit, capacitive, 240x300px Setpoint: Temperature, humidity or fan speed selectable Timeout override: Display timeout Lockout override: Touchscreen/button lockout
	52mm (2.05 in), segmented with 3 buttons Setpoint: Temperature, humidity or fan speed selectable Timeout override: Display timeout Lockout override: Touchscreen/button lockout
LCD	52mm (2.05 in), segmented with 3 buttons Setpoint: Temperature, humidity or fan speed selectable Timeout override: Display timeout Lockout override: Touchscreen/button lockout
Setpoints	
Temperature setpoint	Scale: 0 to 50 °C (32 to 122 °F) max., adjustable span
Humidity setpoint	Scale: 0 to 100% RH
Fan speed setpoint	Off, Low, Med., High
Wiring Terminals	
Terminal blocks	Screw terminals, 18-24 AWG
Screw terminal torque	0.2 N-m (2.0 in-lbF) max.
Regulatory Information	
	UL 916, European conformance CE: EN61000-6-2 EN61000-6-3 EN61000 Series - industrial immunity EN 61326-1 FCC Part 15 Class B, REACH, RoHS, Green Premium, RCM (Australia), ICES-003 (Canada)
Agency approvals	

* Air Quality Index for VOC aligns with TVOC levels for IAQ as specified by the WHO (World Health Organization).

Dimensions mm (in.) Optimum Housing

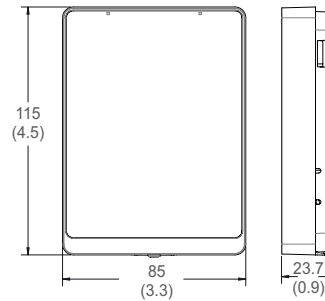

Medium Housing

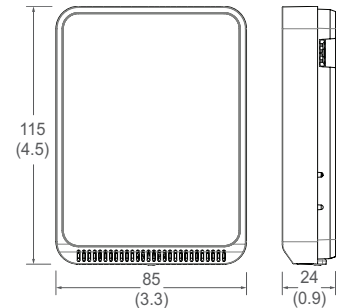

USA: +1 888-444-1311
Europe: +46 10 478 2000
Asia: +65 6484 7877
www.schneider-electric.com

Life Is On

Schneider Electric

Installation

1. Remove the cover from the base at the bottom of the device.



2. Position the sensor base vertically on the wall 1.35 m (4.5 ft.) above the floor with the “UP” arrow facing upward. Locate away from windows, vents and other sources of draft. If possible, do not mount on an external wall, as this may cause inaccurate temperature readings.



3. Pull 18 or 22 AWG cable(s) through the hole in the backplate.



4. Mount the backplate onto the wall using the screws provided.

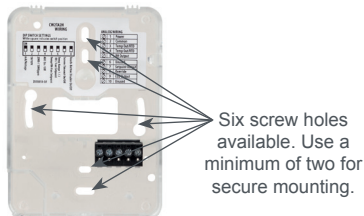

5. Connect the wires to the screw terminals. Do not over-tighten the screws.

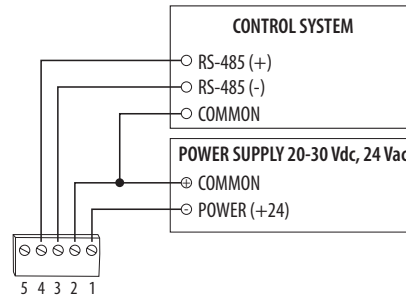

6. Configure the device.

Address Configuration:

Each device on a single network must have a unique address. Set the DIP switch labeled “ADDRESS” to assign a unique address before the device is connected to the network. If an address is selected that conflicts with another device, neither device will be able to communicate.

Address the device as any whole number between and including 1 to 127. Note that zero is not a valid address for Modbus; zero is a valid address for BACnet. Positions 1 through 7 of the “ADDRESS” DIP switch designate the address. Position 8 toggles between the Modbus and BACnet communication protocols, as shown in the diagram below. This is the left bank of DIP switches on the sensor.

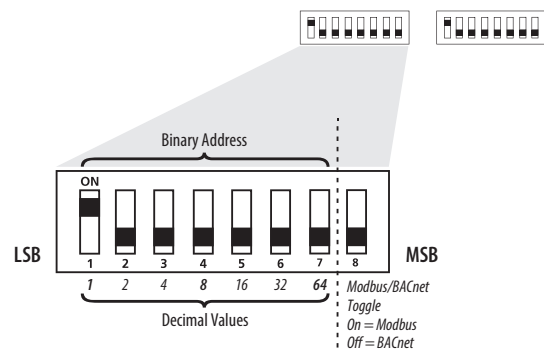

To set an address using the DIP switch, simply add the values of any switches that are in the ON position.

For example, an address of 73 is set as shown in the diagram below.

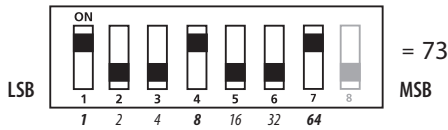

Position number 1 has an ON value of 1, position number 4 has an ON value of 8 and position number 7 has an ON value of 64 (1 + 8 + 64 = 73).

Communications Configuration:

See the Product Diagram section for the location of the DIP switch labeled “CONFIG”. The following parameters are configurable:

- Parity (Modbus only): None, Odd, None1 (one stop bit), Even
- Baud rate: 8600, 19200, 38400, 57600 (Modbus), 76800 (BACnet)
- Autobaud: On, Off

Note: Autobaud may not be able to automatically determine the baud rate in some situations. In this case, set Autobaud to OFF and use the manual baud setting.

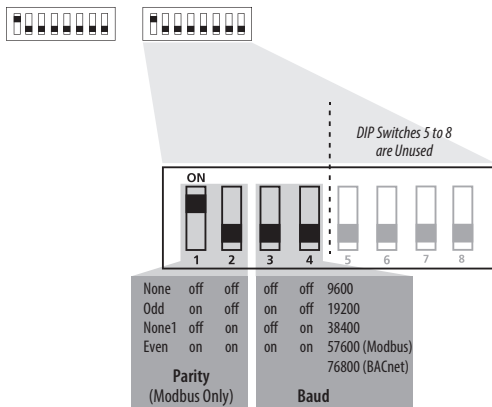

Example: No Parity, 19200 Baud, Autobaud Off:

1	2	3	4	5	6	7	8
off	off	on	off	off	off	off	off
None		19200 Baud		Unused			

Modbus Point Map

Function Codes:

Function Code	Function
03	Read holding (RW) registers
04	Read input (RO) registers
06	Write single register
16	Write multiple registers
01	Read coils
05	Write single coil
15	Write multiple coils

All of these values correspond to BACnet objects with the same name. See the BACnet Conformance Statement for their definitions.

Note that an attempt to write to “read only” holding registers will give an error and the entire write command will not be executed even if writing to read/write locations were also requested. Exception code 2 is given in this case. “Preserved” means the values is maintained through power outages.

Input Registers (Read Only):

Register	Description
1	Temperature reading in IEEE 32-bit floating point
3	Humidity reading in IEEE 32-bit floating point
5	CO ₂ reading in IEEE 32-bit floating point
7	VOC reading in 32-bit integer
9	Model
42	Serial number

Holding Registers (Read/Write):

Register	Description
1	Temperature setpoint
3	Humidity setpoint
5	Screen color set
7	Device name
40	Fan speed

Coils (Read/Write):

Register	Description
1	CO ₂ stoplight
2	Touch button disable
3	Invoke CO ₂ calibration
4	Temperature (°C)
5	Occupancy override
6	Touch timeout
7	Display shows humidity
8	Display shows CO ₂ level
9	Display shows VOC level

BACnet Descriptions

Note: In the tables below, all properties are read-only unless otherwise noted. "Preserved" means the value is maintained through power outages.

Present_Value Range Restrictions:

Object Name	Minimum Value	Maximum Value
DEV - Object_Name	1 Character	65 Characters
Temperature Setpoint	Min_Pres_Value 15	Max_Pres_Value Max_Pres_Value -1
Min_Pres_Value Max_Pres_Value	Min_Pres_Value +1	30
Humidity Setpoint	Min_Pres_Value 30	Max_Pres_Value Max_Pres_Value -1
Min_Pres_Value Max_Pres_Value	Min_Pres_Value +1	85
Screen Color Set Fan Speed	1	4

Standard Object Types Supported:

Object Type	Supported Optional Properties	Writable Properties
Analog Input - AI	Reliability	None
Analog Value - AV	Min_Pres_Value Max_Pres_Value	Min_Pres_Value Max_Pres_Value Present_Value
Binary Value - BV	None	Present Value
Multistate Value - MSV	None	Present Value
Device - DEV	Max Info Frames Max_Master	APDU_Timeout Max_Master Object_Name

Objects Table:

Object Name	Object Identifier	Object Property
Room Temperature	AI 1	Temperature in Room
Room Humidity	AI 2	Humidity in Room
CO ₂ Sensor	AI 3	CO ₂ Concentration
VOC Sensor	AI 4	VOC Level
Temperature Setpoint	AV 1	Setpoint Value for Temperature
Humidity Setpoint	AV2	Setpoint Value for Humidity
CO ₂ Stoplight	BV 1	ACTIVE enables CO ₂ Stoplight INACTIVE disables CO ₂ Stoplight
Touch Disable	BV2	ACTIVE disables Touch Response INACTIVE enables Touch Response
CO ₂ ABC Cal	BV3	ACTIVE enables ABC Calibration INACTIVE disables ABC Calibration
Temperature Units	BV4	ACTIVE displays temperature in Fahrenheit INACTIVE displays temperature in Celsius
Occupancy Override	BV5	ACTIVE means room is not occupied INACTIVE means room is occupied
Screen Timeout	BV 6	ACTIVE enables Screen Timeout INACTIVE disables Screen Timeout
Display Humidity	BV7	ACTIVE displays humidity on Screen INACTIVE removes humidity from Screen
Display CO ₂	BV8	ACTIVE displays CO ₂ level on Screen INACTIVE removes CO ₂ level from Screen
Display VOC	BV9	ACTIVE displays VOC level on Screen INACTIVE removes VOC level from Screen
Screen Color Set	MSV 1	Selection for Screen Color Theme
Fan Speed	MSV 2	Fan Speed Selection

Device Objects Table:

Object Name	Object Identifier	Object Property	Descrip.
Living Space Room Unit XXXXXXX	Object_Device: nnn	Object_Identifier (Read only)	Unique value where nnn is the MS/TP address.

BACnet Protocol Implementation Conformance Statement

- Vendor Name: Schneider Electric
 - Product Name: Living Space Room Unit
 - Product Model: SLPXXXX
 - Application Software Version: LSA_APP_REV0.xx.xx
 - Firmware Revision: LSA_APP_REV0.xx.xx
 - BACnet Protocol Version : 1
 - BACnet Protocol Revision: 16
 - Product Description: Environmental Sensor
 - BACnet Standardized Device Profile (AnnexL):
 - BACnet Application Specific Controller (B-ASC)
 - List All BACnet Interoperatvility Building Blocks Support-ed(Annex K):
 - DS-RP-B, DS-WP-B, DM-DDB-B, DM-DOB-B, DM-DCC-B
 - Data Link Layer Options: MS/TP (Clause 9), baud rates, 9600, 19200, 38400, 76800
 - Device Address Binding: Static Device binding is not supported.
 - Networking Options: None
 - Character Sets supported: ISO 10646 (UTF-8)
7. With sensor base fully installed, align top of cover to mounting tabs on top of sensor base. Swing cover downward until it latches at the bottom.



8. Install locking screw to secure cover in closed position.



Touchscreen Operation
Main Screen

The touchscreen user interface displays applicable sensor output values (temperature, RH, CO₂ and VOC), setpoint value, menu button and CO₂ stoplight status (if enabled).

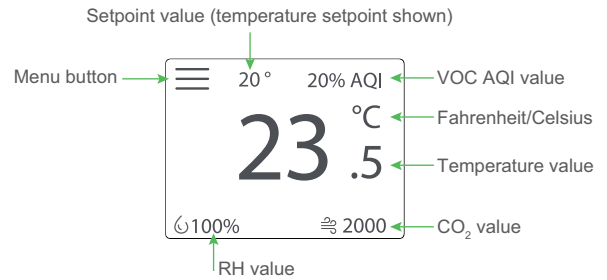

Menu Screen

The menu screen opens when pressing the Menu button on the main screen. Integrator’s submenu, occupancy/override, Fahrenheit/Celsius, settings, setpoint submenu (temp, RH and fan) and CO₂ stoplight buttons are displayed on the menu screen.





Note: RH setpoint will not appear on non-RH models.

Menu Button Functions

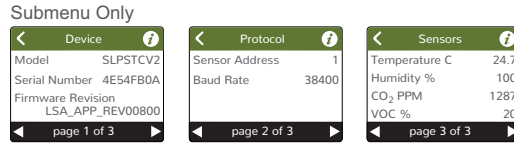

 **Integrator's Submenu**
Press this icon to access the Integrator's menu.



 **Occupied Override Button**
Press this icon to provide momentary ground output to the controller

Single Press Only
 Signals occupied/override call to controller.

 **Fahrenheit/Celsius Switch**
Press this icon to display either °C or °F.

Single Press Only
 Changes units to Fahrenheit when pressed.
 Changes units to Celsius when pressed.

 **Settings**
This icon provides the ability to change the color scheme of the display.

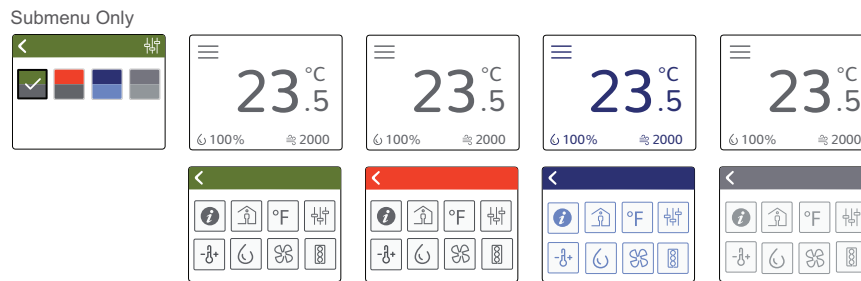

 **Temp Setpoint Adjustment**
Click this icon to access the setpoint change menu.

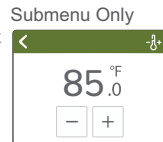

 **Humidity Setpoint Adjustment**
Click this icon to access the setpoint change menu.

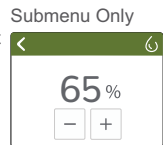

 **Fan Speed**
Click this icon to access the fan speed menu.

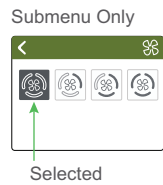

 **CO₂ Stoplight Menu**
Click this icon to toggle the CO₂ Stoplight feature on and off. With CO₂ Stoplight turned on, the background color of the main screen changes with CO₂ level. This provides a visual indicator of CO₂ levels to the room occupants.

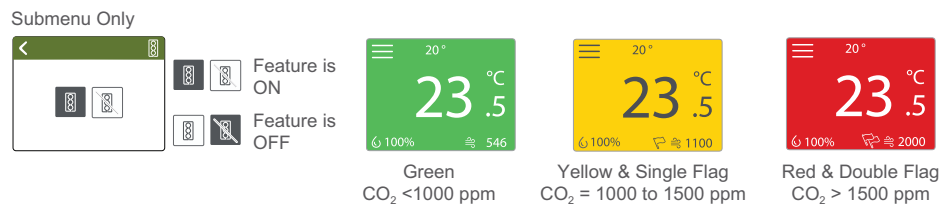

China RoHS Compliance Information
Environment-Friendly Use Period (EFUP) Table

部件名称	有害物质 - Hazardous Substances					
Part Name	铅 (Pb)	汞 (Hg)	镉 (Cd)	六价铬 (Cr (VI))	多溴联苯 (PBB)	多溴二苯醚 (PBDE)
电子件 Electronic	X	O	O	O	O	O

本表格依据SJ/T11364的规定编制。

O: 表示该有害物质在该部件所有均质材料中的含量均在 GB/T 26572规定的限量要求以下。

X: 表示该有害物质至少在该部件的某一均质材料中的含量超出 GB/T 26572规定的限量要求。

(企业可在此处，根据实际情况对上表中打“X”的技术原因进行进一步说明。)

This table is made according to SJ/T 11364.

O: indicates that the concentration of hazardous substance in all of the homogeneous materials for this part is below the limit as stipulated in GB/T 26572.

X: indicates that concentration of hazardous substance in at least one of the homogeneous materials used for this part is above the limit as stipulated in GB/T 26572

Z000057-0B