

Advantys STB

Standard Fipio Network Interface Module Applications Guide

8/2009

Schneider Electric assumes no responsibility for any errors that may appear in this document. If you have any suggestions for improvements or amendments or have found errors in this publication, please notify us.

No part of this document may be reproduced in any form or by any means, electronic or mechanical, including photocopying, without express written permission of Schneider Electric.

All pertinent state, regional, and local safety regulations must be observed when installing and using this product. For reasons of safety and to help ensure compliance with documented system data, only the manufacturer should perform repairs to components.

When devices are used for applications with technical safety requirements, the relevant instructions must be followed.

Failure to use Schneider Electric software or approved software with our hardware products may result in injury, harm, or improper operating results.

Failure to observe this information can result in injury or equipment damage.

© 2009 Schneider Electric. All rights reserved.

Table of Contents



	Safety Information	5
	About the Book	7
Chapter 1	Introduction	11
	What Is a Network Interface Module?	12
	What Is Advantys STB?	15
	About Fipio	19
	Fipio Networks and Communications	21
	Specifications and Limitations	23
Chapter 2	The STB NFP 2212 NIM	25
	External Features of the STB NFP 2212	26
	STB NFP Fieldbus Interface	28
	Rotary Switches: Setting the Network Node Address	30
	LED Indicators	33
	Advantys STB Island Status LEDs	35
	The CFG Interface	38
	The Power Supply Interface	41
	Logic Power	43
	Selecting a Source Power Supply for the Island's Logic Power Bus.	45
	Module Specifications	48
Chapter 3	How to Configure the Island	51
	How Do Modules Automatically Get Island Bus Addresses?	52
	How to Auto-Configure Default Parameters for Island Modules	54
	How to Install the STB XMP 4440 Optional Removable Memory Card. . .	55
	Using the STB XMP 4440 Optional Removable Memory Card to Configure the Island	58
	What is the RST Button?	61
	How to Overwrite Flash Memory with the RST Button	62
Chapter 4	Fieldbus Communications Support	65
4.1	Before You Begin	66
	Standard Profiles	67
	FRD Profile	70
	FSD Profile	71

	FED Profile	73
	Network Cycle Time	74
	About Class 1 Devices	75
	Applications and Network Management Services	77
4.2	Data Exchange	80
	Data Exchange	81
	Standard Diagnostic Data	85
	Fipio Specific Channel Status Data	87
4.3	Fipio Application Example	92
	Physical Network	93
	Configuring the Premium TSX P 57453 Using PL7 PRO	95
Chapter 5	Advanced Configuration Features	105
	STB NFP 2212 Configurable Parameters	106
	Configuring Mandatory Modules	110
	Prioritizing a Module	112
	What Is a Reflex Action?	113
	Island Fallback Scenarios	117
	Saving Configuration Data	119
	Write-Protecting Configuration Data	120
	A Modbus View of the Island's Data Image	121
	Predefined Diagnostics Registers in the Data Image	124
	The Island's Process Image Blocks	133
	An Example of a Modbus View of the Process Image	135
	The HMI Blocks in the Island Data Image	143
	Test Mode	145
	Run-Time Parameters	147
	Virtual Placeholder	152
Glossary	155
Index	179

Safety Information

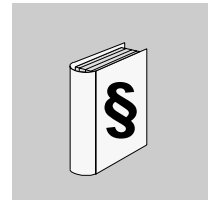

Important Information

NOTICE

Read these instructions carefully, and look at the equipment to become familiar with the device before trying to install, operate, or maintain it. The following special messages may appear throughout this documentation or on the equipment to warn of potential hazards or to call attention to information that clarifies or simplifies a procedure.



The addition of this symbol to a Danger or Warning safety label indicates that an electrical hazard exists, which will result in personal injury if the instructions are not followed.



This is the safety alert symbol. It is used to alert you to potential personal injury hazards. Obey all safety messages that follow this symbol to avoid possible injury or death.

DANGER

DANGER indicates an imminently hazardous situation which, if not avoided, **will result in** death or serious injury.

WARNING

WARNING indicates a potentially hazardous situation which, if not avoided, **can result in** death or serious injury.

 **CAUTION**

CAUTION indicates a potentially hazardous situation which, if not avoided, **can result in** minor or moderate injury.

CAUTION

CAUTION, used without the safety alert symbol, indicates a potentially hazardous situation which, if not avoided, **can result in** equipment damage.

PLEASE NOTE

Electrical equipment should be installed, operated, serviced, and maintained only by qualified personnel. No responsibility is assumed by Schneider Electric for any consequences arising out of the use of this material.

A qualified person is one who has skills and knowledge related to the construction and operation of electrical equipment and the installation, and has received safety training to recognize and avoid the hazards involved.

About the Book

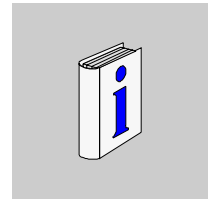

At a Glance

Document Scope

This *Guide* describes the hardware and software features of the Advantys STB NFP 2212, which is the Advantys STB standard interface to a Fipio network.

The Fieldbus Interface Protocol (Fip) is an open fieldbus standard and protocol that conforms to the FIP/World FIP standard EN 50170, Vol. 3. Fipio is designed to support and integrate a wide range of industrial peripherals.

Fipio is marketed by Schneider Automation, and used with TSX Premium, Series 7 PLCs. When an Advantys STB system is configured as a node on a Fipio network, it uses Fipio's process control capabilities to manage data exchange to and from the island.

The following information appears in this guide:

- the NIM's role as the Advantys STB gateway to a fieldbus network
- the NIM's integrated power supply and its role in the distribution of logic power across the island bus
- common external interfaces:
 - the two-receptacle connector to an external, SELV-rated power supply
 - RS-232 interface to optional devices, including the Advantys configuration software and a human-machine interface (HMI) operator panel
- Fipio specific features, including the STB NFP 2212's interface to the Fipio network and how to establish communications between an Advantys STB island bus and the upstream Fipio fieldbus master
- Fipio standard profiles and class 1 features
- the applicable Fipio and ISO OSI reference model standards
- island bus configuration options, such as default settings, I/O module current load requirements, the auto-configuration process, and custom configuration options
- the removable memory card option
- advanced configuration features, such as island bus fallback scenarios

Who Should Use This Manual?

This manual is intended to support the customer who has installed the Advantys STB island bus on a Fipio network and needs to understand the communications and connections between the STB NFP 2212 and:

- a Fipio fieldbus master
- the devices connecting to it locally—the Advantys configuration software, the HMI panel, the removable memory card
- other island modules

This manual assumes familiarity with the Fipio protocol.

Validity Note

This document is valid for Advantys 4.5 or later.

Related Documents

Title of Documentation	Reference Number
Advantys STB Analog I/O Modules Reference Guide	31007715 (E), 31007716 (F), 31007717 (G), 31007718 (S), 31007719 (I)
Advantys STB Digital I/O Modules Reference Guide	31007720 (E), 31007721 (F), 31007722 (G), 31007723 (S), 31007724 (I)
Advantys STB Counter Modules Reference Guide	31007725 (E), 31007726 (F), 31007727 (G), 31007728 (S), 31007729 (I)
Advantys STB Special Modules Reference Guide	31007730 (E), 31007731 (F), 31007732 (G), 31007733 (S), 31007734 (I)
Advantys STB System Planning and Installation Guide	31002947 (E), 31002948 (F), 31002949 (G), 31002950 (S), 31002951 (I)

Advantys STB Configuration Software Quick Start User Guide	31002962 (E), 31002963 (F), 31002964 (G), 31002965 (S), 31002966 (I)
Advantys STB Reflex Actions Reference Guide	31004635 (E), 31004636 (F), 31004637 (G), 31004638 (S), 31004639 (I)
PL7 Communications Applications Series	TLXDSCOMPLxx

You can download these technical publications and other technical information from our website at www.schneider-electric.com.

User Comments

We welcome your comments about this document. You can reach us by e-mail at techcomm@schneider-electric.com.

Introduction



Introduction

This chapter introduces the STB NFP 2212 standard network interface module in the context of its role as the gateway between a Fipio fieldbus and an STB island bus. It includes an overview of an Advantys STB island bus and concludes with an introduction to the Fipio protocol. Fipio communications services to an island bus via the NIM are highlighted.

What's in this Chapter?

This chapter contains the following topics:

Topic	Page
What Is a Network Interface Module?	12
What Is Advantys STB?	15
About Fipio	19
Fipio Networks and Communications	21
Specifications and Limitations	23

What Is a Network Interface Module?

Purpose

Every island requires a network interface module (NIM) in the leftmost location of the primary segment. Physically, the NIM is the first (leftmost) module on the island bus. Functionally, it is the gateway to the island bus. That is, all communications to and from the island bus pass through the NIM. The NIM also has an integrated power supply that provides logic power to the island modules.

The Fieldbus Network

An island bus is a node of distributed I/O on an open fieldbus network, and the NIM is the island's interface to that network. The NIM supports data transfers over the fieldbus network between the island and the fieldbus master.

The physical design of the NIM makes it compatible with both an Advantys STB island and your specific fieldbus master. Whereas the fieldbus connector on each NIM type may differ, the location on the module front panel is essentially the same.

Communications Roles

Communications capabilities provided on a standard NIM include:

Function	Role
data exchange	The NIM manages the exchange of input and output data between the island and the fieldbus master. Input data, stored in native island bus format, is converted to a fieldbus-specific format that can be read by the fieldbus master. Output data written to the NIM by the master is sent across the island bus to update the output modules and is automatically reformatted.
configuration services	Custom services can be performed by the Advantys configuration software. These services include changing the operating parameters of the I/O modules, fine-tuning island bus performance, and configuring reflex actions. The Advantys Configuration Software runs on a computer attached to the NIM's CFG interface (<i>see page 38</i>). (For NIMs with Ethernet port connectivity, you can also connect to the Ethernet port.)
human-machine interface (HMI) operations	A serial Modbus HMI panel can be configured as an input and/or output device on the island. As an input device, it can write data that can be received by the fieldbus master; as an output device, it can receive updated data from the fieldbus master. The HMI can also monitor island status, data, and diagnostic information. The HMI panel must be attached to the NIM's CFG port.

Integrated Power Supply

The NIM's built-in 24-to-5 VDC power supply provides logic power to the I/O modules on the primary segment of the island bus. The power supply requires a 24 VDC external power source. It converts the 24 VDC to 5 V of logic power for the island. Individual STB I/O modules in an island segment generally draw a logic bus current of between 50 and 265 mA. (Consult the *Advantys STB System Planning and Installation Guide* for current limitations at various operating temperatures.) If the logic bus current drawn by the I/O modules totals more than 1.2 A, additional STB power supplies need to be installed to support the load.

The NIM delivers the logic power signal to the primary segment only. Special STB XBE 1300 beginning-of-segment (BOS) modules, located in the first slot of each extension segment, have their own built-in power supplies, which provide logic power to the STB I/O modules in the extension segments. Each BOS module that you install requires 24 VDC from an external power supply.

Structural Overview

The following figure illustrates the multiple roles of the NIM. The figure provides a network view and a physical representation of the island bus:

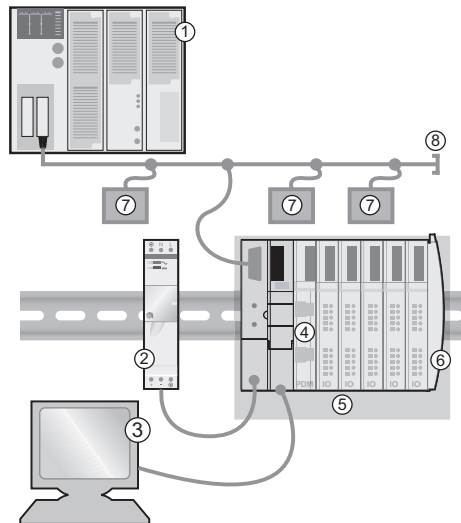

- 1 fieldbus master
- 2 external 24 VDC power supply, the source for logic power on the island
- 3 external device connected to the CFG port (a computer running the Advantys Configuration Software or an HMI panel)
- 4 power distribution module (PDM): provides field power to the I/O modules
- 5 island node
- 6 island bus terminator plate
- 7 other nodes on the fieldbus network

8 fieldbus network terminator (if required)

What Is Advantys STB?

Introduction

Advantys STB is an assembly of distributed I/O, power, and other modules that function together as an island node on an open fieldbus network. Advantys STB delivers a highly modular and versatile slice I/O solution for the manufacturing and process industries.

Advantys STB lets you design an island of distributed I/O where the I/O modules can be installed as close as possible to the mechanical field devices that they control. This integrated concept is known as *mechatronics*.

Island Bus I/O

An Advantys STB island can support as many as 32 I/O modules. These modules may be Advantys STB I/O modules, preferred modules, and enhanced CANopen devices.

The Primary Segment

STB I/O modules on an island may be interconnected in groups called segments.

Every island has at least one segment, called the *primary segment*. It is always the first segment on the island bus. The NIM is the first module in the primary segment. The primary segment must contain at least one Advantys STB I/O module and can support a logic bus current of up to 1.2 A. The segment also contains one or more power distribution modules (PDMs), which distribute field power to the I/O modules.

Extension Segments

When you are using a standard NIM, Advantys STB I/O modules that do not reside in the primary segment can be installed in *extension segments*. Extension segments are optional segments that enable an island to be a truly distributed I/O system. The island bus can support as many as six extension segments.

Special extension modules and extension cables are used to connect segments in a series. The extension modules are:

- STB XBE 1100 EOS module: the last module in a segment if the island bus is extended
- STB XBE 1300 BOS module: the first module in an extension segment

The BOS module has a built-in 24-to-5 VDC power supply similar to the NIM. The BOS power supply also provides logic power to the STB I/O modules in an extension segment.

Extension modules are connected by lengths of STB XCA 100x cable that extend the island communication bus from the previous segment to the next BOS module:

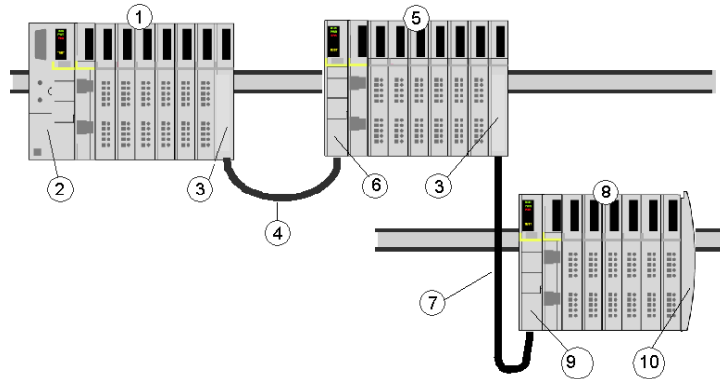

- 1 primary segment
- 2 NIM
- 3 STB XBE 1100 EOS bus extension module(s)
- 4 1 m length STB XCA 1002 bus extension cable
- 5 first extension segment
- 6 STB XBE 1300 BOS bus extension module for the first extension segment
- 7 4.5 m length STB XCA 1003 bus extension cable
- 8 second extension segment
- 9 STB XBE 1300 BOS bus extension module for the second extension segment
- 10 STB XMP 1100 termination plate

Bus extension cables are available in various lengths, ranging from 0.3 m (1 ft) to 14.0 m (45.9 ft).

Preferred Modules

An island bus can also support those auto-addressable modules referred to as *preferred modules*. Preferred modules do not mount in segments, but they do count as part of the 32-module maximum system limit.

A preferred module can connect to an island bus segment through an STB XBE 1100 EOS module and a length of STB XCA 100x bus extension cable. Each preferred module has two IEEE 1394-style cable connectors, one to receive the island bus signals and the other to transmit them to the next module in the series. Preferred modules are also equipped with termination, which must be enabled if a preferred module is the last device on the island bus and must be disabled if other modules follow the preferred device on the island bus.

Preferred modules can be chained to one another in a series, or they can connect to Advantys STB segments. As shown in the following figure, a preferred module passes the island bus communications signal from the primary segment to an extension segment of Advantys STB I/O modules:

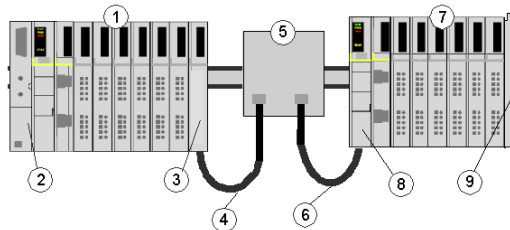

- 1 primary segment
- 2 NIM
- 3 STB XBE 1100 EOS bus extension module
- 4 1 m length STB XCA 1002 bus extension cable
- 5 preferred module
- 6 1 m length STB XCA 1002 bus extension cable
- 7 extension segment of Advantys STB I/O modules
- 8 STB XBE 1300 BOS bus extension module for the extension segment
- 9 STB XMP 1100 termination plate

Enhanced CANopen Devices

You may also install one or more enhanced CANopen devices on an island. These devices are not auto-addressable, and they must be installed at the end of the island bus. If you want to install enhanced CANopen devices on an island, you need to use an STB XBE 2100 CANopen extension module as the last module in the last segment.

NOTE: If you want to include enhanced CANopen devices in your island, you need to configure the island using the Advantys Configuration Software, and you need to configure the island to operate at 500 kbaud.

Because enhanced CANopen devices cannot be auto-addressed on the island bus, they must be addressed using physical addressing mechanisms on the devices. The enhanced CANopen devices together with the CANopen extension module form a sub-network on the island bus that needs to be separately terminated at the beginning and end. A terminator resistor is included in the STB XBE 2100 CANopen extension module for one end of the extension sub-network; the last device on the CANopen extension must also be terminated with a 120 Ω resistor. The rest of the island bus needs to be terminated after the CANopen extension module with an STB XMP 1100 termination plate:

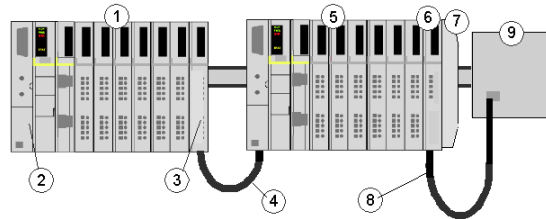

- 1 primary segment
- 2 NIM
- 3 STB XBE 1100 EOS bus extension module
- 4 1 m length STB XCA 1002 bus extension cable
- 5 extension segment
- 6 STB XBE 2100 CANopen extension module
- 7 STB XMP 1100 termination plate
- 8 typical CANopen cable
- 9 enhanced CANopen device with 120 Ω termination

Length of the Island Bus

The maximum length of an island bus (the maximum distance between the NIM and the last device on the island) is 15 m (49.2 ft). This length must take into account the extension cables between segments, extension cables between preferred modules, and the space consumed by the devices themselves.

About Fipio

Introduction

Fieldbus Interface Protocol (FIP) is an open fieldbus standard and protocol that conforms to the FIP/WorldFIP standard and, at the physical layer, to the IEC 61158-2 standard. Fipio is classified as a WorldFIP, profile 2 protocol, which means that its functionality comprises low-level configuration, parameterization, cyclical data exchange, diagnostics, and the possibility of non-cyclical exchanges. Fipio is designed to support and integrate a wide range of industrial peripherals.

Global Identifiers

Instead of physical addresses, Fipio communications rely on a system of global addresses called identifiers (global_IDs). An identifier is a 16-bit integer that uniquely identifies a device's location on a network. Because an identifier symbolizes a device's address, neither the device owning a specific identifier nor the device(s) receiving data from an identifier need know one another's physical location.

Communications Architecture

The Fipio protocol defines functionality for layers 1, 2, and 7 in the ISO OSI reference model (standard ISO 7498). The functionality of these layers is fully compliant with standard EN 50170, Volume 3. A vertical layer for network management services is added to the architecture.

A visual representation of the communication layers used in a Fipio environment might look something like the following figure:

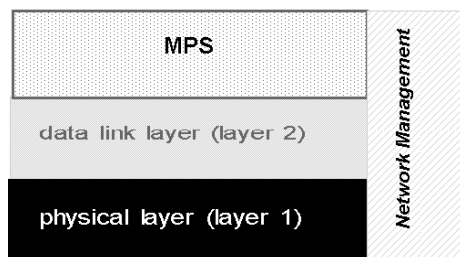

- 1 The physical layer is electrical twisted-pair cable.
- 2 Identifiers are exchanged via the data link layer.
- 3 MPS—The principal message and periodic services provided are reading and writing data.
- 4 Network management—Every Fipio bus arbitrator, i.e., master, must perform a suite of network management services.

About the Standard Profiles

Fipio requires every device on its network to conform to a standard profile (STD_P), as defined in the *WorldFip Fipio Standard Profiles—Reference Manual* (FCP DM FSDP V10E). Information about the Fipio standard profiles can also be found in the *FIP I/O Standard Device Library "SDK_FIPIU"—User's Manual*.

An Advantys STB NIM can conform to any of the following three profiles. The STB NFP 2212 will automatically select the correct profile for the island based on the configuration data size resulting from the auto-addressing (*see page 52*) and auto-configuration (*see page 54*) routines:

- FRD (*see page 70*)—Fipio reduced device
- FSD (*see page 71*)—Fipio standard device
- FED (*see page 73*)—Fipio extended device

NOTE: You can also use the Advantys configuration software to set up a standard profile type for your island. Except if it is too small (*see page 67*), a standard profile configured with the Advantys configuration software will override a profile chosen on the basis of the auto-addressing and auto-configuration data.

Class Type

In addition to conforming to a standard profile, a device on a Fipio network must conform to one of three class types. Every type of STD_P supports all three classes.

The STB NFP 2212 is a class 1 (*see page 75*) device. Class 1 devices control process to force the behavior of output data to depend on the operating modes of the fieldbus master. Unlike a class 0 device, a class 1 device can be set to different operating states; unlike a class 2 device, a class 1 device does not require parameterization.

Bus Arbitrators and Agents

Fipio uses the following terminology to refer to master and slave devices:

- bus arbitrator—fieldbus master
- agent—slave

The STB NFP 2212 is an agent device.

Fipio Networks and Communications

Introduction

On a Fipio network, every device (node) is associated with a unique identifier that is its global address.

Topologies

The topology of a Fipio network can support any one of the following configurations:

- daisy chain—each device is simply connected to the previous device via the trunk cable
- tap junction—using a tap junction, each device is connected via a tap from the trunk cable
- mixed—some network devices are daisy-chained and some are connected via taps

Producer-Consumer Model

As a time-critical protocol, Fipio networks frequently use a producer-consumer communications model.

The producer-consumer communications model is structured so there is only one producer of a variable (identifier). All of the other devices on the network are potential consumers of the variable. In actuality, one, some, or all of the other network devices may "consume" a variable.

Upon request from the Fipio fieldbus master, the producer of a variable advertises its value. Those consumers requiring the value capture it. No acknowledgment by the consumer device(s) is required.

The following table summarizes the producer-consumer communications process:

Stage	Action
1	The fieldbus master broadcasts a request for a specific identifier.
2	The owner of the identifier responds by broadcasting its value.
3	Devices requiring the data associated with the identifier recognize it.
4	The consumer devices acquire the data.

Note: Typically, a producer-consumer communications environment is a non-acknowledgment environment. This means that consumers do not routinely acknowledge the successful receipt of data from a producer. Only if an error occurs (e.g., a time out), does the consumer generate a message. If no error message is generated, the assumption is that the consumers receive and acquire the data that they need.

Required Communications Services

As a Fipio *agent* engaged in process control, the STB NFP 2212 must provide the following set of services to the island bus node:

- download FIP identifiers to a device
- remote reading of the identifiers associated with the device (re-reading configurations)
- remote control of device (total or partial reset of communication function)
- access to communication diagnostic data generated by the device (report)
- detecting presence/absence of devices required by a specific application
- device identification
- list of all devices present

NOTE: The principal management role that the STB NFP 2212 performs in an Advantys STB system is to function as a gateway to the I/O modules.

Specifications and Limitations

Introduction

The following information describes the specifications and limitations of the Fipio protocol as they apply to an Advantys STB island bus.

Fipio Network Specifications

Feature	Description
electrical interface (see page 28)	shielded twisted pair cable (150 Ω impedance); 9-pin D-SUB female connector
transmission rate	1 Mbit/s
topology	daisy chain, tap junction (multi-drop), or mixed
maximum number of nodes	128
maximum distance	1 km for a single fieldbus segment
	15 km with repeaters between segments
addressing (see page 30)	range 1 ... 127 (except 63); address is selected with the rotary switch
standards	IEC 60870-5, IEC 61158-2
	IEEE-P1451.2
	EN 50170 Vol. 3, Parts 1-3, 2-3, 3-3, 5-3, 6-3, and 7-3

STB NFP 2212 Limitations

Feature	Description
maximum input data	32 words
maximum output data	32 words
maximum number of Advantys STB modules supported	32
message handling	not available
bus arbitration	not available

The STB NFP 2212 NIM

2

Introduction

This chapter describes the external features, connections, power requirements, and the product specification for the STB NFP 2212.

What's in this Chapter?

This chapter contains the following topics:

Topic	Page
External Features of the STB NFP 2212	26
STB NFP Fieldbus Interface	28
Rotary Switches: Setting the Network Node Address	30
LED Indicators	33
Advantys STB Island Status LEDs	35
The CFG Interface	38
The Power Supply Interface	41
Logic Power	43
Selecting a Source Power Supply for the Island's Logic Power Bus	45
Module Specifications	48

External Features of the STB NFP 2212

Summary of Features

The following figure indicates where the physical features critical to STB NFP 2212 NIM operations are located:

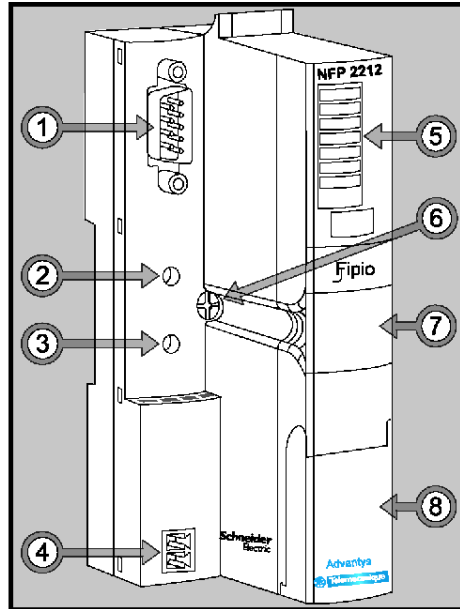

The physical features are described briefly in the following table:

Feature	Function
1 fieldbus interface	A nine-pin receptacle SUB-D connector (<i>see page 28</i>) is used to connect the NIM and the island bus to a Fipio network.
2 upper rotary switch	The two switches (<i>see page 30</i>) are used together to specify the island's node ID on the Fipio network.
3 lower rotary switch	
4 power supply interface	A two-pin receptacle connector (<i>see page 41</i>) for connecting an external 24 VDC power supply (<i>see page 45</i>) to the NIM.
5 LED array	Colored LEDs (<i>see page 33</i>) that use various patterns to visually indicate the operational status of the island bus, and the status of communications from the fieldbus master to the island bus.

Feature		Function
6	release screw	A mechanism used to remove the NIM from the DIN rail. (See the <i>Advantys STB System Planning and Installation Guide</i> 890 USE 171 00 for details.)
7	removable memory card drawer	A plastic drawer in which a removable memory card (see <i>page 55</i>) can be seated and then inserted into the NIM.
8	CFG port cover	A hinged flap on the NIM's front panel that covers the CFG interface (see <i>page 38</i>) and the RST button (see <i>page 61</i>).

Housing Shape

The L-shaped design of NIM's external housing accommodates the attachment of a fieldbus connector without raising the depth profile of the island:

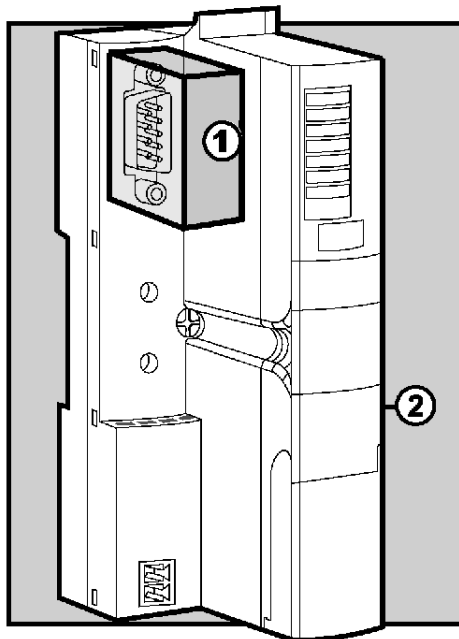

- 1 space reserved for the network connector
- 2 NIM housing

STB NFP Fieldbus Interface

Summary

The fieldbus interface on the STB NFP 2212 is the point of connection between an Advantys STB island bus and the Fipio network. The interface is a nine-pin SUB-D (male) connector.

Fieldbus Port Connections

The fieldbus interface is located on the front of the Fipio NIM at the top:

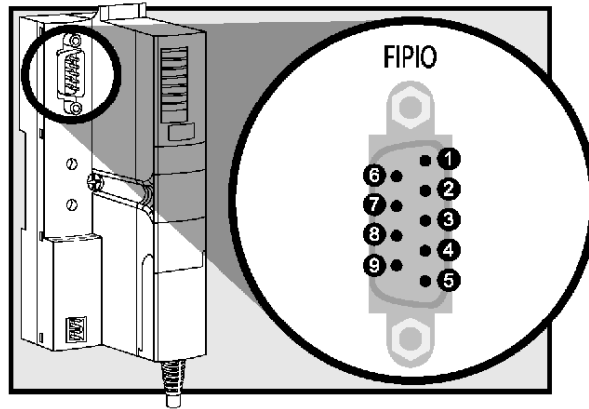

It is recommended that you use a 9-pin SUB-D (male) connector compliant with FIP standard EN 50170, Part 2, 3. The pin-out must comply with the information in the following table:

Pin	Description
1	not used
2	not used
3	not used
4	not used
5	not used
6	data+
7	data-
8	not used
9	not used

Fipio Networking Cable

The Fipio networking cable is a shielded, twisted-pair electrical cable that is compliant with Fipio standard EN 50170, Part(s) 2, 3. The cable shielding consists of an inner copper foil shielding and an outer braided layer. The cable shielding and the connection accessories must be connected to the common ground.

Connectors

Depending on where the island bus node is positioned on the Fipio network, you will need to attach either an inline or a terminated end connector to the fieldbus cable.

The connector used with the cable must be a nine-pin (female) SUB-D connector, such as the following two:

- TSXFPACC12, 45 ° built-in Fipio link
- TSXFPACC2, 90 °

Accessories

Use the information in the following table to identify the STB NFP 2212 module and the Fipio accessories that are compatible with your installation:

Description	Part No.
NIM, including the Advantys STB terminator plate	STB NFP 2212
Fipio networking cable, by the meter (or foot)	
shielded twisted pair; characteristic impedance is Ω 150	The following cables are compatible with the Advantys STB island bus: <ul style="list-style-type: none"> ● TSX FP CA e00 ● TSX FP CR e00 ● TSX FP CC e00
Connectors	
optional resistor terminator kit ¹	TSKFPACC7
inline connectors ²	The following inline connectors are compatible with the Advantys STB island bus: <ul style="list-style-type: none"> ● nine-pin TSX FP ACC 12, 45 ° connector kit ● nine-pin TSX FPA CC2, 90 ° connector kit
1 Use a terminated end connector only if the island is the last node on the Fipio network.	
2 Use an inline connector if the island is located at a Fipio network address other than the last.	

Rotary Switches: Setting the Network Node Address

Summary

The island is a single node on the Fipio network, and it requires a network address. The address can be any numeric from 1 to 127 that is unique with respect to the other node addresses on the same network. The node address is set with a pair of rotary switches on the NIM.

The fieldbus master and the NIM can communicate over the Fipio network only while the rotary switches are set to a valid node address.

Physical Description

The two rotary switches are positioned one above the other on the front of the STB NFP 2212. The upper switch represents the tens digit and the lower switch represents the ones digit:

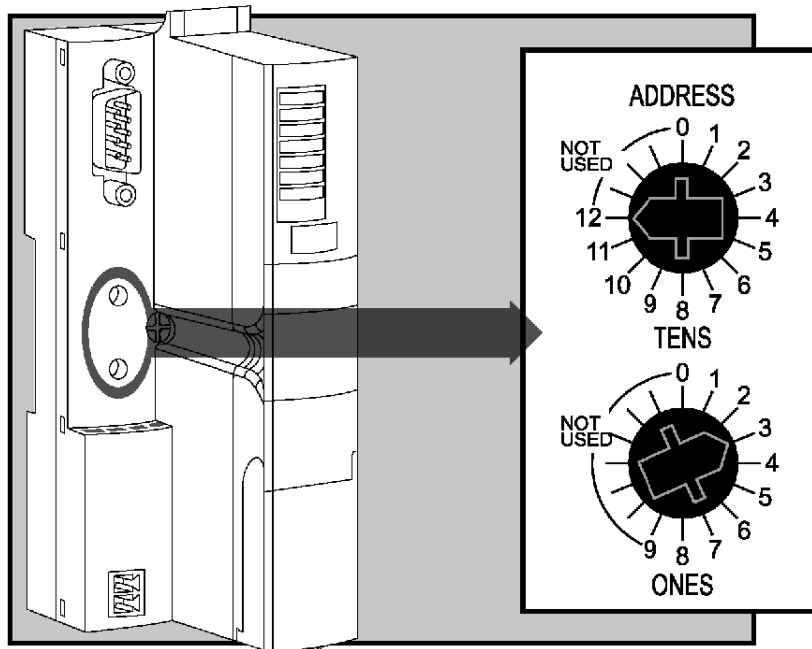

Valid and Invalid Fipio Node Addresses

Each rotary switch position that you can use to set the node address for your island is marked incrementally on the NIM housing. The available positions on each switch are:

- upper switch—0 to 12 (tens digit)
- lower switch—0 to 9 (ones digit)

NOTE: Using both switches, it is mechanically possible to set any node address from 0 to 129. However, Fipio reserves address 0 for the fieldbus master and address 63 for programming and diagnostics. Addresses 128 and 129 are out-of-range. Do not set your node address to an invalid value.

If the island has an invalid node address, it cannot communicate with the master. To establish communication, set the switches to a valid address and cycle power on the island.

Using the Node Address

The node address is *not* saved. Instead, the NIM reads the address from the rotary switches each time that the island is powered up. For this reason, the rotary switches should *always* remain set to the node address. This way, the fieldbus master will identify the island bus at the same node address at each power up.

NOTE: If your Fipio configuration software (e.g., PL7 PRO (*see page 95*)) requires a device address, you **must** provide the island node address that was set with these rotary switches.

Setting the Node Address

Instructions for setting the node address appear in the following table:

Step	Action	Comment
1	Select a node address that is currently available on your fieldbus network.	
2	With a small screwdriver, set the lower rotary switch to the position that represents the digit in the ones position of your node address.	For example, for a node address of 123 set the lower switch to 3.
3	With a small screwdriver, set the upper rotary switch to the position that represents the digit(s) in the tens position of your node address.	Using the example address 123, set the upper switch to 12. The rotary switches in the figure (<i>see page 30</i>) are correctly set to the example address 123.

Step	Action	Comment
4	Power up the island bus.	The NIM reads the rotary switch settings only during power up.
<p>Note: If the node address that you set for the STB NFP 2212 duplicates an existing node address on the same Fipio network or is otherwise invalid, the FIP RUN, FIP ERR, and FIP COM LEDs all blink steadily (<i>see page 33</i>) and bit 5 in word 1 of the Fipio specific channel diagnostic is set to 1 (<i>see page 88</i>).</p>		

LED Indicators

LED Location

All seven LEDs on the STB NFP 2212 are used to indicate the operational status of the island bus (see page 15) on a Fipio network:

- The FIP RUN, FIP ERR, and FIP COM LEDs (see page 33) indicate the status of the Fipio network.
- The RUN, PWR, ERR, AND TEST LEDs indicate events on the Advantys STB island. (see page 35)

The figure illustrates LED usage by the STB NFP 2212. The LED array is located at the top of the NIM's front bezel:

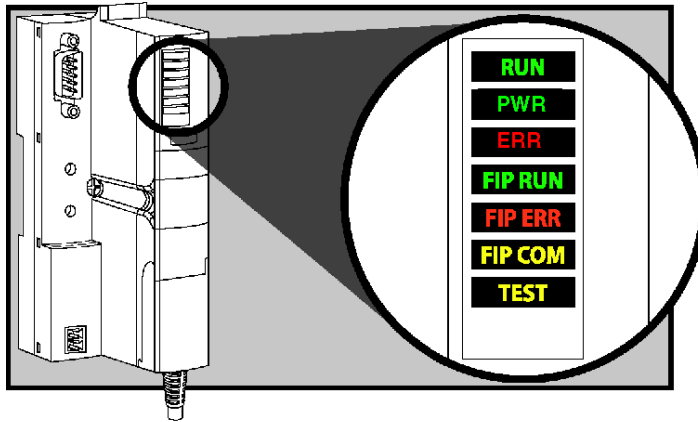

Fipio Communications LEDs

The Fipio communications LEDs indicate the conditions described in the following table:

Label	Pattern	Meaning			
FIP RUN (green)	off	The STB NFP 2212 is powered down.			
	on	The STB NFP 2212 is powered up.			
	flashing ¹	<table border="0"> <tr> <td>in combination with the FIP ERR LED</td> <td>The STB NFP 2212 is initializing.</td> </tr> <tr> <td>in combination with both the FIP ERR and FIP COM LEDs</td> <td>Invalid node address (see page 31)</td> </tr> </table>	in combination with the FIP ERR LED	The STB NFP 2212 is initializing.	in combination with both the FIP ERR and FIP COM LEDs
in combination with the FIP ERR LED	The STB NFP 2212 is initializing.				
in combination with both the FIP ERR and FIP COM LEDs	Invalid node address (see page 31)				

Label	Pattern	Meaning	
FIP ERR (red)	off	No Fipio fault.	
	on	Fatal error on the island or a mandatory node is missing. Note: This LED indication can occur <i>only</i> if the STB NIP 2212 is successfully connected to the Fipio network.	
	flashing ¹		The STB NFP 2212 is not logically connected to the Fipio network.
		in combination with the FIP RUN LED	The STB NFP 2212 is initializing.
	in combination with both the FIP RUN and FIP COM LEDs	Invalid node address (<i>see page 131</i>).	
FIP COM (yellow)	off	No Fipio activity on the fieldbus.	
	flashing ¹		Data exchange.
		in combination with both the FIP RUN and FIP ERR LEDs	Invalid node address (<i>see page 131</i>).
¹ This LED(s) flashes two times per second.			

Advantys STB Island Status LEDs

About the Island Status LEDs

The following table describes:

- the island bus condition(s) communicated by the LEDs
- the colors and blink patterns used to indicate each condition

As you refer to the table, keep in mind the following:

- It is assumed that the *PWR* LED is on continuously, indicating that the NIM is receiving adequate power. If the *PWR* LED is off, logic power (*see page 43*) to the NIM is off or insufficient.
- Individual blinks are approximately 200 ms. There is a 1-second interval between blink sequences. Please note:
 - blinking: blinks steadily, alternating between 200 ms on and 200 ms off.
 - blink 1: blinks once (200 ms), then 1 second off.
 - blink 2: blinks twice (200 ms on, 200 ms off, 200 ms on), then 1 second off.
 - blink *N*: blinks *N* (some number of) times, then 1 second off.
 - If the *TEST* LED is on, either the Advantys configuration software or an HMI panel is the master of the island bus. If the *TEST* LED is off, the fieldbus master has control of the island bus.

Island Status LED Indicators

RUN (green)	ERR (red)	TEST (yellow)	Meaning
blink: 2	blink: 2	blink: 2	The island is powering up (self test in progress).
off	off	off	The island is initializing. The island is not started.
blink: 1	off	off	The island has been put in the pre-operational state by the RST button. The island is not started.
		blink: 3	The NIM is reading from the removable memory card (<i>see page 58</i>).
		on	The NIM is overwriting its Flash memory with the card's configuration data. (See note 1.)
off	blink: 8	off	The contents of the removable memory card are invalid.
blinking (steady)	off	off	The NIM is configuring (<i>see page 51</i>) or auto-configuring (<i>see page 54</i>) the island bus. The island bus is not started.
blinking	off	on	Auto-configuration data is being written to Flash memory. (See note 1.)
blink: 3	blink: 2	off	Configuration mismatch detected after power up. At least one mandatory module does not match. The island bus is not started.

RUN (green)	ERR (red)	TEST (yellow)	Meaning
off	blink: 2	off	The NIM has detected a module assignment error; the island bus is not started.
	blink: 5		invalid internal triggering protocol
off	blink: 6	off	The NIM detects no I/O modules on the island bus.
	blinking (steady)	off	The NIM detects no I/O modules on the island bus ... or ... No further communications with the NIM are possible. Probable causes: <ul style="list-style-type: none"> ● internal condition ● wrong module ID ● device did not auto-address (<i>see page 52</i>) ● mandatory module is incorrectly configured (<i>see page 110</i>) ● process image is not valid ● device is incorrectly configured (<i>see page 54</i>) ● The NIM has detected an anomaly on the island bus. ● receive/transmit queue software overrun
on	off	off	The island bus is operational.
on	blink 3	off	At least one standard module does not match. The island bus is operational with a configuration mismatch.
on	blink: 2	off	There is a serious configuration mismatch (when a module is pulled from a running island). The island bus is now in pre-operational mode because of one or more mismatched mandatory modules.
blink: 4	off	off	The island bus is stopped (when a module is pulled from a running island). No further communications with the island are possible.
off	on	off	Internal condition: The NIM is inoperable.
[any]	[any]	on	Test mode is enabled: The configuration software or an HMI panel can set outputs. (See note 2.)
<p>1 The TEST LED is on temporarily during the Flash overwrite process.</p> <p>2 The TEST LED is on steadily while the device connected to the CFG port is in control.</p>			

Power LED

The PWR (power) LED indicates whether or not the STB NIC 2212's internal power supplies are operating at the correct voltages. The PWR LED is directly driven by the STB NIC 2212's reset circuitry.

The following table summarizes the PWR LED states:

Label	Pattern	Meaning
PWR	Steady on	The STB NIC 2212 internal voltages are all at or above their minimum voltage level.
PWR	Steady off	One or more of the STB NIC 2212 internal voltages is below minimum voltage level.

The CFG Interface

Purpose

The CFG port is the connection point to the island bus for either a computer running the Advantys Configuration Software or an HMI panel.

Physical Description

The CFG interface is a front-accessible RS-232 interface located behind a hinged flap on the bottom front of the NIM:

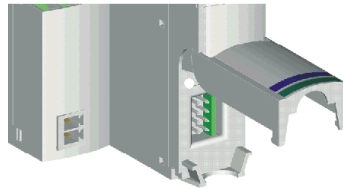

The port uses an 8-pin HE-13 (male) connector.

Port Parameters

The CFG port supports the set of communication parameters listed in the following table. If you want to apply any settings other than the factory default values, you must use the Advantys Configuration Software:

Parameter	Valid Values	Factory Default Settings
bit rate (baud)	2400/4800/9600/19200/ 38400/ 57600	9600
data bits	7/8	8
stop bits	1 or 2	1
parity	none / odd / even	even
Modbus communications mode	RTU	RTU

NOTE: To restore all of the CFG port's communication parameters to their factory default settings, push the RST button (*see page 61*) on the NIM. Be aware, however, that this action overwrites all of the island's current configuration values with factory default values.

If you want to retain your configuration and still use the RST button to reset your port parameters, write the configuration to an STB XMP 4440 removable memory card (*see page 55*) and insert the card in its drawer in the NIM.

You can also password-protect a configuration (*see page 120*). If you do this, however, the RST button is disabled and you are unable to use it to reset the port parameters.

Connections

An STB XCA 4002 programming cable must be used to connect the computer running the Advantys Configuration Software or a Modbus-capable HMI panel to the NIM through the CFG port.

The STB XCA 4002 is a 2 m (6.23 ft) shielded, twisted-pair cable with an 8-receptacle HE-13 (female) connector on one end that plugs into the CFG port and a 9-receptacle SUB-D (female) connector on the other end that plugs into a computer or an HMI panel:

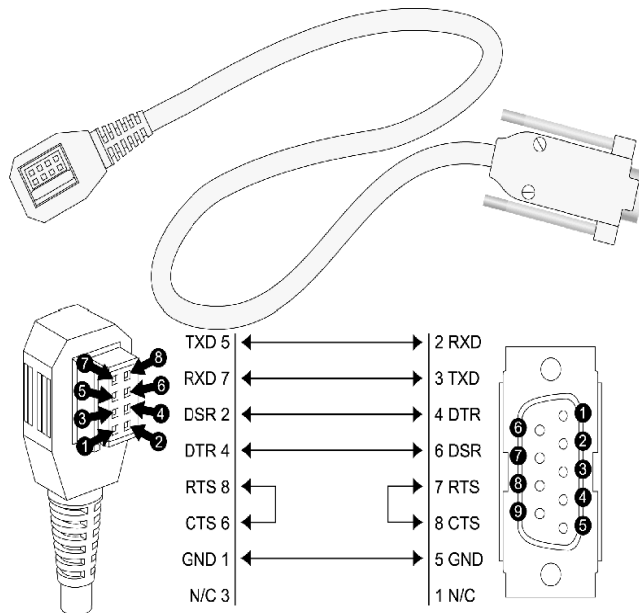

TXD transmit data
RXD receive data
DSR data set ready
DTR data terminal ready
RTS request to send
CTS clear to send
GND ground reference
N/C not connected

The following table describes the specifications for the programming cable:

Parameter	Description
model	STB XCA 4002
function	connection to a device running the Advantys Configuration Software
	connection to an HMI panel
communications protocol	Modbus, either RTU or ASCII mode
cable length	2 m (6.23 ft)
cable connectors	<ul style="list-style-type: none"> ● 8-receptacle HE-13 (female) ● 9-receptacle SUB-D (female)
cable type	multiconductor

The Power Supply Interface

Introduction

The NIM's built-in power supply requires 24 VDC from an external SELV-rated power source. The connection between the 24 VDC source and the island is the two-receptacle connector illustrated below.

Physical Description

Power from the external 24 VDC supply comes into the NIM via a two-pin connector located at the bottom left of the module:

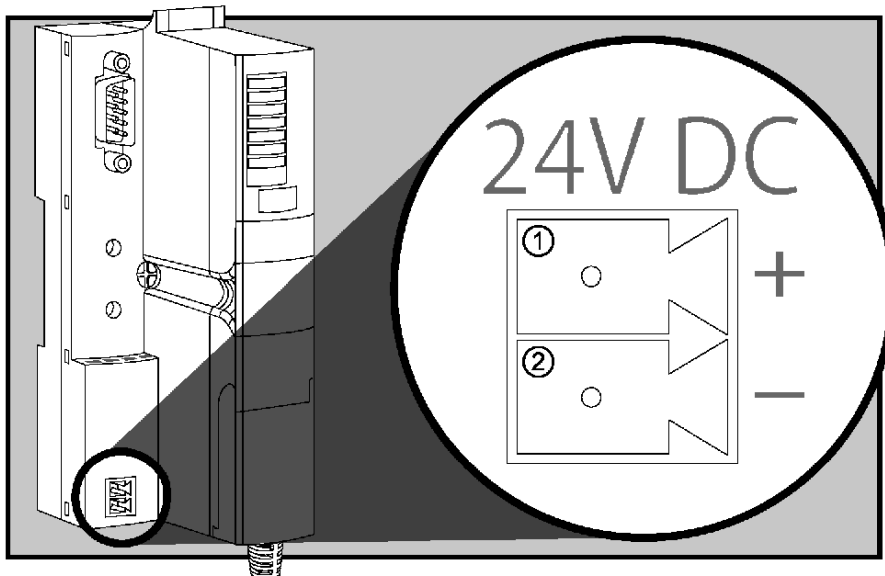

- 1 pin 1–24 VDC
- 2 pin 2–common

Connectors

Screw-type and spring-type connectors are provided with the NIM. Replacement connectors are also available.

The following illustrations show two views of each power connector type. A front and back view of the STB XTS 1120 screw type connector is shown on the left, and a front and back view of the STB XTS 2120 spring clamp connector is shown on the right:

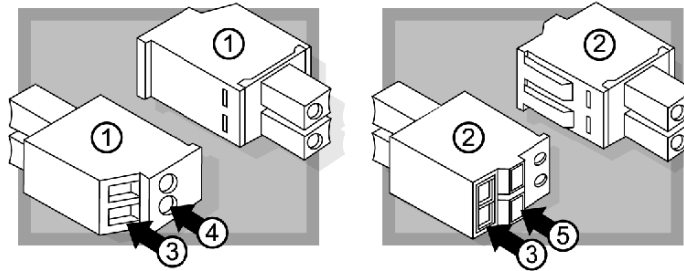

- 1 STB XTS 1120 screw-type power connector
- 2 STB XTS 2120 spring clamp power connector
- 3 wire entry slot
- 4 screw clamp access
- 5 spring clamp actuation button

Each entry slot accepts a wire in the range 0.14 to 1.5 mm² (28 to 16 AWG).

Logic Power

Introduction

Logic power is a 5 VDC power signal on the island bus that the I/O modules require for internal processing. The NIM has a built-in power supply that provides logic power. The NIM sends the 5 V logic power signal across the island bus to support the modules in the primary segment.

External Source Power

⚠ CAUTION
IMPROPER GALVANIC ISOLATION
The power components are not galvanically isolated. They are intended for use only in systems designed to provide SELV isolation between the supply inputs or outputs and the load devices or system power bus. You must use SELV-rated supplies to provide 24 VDC source power to the NIM.
Failure to follow these instructions can result in injury or equipment damage.

Input from an external 24 VDC power supply (*see page 45*) is needed as the source power for the NIM's built-in power supply. The NIM's built-in power supply converts the incoming 24 V to 5 V of logic power. The external supply must be rated *safety extra low voltage* (SELV-rated).

Logic Power Flow

The figure below shows how the NIM's integrated power supply generates logic power and sends it across the primary segment:

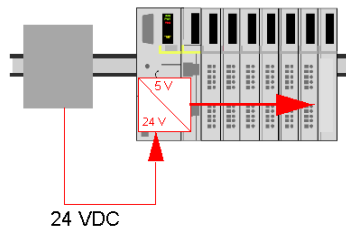

The figure below shows how the 24 VDC signal is distributed to an extension segment across the island:

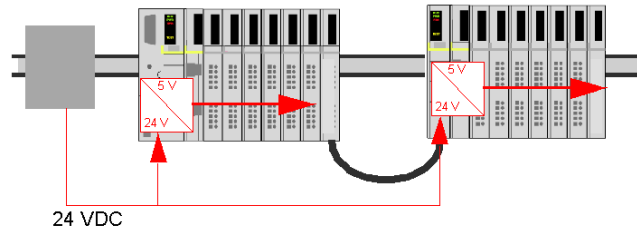

The logic power signal is terminated in the STB XBE 1100 module at the end of the segment (EOS).

Island Bus Loads

The built-in power supply provides logic bus current to the island. If the logic bus current drawn by the I/O modules exceeds the available current, install additional STB power supplies to support the load. Consult the *Advantys STB System Planning and Installation Guide* for the current provided and consumed by Advantys STB modules at various operating temperatures and voltages.

Selecting a Source Power Supply for the Island's Logic Power Bus

Logic Power Requirements

An external 24 VDC power supply is needed as the source for logic power to the island bus. The external power supply connects to the island's NIM. This external supply provides the 24 V input to the built-in 5 V power supply in the NIM.

The NIM delivers the logic power signal to the primary segment only. Special STB XBE 1300 beginning-of-segment (BOS) modules, located in the first slot of each extension segment, have their own built-in power supplies, which provide logic power to the STB I/O modules in the extension segments. Each BOS module that you install requires 24 VDC from an external power supply.

Characteristics of the External Power Supply

CAUTION

IMPROPER GALVANIC ISOLATION

The power components are not galvanically isolated. They are intended for use only in systems designed to provide SELV isolation between the supply inputs or outputs and the load devices or system power bus. You must use SELV-rated supplies to provide 24 VDC source power to the NIM.

Failure to follow these instructions can result in injury or equipment damage.

The external power supply needs to deliver 24 VDC source power to the island. The supply that you select can have a low range limit of 19.2 VDC and a high range limit of 30 VDC. The external supply must be rated *safety extra low voltage* (SELV-rated).

The SELV rating means that, in addition to basic insulation between hazardous voltages and the DC output, a second supplementary insulation layer has been added. As a result, if a single component/insulation does not perform, the DC output does not exceed SELV limits.

Calculating the Wattage Requirement

The amount of power (*see page 43*) that the external power supply must deliver is a function of the number of modules and the number of built-in power supplies installed on the island.

The external supply needs to provide 13 W of power for the NIM and 13 W for each additional STB power supply (like an STB XBE 1300 BOS module). For example, a system with one NIM in the primary segment and one BOS module in an extension segment would require 26 W of power.

Here is an example of an extended island:

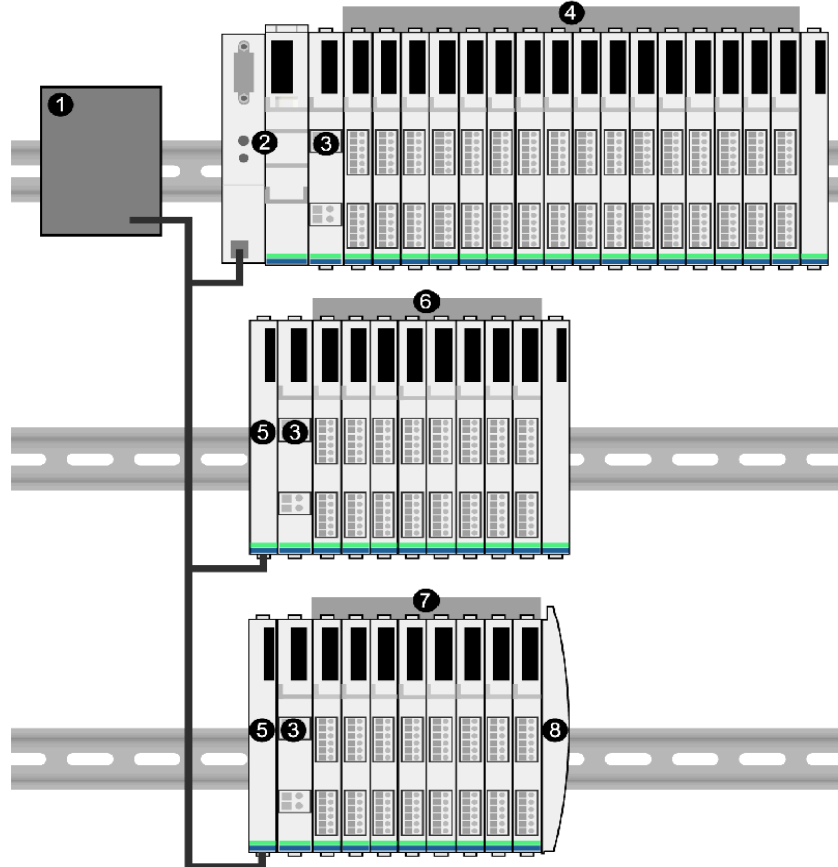

- 1 24 VDC source power supply
- 2 NIM
- 3 PDM
- 4 primary segment I/O modules
- 5 BOS module
- 6 first extension segment I/O modules
- 7 second extension segment I/O modules
- 8 island bus terminator plate

The extended island bus contains three built-in power supplies:

- the supply built into the NIM, which resides in the leftmost location of the primary segment
- a power supply built into each of the STB XBE 1300 BOS extension modules, which reside in the leftmost location of the two extension segments

In the figure, the external supply would provide 13 W of power for the NIM plus 13 W for each of the two BOS modules in the extension segments (for a total of 39 W).

NOTE: If the 24 VDC source power supply also supplies field voltage to a power distribution module (PDM), you must add the field load to your wattage calculation. For 24 VDC loads, the calculation is simply *amps x volts = watts*.

Suggested Devices

The external power supply is generally enclosed in the same cabinet as the island. Usually the external power supply is a DIN rail-mountable unit.

We recommend using ABL8 Phaseo power supplies.

Module Specifications

Specifications Detail

The general specifications for the STB NFP 2212, which is the Fipio network interface module (NIM) for an Advantys STB island bus, appear in the following table:

General Specifications		
dimensions	width	40.5 mm (1.594 in)
	height	130 mm (4.941 in)
	depth	70 mm (2.756 in)
interface and connectors	to the Fipio network	interface is FIPIU chip nine-pin receptacle SUB-D connector (<i>see page 28</i>)
	RS-232 (<i>see page 38</i>) port for device running the Advantys configuration software or HMI panel (<i>see page 143</i>)	eight-pin receptacle HE-13
	to the external 24 VDC power supply	two-receptacle connector (<i>see page 41</i>)
built-in power supply	input voltage	24 VDC nominal
	input power range	19.2 ... 30 VDC
	internal current supply	400 mA @ 24 VDC, consumptive
	output voltage to the island bus	5 VDC
		2% variation due to temperature drift, intolerance, or line regulation
		1% load regulation
		≤50 mΩ output impedance up to 100 kHz
output current rating	1.2 A @ 5 VDC	
isolation	no internal isolation <i>Isolation must be provided by an external 24 VDC source power supply, which must be SELV-rated.</i>	
addressable modules supported (<i>see page 52</i>)	per segment	16 maximum
	per island	32 maximum
segments supported	primary (required)	one
	extension (optional)	six maximum

General Specifications		
standards	Fipio conformance	EN 50170, Vol. 3, Parts 1-3, 2-3, 3-3, 5-3, 6-3, and 7-3
	MTBF	200,000 hours GB (ground benign)
	electromagnetic compatibility (EMC)	EN 61131-2
storage temperature		-40 to 85° C
operating temperature range*		0 to 60° C
agency certifications		refer to the <i>Advantys STB System Planning and Installation Guide, 890 USE 171 00</i>
*This product supports operation at normal and extended temperature ranges. Refer to the <i>Advantys STB System Planning and Installation Guide, 890 USE 171 00</i> for a complete summary of capabilities and limitations.		

How to Configure the Island

3

Introduction

The information in this chapter describes the auto-addressing and auto-configuration processes. An Advantys STB system has an auto-configuration capability in which the actual configuration of I/O modules on the island is read and saved to Flash.

The removable memory card is discussed in this chapter. The card is an Advantys STB option for storing configuration data offline. Factory default settings can be restored to the island bus I/O modules and the CFG port by engaging the RST button.

The NIM is the physical and logical location of all island bus configuration data and functionality.

What's in this Chapter?

This chapter contains the following topics:

Topic	Page
How Do Modules Automatically Get Island Bus Addresses?	52
How to Auto-Configure Default Parameters for Island Modules	54
How to Install the STB XMP 4440 Optional Removable Memory Card	55
Using the STB XMP 4440 Optional Removable Memory Card to Configure the Island	58
What is the RST Button?	61
How to Overwrite Flash Memory with the RST Button	62

How Do Modules Automatically Get Island Bus Addresses?

Introduction

Each time that the island is powered up or reset, the NIM automatically assigns a unique island bus address to each module on the island that engages in data exchange. All Advantys STB I/O modules and preferred devices engage in data exchange and require island bus addresses.

About the Island Bus Address

An island bus address is a unique integer value in the range 1 through 127 that identifies the physical location of each addressable module on the island. The NIM's address is always 127. Addresses 1 through 32 are available for I/O modules and other island devices.

During initialization, the NIM detects the order in which modules are installed and addresses them sequentially from left to right, starting with the first addressable module after the NIM. No user action is required to address these modules.

Addressable Modules

Advantys STB I/O modules and preferred devices are auto-addressable. Enhanced CANopen modules are not auto-addressable. They require manual address settings.

Because they do not exchange data on the island bus, the following are not addressed:

- bus extension modules
- PDMs such as the STB PDT 3100 and STB PDT 2100
- auxiliary power supplies, such as the STB CPS 2111
- termination plate

An Example

For example, if you have an island bus with eight I/O modules:

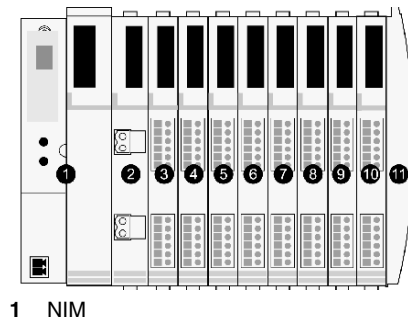

1 NIM

- 2 STB PDT 3100 (24 VDC power distribution module)
- 3 STB DDI 3230 24 VDC (2-channel digital input module)
- 4 STB DDO 3200 24 VDC (2-channel digital output module)
- 5 STB DDI 3420 24 VDC (4-channel digital input module)
- 6 STB DDO 3410 24 VDC (4-channel digital output module)
- 7 STB DDI 3610 24 VDC (6-channel digital input module)
- 8 STB DDO 3600 24 VDC (6-channel digital output module)
- 9 STB AVI 1270 +/-10 VDC (2-channel analog input module)
- 10 STB AVO 1250 +/-10 VDC (2-channel analog output module)
- 11 STB XMP 1100 (island bus termination plate)

The NIM would auto-address it as follows. Note that the PDM and the termination plate do not consume island bus addresses:

Module	Physical Location	Island Bus Address
NIM	1	127
STB PDT 3100 PDM	2	not addressed: does not exchange data
STB DDI 3230 input	3	1
STB DDO 3200 output	4	2
STB DDI 3420 input	5	3
STB DDO 3410 output	6	4
STB DDI 3610 input	7	5
STB DDO 3600 output	8	6
STB AVI 1270 input	9	7
STB AVO 1250 output	10	8
STB XMP 1100 termination plate	11	not applicable

Associating the Module Type with the Island Bus Location

As a result of the configuration process, the NIM automatically identifies physical locations on the island bus with specific I/O module types. This feature enables you to hot swap a non-operational module with a new module of the same type.

How to Auto-Configure Default Parameters for Island Modules

Introduction

All Advantys STB I/O modules are shipped with a set of predefined parameters that allow an island to be operational as soon as it is initialized. This ability of island modules to operate with default parameters is known as auto-configuration. Once an island bus has been installed, assembled, and successfully parameterized and configured for your fieldbus network, you can begin using it as a node on that network.

NOTE: A valid island configuration does not require the intervention of the optional Advantys Configuration Software.

About Auto-Configuration

Auto-configuration occurs under these circumstances:

- The island is powered up with a factory default NIM configuration. (If this NIM is subsequently used to create a new island, auto-configuration does not occur when that new island is powered.)
- You push the RST button (*see page 61*).
- You force an auto-configuration using the Advantys Configuration Software.

As part of the auto-configuration process, the NIM checks each module and confirms that it has been properly connected to the island bus. The NIM stores the default operating parameters for each module in Flash memory.

Customizing a Configuration

In a custom configuration, you can:

- customize the operating parameters of I/O modules
- create reflex actions (*see page 113*)
- add enhanced CANopen standard devices to the island bus
- customize other island capabilities
- configure communication parameters (STB NIP 2311 only)

How to Install the STB XMP 4440 Optional Removable Memory Card

Introduction

CAUTION

LOSS OF CONFIGURATION: MEMORY CARD DAMAGE OR CONTAMINATION

The card's performance can be degraded by dirt or grease on its circuitry. Contamination or damage may create an invalid configuration.

- Use care when handling the card.
- Inspect for contamination, physical damage, and scratches before installing the card in the NIM drawer.
- If the card does get dirty, clean it with a soft dry cloth.

Failure to follow these instructions can result in injury or equipment damage.

The STB XMP 4440 removable memory card is a 32-kbyte subscriber identification module (SIM) that lets you store (*see page 119*), distribute, and reuse custom island bus configurations. If the island is in edit mode and a removable memory card containing a valid island bus configuration is inserted in the NIM, the configuration data on the card overwrites the configuration data in Flash memory, and is adopted when the island starts up. When the island is in protected mode, it ignores the presence of a removable memory card.

The removable memory card is an optional Advantys STB feature.

Remember:

- Keep the card free of contaminants and dirt.
- Network configuration data, such as the fieldbus baud setting, cannot be saved to the card.

Installing the Card

Use the following procedure to install the memory card:

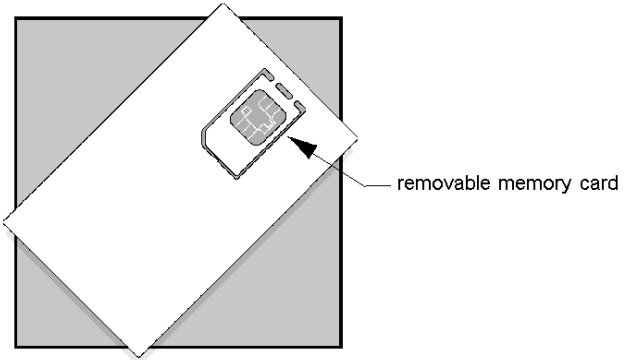
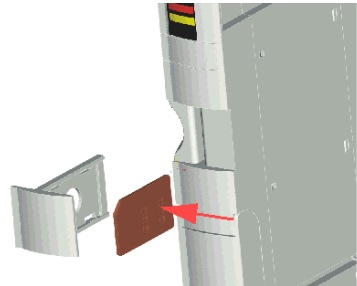
Step	Action
1	<p>Punch out the removable memory card from the plastic card on which it is shipped.</p>  <p>The diagram shows a white plastic card with a grey removable memory card inside. A black arrow points from the text 'removable memory card' to the card. The plastic card is shown being punched out, with a grey square representing the remaining part of the card.</p> <p>removable memory card</p> <p>Make sure that the edges of the card are smooth after you punch it out.</p>
2	<p>Open the card drawer on the front of the NIM. If it makes it easier for you to work, you may pull the drawer completely out from the NIM housing.</p>
3	<p>Align the chamfered edge (the 45° corner) of the removable memory card with the one in the mounting slot in the card drawer. Hold the card so that the chamfer is in the upper left corner.</p>  <p>The diagram shows a grey card drawer with a mounting slot. A red arrow points to the slot. A brown removable memory card is shown being inserted into the slot. The card has a chamfered edge (45° corner) that aligns with the slot.</p>
4	<p>Seat the card in the mounting slot, applying slight pressure to the card until it snaps into place. The back edge of the card must be flush with the back of the drawer.</p>
5	<p>Close the drawer.</p>

Removing the Card

Use the following procedure to remove the memory card from the NIM. As a handling precaution, avoid touching the circuitry on the card.

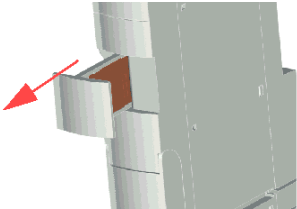
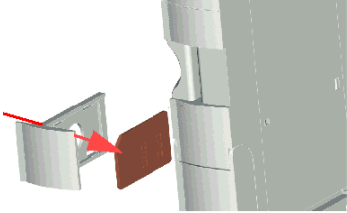
Step	Action
1	Open the card drawer. 
2	Push the removable memory card out of the drawer through the round opening at the back. Use a soft but firm object like a pencil eraser. 

Using the STB XMP 4440 Optional Removable Memory Card to Configure the Island

Introduction

A removable memory card is read when an island is powered on or during a reset operation. If the configuration data on the card is valid, the current configuration data in Flash memory is overwritten.

A removable memory card can be *active* only if an island is in *edit* mode. If an island is in protected mode (*see page 120*), the card and its data are ignored.

Configuration Scenarios

The following discussion describes several island configuration scenarios that use the removable memory card. (The scenarios assume that a removable memory card is already installed in the NIM.):

- initial island bus configuration
- replace the current configuration data in Flash memory in order to:
 - apply custom configuration data to your island
 - temporarily implement an alternative configuration; for example, to replace an island configuration used daily with one used to fulfill a special order
- copying configuration data from one NIM to another, including from a non-operational NIM to its replacement; the NIMs must have the same part number
- configuring multiple islands with the same configuration data

NOTE: Whereas writing configuration data *from* the removable memory card to the NIM does not require use of the optional Advantys Configuration Software, you must use this software to save (write) configuration data *to* the removable memory card in the first place.

Edit Mode

Your island bus must be in edit mode to be configured. In edit mode, the island bus can be written to as well as monitored.

Edit mode is the default operational mode for the Advantys STB island:

- A new island is in edit mode.
- Edit mode is the default mode for a configuration downloaded from the Advantys Configuration Software to the configuration memory area in the NIM.

Initial Configuration and Reconfiguration Scenarios

Use the following procedure to set up an island bus with configuration data that was previously saved (*see page 119*) to a removable memory card. You can use this procedure to configure a new island or to overwrite an existing configuration. (**NOTE:** The use of this procedure destroys your existing configuration data.)

Step	Action	Result
1	Install the removable memory card in its drawer in the NIM (<i>see page 55</i>).	
2	Power on the new island bus.	The configuration data on the card is checked. If the data is valid, it is written to Flash memory. The system restarts automatically, and the island is configured with this data. If the configuration data is invalid, it is not used and the island bus stops. If the configuration data was in edit mode, the island bus remains in edit mode. If the configuration data on the card was password-protected (<i>see page 120</i>), your island bus enters protected mode at the end of the configuration process. NOTE: If you are using this procedure to reconfigure an island bus and your island is in protected mode, you can use the configuration software to change the island's operational mode to edit.

Using the Card and the RST Function to Reconfigure an Island

You can use a removable memory card in combination with the RST function to overwrite the island's current configuration data. The configuration data on the card can contain custom configuration features. Using the data on the card, you can add password protection to your island, change the I/O module assembly, and change the user-modifiable CFG port settings (*see page 38*). *Using this procedure destroys your existing configuration data.*

Step	Action	Comment
1	Place the island bus in edit mode.	If your island is in protected mode, you can use the configuration software to change the island's operational mode to <i>edit</i> .
2	Press the RST button for at least two seconds.	If your configuration data was in edit mode, the island bus remains in edit mode. If the configuration data on the card was protected, your island bus enters protected mode at the end of the configuration process.

Configuring Multiple Island Buses with the Same Data

You can use a removable memory card to make a copy of your configuration data; then use the card to configure multiple island buses. This capability is particularly advantageous in a distributed manufacturing environment or for an OEM (original equipment manufacturer).

NOTE: The island buses may be either new or previously configured, but the NIMs must all have the same part number.

What is the RST Button?

Summary

The RST function is basically a Flash memory overwriting operation. This means that RST is functional only after the island has been successfully configured at least once. All RST functionality is performed with the RST button, which is enabled only in edit mode (*see page 58*).

Physical Description

⚠ CAUTION
UNINTENDED EQUIPMENT OPERATION/CONFIGURATION OVERWRITE—RST BUTTON
Do not attempt to restart the island with the RST button. Pushing the RST button reconfigures the island with default settings (no custom parameters).
Failure to follow these instructions can result in injury or equipment damage.

The RST button is located immediately above the CFG port (*see page 38*), and behind the same hinged cover:

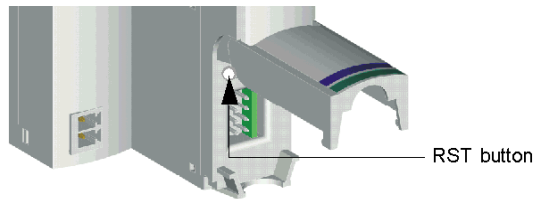

Holding down the RST button for 2 seconds or longer causes Flash memory to be overwritten, resulting in a new configuration for the island.

If the island is already auto-configured, there is no consequence other than the island stops during the configuration process. However, island parameters that you previously customized with the Advantys Configuration Software are overwritten by default parameters during the configuration process.

Engaging the RST Button

To engage the RST button, it is recommended that you use a small screwdriver with a flat blade no wider than 2.5 mm (.10 in). Do not use a sharp object that might damage the RST button, nor a soft item like a pencil that might break off and jam the button.

How to Overwrite Flash Memory with the RST Button

Introduction

CAUTION

UNINTENDED EQUIPMENT OPERATION/CONFIGURATION DATA OVERWRITTEN—RST BUTTON

Do not attempt to restart the island by pushing the RST button. Pushing the RST button (*see page 61*) causes the island bus to reconfigure itself with factory default operating parameters.

Failure to follow these instructions can result in injury or equipment damage.

The RST function allows you to reconfigure the operating parameters and values of an island by overwriting the current configuration in Flash memory. RST functionality affects the configuration values associated with the I/O modules on the island, the operational mode of the island, and the CFG port parameters.

The RST function is performed by holding down the RST button (*see page 61*) for at least two seconds. The RST button is enabled only in edit mode. In protected mode (*see page 120*), the RST button is disabled; pressing it has no effect.

NOTE: Pressing the RST button does not affect network settings.

RST Configuration Scenarios

The following scenarios describe some of the ways that you can use the RST function to configure your island:

- Restore factory-default parameters and values to an island, including to the I/O modules and the CFG port (*see page 38*).
- Add a new I/O module to a previously auto-configured (*see page 54*) island. If a new I/O module is added to the island, pressing the RST button forces the auto-configuration process. The updated island configuration data is automatically written to Flash memory.

Overwriting Flash Memory with Factory Default Values

The following procedure describes how to use the RST function to write default configuration data to Flash memory. Follow this procedure if you want to restore default settings to an island. This is also the procedure to use to update the configuration data in Flash memory after you add an I/O module to a previously auto-configured island bus. *Because this procedure overwrites the configuration data, you may want to save your existing island configuration data to a removable memory card before pushing the RST button.*

Step	Action
1	If you have a removable memory card installed, remove it (<i>see page 57</i>).
2	Place the island in edit mode (<i>see page 58</i>).
3	Hold the RST button (<i>see page 61</i>) down for at least two seconds.

The Role of the NIM in this Process

The NIM reconfigures the island bus with default parameters as follows:

Stage	Description
1	The NIM auto-addresses (<i>see page 52</i>) the I/O modules on the island and derives their factory-default configuration values.
2	The NIM overwrites the current configuration in Flash memory with configuration data that uses the factory-default values for the I/O modules.
3	It resets the communication parameters on its CFG port to their factory-default values (<i>see page 38</i>).
4	It re-initializes the island bus and brings it into operational mode.

Fieldbus Communications Support

4

Introduction

The chapter begins with a description of the Fipio standard profiles and explains how the STB NFP 2212 selects the appropriate profile for an individual island. The chapter continues with a discussion of the Fipio services that the STB NFP 2212 uses. The chapter concludes with an application example describing how to configure a Premium TSX P 57453 processor with a Fipio module as the fieldbus master of an Advantys STB island, and how to configure the island as a Fipio network node.

What's in this Chapter?

This chapter contains the following sections:

Section	Topic	Page
4.1	Before You Begin	66
4.2	Data Exchange	80
4.3	Fipio Application Example	92

4.1 Before You Begin

Introduction

The information in this section is intended as an introduction to Fipio's standard profile types and classes. The information includes the function block type associated with each profile. The applications and network management services used by the STB NFP 2212 are described in this section.

What's in this Section?

This section contains the following topics:

Topic	Page
Standard Profiles	67
FRD Profile	70
FSD Profile	71
FED Profile	73
Network Cycle Time	74
About Class 1 Devices	75
Applications and Network Management Services	77

Standard Profiles

Summary

Every node on a Fipio network must conform to one of three Fipio standard profile (STD_P) types. The STB NFP 2212 ensures that the Advantys STB island node is correctly configured with a standard profile.

Profile Types

The STB NFP 2212 can conform to any of the three Fipio standard profile types. As the following table describes, the correct profile is based on the maximum input or output data size of the island. Note that data in the table includes the bus speed in microseconds (μs) for every profile type:

profile	maximum input/output data size in words	bus speed in μs	diagnostics			benefit
			standard status bits	input validity bits	specific status (in words)	
Fipio reduced device (FRD_P) (see page 70)	1 ... 2	450 μs	8	8		high performance
Fipio standard device (FSD_P) (see page 71)	3 ... 8	700 μs	8	8		compatible with most I/O devices normally used with PLC peripherals
Fipio extended device (FED_P) (see page 73)	9 ... 32	1,500 μs	8	8	eight 16-bit words	configurations with a large volume of I/O data

How the STB NFP 2212 Selects a Standard Profile

After the successful initialization of the STB NFP 2212 on the Fipio network, the STB NFP 2212 scans the island's assembly of modules to determine the total input/output data size.

If an island's configuration is modified, i.e., modules are added to or removed from the island bus, the STB NFP 2212 will automatically detect the correct STD_P for the updated island configuration during the auto-addressing (see page 52) process.

NOTE: The Advantys configuration software can also be used to establish the standard profile for the island. An STD_P set up using the Advantys configuration software will override a profile selected automatically by the STB NFP 2212 unless that profile is *smaller* than the actual island's configuration. If the profile selected with the Advantys configuration software is too small, it will be ignored.

Understanding the Relationship of Function Block Types to Standard Profile Types

Each standard profile type is associated with an automation function, e.g., speed control, and a specific function block (FB). An identifier, expressed in hexadecimal, is associated with each function and with each function block type. These identifiers are globally recognized on the network. Refer to the following table:

Data Volume (in words)	Standard Profile Type (STD_P)	Automation Function Type	Function Block Type
1 ... 2	FRD profile	F2h	A2h
3 ... 8	FSD profile	F0h	7Fh
9 ... 32	FED profile	F1h	A1h

Standard Operating Parameters

An FB corresponds to a standard profile type and comprises a set of operating parameters for a profile. Because a device on a Fipio network must conform to a standard profile, the device will be configured automatically with the required operating parameters.

NOTE: On Fipio networks, operating parameters are typically referred to as *variables*. A unique *identifier* in hexadecimal format is associated with each variable.

The set of standard operating parameters used by the STB NFP 2212 comprises:

- **device name**—STB NFP 2212
- **device reference**—a unique global identifier in hexadecimal format that is used to specify a device’s network location
- **device class**—indicates whether a network device is class (*see page 75*) 0, 1, or 2
- **device promptness value**—time-out value imposed on a producer

Operating Parameters and Values Used by the STB NFP 2212

The Fipio standard operating parameters ensure that every STB NFP 2212 conforms to the Fipio EN 50170 standard. The parameters are mandatory and have the fixed values listed in the following table. *Note: The values for these parameters cannot be modified.*

Type	Value	Description
device name	STB NFP 2212	
device reference	identifier is based on the standard profile type and revision number, as recorded in the <i>WorldFip Fipio Standard Profiles—Reference Manual</i> (FCP DM FSDP V10E) and the <i>FIP I/O Standard Device Library "SDK_FIPIU"—User’s Manual</i> .	A global identifier that is uniquely associated with the device’s network location. The identifier is a legal value in the range of values available for device references.

Type	Value	Description
device_promptness_value	4 seconds	The fieldbus master must update the application_process_control variable within 4 seconds.
class_FB	class 1 (<i>see page 75</i>)	A Fipio system variable that specifies whether a device is class 0, class 1, or class 2. Class 1 devices like the STB NFP 2212 use Fipio's process control features, support operating states, and do not need parameterization.

FRD Profile

Introduction

The STB NFP 2212 will automatically select the Fipio reduced device profile (FRD_P) if an Advantys STB island configuration has two words or less maximum input or output data (*see page 67*).

NOTE: The FRD profile can also be selected using the Advantys configuration software.

Example

The sample Advantys STB island bus assembly shown in the figure below comprises the STB NFP 2212, a 24 VDC PDM, a six-channel STB DDI 3610 digital input module, a four-channel STB DDO 3410 digital output module, and an STB XMP 1100 island bus termination plate

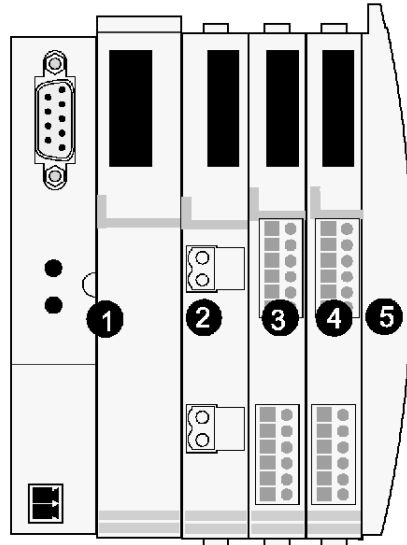

- 1 STB NFP 2212 network interface module (NIM)
- 2 24 VDC power distribution module (PDM)
- 3 STB DDI 3610 six-channel digital input module
- 4 STB DDO 3410 four-channel digital output module
- 5 STB XMP 1100 island bus termination plate

Applying Fipio bit-packing rules (*see page 82*) to the example, the configuration requires two word of input data and one word of output data. Therefore, the FRD_P is a suitable standard profile type.

FSD Profile

Introduction

The STB NFP 2212 will automatically select the Fipio standard device profile (FSD_P) if an Advantys STB island configuration has three to eight words maximum input or output data (*see page 67*).

NOTE: The FSD profile can also be selected using the Advantys configuration software.

Example

The sample Advantys STB island bus assembly shown in the figure below comprises the STB NFP 2212, a 24 VDC PDM, three digital modules, two analog modules, and an STB XMP 1100 island bus termination plate. The specific modules used in this example are described in the figure legend:

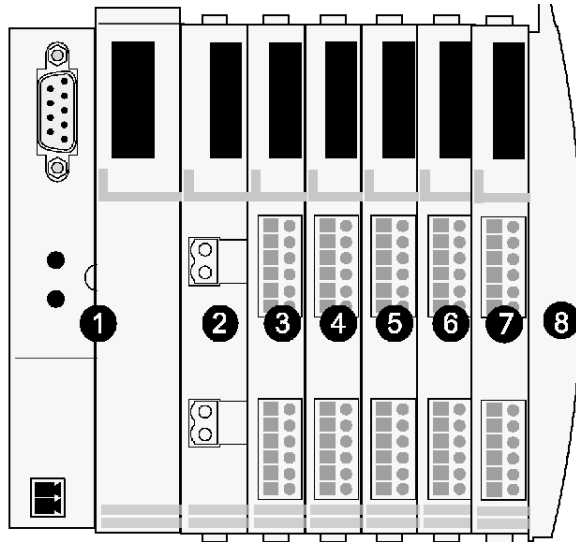

- 1 STB NFP 2212 network interface module
- 2 24 VDC power distribution module
- 3 STB DDI 3420 24 VDC four-channel digital input module
- 4 STB DDO 3410 24 VDC four-channel digital output module
- 5 STB DDO 3600 24 VDC six-channel digital output module
- 6 STB AVI 1270 +/-10 VDC two-channel analog input module
- 7 STB AVO 1250 +/-10 VDC two-channel analog output module
- 8 STB XMP 1100 island bus termination plate

Applying Fipio bit-packing rules (*see page 82*) to the example, the configuration requires seven words of input data and three words of output data. Therefore, the FSD_P is a suitable standard profile type.

FED Profile

Introduction

The STB NFP 2212 will automatically select the Fipio extended device profile (FED_P) if an Advantys STB island configuration has nine to thirty-two words maximum input or output data (*see page 67*).

NOTE: The FED profile can also be selected using the Advantys configuration software.

Example

Our FED_P example includes all of the modules in the sample Advantys STB island (*see page 52*):

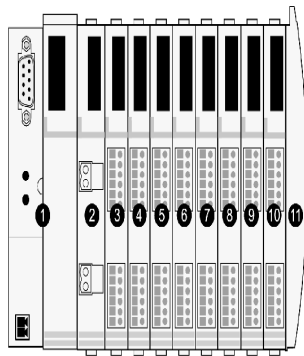

- 1 STB NFP 2212 network interface module
- 2 24 VDC power distribution module
- 3 STB DDI 3230 24 VDC two-channel digital input module
- 4 STB DDO 3200 24 VDC two-channel digital output module
- 5 STB DDI 3420 24 VDC four-channel digital input module
- 6 STB DDO 3410 24 VDC four-channel digital output module
- 7 STB DDI 3610 24 VDC six-channel digital input module
- 8 STB DDO 3600 24 VDC six-channel digital output module
- 9 STB AVI 1270 +/-10 VDC two-channel analog input module
- 10 STB AVO 1250 +/-10 VDC two-channel analog output module
- 11 STB XMP 1100 island bus termination plate

Applying Fipio bit-packing rules (*see page 82*) to the example, the configuration requires nine words of input data and three words of output data. Therefore, the FED_P is the suitable standard profile type.

Network Cycle Time

Summary

Fipio is a time-critical protocol. All application tasks running on a Fipio network are classified according to the amount of time they require to execute. The standard profile type (STD_P) to which a node conforms impacts the amount of time that an application will need to complete on that node and, consequently, on the entire network on which the node resides.

Definition

Network cycle time (NCT) is defined as the amount of time in milliseconds (ms) that the fieldbus master requires to complete a single scan of the configured I/O modules on a network device.

Formula for Calculating the NCT

The formula for calculating network cycle time is: $NCT_Task = 1.45 + S$. The calculation assumes that a single task is running on the network.

- K is a coefficient constant that is dependent on the STD_P type (*see page 74*).
- $S = K$ times the number of devices conforming to the profile type.

The following table lists the coefficient (K) for each STD_P type:

Profile Type	Coefficient K
FRD	0.4
FSD	0.5
FED	1.5

About Class 1 Devices

Introduction

In addition to conforming to a Fipio STD_P, an STB NFP 2212 must conform to a *class*. A device's class defines the Fipio services available to it.

The STB NFP 2212 is a class 1 (09h) device.

Fipio Services

Class 1 devices control process and manage the exchange of digital and analog input and output data. Parameterization of the I/O modules is not a requirement.

- Process control forces the behavior of the output data to totally depend upon the operating modes (*see page 75*) of the fieldbus master.
- On the Advantys STB system, the STB NFP 2212 is the gateway for data exchange to and from the island.

Starting Up a Class 1 Device

Class 1 devices like the STB NFP 2212 become active upon receiving a **start** command from the fieldbus master.

Managing the Operating Mode Table

The operating mode of the fieldbus master changes in conjunction with the various commands listed in the following table:

If the command is ...	Then the operational mode is ...
initialize	idle
start	run
stop	stopped
reset	idle

Operating States of the STB NFP 2212

Regardless of its profile (*see page 67*), the operating state of the STB NFP 2212 depends on the operating mode (*see page 75*) of the fieldbus master and on events originating on the island bus that affect communications. The STB NFP 2212 is always operating in one of the three states described in the following table:

state	value	Purpose
idle	1	The idle state is the initial operating state of an island bus. The island is in the idle state after powering up. Note: In this state, the <code>application_control_variable</code> (<i>see page 77</i>) is ignored. A class 1 device must be in the idle state to be configured. In the case of the Advantys STB system, configuration is accomplished by having the STB NFP 2212 automatically select the correct profile for the island (or setting the profile with the Advantys configuration software).
running	2	Transitioning to the running state means that the Fipio fieldbus master successfully sent the <code>application_control_variable</code> value to the STB NFP 2212 and that no communications errors occurred during the transmission or that the Advantys configuration software has mastery. Note: Data exchange can occur only while the island bus is in the <i>running</i> state.
stopped	3	The STB NFP 2212 enters the stopped state if it receives a stop command from the fieldbus master, or if a serious or fatal communication fault occurs on the island. In this state, the transmission of output data to the NIM's process image is frozen and the output modules on the island retain their last received value(s). If the FIP ERR LED (<i>see page 33</i>) indicates a break in communications to the island, the heartbeat on the island is stopped.

NOTE: The operating state of the island is included in the data reported by the `FB_status` (*see page 77*) variable.

Applications and Network Management Services

Introduction

The following information describes the applications and network management services used by the island node to control process and to manage data exchange (*see page 81*). The services optimize communications between the Fipio fieldbus master and the island, and they ensure the integrity of the data transmitted.

SM_MPS Variables

The STB NFP 2212 uses *state management_message and periodic services* (SM_MPS) variables, exclusively. The MPS applications services allow the STB NFP 2212 to read and write local and remote variables.

MPS Applications Variables Used by the STB NFP 2212

The variables listed in the following table are supported by every STB NFP 2212 regardless of the profile type (*see page 67*). They are used in process control applications written for the island bus:

Variable	Identifier	Description	Purpose
FB_control	03xxh	This variable sets the operational mode for a class 1 (<i>see page 75</i>) device, forcing the output data to depend on the operational mode of the fieldbus master. The FB_control variable can have one of three values: <ul style="list-style-type: none"> ● start ● reset ● stop 	process_control
FB_status	04xxh	This variable reports the operational state (<i>see page 76</i>) of a class 1 device. It confirms that the operating state of the device correctly corresponds to the current value of the FB_control variable.	read_status

Variable	Identifier	Description	Purpose
application_process_control	05xxh	This variable sets the values for the output data that the Fipio fieldbus master sends to a network device. For the STB NFP 2212, this variable sets the values for the Advantys STB output modules and the fieldbus master to HMI output data registers (see page 81).	write_data
application_process_status	06xxh	This variable reports input data values, such as the I/O module input data (see page 84) and the HMI to fieldbus master input data (see page 143).	read_data

Network Management Variables

Traffic management on the Fipio network depends on the use of the SM_MPS variables listed in the following table. Each variable is associated with a fixed identifier, as defined in the EN 50170 standard, Part 3. Note that the definition for each variable includes whether it is produced or consumed (see page 21) by the STB NFP 2212:

Variable	Global Identifier	Producer/Consumer	Purpose
presence_check	9002h	consumed	indicates whether a device is enabled or disabled on the network
segment_parameters	9008h	consumed	ensures the consistency of the data link layer (layer 2) parameters
identification	10xxh ¹	produced	reports the following identification data to the Fipio fieldbus master: <ul style="list-style-type: none"> ● vendor name—Telemecanique ● model name—STB NFP 2212 ● version—revision number ● SM_MPS (see page 77)—supported services ● conformance class—class 1
presence	14xxh ¹	produced	summarizes a device’s operating state and whether or not it is logically connected to the network used by the Fipio fieldbus master to compile a list of all devices present on a network
control	12xxh ¹	consumed	enables the remote transmission of the start , stop , and reset commands
report	11xxh ¹	produced	reports the values of a device’s error and performance counters to the fieldbus master

Variable	Global Identifier	Producer/Consumer	Purpose
Ln_loading	21xxh ¹	produced	reports the logical node configuration, in this case, the configuration of the island
¹ xxh is the node address of the device in hexadecimal format.			

4.2 Data Exchange

Introduction

During data exchange, the Fipio fieldbus master exchanges I/O, diagnostic, and status data with the STB NFP 2212.

What's in this Section?

This section contains the following topics:

Topic	Page
Data Exchange	81
Standard Diagnostic Data	85
Fipio Specific Channel Status Data	87

Data Exchange

Introduction

Data exchange between the fieldbus master and the Advantys STB island bus is cyclic, that is, it occurs automatically and periodically.

During data exchange, first data from the Fipio master is written to the output data image area in the NIM's process image. Next, status and input data information from the I/O modules on the island are placed in the input data image area of the process image, where they can be read by the Fipio master.

Fipio uses a 16-bit word as its data format.

Fipio Data Exchange Services

The STB NFP 2212 relies on two Fipio applications services (*see page 77*) to set the values of the data exchanged between the fieldbus master and the Advantys STB island bus:

- `application_process_control`—contains the values for the output data sent by the Fipio fieldbus master to the island bus. The Advantys STB output modules and the fieldbus master to HMI output data area are consumers of the data.
- `application_process_status`—contains the input data from the island bus and from an HMI panel, if used, that is read by the Fipio fieldbus master.

Data and Status Objects

Data exchange between the island and the fieldbus master involves three object types:

- *data* objects, which are operating values that the Fipio master either reads from the input modules or writes to the output modules
- *status* objects, which are module health records sent to the input process image by all of the I/O modules and read by the Fipio master
- *echo output data* objects, which the digital output modules send to the input process image; these objects are usually a copy of the data objects, but they can contain useful information if a digital output channel is configured to handle the result of a reflex action.

The following table shows the relationship between the different object types and the different module types. It also shows the size of the different objects:

Module Type	Objects in the Input Data Image		Objects in the Output Data Image	
	Objects	Size	Objects	Size
digital input—(8 pt or less)	data	1 byte or less		
	status ¹	1 byte or less		

Module Type		Objects in the Input Data Image		Objects in the Output Data Image	
		Objects	Size	Objects	Size
digital output—(8 pt or less)		echo output data	1 byte or less	data	1 byte max
		status ¹	1 byte or less		
analog input— (16-bit resolution)	channel 1	data	2 bytes		
		status	1 byte		
	channel 2	data	2 bytes		
		status	1 byte		
analog output— (16-bit resolution)	channel 1	status	1 byte	data	2 bytes
	channel 2	status	1 byte	data	2 bytes

¹Status information is not available for every module. For the applicable digital modules, check the *Advantys STB Hardware Components Reference Guide* (890 USE 172 00).

Bit-packing Rules

Bit-packing allows bits associated with the objects for each I/O module to be combined into the same word, according to the following rules:

- Bit-packing follows the addressing order of the island bus I/O modules from left to right, starting with the primary segment.
- The data object (or echo output data object) for a specific module precedes the status object for that module.
- The data object and the status object for the same or different I/O modules may be packed into the same word, if their combined data length is 16-bits or less.
- For analog input modules, the order is channel 1 data, channel 1 status; then channel 2 data, channel 2 status. Because the minimum data length of an analog object is 16-bits (one word), there will be never be data from more than a single analog object in a single word.
- If the combination of objects for a single module requires more than 16-bits, the two objects will be placed in separate contiguous words.
- A single object cannot be split over word boundaries.

A Data Exchange Example

The following example illustrates how data and status objects are exchanged. A sample island comprising eight Advantys STB I/O module, a 24 VDC PDM, and an island bus termination plate are the basis of the example:

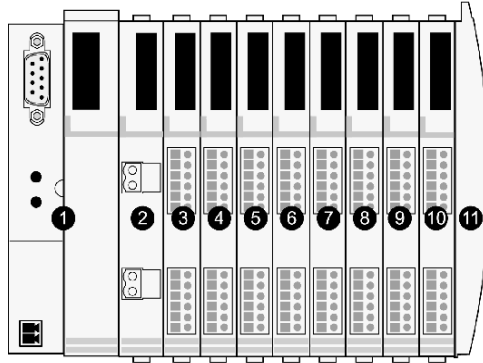

- 1 STB NFP 2212 network interface module
- 2 24 VDC power distribution module
- 3 STB DDI 3230 24 VDC two-channel digital input module
- 4 STB DDO 3200 24 VDC two-channel digital output module
- 5 STB DDI 3420 24 VDC four-channel digital input module
- 6 STB DDO 3410 24 VDC four-channel digital output module
- 7 STB DDI 3610 24 VDC six-channel digital input module
- 8 STB DDO 3600 24 VDC six-channel digital output module
- 9 STB AVI 1270 +/-10 VDC two-channel analog input module
- 10 STB AVO 1250 +/-10 VDC two-channel analog output module
- 11 STB XMP 1100 island bus termination plate

The I/O modules have the following island bus addresses:

I/O Model	Module Type	Module's Island Bus Address
STB DDI 3230	two-channel digital input	N1
STB DDO 3200	two-channel digital output	N2
STB DDI 3420	four-channel digital input	N3
STB DDO 3410	four-channel digital output	N4
STB DDI 3610	six-channel digital input	N5
STB DDO 3600	six-channel digital output	N6
STB AVI 1270	two-channel analog input	N7
STB AVO 1250	two-channel analog output	N8

The PDM and the termination plate are not addressable (*see page 52*), so they exchange neither data objects nor status objects with the fieldbus master.

Input and Output Data Exchange

The application of the Fipio bit packing rules to the sample island bus assembly (see page 83) will result in three words of output data (see page 84) and nine words of input data (see page 84). The tables that follow show how digital data is bit-packed for optimization. In these tables, *N* refers to the island node. That is, N1 represents the first addressable node (module) on the sample island bus, N2 the second, etc.

Output Data Exchange

The data for the *four output modules* in the sample island bus assembly can be bit-packed (see page 82) into *three* 16-bit words. The following table shows the organization of these three words in the output data area:

	Bit Number															
Word	15	14	13	12	11	10	9	8	7	6	5	4	3	2	1	0
1	empty (set to 0)				N6 output data						N4 output data				N2 output data	
2	N8 (channel 1) analog output data															
3	N8 (channel 2) analog output data															

Input Data Exchange

Input data exchange includes all the I/O modules on an Advantys STB island bus that contain status, data, and/or echo output data. After the Fipio bit-packing rules (see page 82) are applied to the I/O modules in the sample island bus assembly, *nine* 16-bit words are required. The following table shows the organization of these nine words in the input data area:

	Bit Number															
Word	15	14	13	12	11	10	9	8	7	6	5	4	3	2	1	0
1	N3 input status				N3 input data				N2 output status		N2 echo output data		N1 input status		N1 input data	
2	empty (set to 0)		N5 input data						N4 output status				N4 echo output data			
3	empty (set to 0)				N6 echo output data						N5 input status					
4	empty (set to 0)										N6 output status					
5	N7 (channel 1) analog input data															
6	empty (set to 0)								N7 (channel 1) analog input status							
7	N7 (channel 2) analog input data															
8	N8 (channel 1) analog output status								N7 (channel 2) analog input status							
9	empty (set to 0)								N8 (channel 2) analog output status							

Standard Diagnostic Data

Introduction

All three standard profiles (STD_Ps) to which the STB NFP 2212 can conform require the device manufacturer to provide two words of standard diagnostic data. The manufacturer defines how its device uses each bit of standard diagnostic data, observing the guidelines and constraints established by Fipio.

- *standard channel data*—communicates fatal errors and device mastery of the output process image area in the STB NFP 2212 to the Fipio fieldbus master
- *validity of inputs*—communicates whether or not the input data received from the island bus is valid

The rest of this discussion describes how the standard channel data diagnostic (*see page 85*) and the validity of inputs diagnostic (*see page 86*) are defined for an Advantys STB node on a Fipio network.

About Explicit Data Exchange

Fipio classifies the standard channel data and the validity of inputs diagnostics as *explicit* data. Explicit data is not exchanged automatically, but only upon request from the fieldbus master.

PL7 Addresses for Standard Channel and Validity of Inputs Diagnostic Data

The PL7 addresses used for the standard channel data and the inputs validity states are shown in the table below. Descriptions of the individual standard channel bits and the validity states used by an Advantys STB island node follow the table.

PL7 Address & Description	bit no.														
	15	14	13	12	11	10	9	8	7	6	5	4	3	2	1
%MWp.2.c\0.0.2 mappings for standard channel bits	reserved								standard channel bits D0 ... D7 (<i>see page 85</i>)						
%MWp.2.c\0.0.3 standard channel validity of inputs	reserved								validity of input data (<i>see page 86</i>)						

Standard Channel Status Diagnostic

The following table describes how each bit in the standard channel diagnostic is defined for the STB NFP 2212. If an error occurs, a fault bit is set:

Bit	Meaning of Value
D0	Data overflow—more than 32 words were mapped.
D1	Device failure.

Bit	Meaning of Value
D2	Not used.
D3	A value of 1 indicates that the Advantys configuration software or an HMI panel has mastery of the output data. A value of 0 indicates that the fieldbus master has mastery of the output data.
D4	Internal failure—at least one global bit (<i>see page 90</i>) was set to 1.
D5	Island bus hardware configuration fault.
D6	Communication failure with the fieldbus master.
D7	Application error.
D8 ... D15	Reserved.

Validity of Inputs

The inputs validity byte indicates whether or not the input data is valid. If all of the input values are valid, this byte is set to 00h, and the Fipio fieldbus master can accept and use the values.

The hex codes in the following table indicate the nature and the level of severity of the fault:

State	Meaning of Value
00h	The input data from the island bus to the standard channel diagnostic is valid.
01h	At least one standard channel diagnostic bit (D0 ... D6) was set to 1.
02h	Serious fault—standard channel status bit 0 was set to 1.
03h ... FFh	Reserved.

Fipio Specific Channel Status Data

Introduction

The following information describes the specific status diagnostic data that can be reported *only* for those STB NFP 2212s that conform to the Fipio extended device profile (FED_P) (*see page 73*). Devices fitting the FRD_P (*see page 70*) and FSD_P (*see page 71*) profiles do not support specific channel status diagnostic data.

Specific Channel Status Summary

The eight words of data that are used to report the specific channel status are summarized in the following table:

word	PL7 Address	bit no.															
		15	14	13	12	11	10	9	8	7	6	5	4	3	2	1	0
1 (<i>see page 88</i>)	%MWp.2.c\0.0.4	NIM device status—all NIMs (<i>see page 131</i>)								NIM device status—STB NFP 2212 specific (<i>see page 131</i>)							
2 (<i>see page 89</i>)	%MWp.2.c\0.0.5	island bus diagnostics (<i>see page 124</i>)								island bus states (<i>see page 124</i>)							
3 (<i>see page 90</i>)	%MWp.2.c\0.0.6	global bits (<i>see page 125</i>)															
4 (<i>see page 91</i>)	%MWp.2.c\0.0.7	island address of module(s) with an internal fault								island address of module(s) with assembly error (<i>see page 127</i>)							
word	operational error (<i>see page 127</i>)	module no.															
5	%MWp.2.c\0.0.8	16	15	14	13	12	11	10	9	8	7	6	5	4	3	2	1
6	%MWp.2.c\0.0.9	32	31	30	29	28	27	26	25	24	23	22	21	20	19	18	17
7	%MWp.2.c\0.0.10	48	47	46	45	44	43	42	41	40	39	38	37	36	35	34	33
8	%MWp.2.c\0.0.11	64	63	62	61	60	59	58	57	56	55	54	53	52	51	50	49

Word 1

Word 1 (*see page 87*) presents the Fipio’s fieldbus master’s view of the NIM status diagnostic register (*see page 131*) in the process image. Each bit in the NIM status word indicates a specific error or event. The status information in bits 0 through 7 is specific to the STB NFP 2212; all Advantys STB NIMs report the information in bits 8 through 15:

Bit	Value	Meaning of Value
D3 ... D0 combined	0000	Island configuration check.
	0001	Initialization of the STB NFP 2212 Fipio handler.
	0010	Data exchange.
	0011	Fault checking.
D4	0	The island bus is operational.
	1	The island bus is stopped.
D5	0	The Fipio node address is valid.
	1	Invalid Fipio node address.
D6	0	Standard profile type selected via Advantys configuration software is accurate.
	1	Standard profile type selected via Advantys configuration software is too small and will be ignored. Standard profile type determined by auto-addressing will be used.
D7		Reserved.
D8 ¹	1	Device failure.
D9 ¹	1	Internal failure—at least one global bit (<i>see page 90</i>) was set to 1.
D10 ¹	1	External failure—problem with the fieldbus master.
D11	0	A value of 0 indicates that the configuration is unprotected.
	1	A value of 1 indicates that the island bus configuration is protected (<i>see page 120</i>).
D12	0	A value of 0 indicates that the contents of the removable memory card (<i>see page 58</i>) is valid.
	1	A value of 1 indicates that the contents of the removable memory card (<i>see page 58</i>) is invalid.
D13	1	A value of 1 in bit 13 indicates that reflex action functionality has been configured. (For NIMs with firmware version 2.0 or greater.)
D14	1	A value of 1 in bit 14 indicates that one or more island modules have been hot-swapped. (For NIMs with firmware version 2.0 or greater.)
D15	0	A value of 0 indicates that the fieldbus master has mastery of the output data.
	1	A value of 1 indicates that the Advantys configuration software or an HMI panel has mastery of the output data.
¹ fatal error		

Word 2

The low byte (*see page 87*) in word 2 is used to provide diagnostic data, in hex format, about the state of communications across the island bus.

Byte Value	Meaning
000h	The island is initializing.
0040h	The island bus has been set to pre-operational mode, for example, by the reset function.
0060h	The NIM is configuring or auto-configuring—communication to all modules is reset.
0061h	The NIM is configuring or auto-configuring (<i>see page 54</i>)—checking the module IDs.
0062h	The NIM is auto-addressing (<i>see page 52</i>) the island.
0063h	The NIM is configuring or auto-configuring—boot-up is in progress.
0064h	The process image is being set up.
0080h	Initialization is complete, the island bus is configured, the configuration matches, and the island bus is not started.
0081h	Configuration mismatch—non-mandatory or unexpected modules in the configuration do not match, and the island bus is not started.
0082h	Configuration mismatch—at least one mandatory module does not match, and the island bus is not started.
0083h	Serious configuration mismatch—the island bus has been set to pre-operational mode, and initialization is aborted.
00A0h	The configuration matches, and the island bus is operating.
00A1h	The island is operational with a configuration mismatch. At least one standard module does not match, but all the mandatory modules are present and operating.
00A2h	Serious configuration mismatch—the island bus was started but is now in pre-operational mode because of one or more mismatched mandatory module(s).
00C0h	The island has been set to pre-operational mode, for example, by the stop function.

The high byte (*see page 87*) in word 2 contains diagnostic data about errors that affect the entire island. A value of 1 in a bit indicates that an error has occurred.

Bit Value	Meaning
D8 ¹	Low-priority receive queue software overrun error.
D9 ¹	NIM overrun error.
D10 ¹	Island bus-off error.
D11	The error counter in the NIM has reached the warning level, and the error status bit was set.
D12	The NIM's error status bit has been reset.
D13 ¹	Low-priority transfer queue software overrun error.
D14 ¹	High-priority receive queue software overrun error.

Bit Value	Meaning
D15 ¹	High-priority transfer queue software overrun error.
¹ fatal error	

Word 3

Word 3 (*see page 87*) is the global-bits diagnostic. It provides information about events and errors occurring in the COMS area of the NIM. The COMS is the island bus scan area; it is the part of the NIM firmware that exchanges data with the island.

Bit	Meaning
D0 ¹	Fatal error—because of the severity of the error, no further communications are possible on the island bus.
D1 ¹	Module ID error—a standard CANopen device is using a module ID reserved for the Advantys STB modules.
D2 ¹	Auto-addressing (<i>see page 52</i>) has failed.
D3 ¹	Mandatory module configuration error.
D4*	Process image (<i>see page 133</i>) error—either the process image configuration is inconsistent or it could not be set up during auto-configuration.
D5 ¹	Auto-configuration (<i>see page 54</i>) error—a module has been detected out of order and the NIM can not complete auto-configuration.
D6	Island bus management error detected by the NIM.
D7 ¹	Assignment error—the initialization process in the NIM has detected a module assignment error, possibly the result of application parameter mismatches.
D8 ¹	Internal triggering protocol error.
D9 ¹	Module data length error.
D10 ¹	Module configuration error.
D11	Application parameter error.
D12	Application parameter services or timeout error.
D13	Reserved.
D14	
D15	
¹ fatal error	

Word 4

The low byte (*see page 87*) in word 4 identifies the address of the island bus module with an assembly error. An assembly error occurs if the expected module is not in its configured location. For example, island bus location N4 was configured for an Advantys STB DDO 3420 module; instead, an Advantys STB DDO 3600 module is located at N4.

The high byte (*see page 87*) of word 4 is used to identify the island bus address of a module with an internal fault.

NOTE: If more than one module has an internal fault or an assembly error, the island bus address provided in both the low and the high bytes of word four is *always* that of the lower module.

Words 5 through 8

Words 5 through 8 indicate whether or not a particular island bus module is operating (*see page 87*). In this diagnostic, each of 64 modules is represented by a dedicated bit. A value of 1 shows that the node is operational on the network.

4.3 Fipio Application Example

Introduction

Many of the Telemecanique Premium processors are equipped with an integrated Fipio master—among them, the Premium TSX P 5725x/5735x/5745x, TSMX P5735x/45x, TPCX P57351x, and several legacy processors.

The application example presented in this section uses the Premium TSX P 57453 CPU and PL7 PRO software.

What's in this Section?

This section contains the following topics:

Topic	Page
Physical Network	93
Configuring the Premium TSX P 57453 Using PL7 PRO	95

Physical Network

Connection Diagram

The following diagram shows the hardware components used in our TSX P 57453 Fipio fieldbus master application example. In the example, an STB NFP 2212 NIM is connected to a Premium PLC over a Fipio network:

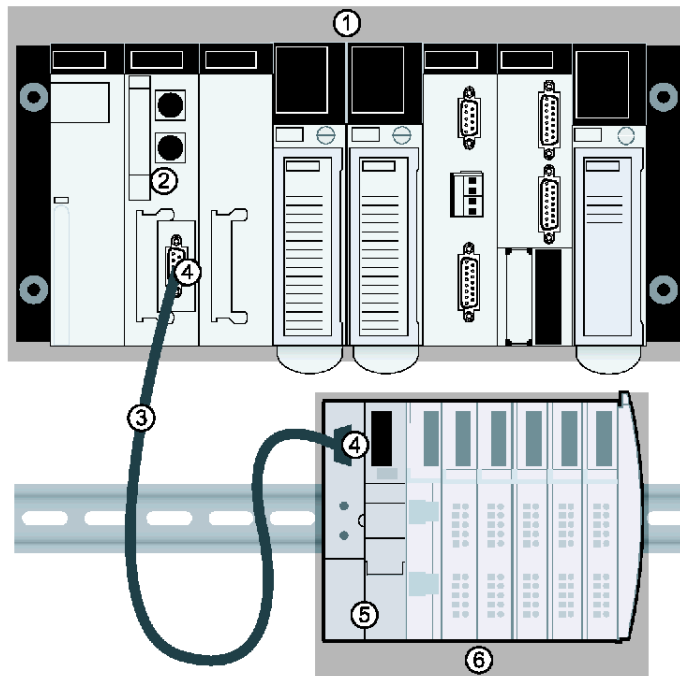

- 1 Premium controller configuration
- 2 TSX P 57453 CPU with an integrated Fipio fieldbus master
- 3 Fipio trunk cable TSX FB Cx e00
- 4 two TSK FP ACC12 Fipio connectors and terminators
- 5 the STB NFP 2212 Fipio NIM in position in an Advantys STB island
- 6 Advantys STB I/O modules

CAUTION

UNINTENDED EQUIPMENT OPERATION

Read and understand this manual and the TSX P 57453 Premium Fipio user's manual before installing or operating this equipment. Installation, adjustment, repair and maintenance of this equipment must be performed by qualified personnel.

- Disconnect all power to the Premium PLC before making the network connection.
- You are responsible for conforming to all applicable code requirements with respect to grounding all equipment.

Failure to follow these instructions can result in injury or equipment damage.

Configuring the Premium TSX P 57453 Using PL7 PRO

Introduction

This topic assumes that you have successfully installed your processor and the PL7 PRO software.

NOTE: You may find it helpful to refer to your *PL7 Communications Applications* (TLX DS COMPLxx) documentation as you complete the configuration procedures that follow.

Configuration Program

The following procedure explains how to configure the TSX P 57453 as the Fipio fieldbus master for the Advantys STB sample assembly (see page 52) with an STB NFP 2212 NIM.

Step	Action	Result
1	From your desktop, double click the PL7 icon. Then select Hardware Configuration from the list in the Application Browser.	The TSX P 57453 (rack x position x) appears in the Hardware Configuration window.
2	Double click on the TSX P 57453 to display the Fipio module configuration screen:	

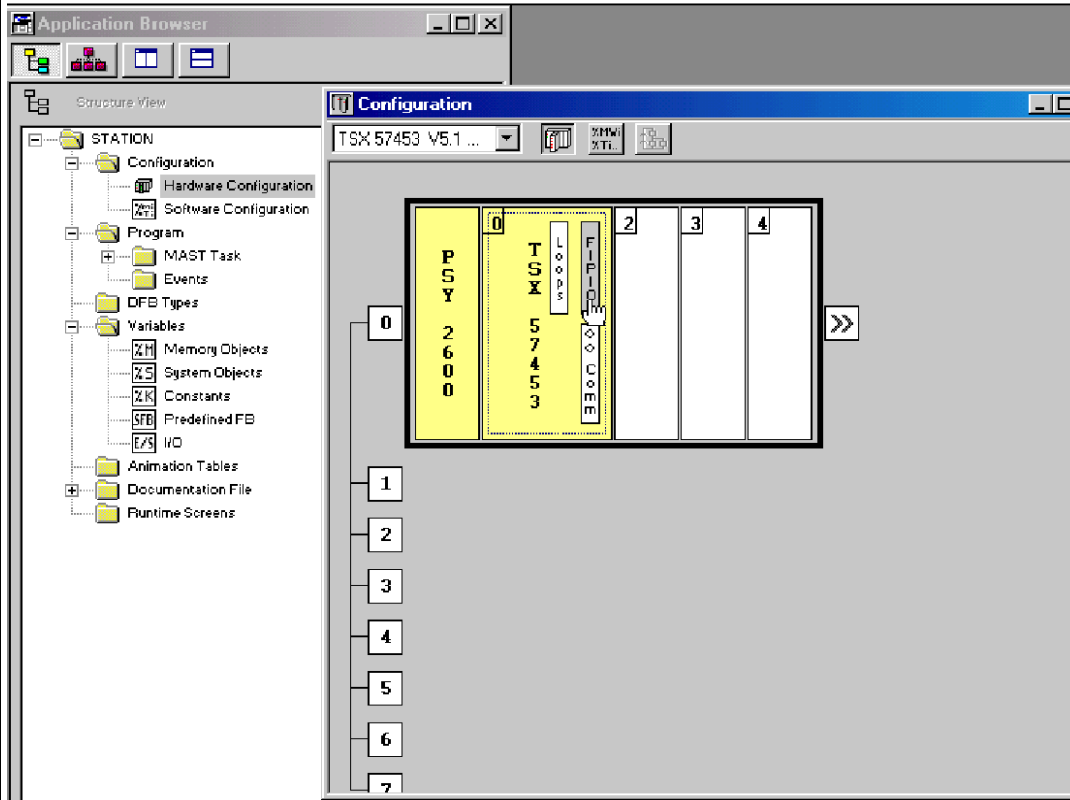

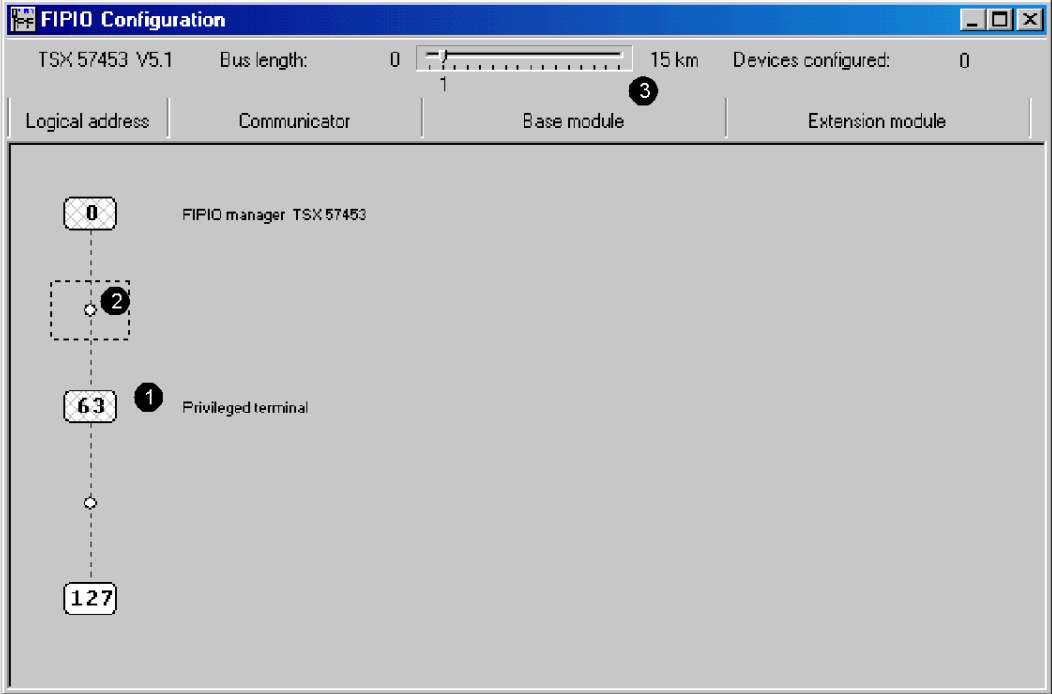
Step	Action	Result
3	<p>The Fipio Configuration screen is displayed. It shows the default (minimum) configuration for a Fipio bus.</p>  <p>1 reserved addresses: 0—fieldbus master (manager); 63—privileged terminal 2 available addresses 3 length of Fipio bus in kms</p>	<p>The Fipio Configuration screen is displayed. It shows the default (minimum) configuration for a Fipio bus.</p>
4	<p>Drag the indicator on the bus length scale to the correct number of kms for your installation. For the example, we will leave the length set to 1 km.</p>	<p>Note: The bus length value that you set up on the Fipio Configuration screen is used to time signals to and from the Advantys STB island bus. The Fipio fieldbus master uses this value to calculate the correct network cycle time (<i>see page 74</i>) for your Advantys STB island.</p>
5	<p>Double click on a small circle representing an available address to open the Add/Modify a Device (<i>see page 98</i>) window.</p>	<p>The catalog of devices that can be connected to the Fipio network at the specified location is displayed.</p>

Adding the Advantys STB Island to the Network

Adapt the following procedure showing how to set up the sample island bus on a Fipio network to your Advantys STB island:

Step	Action
1	On the Add/Modify a Device screen: <ul style="list-style-type: none">● Select STD_P from the Families list because an STB NFP 2212 always conforms to one of the Fipio STD_Ps.● Then select FED (<i>see page 73</i>) C32 because an Advantys STB island is a compact device and the sample island bus (<i>see page 52</i>) has an input data length of nine words and an output data length of three words.
2	At the Connection point number field, you <i>must</i> type the value that you assigned as the node address for your STB NFP 2212 with the NIM's rotary switches (<i>see page 30</i>). For this example, we will use the default connection point value <i>1</i> .
3	80 characters are available for typing an optional comment about the device that you are connecting. For this example, type <i>Island1</i> in the Comment field.

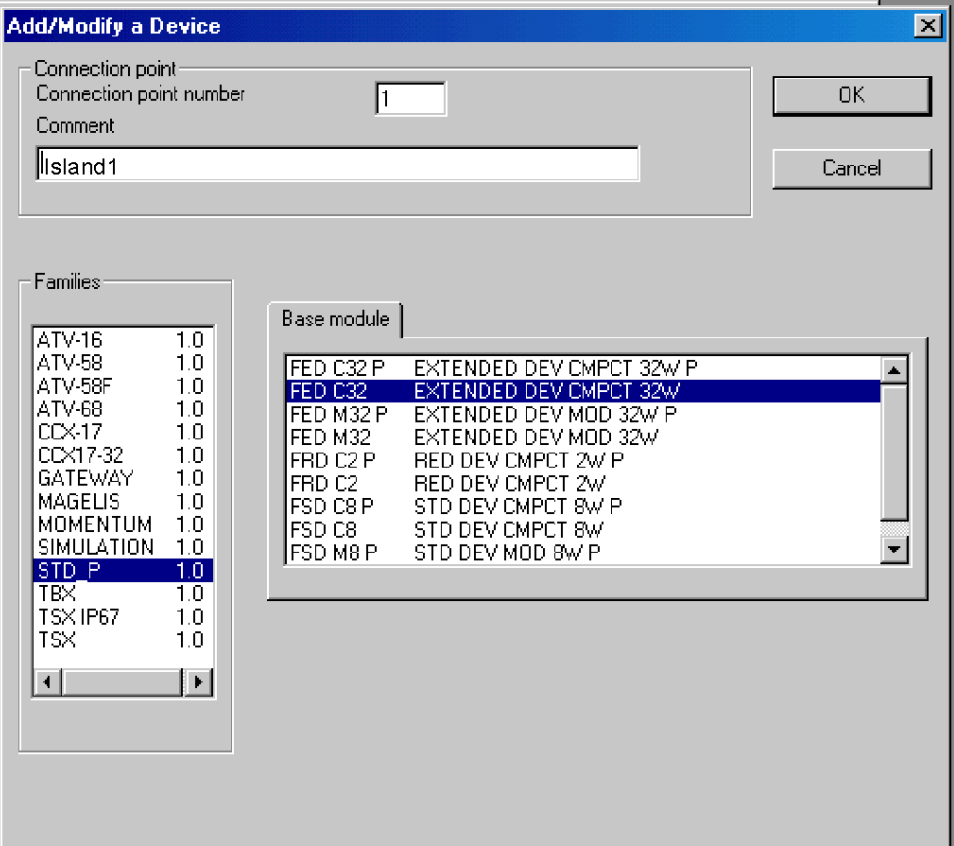
Step	Action
4	<p data-bbox="214 201 1226 225">A completed Add/Modify a Device screen is shown below as an example. Click on OK to accept it.</p>  <p data-bbox="225 266 1181 467"> Add/Modify a Device </p> <p data-bbox="257 310 976 467"> Connection point Connection point number: 1 Comment: Island1 </p> <p data-bbox="257 521 456 1000"> Families ATV-16 1.0 ATV-58 1.0 ATV-58F 1.0 ATV-68 1.0 CCX-17 1.0 CCX17-32 1.0 GATEWAY 1.0 MAGELIS 1.0 MOMENTUM 1.0 SIMULATION 1.0 STD_P 1.0 TBX 1.0 TSX IP67 1.0 TSX 1.0 </p> <p data-bbox="495 553 1153 849"> Base module FED C32 P EXTENDED DEV CMPCT 32W P FED C32 EXTENDED DEV CMPCT 32W FED M32 P EXTENDED DEV MOD 32W P FED M32 EXTENDED DEV MOD 32W FRD C2 P RED DEV CMPCT 2W P FRD C2 RED DEV CMPCT 2W FSD C8 P STD DEV CMPCT 8W P FSD C8 STD DEV CMPCT 8W FSD M8 P STD DEV MOD 8W P </p>
5	The Fipio fieldbus master verifies your device setup.

Enabling I/O Data Exchange

After verification (*see page 98*), the Fipio Configuration (*see page 96*) window redisplay. An FED C32 module representing the STB NFP 2212 is located at the address that you assigned. Use the following steps to complete the configuration process for your island.

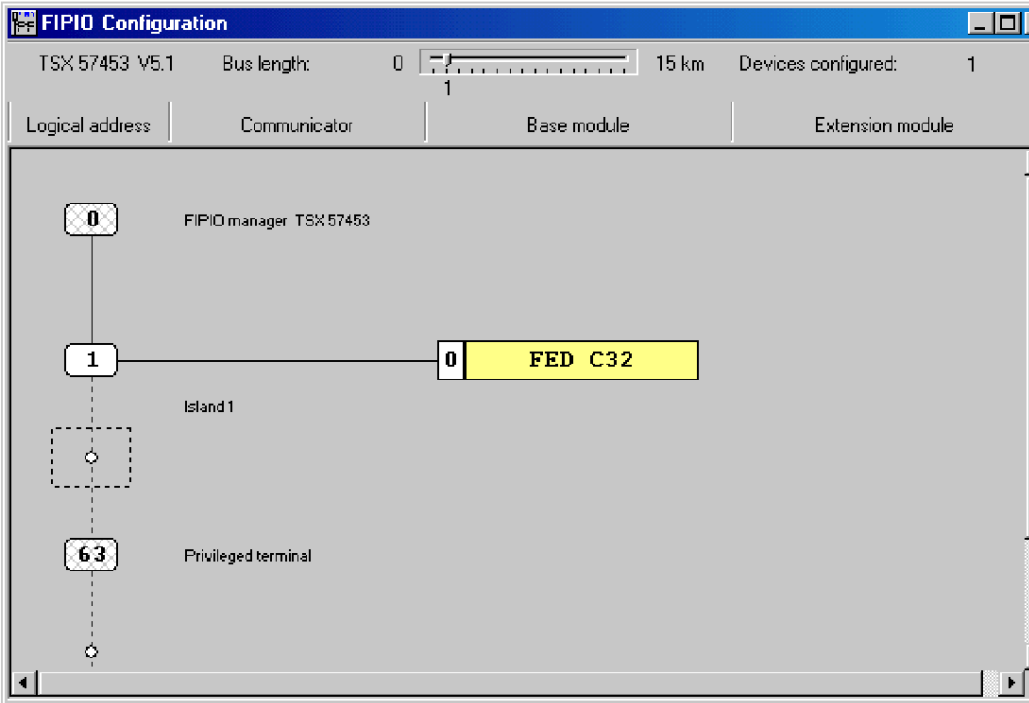
Step	Action
1	<p data-bbox="308 198 975 224">Click on the FED C32 module representing your Advantys STB island:</p>  <p>The screenshot shows the 'FIPIO Configuration' window. At the top, it displays 'TSX 57453 V5.1' and 'Bus length: 0' to '15 km' with a slider set to '1'. It also shows 'Devices configured: 1'. Below this is a table with columns: Logical address, Communicator, Base module, and Extension module. The main area contains a diagram of a bus structure. A vertical line represents the bus, with nodes at addresses 0, 1, and 63. Node 0 is labeled 'FIPIO manager TSX 57453'. Node 1 is labeled 'Island 1'. Node 63 is labeled 'Privileged terminal'. A yellow box labeled 'FED C32' is connected to node 1.</p>

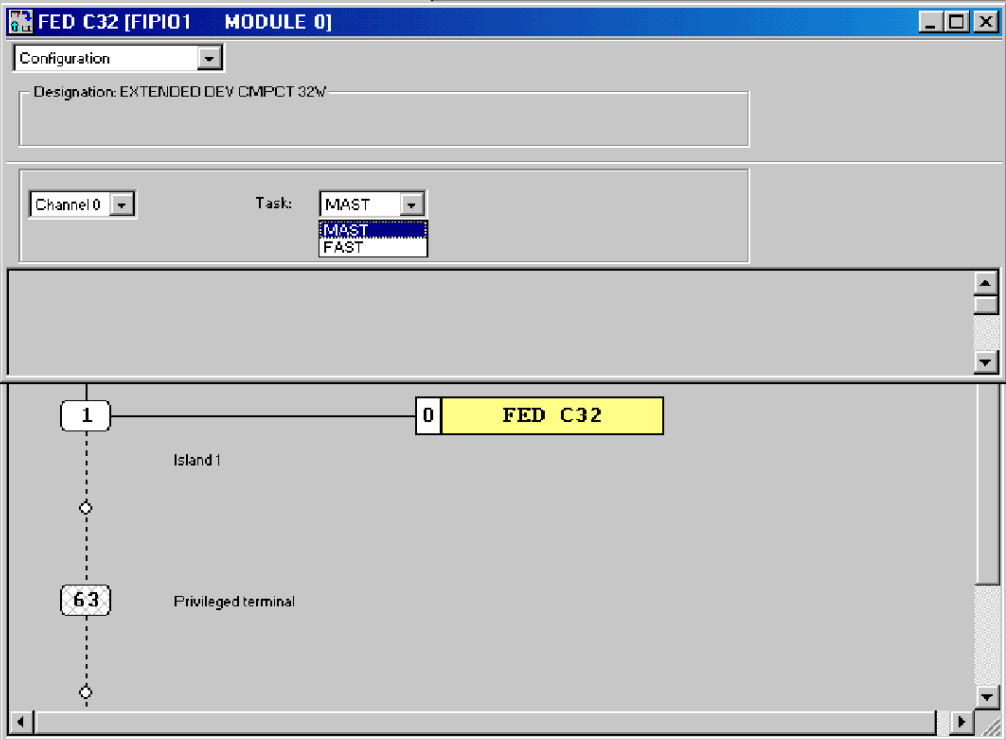
Step	Action
2	<p>Select whether I/O data exchange should be executed in Mast or Fast mode:</p>  <ul style="list-style-type: none"> ● Mast—The priority assigned to a Mast task cannot be modified. A Mast task is executed in the order that it appears in the master’s scan list. ● Fast—The priority assigned to a Fast task cannot be modified. A Fast task is executed in the order that it appears in the master’s scan list.

Global Confirmation

The completed configuration of the Advantys STB island bus must be confirmed. Not only must the island configuration be complete, but also it cannot violate any network limitation. For example, the data length of the Advantys STB island bus cannot extend a network beyond the 64 word limit.

NOTE: If the island bus configuration violates a network constraint, a window in which the fault is described is displayed.

If the configuration is successfully confirmed, Fipio generates a scan table of variables for the FED_P island bus and displays the following dialog box:

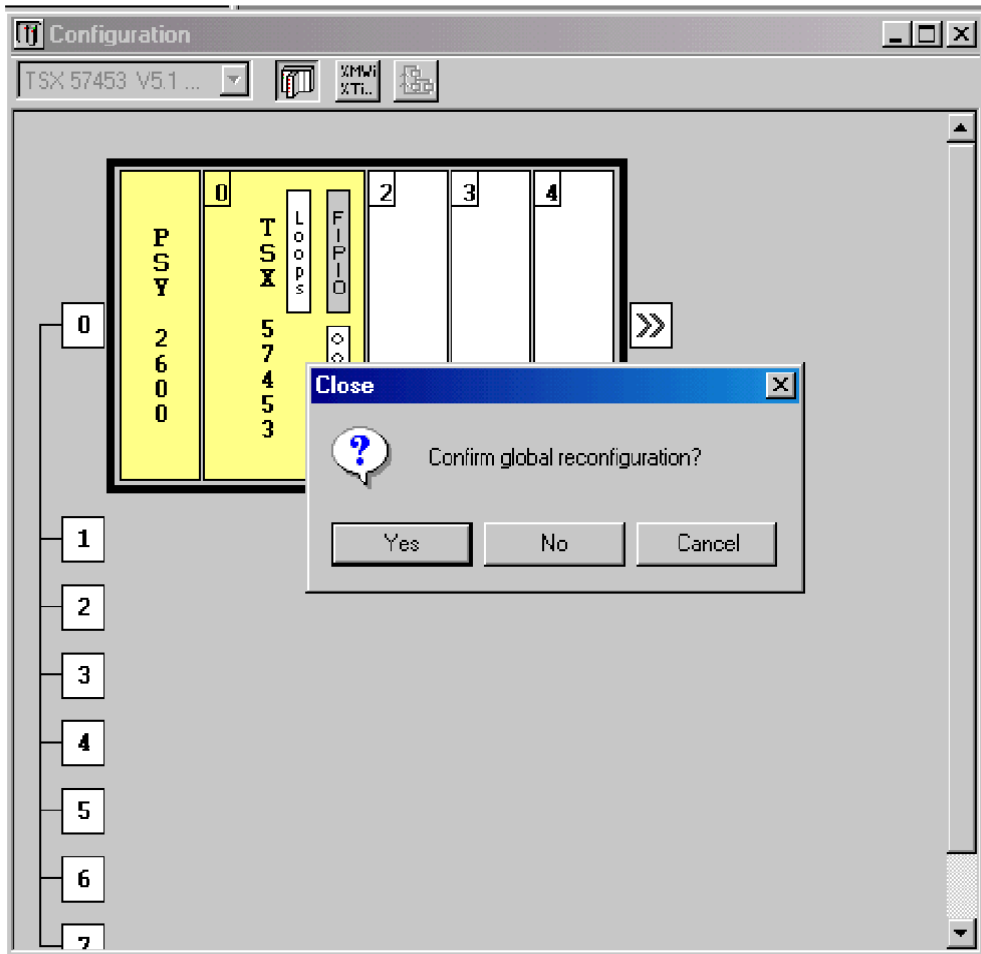

Clicking on **yes** will cause the Fipio network to be reconfigured to integrate the Advantys STB node.

Advanced Configuration Features

5

Introduction

This chapter describes the advanced and/or optional configuration features that you can add to an Advantys STB island.

What's in this Chapter?

This chapter contains the following topics:

Topic	Page
STB NFP 2212 Configurable Parameters	106
Configuring Mandatory Modules	110
Prioritizing a Module	112
What Is a Reflex Action?	113
Island Fallback Scenarios	117
Saving Configuration Data	119
Write-Protecting Configuration Data	120
A Modbus View of the Island's Data Image	121
Predefined Diagnostics Registers in the Data Image	124
The Island's Process Image Blocks	133
An Example of a Modbus View of the Process Image	135
The HMI Blocks in the Island Data Image	143
Test Mode	145
Run-Time Parameters	147
Virtual Placeholder	152

STB NFP 2212 Configurable Parameters

Introduction

The following information describes how to the configure parameters for the STB NFP 2212 using the Advantys configuration software.

The following operating parameters are user configurable:

- data size (in words) of PLC output data transmitted to the HMI panel and HMI input data sent to the PLC
- fieldbus handler control word, used to indicate the size of the data produced by I/O modules on the island bus
- maximum node ID for the last module assembled on the island bus, including CANopen devices

General Information

For general information about the NIM module (model name, version number, vendor code, etc.), do the following:

Step	Action	Comment
1	Open your island configuration with the Advantys configuration software.	The STB NFP 2212 is the leftmost module in your island bus assembly.
2	Double-click on the NIM in the island editor.	The <i>module editor</i> window appears.
3	Select the <i>General</i> tab.	General information about the STB NFP 2212 is displayed.

Accessing Configurable Parameters

To access the configurable parameters for the STB NFP 2212:

Step	Action	Comment
1	Double-click on the STB NFP 2212 in the island editor.	The <i>module editor</i> window appears.
2	Select the <i>Properties</i> tab.	Configurable parameters are located under this tab.
3	In the <i>Parameter name</i> column, expand the <i>NIM parameters list</i> by clicking on the plus (+) sign.	The configurable parameters are displayed.

Selecting the Display Format

By default, the values for the configurable NIM parameters use decimal notation. You can change the display format to hexadecimal notation, and vice-versa:

Step	Action	Comment
1	Double-click the NIM in the island editor.	The <i>module editor</i> window appears.
2	Select the <i>Properties</i> tab.	
3	Click on the checkbox in front of <i>Hexadecimal</i> at the top right of the module editor window. Note: To use decimal notation, again, click on this checkbox to disable hexadecimal notation.	The values for the configurable parameters will display in hexadecimal notation.

Reserved Sizes (HMI to PLC)

The network interprets data from the HMI as input and reads it from the input data table in the process image. This table is shared with data from all input modules on the island bus. When the reserved size (HMI to PLC) is selected, the range of available data sizes (in words) is displayed. Space that you reserve for HMI to PLC data can not exceed a maximum value of 32 words.

Reserved Sizes (PLC to HMI)

The network transmits data to the HMI as output by writing it to the output data table in the process image. This table is shared with data for all output modules on the island bus. When the reserved size (PLC to HMI) is selected, the range of available data sizes (in words) is displayed. Space that you reserve for PLC to HMI data can not exceed a maximum value of 32 words.

Reserving Data Sizes

To transfer data to the PLC from a Modbus HMI panel attached to the CFG port, you must reserve space for that data. To reserve data sizes:

Step	Action	Result
1	In the <i>module editor</i> window, select the <i>Properties</i> tab.	
2	In the <i>Parameter name</i> column, expand the <i>NIM parameters list</i> by clicking on the plus (+) sign.	The configurable NIM parameters are displayed.
3	Double-click in the <i>Value</i> column next to the <i>Reserved Size (Words) of HMI to PLC table</i> .	The value is highlighted.

Step	Action	Result
4	Type a value for the data size to be reserved for data sent from the HMI panel to the PLC.	The value <i>plus</i> the data size of your island cannot exceed the maximum value. If you accept the default value (0), no space will be reserved in the HMI table in the process image.
5	Repeat steps 2-4 to select a value for the <i>Reserved Size (Words) of PLC to HMI table row</i> .	
6	Click on the <i>OK</i> button to save your work.	
7	Click on the <i>Apply</i> button to configure the NIM with these values.	

Fieldbus Handler Control Word Values

The value of the fieldbus handler control word indicates the maximum size (in words) of the data produced by the configuration of I/O modules on your island bus.

The following values are available:

- *auto select (default)*—Accept the default value to have the data size of the island’s I/O modules determined automatically. The appropriate Fipio standard profile will be selected.
- *2 I/O words*—Select this value if your island I/O modules (digital only) produce a maximum of two words of data.
- *8 I/O words*—Select this value if your island I/O modules (digital and analog) produce a maximum of eight words of data.
- *32 I/O words*—Select this value if your island’s I/O modules (digital and analog) produce a maximum of 32 words of data.

The Advantys configuration software automatically associates the data size that you select with the appropriate Fipio standard profile. If the data size that you select is too small to accommodate the data produced by the island I/O modules, you will receive an error message and the *auto select* procedure will be used.

Fieldbus Handler Control Word

To configure the fieldbus handler control word:

Step	Action	Result
1	In the <i>module editor</i> window, select the <i>Properties</i> tab.	
2	In the <i>Parameter name</i> column, expand the <i>NIM parameters list</i> by clicking on the plus (+) sign.	The configurable parameters for the STB NFP 2212 are displayed.
3	Double-click in the <i>Value</i> column next to <i>Fieldbus Handler Control Word</i> .	A drop-down list of data size options is displayed.

Step	Action	Result
4	Select the option that describes the data size of the I/O modules on your island.	See <i>Fieldbus Handler Control Word Values</i> (above).
5	Click on the <i>OK</i> button to save your work.	
6	Click on the <i>Apply</i> button to configure the NIM's data size.	

CANopen Device Node IDs

From the Properties tab, you can set the maximum node ID of the last module on the island bus. The last module may be a standard CANopen device. Standard CANopen devices follow the last segment of STB I/O modules. CANopen modules are addressed by counting backwards from the value that you specify here. The ideal node ID sequence is sequential.

For example, if you have an island with five STB I/O modules and three CANopen devices, a maximum node ID of at least 8 (5 + 3) is required. This will result in node IDs of 1 through 5 for STB I/O modules and 6 through 8 for standard CANopen devices. Using the default ID of 32 (the maximum number of modules the island can support) will result in node IDs of 1 through 5 for STB I/O modules and 30 through 32 for standard CANopen devices. Unless required, high addresses are not desirable if any of your standard CANopen devices has a limited address range.

Assigning the Max. Node ID (CANopen Devices)

To enter the highest node ID used by a CANopen device on the island bus:

Step	Action	Comment
1	In the <i>module editor</i> window, select the <i>Properties</i> tab.	Configurable parameters are located under this tab.
2	In the box next to <i>Max. node ID on the CANopen extension</i> , enter a node ID.	This node ID represents the last CANopen module on the island bus.

Configuring Mandatory Modules

Summary

As part of a custom configuration, you can assign *mandatory* status to any I/O module or preferred device on an island. The mandatory designation indicates that you consider the module or device critical to your application. If the NIM does not detect a healthy mandatory module at its assigned address during normal operations, the NIM stops the entire island.

NOTE: The Advantys Configuration Software is required if you want to designate an I/O module or a preferred device as a mandatory module.

Specifying Mandatory Modules

By default, the Advantys STB I/O modules are in a non-mandatory (*standard*) state. Mandatory status is enabled by clicking on the mandatory checkbox on a module or preferred device's **Options** tab. Depending on your application, any number of modules that your island supports can be designated as mandatory modules.

Effects on Island Bus Operations

The following table describes the conditions under which mandatory modules affect island bus operations and the NIM's response:

Condition	Response
A mandatory module is not operating during normal island bus operations.	The NIM stops the island bus. The island enters fallback mode (<i>see page 117</i>). I/O modules and preferred devices assume their fallback values.
You attempt to hot swap a mandatory module.	The NIM stops the island bus. The island enters fallback mode. I/O modules and preferred devices assume their fallback values.
You are hot swapping a standard I/O module that resides to the left of a mandatory module on the island bus, and the island loses power.	When power is restored, the NIM attempts to address the island modules but must stop at the empty slot where the standard module used to reside. Because the NIM is now unable to address the mandatory module, it generates a mandatory mismatch condition. The island does not start when this condition is present.

Recovering from a Mandatory Stop

WARNING

UNINTENDED EQUIPMENT OPERATION/LOSS OF CONFIGURATION—RST BUTTON WHILE RECOVERING FROM MANDATORY STOP

Pushing the RST button (*see page 61*) causes the island bus to reconfigure itself with factory-default operating parameters, which do not support mandatory I/O status.

- Do not attempt to restart the island by pushing the RST button.
- If a module is unhealthy, replace it with the same module type.

Failure to follow these instructions can result in death, serious injury, or equipment damage.

Pushing the RST button (*see page 61*) while recovering from a mandatory stop loads the island's default configuration data.

Hot Swapping a Mandatory Module

If the NIM has stopped island bus operations because it cannot detect a healthy mandatory module, you can recover island bus operations by installing a healthy module of the same type. The NIM automatically configures the replacement module to match the removed module. Assuming that other modules and devices on the island bus are correctly configured and conform to their configuration data as written to Flash memory, the NIM starts or restarts normal island bus operations. When hot swapping a mandatory module with a Fipio NIM present, the hardware configuration fault bit (x5) in the standard channel status is set. Replacing the module does not clear the bit. To restore normal operations in accordance with Fipio standards, reset the NIM with a reset command from the fieldbus or cycle NIM power.

Prioritizing a Module

Summary

Using the Advantys configuration software, you can assign priority to digital input modules in your island assembly. Prioritization is a method of fine tuning the NIM's I/O scan of the island bus. The NIM will scan modules with priority more frequently than other island modules.

Limitations

You can prioritize only modules with digital inputs. You cannot prioritize output modules or analog modules. You can prioritize only 10 modules for a given island.

What Is a Reflex Action?

Summary

Reflex actions are small routines that perform dedicated logical functions directly on the Advantys island bus. They allow output modules on the island to act on data and drive field actuators directly, without requiring the intervention of the fieldbus master.

A typical reflex action comprises one or two function blocks that perform:

- Boolean AND or exclusive-OR operations
- comparisons of an analog input value to user-specified threshold values
- up- or down-counter operations
- timer operations
- the triggering of a latch to hold a digital value high or low
- the triggering of a latch to hold an analog value at a specific value

The island bus optimizes reflex response time by assigning the highest transmission priority to its reflex actions. Reflex actions take some of the processing workload off the fieldbus master, and they offer a faster, more efficient use of system bandwidth.

How Reflex Actions Behave

WARNING

UNEXPECTED OUTPUT OPERATION

For outputs that are configured to respond to reflex actions, the output state represented in the island's network interface module (NIM) may not represent the actual states of the outputs.

- Turn off field power before you service any equipment connected to the island.
- For digital outputs, view the echo register for the module in the process image to see the actual output state.
- For analog outputs, there is no echo register in the process image. To view an actual analog output value, connect the analog output channel to an analog input channel.

Failure to follow these instructions can result in death, serious injury, or equipment damage.

Reflex actions are designed to control outputs independently of the fieldbus master controller. They may continue to turn outputs on and off even when power is removed from the fieldbus master. Use prudent design practices when you use reflex actions in your application.

Configuring a Reflex Action

Each block in a reflex action must be configured using the Advantys configuration software.

Each block must be assigned a set of inputs and a result. Some blocks also require that you specify one or more user-preset values—a compare block, for example, requires that you preset threshold values and a delta value for hysteresis.

Inputs to a Reflex Action

The inputs to a reflex block include an enable input and one or more operational inputs. The inputs may be constants or they may come from other I/O modules on the island, from virtual modules or outputs from another reflex block. For example, an XOR block requires three inputs—the enable and two digital inputs that contain the Boolean values to be XORed:

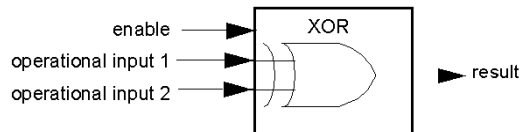

Some blocks, such as the timers, require reset and/or trigger inputs to control the reflex action. The following example shows a timer block with three inputs:

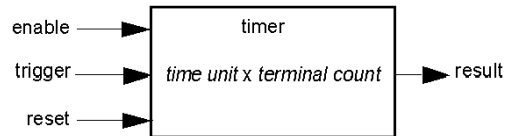

The trigger input starts the timer at 0 and accumulates *time units* of 1, 10, 100 or 1000 ms for a specified number of counts. The reset input causes the timer accumulator to be reset.

An input to a block may be a Boolean value, a word value, or a constant, depending on the type of reflex action it is performing. The enable input is either a Boolean or a constant *always enabled* value. The operational input to a block such as a digital latch must always be a Boolean, whereas the operational input to an analog latch must always be a 16-bit word.

You will need to configure a source for the block's input values. An input value may come from an I/O module on the island or from the fieldbus master via a virtual module in the NIM.

NOTE: All inputs to a reflex block are sent on a change-of-state basis. After a change-of-state event has occurred, the system imposes a 10 ms delay before it accepts another change of state (input update). This feature is provided to minimize jitter in the system.

Result of a Reflex Block

Depending on the type of reflex block that you use, it will output either a Boolean or a word as its result. Generally, the result is mapped to an *action module*, as shown in the following table:

Reflex Action	Result	Action Module Type
Boolean logic	Boolean value	digital output
integer compare	Boolean value	digital output
counter	16-bit word	first block in a nested reflex action
timer	Boolean value	digital output
digital latch	Boolean value	digital output
analog latch	16-bit word	analog output

The result from a block is usually mapped to an individual channel on an output module. Depending on the type of result that the block produces, this action module may be an analog channel or a digital channel.

When the result is mapped to a digital or analog output channel, that channel becomes dedicated to the reflex action and can no longer use data from the fieldbus master to update its field device.

The exception is when a reflex block is the first of two actions in a nested reflex action.

Nesting

The Advantys configuration software allows you to create nested reflex actions. One level of nesting is supported—i.e., two reflex blocks, where the result of the first block is an operational input to the second block.

When you nest a pair of blocks, you need to map the results of both to the same action module. Choose the action module type that is appropriate for the result of the second block. This may mean that in some cases you will need to choose an action module for the first result that does not seem to be appropriate according to the table above.

For example, say you want to combine a counter block and a compare block in a nested reflex action. You want the result of the counter to be the operational input to the compare block. The compare block will then produce a Boolean as its result:

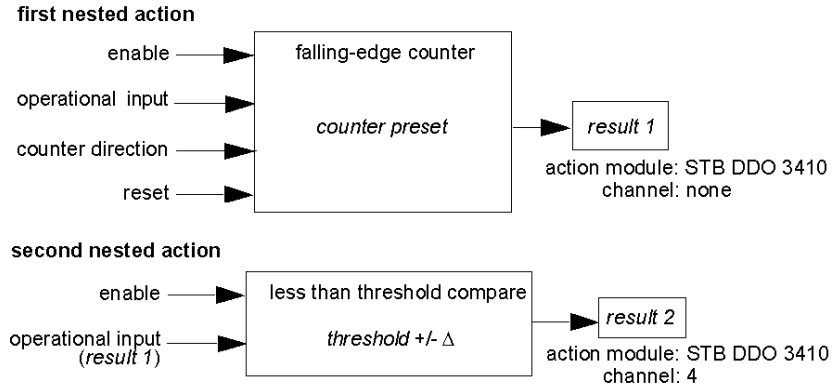

Result 2 (from the compare block) is the result that the nested reflex action will send to an actual output. Because the result of a compare block needs to be mapped to a digital action module, *result 2* is mapped to channel 4 on an STB DDO 3410 digital output module.

Result 1 is used only inside the module—it provides the 16-bit operational input to the compare block. It is mapped to the same STB DDO 3410 digital output module that is the action module for the compare block.

Instead of specifying a physical channel on the action module for *result 1*, the channel is set to *none*. In effect, you are sending *result 1* to an internal reflex buffer where it is stored temporarily until it is used as the operational input to the second block. You are not really sending an analog value to a digital output channel.

Number of Reflex Blocks on an Island

An island can support up to 10 reflex blocks. A nested reflex action consumes two blocks.

An individual output module can support up to two reflex blocks. Supporting more than one block requires that you manage your processing resources efficiently. If you are not careful with your resources, you may be able to support only one block on an action module.

Processing resources are consumed quickly when a reflex block receives its inputs from multiple sources (different I/O modules on the island and/or virtual modules in the NIM). The best way to preserve processing resources is to:

- use the *always enabled* constant as the enable input whenever possible
- use the same module to send multiple inputs to a block whenever possible

Island Fallback Scenarios

Introduction

In the event of a communications interruption on the island or between the island and the fieldbus, output data is put into a fallback state. In this state, output data is replaced with pre-configured fallback values. This makes known the module's output data values when the system recovers from this condition.

Fallback Scenarios

There are several scenarios in which Advantys STB output modules go into their fallback states:

- loss of fieldbus communications: Communications with the PLC are lost.
- loss of island bus communications: There is an internal island bus communications interruption, indicated by a missing heartbeat message from either the NIM or a module.
- change of operating state: The NIM may command the island I/O modules to switch from a running to a non-running (stopped or reset) state.
- missing or non-operating mandatory module: The NIM detects this condition for a mandatory island module.

NOTE: If a mandatory (or any other) module is not operating, it needs to be replaced. The module itself does not go into its fallback state.

In all of these fallback scenarios, the NIM disables the heartbeat message.

Heartbeat Message

The Advantys STB system relies on a heartbeat message to verify the integrity and continuity of communications between the NIM and the island modules. The health of island modules and the overall integrity of the Advantys STB system are monitored through the transmission and reception of these periodic island bus messages.

Because island I/O modules are configured to monitor the NIM's heartbeat message, output modules go into their fallback states if they do not receive a heartbeat message from the NIM within the defined interval.

Fallback States for Reflex Functions

Only an output module channel to which the result of a reflex action (*see page 113*) has been mapped can operate in the absence of the NIM's heartbeat message.

When modules that provide input for reflex functionality are not operating or are removed from the island, the channels that hold the result of those reflex actions go into their fallback states.

In most cases, an output module that has one of its channels dedicated to a reflex action goes to its configured fallback state if the module loses communication with the fieldbus master. The only exception is a two-channel digital output module that has both of its channels dedicated to reflex actions. In this case, the module may continue to solve logic after a loss of fieldbus communication. For more information about reflex actions, refer to the *Reflex Actions Reference Guide*.

Configured Fallback

To define a customized fallback strategy for individual modules, you are required to use the Advantys Configuration Software. Configuration is done channel by channel. You can configure a single module's multiple channels with different fallback parameters. Configured fallback parameters (implemented only during a communications interruption) are part of the configuration file stored in the NIM's non-volatile Flash memory.

Fallback Parameters

You can select either of two fallback modes when configuring output channels with the Advantys Configuration Software:

- *hold last value*: In this mode, outputs retain the last values they were assigned before the fallback condition was triggered.
- *predefined value*: In this (default) mode, you can select either of two fallback values:
 - 0 (default)
 - some value in acceptable range

The permissible values for fallback parameters in the *predefined value* mode for discrete and analog modules and reflex functions appear in the following table:

Module Type	Fallback Parameter Values
discrete	0/off (default)
	1/on
analog	0 (default)
	not 0 (in range of acceptable analog values)

NOTE: In an auto-configured system, default fallback parameters and values are always used.

Saving Configuration Data

Introduction

The Advantys configuration software allows you to save configuration data created or modified with this software to the NIM's Flash memory and/or to the removable memory card (*see page 55*). Subsequently, this data can be read from Flash memory and used to configure your physical island.

NOTE: If your configuration data is too large, you will receive a message when you attempt to save it.

How to Save a Configuration

The following procedure describes the steps you use to save a configuration data file to Flash memory directly and to a removable memory card. For more detailed procedural information, use the configuration software's online help feature:

Step	Action	Comment
1	Connect the device running the Advantys Configuration Software to the CFG port (<i>see page 38</i>) on the NIM.	For NIM modules that support Ethernet communications, you can connect the device directly to the Ethernet port.
2	Launch the configuration software.	
3	Download the configuration data that you want to save from the configuration software to the NIM.	A successful download saves the configuration data to the NIM's flash memory.
4	Install the card (<i>see page 56</i>) in the host NIM, then use the Store to SIM card command.	Saving the configuration data to the removable memory card is optional. This operation overwrites old data on the SIM card.

Write-Protecting Configuration Data

Introduction

As part of a custom configuration, you can password-protect an Advantys STB island. Only authorized persons have write privileges to the configuration data currently stored in Flash memory:

- Use the Advantys Configuration Software to password-protect an island's configuration.
- For some modules, it is possible to password-protect the island configuration through an embedded web site.

The island runs normally in protected mode. All users have the ability to monitor (read) the activity on the island bus. If a configuration is write-protected, access to it is restricted in the following ways:

- An unauthorized user is unable to overwrite the current configuration data in Flash memory.
- The RST button (*see page 61*) is disabled, and pushing it has no effect on island bus operations.
- The presence of a removable memory card (*see page 55*) is ignored. The configuration data currently stored in Flash cannot be overwritten by data on the card.

NOTE: The STB NIP 2311 NIM never ignores the removable memory card.

Password Characteristics

A password must meet the following criteria:

- It must be between 0 and 6 characters in length.
- Only alphanumeric ASCII characters are permitted.
- The password is case-sensitive.

If password protection is enabled, your password is saved to Flash memory (or to a removable memory card) when you save the configuration data.

NOTE: A password-protected configuration is inaccessible to anyone who does not know the password. Your system administrator is responsible for keeping track of the password and the list of authorized users. If the assigned password is lost or forgotten, you are unable to change the island's configuration.

If the password is lost and you need to reconfigure the island, you need to perform a destructive reflash of the NIM. This procedure is described on the Advantys STB product Web site at www.schneiderautomation.com.

A Modbus View of the Island's Data Image

Summary

A block of Modbus registers is reserved in the NIM to hold and maintain the island's data image. Overall, the data image holds 9999 registers. The registers are divided into contiguous groups (or blocks), each dedicated to a specific purpose.

Modbus Registers and Their Bit Structure

Registers are 16-bit constructs. The most significant bit (MSB) is bit 15, which is displayed as the leftmost bit in the register. The least significant bit (LSB) is bit 0, displayed as the rightmost bit in the register:

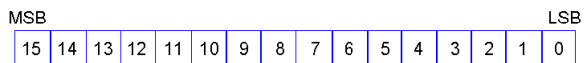

The bits can be used to display operating data or device/system status.

Each register has a unique reference number, starting at 40001. The content of each register, represented by its 0/1 bit pattern, may be dynamic, but the register reference and its assignment in the control logic program remain constant.

The Data Image

The 9999 contiguous registers in the Modbus data image start at register 40001. This figure shows the subdivision of data into sequential blocks:

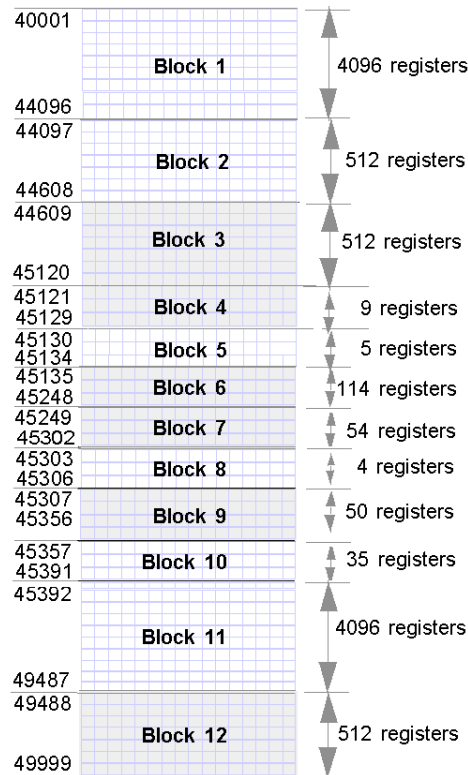

- Block 1** output data process image (4096 registers available)
- Block 2** fieldbus master-to-HMI output table (512 registers available)
- Block 3** reserved (512 registers available)
- Block 4** 9-register block reserved for future read/write use
- Block 5** 5-register RTP Request Block
- Block 6** 114-register block reserved for future read/write use
- Block 7** 54-register block reserved for future read/write use
- Block 8** 4-register RTP Response Block
- Block 9** 50-register block reserved for future read-only use
- Block 10** 35 predefined island bus status registers
- Block 11** input data/status process image (4096 registers available)
- Block 12** HMI-to-fieldbus master input table (512 registers available)

Each block has a fixed number of registers reserved for its use. Whether or not all the registers reserved for that block are used in an application, the number of registers allocated to that block remains constant. This permits you to know at all times where to begin looking for the type of data of interest to you.

For example, to monitor the status of the I/O modules in the process image, look at the data in block 11 beginning at register 45392.

Reading Register Data

All the registers in the data image can be read by an HMI panel connected to the island at the NIM's CFG port (*see page 38*). The Advantys configuration software reads all this data, and displays blocks 1, 2, 5, 8, 10, 11, and 12 in the Modbus Image screen in its I/O Image Overview.

Writing Register Data

Some registers, usually configured number of registers in block 12 (registers 49488 through 49999) of the data image, may be written to by an HMI panel (*see page 143*).

The Advantys configuration software or an HMI panel may also be used to write data to the registers in block 1 (registers 40001 through 44096). The configuration software or the HMI panel must be the island bus master in order for it to write to the data image—i.e., the island must be in *test* mode.

Predefined Diagnostics Registers in the Data Image

Summary

Thirty-five contiguous registers (45357 through 45391) in the island bus data image (*see page 122*) are provided for reporting diagnostic information. These registers have predefined meanings that are described below. They can be accessed and monitored through an HMI panel or by the Advantys configuration software.

Island Communications Status

Register 45357 describes the state of communications across the island bus. The low byte (bits 7 through 0) displays one of 15 possible eight-bit patterns that indicates the current state of communication. Each bit in the high byte (bits 15 through 8) is used to signal the presence or absence of a specific error condition.

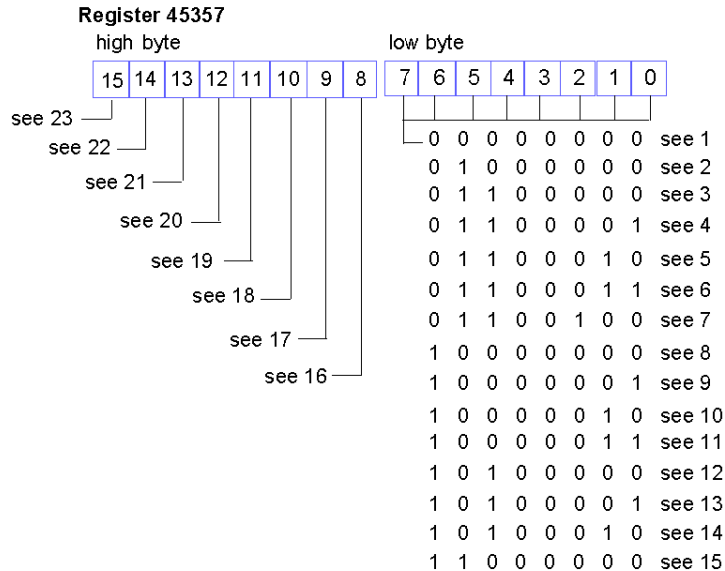

- 1 The island is initializing.
- 2 The island has been set to pre-operational mode, for example, by the reset function.
- 3 The NIM is configuring or auto-configuring—communication to all modules is reset.
- 4 The NIM is configuring or auto-configuring—checking for any modules that are not auto-addressed.
- 5 The NIM is configuring or auto-configuring—Advantys STB and preferred modules are being auto-addressed.
- 6 The NIM is configuring or auto-configuring—boot-up is in progress.
- 7 The process image is being set up.

- 8 Initialization is complete, the island bus is configured, the configuration matches, and the island bus is not started.
- 9 Configuration mismatch—non-mandatory or unexpected modules in the configuration do not match, and the island bus is not started.
- 10 Configuration mismatch—at least one mandatory module does not match, and the island bus is not started.
- 11 Serious configuration mismatch—the island bus has been set to pre-operational mode, and initialization is aborted.
- 12 The configuration matches, and the island bus is operational.
- 13 The island is operational with a configuration mismatch. At least one standard module does not match, but all the mandatory modules are present and operating.
- 14 Serious configuration mismatch—the island bus was started but is now in pre-operational mode because of one or more mismatched mandatory module(s).
- 15 The island has been set to pre-operational mode, for example, by the stop function.
- 16 A value of 1 in bit 8 is a fatal error. It indicates a low-priority receive queue software overrun error.
- 17 A value of 1 in bit 9 is a fatal error. It indicates a NIM overrun error.
- 18 A value of 1 in bit 10 indicates an island bus-off error.
- 19 A value of 1 in bit 11 is a fatal error. It indicates that the error counter in the NIM has reached the warning level and the error status bit has been set.
- 20 A value of 1 in bit 12 indicates that the NIM's error status bit has been reset.
- 21 A value of 1 in bit 13 is a fatal error. It indicates a low-priority transfer queue software overrun error.
- 22 A value of 1 in bit 14 is a fatal error. It indicates a high-priority receive queue software overrun error.
- 23 A value of 1 in bit 15 is a fatal error. It indicates a high-priority transfer queue software overrun error.

Error Reporting

Each bit in register 45358 is used to report a global error condition. A value of 1 in the bit indicates that a specific global error has been detected.

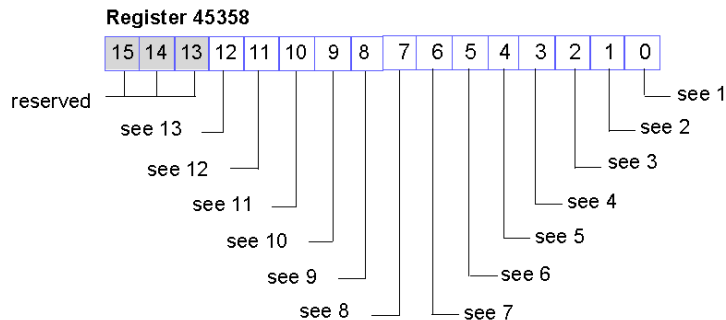

- 1 Fatal error. Because of the severity of the error, no further communications are possible on the island bus.

- 2 Module ID error—A standard CANopen device is using a module ID reserved for the Advantys STB modules.
- 3 Auto-addressing has failed.
- 4 Mandatory module configuration error.
- 5 Process image error—either the process image configuration is inconsistent, or it could not be set up during auto-configuration.
- 6 Auto-configuration error—a module is not in its configured location, and the NIM cannot complete auto-configuration.
- 7 An island bus management error was detected by the NIM.
- 8 Assignment error—the initialization process in the NIM has detected a module assignment error, possibly the result of at least one application parameter mismatch.
- 9 Internal triggering protocol error.
- 10 Module data length error.
- 11 Module configuration error.
- 12 Application parameter error.
- 13 Application parameter services or timeout error.

Node Configuration

The next eight contiguous registers (registers 45359 through 45366) display locations where modules have been configured on the island bus. This information is stored in Flash memory. At start up, the actual locations of the modules on the island are validated by comparing them to the configured locations stored in memory. Each bit represents a configured location:

- A value of 1 in a bit indicates that a module has been configured for the associated location.
- A value of 0 in a bit indicates that a module has not been configured for the associated location.

The first two registers, shown below, provide the 32 bits that represent the module locations available in a typical island configuration. The remaining six registers (45361 through 45366), are available to support the island's expansion capabilities.

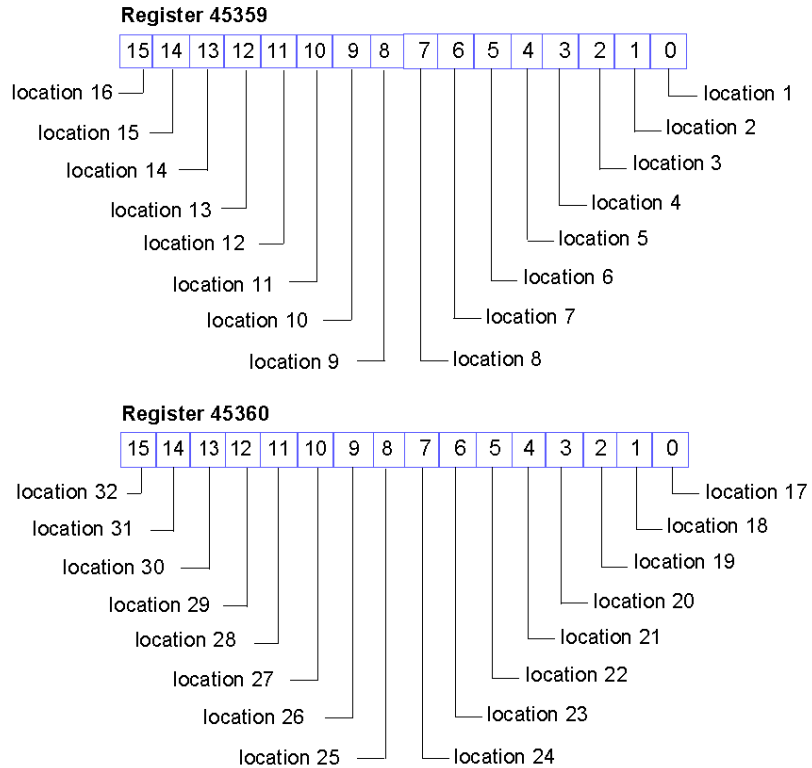

Node Assembly

The next eight contiguous registers (registers 45367 through 45374) indicate the presence or absence of configured modules in locations on the island bus. This information is stored in Flash memory. At start up, the actual locations of the modules on the island are validated by comparing them to the configured locations stored in memory. Each bit represents a module:

- A value of 1 in a given bit indicates either that the configured module is not present or that the location has not been configured.
- A value of 0 indicates that the correct module is present in its configured location.

The first two registers, shown below, provide the 32 bits that represent the module locations available in a typical island configuration. The remaining six registers (45369 through 45374) are available to support the island's expansion capabilities.

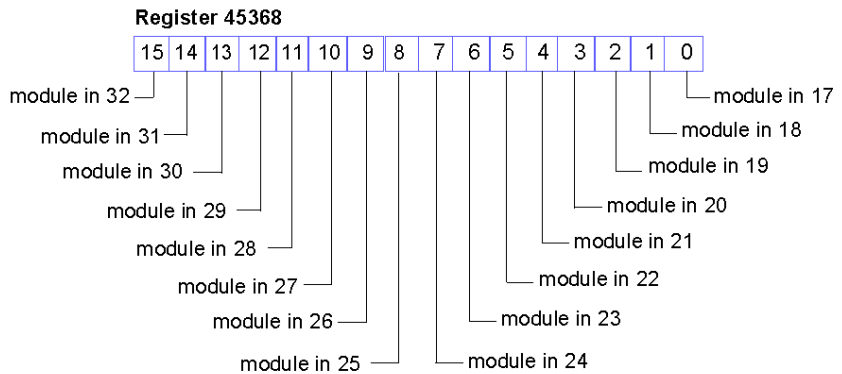
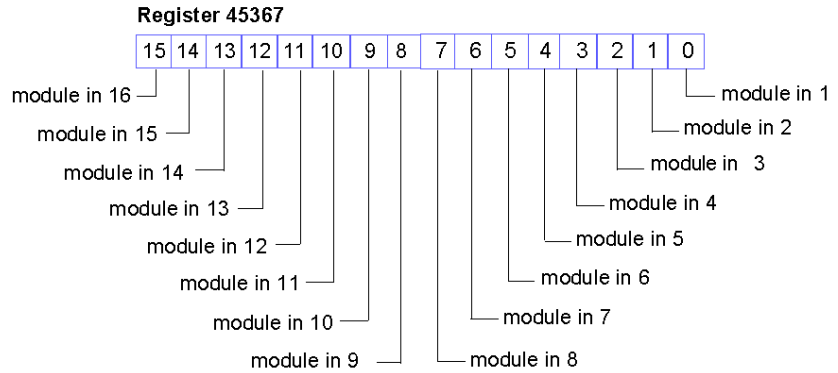

Emergency Messages

The next eight contiguous registers (registers 45375 through 45382) indicate the presence or absence of newly received emergency messages for individual modules on the island. Each bit represents a module:

- A value of 1 in a given bit indicates that a new emergency message has been queued for the associated module.
- A value of 0 in a given bit indicates that no new emergency messages have been received for the associated module since the last time the diagnostic buffer was read.

The first two registers, shown below, provide the 32 bits that represent the module locations available in a typical island configuration. The remaining six registers (45377 through 45382) are available to support the island's expansion capabilities.

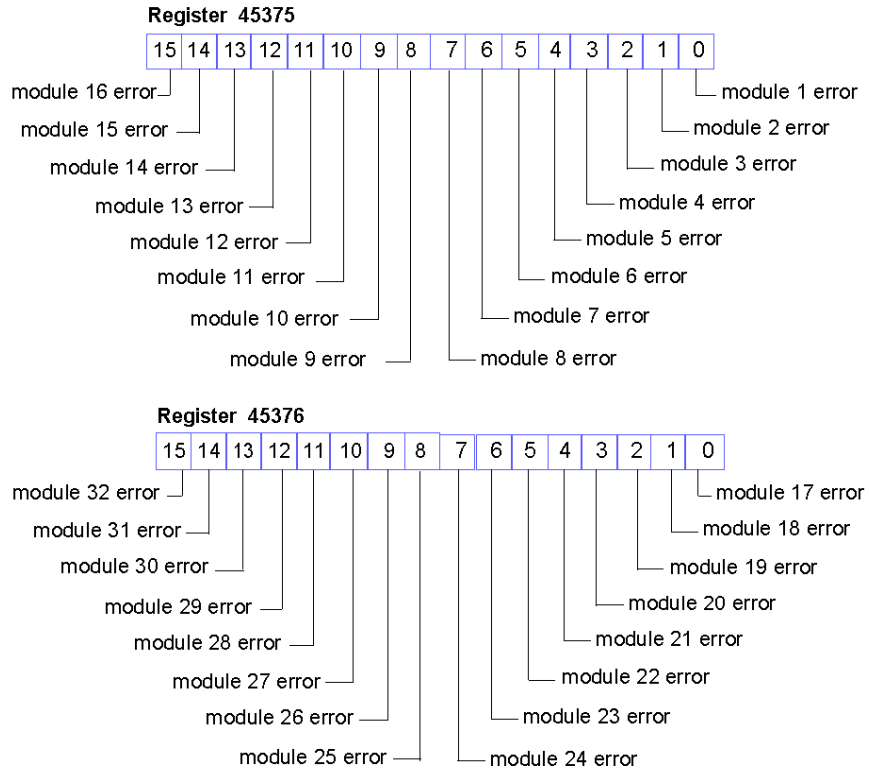

Fault Detection

The next eight contiguous registers (registers 45383 through 45390) indicate the presence or absence of operational faults detected on the island bus modules. Each bit represents a module:

- A value of 1 in a bit indicates that the associated module is operating and that no faults were detected.
- A value of 0 in a bit indicates that the associated module is not operating either because it has a fault or because it has not been configured.

The first two registers, shown below, provide the 32 bits that represent the module locations available in a typical island configuration. The remaining six registers (45385 through 45390) are available to support the island's expansion capabilities.

Register 45383

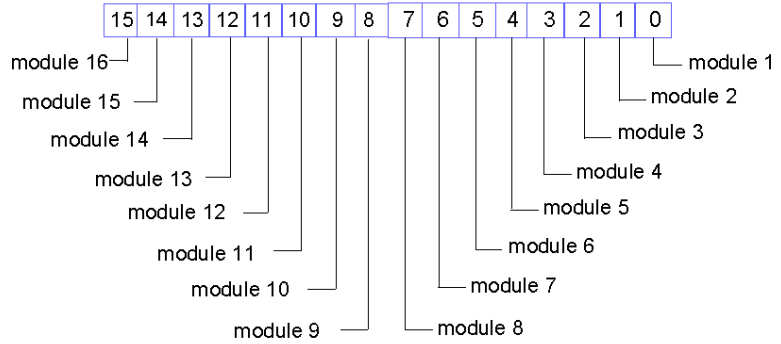

Register 45384

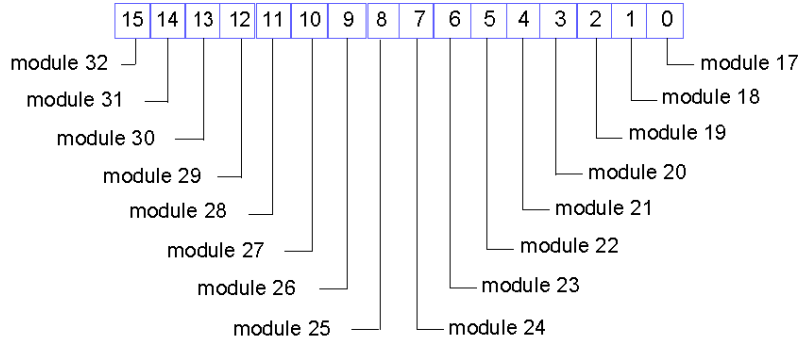

NIM Status

The eight LSBs (bits 7 through 0) in register 45391 report the status of the NIM. Note that the four bits bits 0 through 3 (*see page 132*) together represent the current operational state of the STB NFP 2212.

Register 45391

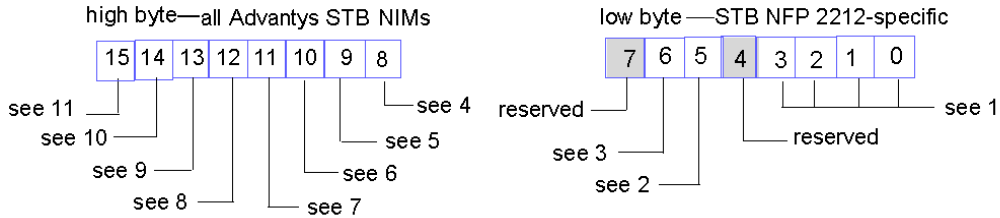

- 1 The value of bits 0—3 represent the current state of the NIM.
- 2 A value of 1 in bit 5 indicates an invalid node address.
- 3 A value of 1 in bit 6 indicates that the Fipio standard profile type created with the Advantys configuration software is smaller than the actual island bus assembly and is ignored. The standard profile type determined by auto-addressing is adopted and saved in the NIM's Flash memory.
- 4 Module failure—bit 8 is set to 1 if any module on the island bus fails.
- 5 A value of 1 in bit 9 indicates an internal failure—at least one global bit was set.
- 6 A bit value of 1 in bit 10 indicates an external failure—the problem is on the fieldbus.
- 7 A value of 1 in bit 11 indicates that the configuration is protected—the RST button is disabled, and the island configuration requires a password to write to it; a bit value of 0 indicates that the island configuration is unprotected—the RST button is enabled, and the configuration is not password-protected.
- 8 A value of 1 in bit 12 indicates that the configuration on the removable memory card is invalid.
- 9 A value of 1 in bit 13 indicates that reflex action functionality has been configured. (For NIMs with firmware version 2.0 or greater.)
- 10 A value of 1 in bit 14 indicates that one or more island modules have been hot-swapped. (For NIMs with firmware version 2.0 or greater.)
- 11 Island bus output data master—a value of 0 in bit 15 indicates that the fieldbus master device is controlling the output data of the island's process image; a bit value of 1 indicates that the Advantys configuration software is controlling the output data of the island's process image.

Operational States of the STB NFP 2212

Bits 0 through 3 in register 45391 (*see page 131*) use the values in the following table to indicate the current operational state of the STB NFP 2212:

STB NFP 2212 operational state	bit 3	bit 2	bit 1	bit 0
island configuration check	0	0	0	0
initialization of STB NFP 2212 Fipio handler	0	0	0	1
data exchange	0	0	1	0
fault checking	0	0	1	1

The Island's Process Image Blocks

Summary

Two blocks of registers in the island's data image (*see page 122*) are the focus for this discussion. The first block is the output data process image, which starts at register 40001 and goes to register 44096. The other block is the input data and I/O status process image, which also consumes 4096 registers (45392 through 49487). The registers in each block are used to report island bus device status and to dynamically exchange input or output data between the fieldbus master and the island's I/O modules.

Output Data Process Image

The output data block (registers 40001 through 44096) handles the output data process image. This process image is a Modbus representation of the control data that has just been written from the fieldbus master to the NIM. Only data for the island's output modules is written to this block.

Output data is organized in 16-bit register format. One or more registers are dedicated to the data for each output module on the island bus.

For example, say you are using a two-channel digital output module as the first output module on your island bus. Output 1 is on and output 2 is off. This information would be reported in the first register in the output data process image, and it would look like this:

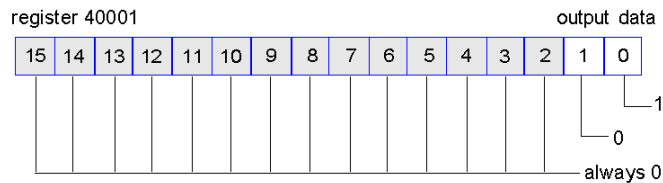

where:

- Normally, a value of 1 in bit 0 indicates that output 1 is on.
- Normally, a value of 0 in bit 1 indicates that output 2 is off.
- The remaining bits in the register are not used.

Some output modules, such as the one in the example above, utilize a single data register. Others may require multiple registers. An analog output module, for example, would use separate registers to represent the values for each channel, and might use the 11 or 12 most significant bits to display analog values in IEC format.

Registers are allocated to output modules in the output data block according to their addresses on the island bus. Register 40001 always contains the data for the first output module on the island (the output module closest to the NIM).

Output Data Read/Write Capabilities

The registers in the output data process image are read/write-capable.

You can read (i.e., monitor) the process image using an HMI panel or the Advantys Configuration Software. The data content that you see when you monitor the output data image registers is updated in near-real time.

The island's fieldbus master also writes updated control data to the output data process image.

Input Data and I/O Status Process Image

The input data and I/O status block (registers 45392 through 49487) handles the input data and I/O status process image. Every I/O module on the island bus has information that needs to be stored in this block.

- Each digital input module reports data (the on/off status of its input channels) in one register of input data and I/O status block, then reports its status in the next register.
- Each analog input module uses four registers in the input data and I/O status block. It represents the analog data for each channel in separate registers and the status of each channel in separate registers. Analog data is usually represented with 11- or 12-bit resolution in the IEC format; status in an analog input channel is usually represented by a series of status bits that report the presence or absence of an out-of-range value in a channel.
- Each digital output module reports an echo of its output data to a register in the input data and I/O status block. Echo output data registers are essentially copies of the register values that appear in the output data process image. This data is usually not of much interest, but it can be useful in the event that a digital output channel has been configured for a reflex action. In this case, the fieldbus master can see the bit value in the echo output data register even though the output channel is being updated inside the island bus.
- Each analog output module uses two registers in the input data and I/O status block to report status. Status in an analog output channel is usually represented by a series of status bits that report the presence or absence of an out-of-range value in a channel. Analog output modules do not report data in this block.

A detailed view of how the registers in the input data and I/O status block are implemented is shown in the process image example.

An Example of a Modbus View of the Process Image

Summary

The following example shows what the output data process image and the input data and I/O status process image might look like when it represents a specific island bus configuration.

The Sample Configuration

The sample island comprises the following 10 modules and a termination plate:

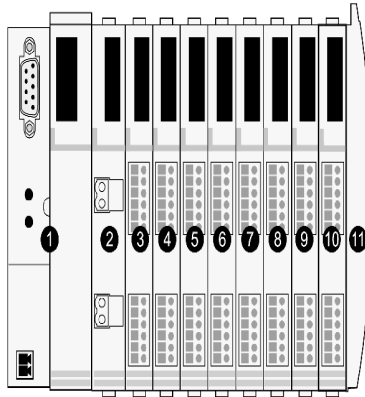

- 1 network interface module
- 2 24 VDC power distribution module
- 3 STB DDI 3230 24 VDC two-channel digital input module
- 4 STB DDO 3200 24 VDC two-channel digital output module
- 5 STB DDI 3420 24 VDC four-channel digital input module
- 6 STB DDO 3410 24 VDC four-channel digital output module
- 7 STB DDI 3610 24 VDC six-channel digital input module
- 8 STB DDO 3600 24 VDC six-channel digital output module
- 9 STB AVI 1270 +/-10 VDC two-channel analog input module
- 10 STB AVO 1250 +/-10 VDC two-channel analog output module
- 11 STB XMP 1100 island bus termination plate

The I/O modules have the following island bus addresses (*see page 52*):

I/O Model	Module Type	Island Bus Address
STB DDI 3230	two-channel digital input	1
STB DDO 3200	two-channel digital output	2
STB DDI 3420	four-channel digital input	3
STB DDO 3410	four-channel digital output	4
STB DDI 3610	six-channel digital input	5

I/O Model	Module Type	Island Bus Address
STB DDO 3600	six-channel digital output	6
STB AVI 1270	two-channel analog input	7
STB AVO 1250	two-channel analog output	8

The PDM and the termination plate do not consume island bus addresses and are not represented in the process image.

The Output Data Process Image

Let's look first at the register allocation required to support the output data process image (*see page 133*). This is the data written to the island from the fieldbus master to update the output modules on the island bus. The four output modules are affected—the three digital output modules at addresses 2, 4, and 6 and the one analog output module at address 8.

The three digital output modules utilize one Modbus register apiece for data. The analog output module requires two registers, one for each output channel. A total of five registers (registers 40001 through 40005) are used for this configuration:

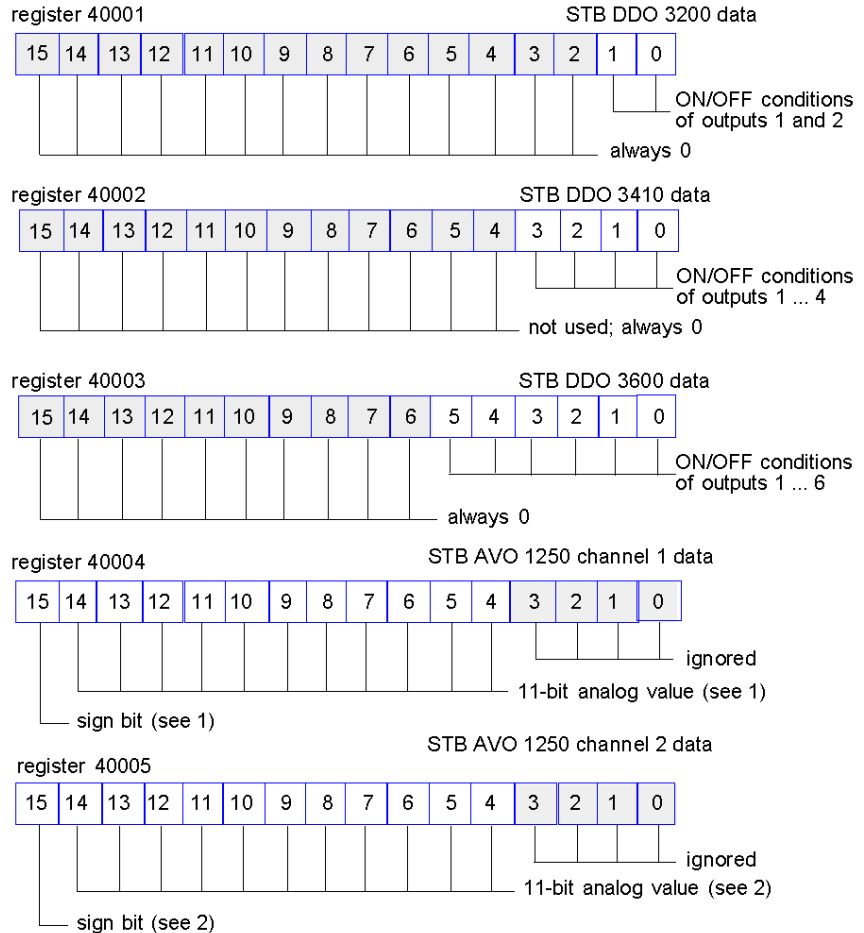

- 1 The value represented in register 40004 is in the range +10 to -10 V, with 11-bit resolution plus a sign bit in bit 15.
- 2 The value represented in register 40005 is in the range +10 to -10 V, with 11-bit resolution plus a sign bit in bit 15.

The digital modules use the LSBs to hold and display their output data. The analog module uses the MSBs to hold and display its output data.

The Input Data and I/O Status Process Image

Now let's look at the register allocation required to support the input data and I/O status process image (*see page 134*). This is the information that the NIM collects from the island modules so that it can be read by the fieldbus master or by some other monitoring device.

All eight I/O modules are represented in this process image block. The modules are assigned registers in the order of their island bus addresses, starting at register 45392.

Each digital I/O module uses two contiguous registers:

- Digital input modules use one register to report data and the next to report status.
- Digital output modules use one register to echo output data and the next to report status.

NOTE: The value in an *echo output data* register is basically a copy of the value written to the corresponding register in the output data process image. Generally, this is the value written to the NIM by the fieldbus master, and its echo is of not much interest. When an output channel is configured to perform a reflex action (*see page 113*), however, the echo register provides a location where the fieldbus master can look to see the current value of the output.

The analog input module uses four contiguous registers:

- the first register to report the data for channel 1
- the second register to report status for channel 1
- the third register to report the data for channel 2
- the fourth register to report status for channel 2

The analog output module uses two contiguous registers:

- the first register to report status for channel 1
- the second register to report status for channel 2

In total, 18 registers (registers 45392 through 45409) are used to support our configuration:

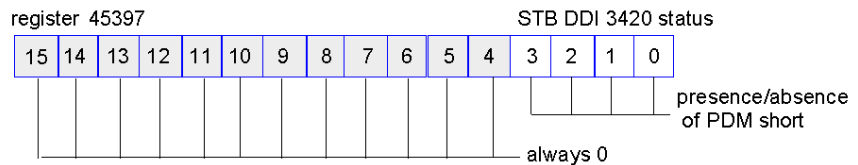
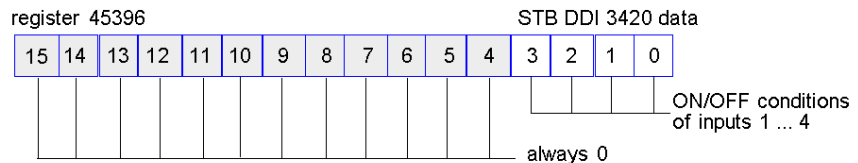
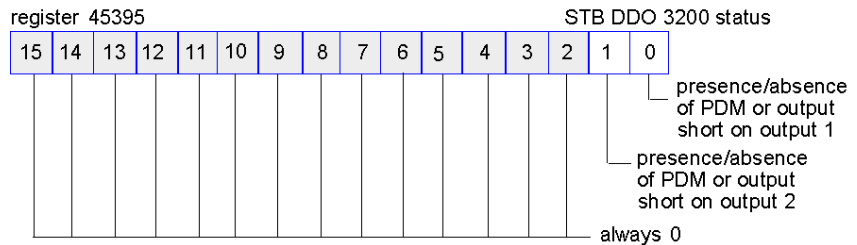
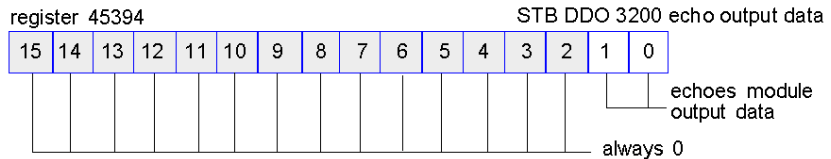
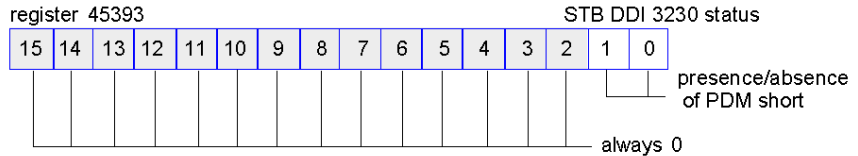
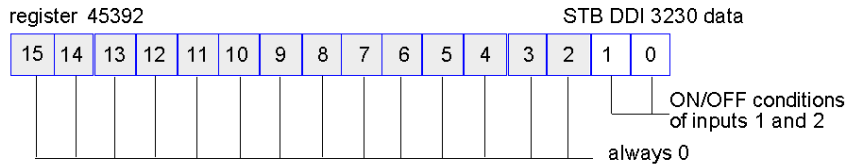

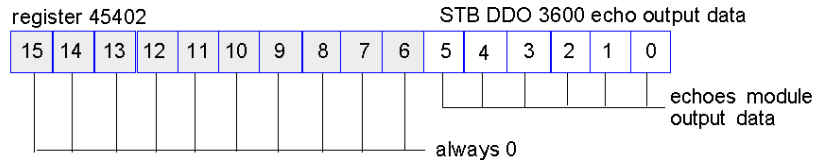
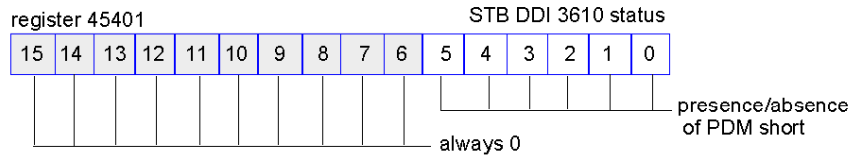
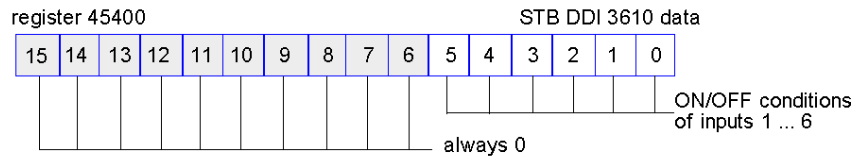
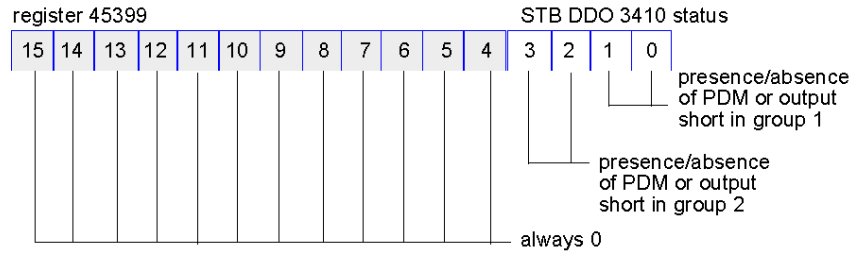
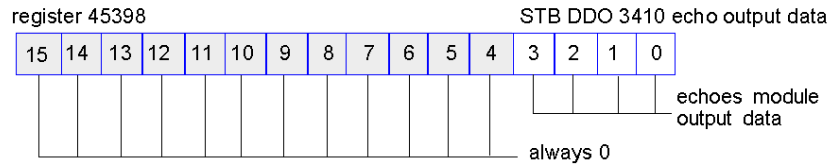

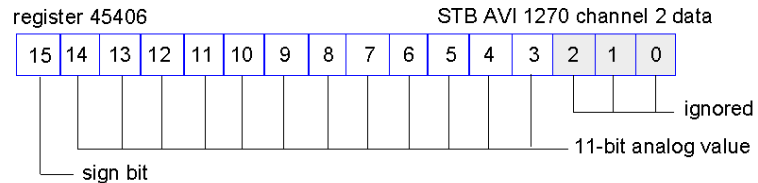
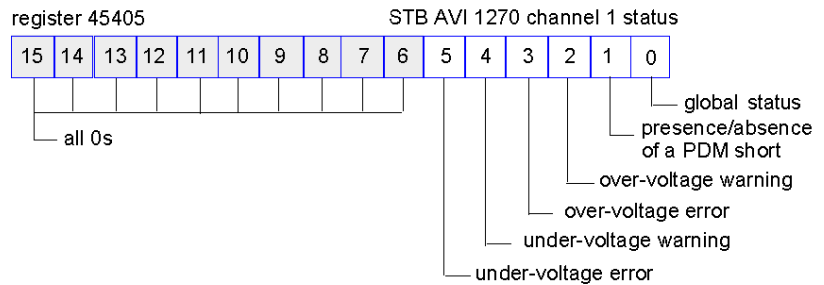
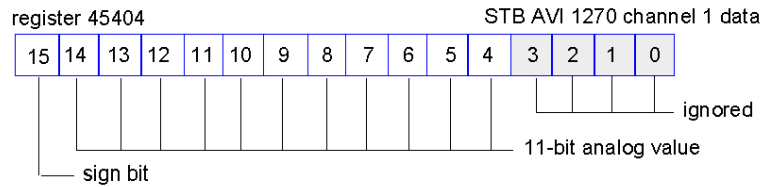
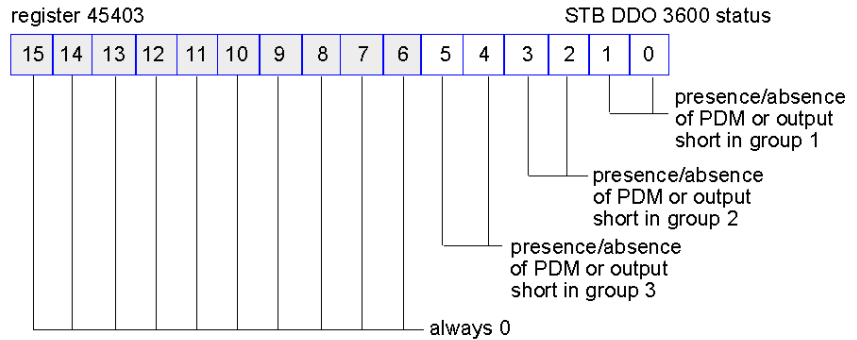

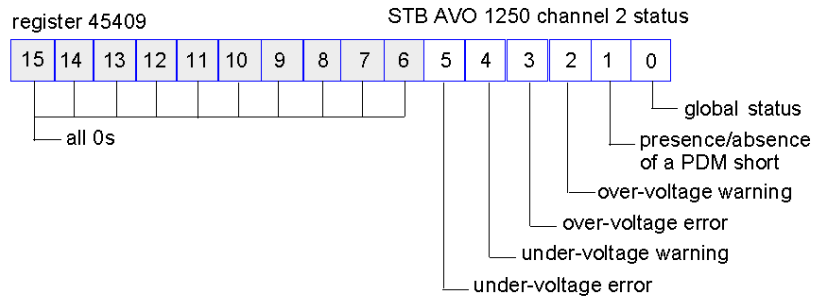
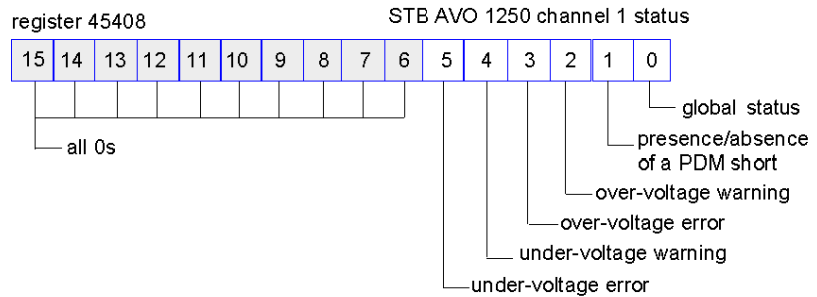
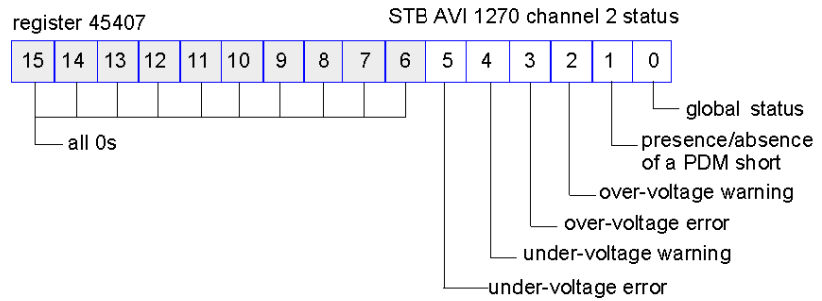

The HMI Blocks in the Island Data Image

Summary

An HMI panel that communicates using the Modbus protocol can be connected to the CFG port (*see page 38*) on the NIM. Using the Advantys configuration software, you can reserve one or two blocks of registers in the data image (*see page 121*) to support HMI data exchange. When an HMI panel writes to one of these blocks, that data is accessible to the fieldbus master (as inputs). Data written by the fieldbus master (as outputs) is stored in a different reserved block of registers that the HMI panel can read.

HMI Panel Configuration

Advantys STB supports the ability of an HMI panel to act as:

- an input device, which writes data to the island's data image that is read by the fieldbus master
- an output device, which can read data written by the fieldbus master to the island's data image
- a combined I/O device

HMI Input Data Exchange

Input data to the fieldbus master can be generated by the HMI panel. Input controls on an HMI panel might be elements such as:

- push buttons
- switches
- a data entry keypad

To use an HMI panel as an input device on the island, you need to enable the HMI-to-fieldbus master block in the island's data image (*see page 122*) and specify the number of registers in this block that you want to use for HMI-to-fieldbus master data transfers. You must use the Advantys configuration software to make these configuration adjustments.

The HMI-to-fieldbus master block can comprise up to 512 registers, ranging from register 49488 to 49999. (Your actual register limit will be dictated by your fieldbus.) This block follows immediately after the standard input data and I/O status process image (*see page 134*) block (registers 45392 through 49487) in the island's data image.

The HMI panel writes the input data to a specified number of registers in the HMI-to-fieldbus master block. The NIM manages the transfer of the HMI data in these registers as part of the overall input data transfer—it converts the 16-bit register data to a fieldbus-specific data format and transfers it together with the standard input data and I/O status process image to the fieldbus. The fieldbus master sees and responds to HMI data as if it were standard input data.

HMI Output Data Exchange

In turn, output data written by the fieldbus master can be used to update enunciator elements on the HMI panel. Enunciator elements might be:

- display indicators
- buttons or screen images that change color or shape
- data display screens (for example, temperature read-outs)

To use the HMI panel as an output device, you need to enable the fieldbus-to-HMI block in the island's data image (*see page 122*) and specify the number of registers in this block that you want to use. You need to use the Advantys configuration software to make these adjustments to your configuration.

The fieldbus master-to-HMI block can comprise up to 512 registers, ranging from register 44097 to 44608. This block follows immediately after the standard output data process image (*see page 133*) block (registers 40001 through 44096) in the island's data image.

The fieldbus master writes output update data in native fieldbus format to the HMI data block concurrent with writing this data to the output data process image area. The output data is placed in the fieldbus master-to-HMI block. Upon request by the HMI via a Modbus *read* command, the role of the NIM is to receive this output data, convert it to 16-bit Modbus format, and send it over the Modbus connection at the CFG port to the HMI panel.

NOTE: The *read* command enables all Modbus registers to be read, not just those in the block reserved for fieldbus master-to-HMI data exchange.

Test Mode

Summary

Test Mode indicates that the output data of the STB island's process image is not controlled by a fieldbus master device, but is instead controlled by either the Advantys Configuration Software or an HMI. When the STB island is operating in Test Mode, the fieldbus master cannot write the STB island's outputs, but can continue to read its inputs and diagnostic data.

Test Mode is configured off-line, downloaded with the island configuration, then activated online.

Select Test Mode Settings in the **Online** menu to open the Test Mode configuration window, where you can select a test mode setting. Test Mode settings are stored with other STB island configuration settings both in the NIM's flash memory and in a SIM card, if one is attached to the NIM.

When Test Mode is activated, the NIM's TEST LED is lit, and bit #5 of the NIM Status word in register 45391 is set to 1.

NOTE: Loss of Modbus communications do not affect Test Mode.

There are three Test Mode settings:

- Temporary Test Mode
- Persistent Test Mode
- Password Test Mode

The following sections describe the process and effect of activating Test Mode.

Temporary Test Mode

When operating online, use the Advantys Configuration Software (not an HMI) to activate Temporary Test Mode, by selecting **Test Mode** in the **Online** menu.

Once activated, Temporary Test Mode is deactivated by:

- de-selecting **Test Mode** in the **Online** menu
- cycling power to the NIM
- selecting **Reset** in the **Online** menu
- performing Autoconfiguration
- downloading a new island configuration to the NIM (or inserting a SIM card with a new island configuration into the NIM and cycling power to the NIM).

Temporary Test Mode is the default Test Mode configuration setting.

Persistent Test Mode

Use the Advantys Configuration Software to configure the STB island for Persistent Test Mode. When the download of this configuration is complete, Persistent Test Mode is activated. Thereafter, the STB island operates in Test Mode each time power is cycled to the island. When Persistent Test Mode is activated, the STB island's process image output data is controlled exclusively by either the HMI or the configuration software. The fieldbus master no longer controls these outputs.

Persistent Test Mode is deactivated by:

- downloading a new island configuration to the NIM (or inserting a SIM card with a new island configuration into the NIM and cycling power to the NIM)
- performing Autoconfiguration.

Password Test Mode

Use the Advantys Configuration Software to enter a password to the STB island's configuration settings. The password you input must have an integer value from 1 to 65535 (FFFF hex).

After the changed configuration (including the password) has been downloaded, you can activate Password Test Mode only by using an HMI to issue a single Modbus Register write command to send the password value to Modbus Register 45120.

After Password Test Mode is activated, the STB island's process image output data is controlled by either the HMI or the configuration software. In this case, the fieldbus master no longer controls these outputs.

Password Test Mode, once activated, is deactivated by:

- cycling power to the NIM
- selecting **Reset** in the **Online** menu
- performing Autoconfiguration
- downloading a new island configuration to the NIM (or inserting a SIM card with a new island configuration into the NIM and cycling power to the NIM)
- using an HMI to issue a single Modbus register write command to send the password value to Modbus Register 45121 (STB NIC 2212 and STB NIP 2311 NIMs only)

NOTE: Password Test Mode must be activated only by using the NIM's configuration port. All attempts to enter Password Test Mode using the fieldbus (via NIM models STB NMP 2212 or STB NIP 2212) are unsuccessful.

Run-Time Parameters

Introduction

For STB modules, the Advantys Configuration Software provides the RTP (run-time parameters) feature. It can be used for monitoring and modifying selected I/O parameters and Island bus status registers of the NIM while the Island is running. This feature is available only in standard STB NIMs with firmware version 2.0 or later.

RTP must be configured using the Advantys Configuration Software before it can be used. RTP is not configured by default. Configure RTP by selecting **Configure run-time Parameters** in the **Options** tab of the NIM Module Editor. This allocates the necessary registers within the NIM's data process image to support this feature.

Request and Response Blocks

Once configured, use the RTP feature by writing up to 5 reserved words in the NIM's output data process image (the RTP request block) and by reading the value of 4 reserved words in the NIM's input data process image (the RTP response block). The Advantys Configuration Software displays both blocks of reserved RTP words in the Island's **I/O Image Overview** dialog box, both in the **Modbus Image** tab and (for NIMs with a separate fieldbus image) in the **Fieldbus Image** tab. In each tab, the blocks of reserved RTP words appear after the block of process I/O data and before the block of HMI data (if any).

NOTE: The Modbus address values of the RTP request and response blocks are the same in all standard NIMs. The fieldbus address values of the RTP request and response blocks depend upon the network type. Use the **Fieldbus Image** tab of the **I/O Image Overview** dialog box to obtain the location of the RTP registers. For Modbus Plus and Ethernet networks, use the Modbus register numbers.

Exceptions

Any parameter you modify using the RTP feature does not retain its modified value if one of the following events occurs:

- Power is cycled to the NIM.
- A **Reset** command is issued to the NIM using the Advantys Configuration Software.
- A **Store to SIM Card** command is issued using the Advantys Configuration Software.
- The module whose parameter has been modified is hot-swapped.
If a module is hot-swapped, as indicated by the HOT_SWAP indicator bit, you can use the RTP feature to detect which module has been hot-swapped and to restore the parameters to their previous values.

Test Mode

When the NIM is operating in test mode, the NIM's output data process image (including the RTP request block) can be controlled either by the Advantys Configuration Software or by an HMI (depending upon the test mode configured). Standard Modbus commands can be used to access the RTP words. If the NIM is in test mode, the fieldbus master cannot write to the RTP request block in the NIM's output data process image.

RTP Request Block Words Definitions

The following table lists RTP request block words:

Modbus Address	Upper Byte	Lower Byte	Data Type	Attribute
45130	sub-index	toggle + length	unsigned 16	RW
45131	index (high data byte)	index (low data byte)	unsigned 16	RW
45132	data byte 2	data byte 1 (LSB)	unsigned 16	RW
45133	data byte 4 (MSB)	data byte 3	unsigned 16	RW
45134	toggle + CMD	Node ID	unsigned 16	RW
<p>NOTE: The RTP request block is also presented in the manufacturer specific area of the CANopen fieldbus as an object with a dedicated index of 0x4101 and sub-index 1 to 5 (data type = unsigned 16, attribute = RW).</p>				

The NIM performs range checking on the above bytes as follows:

- index (high / low byte): 0x2000 to 0xFFFF for write; 0x1000 to 0xFFFF for read
- toggle + length: length = 1 to 4 bytes; the most significant bit contains the toggle bit
- toggle + CMD: CMD = 1 to 0x0A (see the table *Valid Commands*, below); most significant bit contains toggle bit
- Node ID: 1 to 32 and 127 (the NIM itself)

The toggle+CMD and toggle+length bytes are at either end of the RTP request register block. The NIM processes the RTP request when the same value is set in the respective toggle bits of these two bytes. The NIM processes the same RTP block again only when both values have changed to a new identical value. We recommend that you configure new matching values for the two toggle bytes (toggle+CMD and toggle+length) only after you have constructed the RTP request between them.

⚠ WARNING

UNINTENDED EQUIPMENT OPERATION

Write all bytes in the RTP request before you set the `toggle+CMD` and `toggle+length` bytes to the same new value.

Failure to follow these instructions can result in death, serious injury, or equipment damage.

RTP Response Block Words Definitions

The following list shows RTP response block words:

Modbus Address	Upper Byte	Lower Byte	Data Type	Attribute
45303	status (the most significant bit is used to indicate whether RTP service is enabled: MSB=1 means enabled)	<code>toggle + CMD</code> <code>echo</code>	unsigned 16	RO
45304	data byte 2	data byte 1 (LSB)	unsigned 16	RO
45305	data byte 4 (MSB)	data byte 3	unsigned 16	RO
45306	-	<code>toggle + CMD</code> <code>echo</code>	unsigned 16	RO

NOTE: The RTP response block is also presented in the manufacturer specific area of the CANopen fieldbus as an object with a dedicated index of 0x4100 and sub-index 1 to 4 (data type = unsigned 16, attribute = RO).

The `toggle+CMD echo` bytes are located at the end of the register range to let you validate the consistency of the data wrapped within these bytes (in case RTP response block words are not updated in a single scan). The NIM updates the status byte and the 4 data bytes (if applicable) before updating the `toggle+CMD echo` bytes in Modbus register 45303 and 45306 to equal the value of the `toggle+CMD` byte of the corresponding RTP request. You must first check that both `toggle+CMD` bytes match the `toggle+CMD` byte in the RTP request block before making use of the data inside the RTP response block.

Valid RTP Commands

The following list shows valid commands (CMDs):

Command (CMD)	Code (Except the msb)	Valid Node IDs	Allowed State of the Addressed Node	Data Bytes
Enable RTP (Only After RTP Has Been Configured Using the Advantys Configuration Software)	0x08	127	N/A	-
Disable RTP	0x09	127	N/A	-
Reset Hot-Swap Bit	0x0A	1-32	N/A	-
Read Parameter	0x01	1-32, 127	pre-operational operational	data bytes in response, length to be given
Write Parameter	0x02	1-32	operational	data bytes in request, length to be given

The most significant bit of an RTP request block's `toggle+CMD` byte is the toggle bit. A new command is identified when the value of this bit changes and matches the value of the toggle bit in the `toggle+length` byte.

A new RTP request is processed only if the preceding RTP request has finished. Overlapping RTP requests are not allowed. A new RTP request made before the completion of a preceding request is ignored.

To determine when an RTP command has been processed and its response is complete, check the values of the `toggle+CMD` echo bytes in the RTP response block. Continue to check both `toggle+CMD` bytes in the RTP response block until they match the RTP request block's `toggle+CMD` byte. Once they match, the contents of the RTP response block is valid.

Valid RTP Status Messages

The following list shows valid status messages:

Status Byte	Code	Comment
Success	0x00 or 0x80	0x00 for successful completion of a Disable RTP command
Command not Processed due to Disabled RTP	0x01	-
Illegal CMD	0x82	-
Illegal Data Length	0x83	-
Illegal Node ID	0x84	-
Illegal Node State	0x85	Access is denied because a node is absent or not started.
Illegal Index	0x86	-
RTP Response Has More Than 4 Bytes	0x87	-
No Communication Possible on the Island Bus	0x88	-
Illegal Write to Node 127	0x89	-
SDO Aborted	0x90	If an SDO protocol error is detected, the data bytes in the response contain the SDO abort code according to DS301.
General Exception Response	0xFF	This is a status event of a type other than those specified above.

The most significant bit of the status byte in the RTP response block indicates whether RTP is enabled (1) or disabled (0).

Virtual Placeholder

Summary

The virtual placeholder feature lets you create a standard island configuration and depopulated variations of that configuration that share the same fieldbus process image, thereby letting you maintain a consistent PLC or fieldbus master program for various island configurations. The depopulated islands are physically built using only those modules that are not marked as *not present*, thus saving cost and space.

As part of an Advantys STB island custom configuration, you can set *Virtual Placeholder* status for any STB I/O or preferred third-party module whose node address is assigned by the NIM during auto-addressing.

After a module has been assigned Virtual Placeholder status, you can physically remove it from its Advantys STB island base, while retaining the island's process image. All modules that physically remain in the Advantys STB island configuration will retain their previous node addresses. This lets you physically alter the design of your island, without having to edit your PLC program.

NOTE: Advantys configuration software is required to set Virtual Placeholder status.

Setting Virtual Placeholder Status

To set Virtual Placeholder status:

Step	Action
1	Open the STB I/O or preferred third-party module's property window.
2	In the Options tab, select Not Present .
3	Click OK to save your settings. The Advantys STB configuration software marks the virtual placeholder module with a red "X" (as shown below).

For example, the following island configuration contains a NIM, a PDM, 2 digital Input modules, 2 digital output modules, a digital relay output module, an analog input module, and an analog output module:

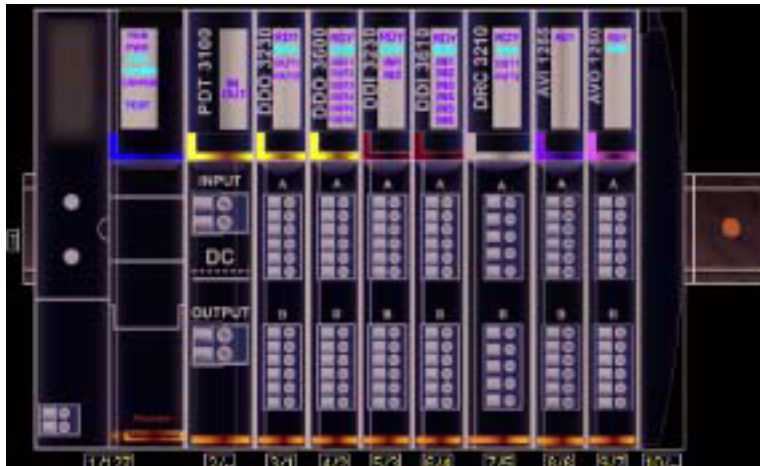

After you assign Virtual Placeholder status to the DRC 3210 digital relay output module (by selecting **Not Present** in its Options tab), the Advantys STB configuration software marks the virtual placeholder module with a red "X" as shown below:

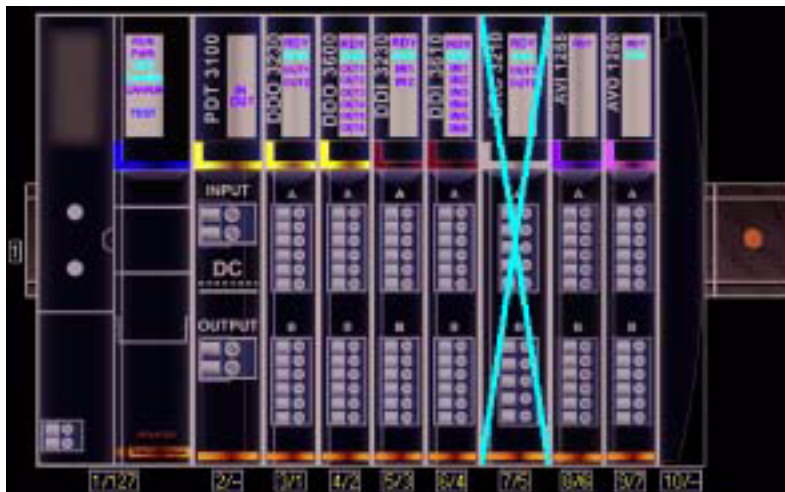

For example, when you physically construct the above configuration, you would build the island without the DRC-3210 and its base.

NOTE: Any reflex output, that is configured to use a virtual placeholder module as an input, will constantly be in fallback.

Glossary

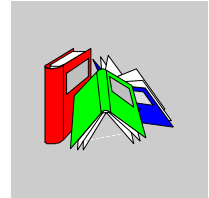

0-9

100Base-T

An adaptation of the IEEE 802.3u (Ethernet) standard, the 100Base-T standard uses twisted-pair wiring with a maximum segment length of 100 m (328 ft) and terminates with an RJ-45 connector. A 100Base-T network is a baseband network capable of transmitting data at a maximum speed of 100 Mbit/s. "Fast Ethernet" is another name for 100Base-T, because it is ten times faster than 10Base-T.

10Base-T

An adaptation of the IEEE 802.3 (Ethernet) standard, the 10Base-T standard uses twisted-pair wiring with a maximum segment length of 100 m (328 ft) and terminates with an RJ-45 connector. A 10Base-T network is a baseband network capable of transmitting data at a maximum speed of 10 Mbit/s.

802.3 frame

A frame format, specified in the IEEE 802.3 (Ethernet) standard, in which the header specifies the data packet length.

A

agent

1. SNMP – the SNMP application that runs on a network device.
2. Fipio – a slave device on a network.

analog input

A module that contains circuits that convert analog DC input signals to digital values that can be manipulated by the processor. By implication, these analog inputs are usually direct. That means a data table value directly reflects the analog signal value.

analog output

A module that contains circuits that transmit an analog DC signal proportional to a digital value input to the module from the processor. By implication, these analog outputs are usually direct. That means a data table value directly controls the analog signal value.

application object

In CAN-based networks, application objects represent device-specific functionality, such as the state of input or output data.

ARP

The ARP (address resolution protocol) is the IP network layer protocol, which uses ARP to map an IP address to a MAC (hardware) address.

auto baud

The automatic assignment and detection of a common baud rate as well as the ability of a device on a network to adapt to that rate.

auto-addressing

The assignment of an address to each Island bus I/O module and preferred device.

auto-configuration

The ability of Island modules to operate with predefined default parameters. A configuration of the Island bus based completely on the actual assembly of I/O modules.

B

basic I/O

Low-cost Advantys STB input/output modules that use a fixed set of operating parameters. A basic I/O module cannot be reconfigured with the Advantys Configuration Software and cannot be used in reflex actions.

basic network interface

A low-cost Advantys STB network interface module that supports up to 12 Advantys STB I/O modules. A basic NIM does not support the Advantys Configuration Software, reflex actions, nor the use of an HMI panel.

basic power distribution module

A low-cost Advantys STB PDM that distributes sensor power and actuator power over a single field power bus on the Island. The bus provides a maximum of 4 A total power. A basic PDM requires a 5 A fuse to protect the I/O.

BootP

BootP (bootstrap protocol) is an UDP/IP protocol that allows an internet node to obtain its IP parameters based on its MAC address.

BOS

BOS stands for beginning of segment. When more than 1 segment of I/O modules is used in an Island, an STB XBE 1200 or an STB XBE 1300 BOS module is installed in the first position in each extension segment. Its job is to carry Island bus communications to and generate logic power for the modules in the extension segment. Which BOS module must be selected depends on the module types that shall follow.

bus arbitrator

A master on a Fipio network.

C**CAN**

The CAN (controller area network) protocol (ISO 11898) for serial bus networks is designed for the interconnection of smart devices (from multiple manufacturers) in smart systems for real-time industrial applications. CAN multi-master systems ensure high data integrity through the implementation of broadcast messaging and advanced diagnostic mechanisms. Originally developed for use in automobiles, CAN is now used in a variety of industrial automation control environments.

CANopen protocol

An open industry standard protocol used on the internal communication bus. The protocol allows the connection of any enhanced CANopen device to the Island bus.

CI

This abbreviation stands for command interface.

CiA

CiA (CAN in Automation) is a non-profit group of manufacturers and users dedicated to developing and supporting CAN-based higher layer protocols.

CIP

Common Industrial Protocol. Networks that include CIP in the application layer can communicate seamlessly with other CIP-based networks. For example, the implementation of CIP in the application layer of an Ethernet TCP/IP network creates an EtherNet/IP environment. Similarly, CIP in the application layer of a CAN network creates a DeviceNet environment. Devices on an EtherNet/IP network can therefore communicate with devices on a DeviceNet network via CIP bridges or routers.

COB

A COB (communication object) is a unit of transportation (a message) in a CAN-based network. Communication objects indicate a particular functionality in a device. They are specified in the CANopen communication profile.

configuration

The arrangement and interconnection of hardware components within a system and the hardware and software selections that determine the operating characteristics of the system.

CRC

cyclic redundancy check. Messages that implement this error checking mechanism have a CRC field that is calculated by the transmitter according to the message's content. Receiving nodes recalculate the field. Disagreement in the two codes indicates a difference between the transmitted message and the one received.

CSMA/CS

carrier sense multiple access/collision detection. CSMA/CS is a MAC protocol that networks use to manage transmissions. The absence of a carrier (transmission signal) indicates that a network channel is idle. Multiple nodes may try to simultaneously transmit on the channel, which creates a collision of signals. Each node detects the collision and immediately terminates transmission. Messages from each node are retransmitted at random intervals until the frames are successfully transmitted.

D

DDXML

Device Description eXtensible Markup Language

device name

A customer-driven, unique logical personal identifier for an Ethernet NIM. A device name (or *role name*) is created when you combine the numeric rotary switch setting with the NIM (for example, STBNIP2212_010).

After the NIM is configured with a valid device name, the DHCP server uses it to identify the island at power up.

DeviceNet protocol

DeviceNet is a low-level, connection-based network that is based on CAN, a serial bus system without a defined application layer. DeviceNet, therefore, defines a layer for the industrial application of CAN.

DHCP

dynamic host configuration protocol. A TCP/IP protocol that allows a server to assign an IP address based on a device name (host name) to a network node.

differential input

A type of input design where two wires (+ and -) are run from each signal source to the data acquisition interface. The voltage between the input and the interface ground are measured by two high-impedance amplifiers, and the outputs from the two amplifiers are subtracted by a third amplifier to yield the difference between the + and - inputs. Voltage common to both wires is thereby removed. Differential design solves the problem of ground differences found in single-ended connections, and it also reduces the cross-channel noise problem.

digital I/O

An input or output that has an individual circuit connection at the module corresponding directly to a data table bit or word that stores the value of the signal at that I/O circuit. It allows the control logic to have discrete access to the I/O values.

DIN

Deutsche industrial norms. A German agency that sets engineering and dimensional standards and now has worldwide recognition.

Drivecom Profile

The Drivecom profile is part of CiA DSP 402 (profile), which defines the behavior of drives and motion control devices on CANopen networks.

E

economy segment

A special type of STB I/O segment created when an STB NCO 1113 economy CANopen NIM is used in the first location. In this implementation, the NIM acts as a simple gateway between the I/O modules in the segment and a CANopen master. Each I/O module in an economy segment acts as a independent node on the CANopen network. An economy segment cannot be extended to other STB I/O segments, preferred modules or enhanced CANopen devices.

EDS

electronic data sheet. The EDS is a standardized ASCII file that contains information about a network device's communications functionality and the contents of its object dictionary. The EDS also defines device-specific and manufacturer-specific objects.

EIA

Electronic Industries Association. An organization that establishes electrical/electronic and data communication standards.

EMC

electromagnetic compatibility. Devices that meet EMC requirements can operate within a system's expected electromagnetic limits without interruption.

EMI

electromagnetic interference. EMI can cause an interruption, malfunction, or disturbance in the performance of electronic equipment. It occurs when a source electronically transmits a signal that interferes with other equipment.

EOS

This abbreviation stands for end of segment. When more than 1 segment of I/O modules is used in an Island, an STB XBE 1000 or an STB XBE 1100 EOS module is installed in the last position in every segment that has an extension following it. The EOS module extends Island bus communications to the next segment. Which EOS module must be selected depends on the module types that shall follow.

Ethernet

A LAN cabling and signaling specification used to connect devices within a defined area, e.g., a building. Ethernet uses a bus or a star topology to connect different nodes on a network.

Ethernet II

A frame format in which the header specifies the packet type, Ethernet II is the default frame format for NIM communications.

EtherNet/IP

EtherNet/IP (the Ethernet Industrial Protocol) is especially suited to factory applications in which there is a need to control, configure, and monitor events within an industrial system. The ODVA-specified protocol runs CIP (the Common Industrial Protocol) on top of standard Internet protocols, like TCP/IP and UDP. It is an open local (communications) network that enables the interconnectivity of all levels of manufacturing operations from the plant's office to the sensors and actuators on its floor.

F**fallback state**

A known state to which an Advantys STB I/O module can return in the event that its communication connection is not open.

fallback value

The value that a device assumes during fallback. Typically, the fallback value is either configurable or the last stored value for the device.

FED_P

Fipio extended device profile. On a Fipio network, the standard device profile type for agents whose data length is more than 8 words and equal to or less than 32 words.

Fipio

Fieldbus Interface Protocol (FIP). An open fieldbus standard and protocol that conforms to the FIP/World FIP standard. Fipio is designed to provide low-level configuration, parameterization, data exchange, and diagnostic services.

Flash memory

Flash memory is nonvolatile memory that can be overwritten. It is stored on a special EEPROM that can be erased and reprogrammed.

FRD_P

Fipio reduced device profile. On a Fipio network, the standard device profile type for agents whose data length is two words or less.

FSD_P

Fipio standard device profile. On a Fipio network, the standard device profile type for agents whose data length is more than two words and equal to or less than 8 words.

full scale

The maximum level in a specific range—e.g., in an analog input circuit the maximum allowable voltage or current level is at full scale when any increase beyond that level is over-range.

function block

A function block performs a specific automation function, such as speed control. A function block comprises configuration data and a set of operating parameters.

function code

A function code is an instruction set commanding 1 or more slave devices at a specified address(es) to perform a type of action, e.g., read a set of data registers and respond with the content.

G

gateway

A program or hardware that passes data between networks.

global_ID

global_identifier. A 16-bit integer that uniquely identifies a device's location on a network. A global_ID is a symbolic address that is universally recognized by all other devices on the network.

GSD

generic slave data (file). A device description file, supplied by the device's manufacturer, that defines a device's functionality on a Profibus DP network.

H**HMI**

human-machine interface. An operator interface, usually graphical, for industrial equipment.

hot swapping

Replacing a component with a like component while the system remains operational. When the replacement component is installed, it begins to function automatically.

HTTP

hypertext transfer protocol. The protocol that a web server and a client browser use to communicate with one another.

I**I/O base**

A mounting device, designed to seat an Advantys STB I/O module, hang it on a DIN rail, and connect it to the Island bus. It provides the connection point where the module can receive either 24 VDC or 115/230 VAC from the input or output power bus distributed by a PDM.

I/O module

In a programmable controller system, an I/O module interfaces directly to the sensors and actuators of the machine/process. This module is the component that mounts in an I/O base and provides electrical connections between the controller and the field devices. Normal I/O module capacities are offered in a variety of signal levels and capacities.

I/O scanning

The continuous polling of the Advantys STB I/O modules performed by the COMS to collect data bits, status, and diagnostics information.

IEC

International Electrotechnical Commission Carrier. Founded in 1884 to focus on advancing the theory and practice of electrical, electronics, and computer engineering, and computer science. EN 61131-2 is the specification that deals with industrial automation equipment.

IEC type 1 input

Type 1 digital inputs support sensor signals from mechanical switching devices such as relay contacts and push buttons operating in normal environmental conditions.

IEC type 2 input

Type 2 digital inputs support sensor signals from solid state devices or mechanical contact switching devices such as relay contacts, push buttons (in normal or harsh environmental conditions), and 2- or 3-wire proximity switches.

IEC type 3 input

Type 3 digital inputs support sensor signals from mechanical switching devices such as relay contacts, push buttons (in normal-to-moderate environmental conditions), 3-wire proximity switches and 2-wire proximity switches that have:

- a voltage drop of no more than 8 V
- a minimum operating current capability less than or equal to 2.5 mA
- a maximum off-state current less than or equal to 1.5 mA

IEEE

Institute of Electrical and Electronics Engineers, Inc. The international standards and conformity assessment body for all fields of electrotechnology, including electricity and electronics.

industrial I/O

An Advantys STB I/O module designed at a moderate cost for typical continuous, high-duty-cycle applications. Modules of this type often feature standard IEC threshold ratings, usually providing user-configurable parameter options, on-board protection, good resolution, and field wiring options. They are designed to operate in moderate-to-high temperature ranges.

input filtering

The amount of time that a sensor must hold its signal on or off before the input module detects the change of state.

input polarity

An input channel's polarity determines when the input module sends a 1 and when it sends a 0 to the master controller. If the polarity is *normal*, an input channel sends a 1 to the controller when its field sensor turns on. If the polarity is *reverse*, an input channel sends a 0 to the controller when its field sensor turns on.

input response time

The time it takes for an input channel to receive a signal from the field sensor and put it on the Island bus.

INTERBUS protocol

The INTERBUS fieldbus protocol observes a master/slave network model with an active ring topology, having all devices integrated in a closed transmission path.

IOC object

Island operation control object. A special object that appears in the CANopen object dictionary when the remote virtual placeholder option is enabled in a CANopen NIM. It is a 16-bit word that provides the fieldbus master with a mechanism for issuing reconfiguration and start requests.

IOS object

Island operation status object. A special object that appears in the CANopen object dictionary when the remote virtual placeholder option is enabled in a CANopen NIM. It is a 16-bit word that reports the success of reconfiguration and start requests or records diagnostic information in the event that a request is not completed.

IP

internet protocol. That part of the TCP/IP protocol family that tracks the internet addresses of nodes, routes outgoing messages, and recognizes incoming messages.

IP Rating

Ingress Protection rating according to IEC 60529.

IP20 modules are protected against ingress and contact of objects larger than 12.5 mm. The module is not protected against harmful ingress of water.

IP67 modules are completely protected against ingress of dust and contact. Ingress of water in harmful quantity is not possible when the enclosure is immersed in water up to 1 m.

L

LAN

local area network. A short-distance data communications network.

light industrial I/O

An Advantys STB I/O module designed at a low cost for less rigorous (e.g., intermittent, low-duty-cycle) operating environments. Modules of this type operate in lower temperature ranges with lower qualification and agency requirements and limited on-board protection; they usually have limited or no user-configuration options.

linearity

A measure of how closely a characteristic follows a straight-line function.

LSB

least significant bit, least significant byte. The part of a number, address, or field that is written as the rightmost single value in conventional hexadecimal or binary notation.

M

MAC address

media access control address. A 48-bit number, unique on a network, that is programmed into each network card or device when it is manufactured.

mandatory module

When an Advantys STB I/O module is configured to be mandatory, it must be present and healthy in the Island configuration for the Island to be operational. If a mandatory module is inoperable or is removed from its location on the Island bus, the Island goes to a pre-operational state. By default, all I/O modules are not mandatory. You must use the Advantys Configuration Software to set this parameter.

master/slave model

The direction of control in a network that implements the master/slave model is always from the master to the slave devices.

Modbus

Modbus is an application layer messaging protocol. Modbus provides client and server communications between devices connected on different types of buses or networks. Modbus offers many services specified by function codes.

MOV

metal oxide varistor. A 2-electrode semiconductor device with a voltage-dependant nonlinear resistance that drops markedly as the applied voltage is increased. It is used to suppress transient voltage surges.

MSB

most significant bit, most significant byte. The part of a number, address, or field that is written as the leftmost single value in conventional hexadecimal or binary notation.

N**N.C. contact**

normally closed contact. A relay contact pair that is closed when the relay coil is de-energized and open when the coil is energized.

N.O. contact

normally open contact. A relay contact pair that is open when the relay coil is de-energized and closed when the coil is energized.

NEMA

National Electrical Manufacturers Association

network cycle time

The time that a master requires to complete a single scan of all of the configured I/O modules on a network device; typically expressed in microseconds.

NIM

network interface module. This module is the interface between an Island bus and the fieldbus network of which the Island is a part. A NIM enables all the I/O on the Island to be treated as a single node on the fieldbus. The NIM also provides 5 V of logic power to the Advantys STB I/O modules in the same segment as the NIM.

NMT

network management. NMT protocols provide services for network initialization, diagnostic control, and device status control.

O

object dictionary

Part of the CANopen device model that provides a map to the internal structure of CANopen devices (according to CANopen profile DS-401). A device's object dictionary (also called the *object directory*) is a lookup table that describes the data types, communications objects, and application objects the device uses. By accessing a particular device's object dictionary through the CANopen fieldbus, you can predict its network behavior and build a distributed application.

ODVA

Open Devicenet Vendors Association. The ODVA supports the family of network technologies that are built on the Common Industrial Protocol (EtherNet/IP, DeviceNet, and CompoNet).

open industrial communication network

A distributed communication network for industrial environments based on open standards (EN 50235, EN50254, and EN50170, and others) that allows the exchange of data between devices from different manufacturers.

output filtering

The amount that it takes an output channel to send change-of-state information to an actuator after the output module has received updated data from the NIM.

output polarity

An output channel's polarity determines when the output module turns its field actuator on and when it turns the actuator off. If the polarity is *normal*, an output channel turns its actuator on when the master controller sends it a 1. If the polarity is *reverse*, an output channel turns its actuator on when the master controller sends it a 0.

output response time

The time it takes for an output module to take an output signal from the Island bus and send it to its field actuator.

P

parameterize

To supply the required value for an attribute of a device at run-time.

PDM

power distribution module. A module that distributes either AC or DC field power to a cluster of I/O modules directly to its right on the Island bus. A PDM delivers field power to the input modules and the output modules. It is important that all the I/O clustered directly to the right of a PDM be in the same voltage group—either 24 VDC, 115 VAC, or 230 VAC.

PDO

process data object. In CAN-based networks, PDOs are transmitted as unconfirmed broadcast messages or sent from a producer device to a consumer device. The transmit PDO from the producer device has a specific identifier that corresponds to the receive PDO of the consumer devices.

PE

protective earth. A return line across the bus for fault currents generated at a sensor or actuator device in the control system.

peer-to-peer communications

In peer-to-peer communications, there is no master/slave or client/server relationship. Messages are exchanged between entities of comparable or equivalent levels of functionality, without having to go through a third party (like a master device).

PLC

programmable logic controller. The PLC is the brain of an industrial manufacturing process. It automates a process as opposed to relay control systems. PLCs are computers suited to survive the harsh conditions of the industrial environment.

PowerSuite Software

PowerSuite Software is a tool for configuring and monitoring control devices for electric motors, including ATV31, ATV71, and TeSys U.

preferred module

An I/O module that functions as an auto-addressable device on an Advantys STB Island but is not in the same form factor as a standard Advantys STB I/O module and therefore does not fit in an I/O base. A preferred device connects to the Island bus via an EOS module and a length of a preferred module extension cable. It can be extended to another preferred module or back into a BOS module. If it is the last device on the Island, it must be terminated with a 120 Ω terminator.

premium network interface

A premium NIM has advanced features over a standard or basic NIM.

prioritization

An optional feature on a standard NIM that allows you to selectively identify digital input modules to be scanned more frequently during a the NIM's logic scan.

process I/O

An Advantys STB I/O module designed for operation at extended temperature ranges in conformance with IEC type 2 thresholds. Modules of this type often feature high levels of on-board diagnostics, high resolution, user-configurable parameter options, and higher levels of agency approval.

process image

A part of the NIM firmware that serves as a real-time data area for the data exchange process. The process image includes an input buffer that contains current data and status information from the Island bus and an output buffer that contains the current outputs for the Island bus, from the fieldbus master.

producer/consumer model

In networks that observe the producer/consumer model, data packets are identified according to their data content rather than by their node address. All nodes *listen* on the network and consume those data packets that have appropriate identifiers.

Profibus DP

Profibus Decentralized Peripheral. An open bus system that uses an electrical network based on a shielded 2-wire line or an optical network based on a fiber-optic cable. DP transmission allows for high-speed, cyclic exchange of data between the controller CPU and the distributed I/O devices.

R

reflex action

A simple, logical command function configured locally on an Island bus I/O module. Reflex actions are executed by Island bus modules on data from various Island locations, like input and output modules or the NIM. Examples of reflex actions include compare and copy operations.

repeater

An interconnection device that extends the permissible length of a bus.

reverse polarity protection

Use of a diode in a circuit to protect against damage and unintended operation in the event that the polarity of the applied power is accidentally reversed.

rms

root mean square. The effective value of an alternating current, corresponding to the DC value that produces the same heating effect. The rms value is computed as the square root of the average of the squares of the instantaneous amplitude for 1 complete cycle. For a sine wave, the rms value is 0.707 times the peak value.

role name

A customer-driven, unique logical personal identifier for an Ethernet NIM. A role name (or *device name*) is created when you:

- combine the numeric rotary switch setting with the NIM (for example, STBNIP2212_010), or . . .
- edit the **Device Name** setting in the NIM's embedded web server pages

After the NIM is configured with a valid role name, the DHCP server uses it to identify the island at power up.

RTD

resistive temperature detect. An RTD device is a temperature transducer composed of conductive wire elements typically made of platinum, nickel, copper, or nickel-iron. An RTD device provides a variable resistance across a specified temperature range.

RTP

run-time parameters. RTP lets you monitor and modify selected I/O parameters and Island bus status registers of the NIM while the Advantys STB Island is running. The RTP feature uses 5 reserved output words in the NIM's process image (the RTP request block) to send requests, and 4 reserved input words in the NIM's process image (the RTP response block) to receive responses. Available only in standard NIMs running firmware version 2.0 or higher.

Rx

reception. For example, in a CAN-based network, a PDO is described as an RxPDO of the device that receives it.

S

SAP

service access point. The point at which the services of 1 communications layer, as defined by the ISO OSI reference model, is made available to the next layer.

SCADA

supervisory control and data acquisition. Typically accomplished in industrial settings by means of microcomputers.

SDO

service data object. In CAN-based networks, SDO messages are used by the fieldbus master to access (read/write) the object directories of network nodes.

segment

A group of interconnected I/O and power modules on an Island bus. An Island must have at least 1 segment and, depending on the type of NIM used, may have as many as 7 segments. The first (leftmost) module in a segment needs to provide logic power and Island bus communications to the I/O modules on its right. In the primary or basic segment, that function is filled by a NIM. In an extension segment, that function is filled by an STB XBE 1200 or an STB XBE 1300 BOS module.

SELV

safety extra low voltage. A secondary circuit designed and protected so that the voltage between any 2 accessible parts (or between 1 accessible part and the PE terminal for Class 1 equipment) does not exceed a specified value under normal conditions or under single-fault conditions.

SIM

subscriber identification module. Originally intended for authenticating users of mobile communications, SIMs now have multiple applications. In Advantys STB, configuration data created or modified with the Advantys Configuration Software can be stored on a SIM (referred to as the “removable memory card”) and then written to the NIM’s Flash memory.

single-ended inputs

An analog input design technique whereby a wire from each signal source is connected to the data acquisition interface, and the difference between the signal and ground is measured. For the success of this design technique, 2 conditions are imperative: the signal source must be grounded, and the signal ground and data acquisition interface ground (the PDM lead) must have the same potential.

sink load

An output that, when turned on, receives DC current from its load.

size 1 base

A mounting device, designed to seat an STB module, hang it on a DIN rail, and connect it to the Island bus. It is 13.9 mm (0.55 in.) wide and 128.25 mm (5.05 in.) high.

size 2 base

A mounting device, designed to seat an STB module, hang it on a DIN rail, and connect it to the Island bus. It is 18.4 mm (0.73 in.) wide and 128.25 mm (5.05 in.) high.

size 3 base

A mounting device, designed to seat an STB module, hang it on a DIN rail, and connect it to the Island bus. It is 28.1 mm (1.11 in.) wide and 128.25 mm (5.05 in.) high.

slice I/O

An I/O module design that combines a small number of channels (usually between 2 and 6) in a small package. The idea is to allow a system developer to purchase just the right amount of I/O and to be able to distribute it around the machine in an efficient, mechatronics way.

SM_MPS

state management_message periodic services. The applications and network management services used for process control, data exchange, diagnostic message reporting, and device status notification on a Fipio network.

SNMP

simple network management protocol. The UDP/IP standard protocol used to manage nodes on an IP network.

snooper

A circuit generally used to suppress inductive loads—it consists of a resistor in series with a capacitor (in the case of an RC snubber) and/or a metal-oxide varistor placed across the AC load.

source load

A load with a current directed into its input; must be driven by a current source.

standard I/O

Any of a subset of Advantys STB input/output modules designed at a moderate cost to operate with user-configurable parameters. A standard I/O module may be reconfigured with the Advantys Configuration Software and, in most cases, may be used in reflex actions.

standard network interface

An Advantys STB network interface module designed at moderate cost to support the configuration capabilities, multi-segment design and throughput capacity suitable for most standard applications on the Island bus. An Island run by a standard NIM can support up to 32 addressable Advantys STB and/or preferred I/O modules, up to 12 of which may be standard CANopen devices.

standard power distribution module

An Advantys STB module that distributes sensor power to the input modules and actuator power to the output modules over two separate power buses on the Island. The bus provides a maximum of 4 A to the input modules and 8 A to the output modules. A standard PDM requires a 5 A fuse to protect the input modules and an 8 A fuse to protect the outputs.

STD_P

standard profile. On a Fipio network, a standard profile is a fixed set of configuration and operating parameters for an agent device, based on the number of modules that the device contains and the device's total data length. There are 3 types of standard profiles: Fipio reduced device profile (FRD_P), Fipio standard device profile (FSD_P), and the Fipio extended device profile (FED_P).

stepper motor

A specialized DC motor that allows discrete positioning without feedback.

subnet

A part of a network that shares a network address with the other parts of a network. A subnet may be physically and/or logically independent of the rest of the network. A part of an internet address called a subnet number, which is ignored in IP routing, distinguishes the subnet.

surge suppression

The process of absorbing and clipping voltage transients on an incoming AC line or control circuit. Metal-oxide varistors and specially designed RC networks are frequently used as surge suppression mechanisms.

T**TC**

thermocouple. A TC device is a bimetallic temperature transducer that provides a temperature value by measuring the voltage differential caused by joining together two different metals at different temperatures.

TCP

transmission control protocol. A connection-oriented transport layer protocol that provides reliable full-duplex data transmission. TCP is part of the TCP/IP suite of protocols.

telegram

A data packet used in serial communication.

TFE

transparent factory Ethernet. Schneider Electric's open automation framework based on TCP/IP.

Tx

transmission. For example, in a CAN-based network, a PDO is described as a TxPDO of the device that transmits it.

U

UDP

user datagram protocol. A connectionless mode protocol in which messages are delivered in a datagram to a destination computer. The UDP protocol is typically bundled with the Internet Protocol (UPD/IP).

V

varistor

A 2-electrode semiconductor device with a voltage-dependant nonlinear resistance that drops markedly as the applied voltage is increased. It is used to suppress transient voltage surges.

voltage group

A grouping of Advantys STB I/O modules, all with the same voltage requirement, installed directly to the right of the appropriate power distribution module (PDM) and separated from modules with different voltage requirements. Never mix modules with different voltage requirements in the same voltage group.

VPCR object

virtual placeholder configuration read object. A special object that appears in the CANopen object dictionary when the remote virtual placeholder option is enabled in a CANopen NIM. It provides a 32-bit subindex that represents the actual module configuration used in a physical Island.

VPCW object

virtual placeholder configuration write object. A special object that appears in the CANopen object dictionary when the remote virtual placeholder option is enabled in a CANopen NIM. It provides a 32-bit subindex where the fieldbus master can write a module reconfiguration. After the fieldbus writes to the VPCW subindex, it can issue a reconfiguration request to the NIM that begins the remote virtual placeholder operation.

W**watchdog timer**

A timer that monitors a cyclical process and is cleared at the conclusion of each cycle. If the watchdog runs past its programmed time period, it generates a fault.

Index

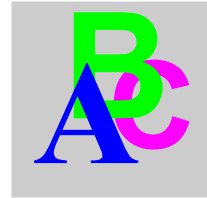

A

ABL8 Phaseo power supply, 47
action module, 115
addressable module, 16, 52, 52, 83, 135
Advantys configuration software, 38, 106, 110, 112, 114, 115, 119, 120, 123, 123, 134
agent
 defined, 20
 STB NFP 2212, 21, 22
application_process_control, 76, 76, 77, 81
application_status_control, 77, 81
auto-addressing, 16, 52, 63
auto-configuration
 and reset, 54, 62, 63
 defined, 54
 initial configuration, 54

B

baud
 CFG port, 38, 62
 fieldbus interface, 62
bus arbitrator
 defined, 20
 TSX Premium, 21

C

CFG port
 devices connecting to, 12, 38, 39
 parameters, 38, 63
 physical description, 38

class 1 device
 configuring, 76
 defined, 20
 operating parameters, 68
configurable parameters, 106, 106
configuration data
 FED_P requirements, 73
 FSD_P requirements, 71
 restoring default settings, 38, 58, 63
 saving, 58, 63
 selecting an STD_P, 20, 67, 67, 70, 71, 73, 76
configuration data
 FRD_P requirements, 70
custom configuration, 54, 55, 58, 62, 110, 119, 120

D

data exchange, 12, 33, 35, 52, 76, 81, 83, 84, 143, 144
data image, 81, 122, 133, 137, 138, 143
data size, 107, 108
device_promptness_value, 68
diagnostics block
 in the process image, 124
 island communications, 124

E

edit mode, 38, 55, 58, 58, 59, 62
explicit data, 85

extension cable, *16, 44*
extension module, *13, 15, 43, 44, 45, 46, 52*
extension segment, *13, 15, 43, 44, 45, 46*

F

factory default settings, *38, 54, 58, 63*
fallback state, *110, 117*
fallback value, *76, 110, 118*
fieldbus master

- and the output data image, *134, 136*
- calculating network cycle times, *74*
- commands used, *76*
- communicating the island's status to, *131*
- fieldbus-to-HMI block, *144*
- HMI-to-fieldbus block, *143*
- operational mode, *77*
- troubleshooting, *85, 85, 88*
- TSX P 57453 configuration example, *96*

Fipio

- applications variables, *77, 78*
- bit-packing, *81, 82, 84, 84*
- fieldbus interface, *29*
- global identifiers, *21*
- input data image, *84*
- network communications, *19, 21, 22, 33, 78*
- network management services, *22, 77, 78*
- output data image, *84*
- overview, *19*
- process control, *20, 22, 75, 75, 77, 81*
- topologies used, *21*
- troubleshooting, *131*

Fipio application example, *93*
Fipio extended device profile (FED_P)

- example, *73*
- specific channel diagnostic data, *31, 87*
- standard channel diagnostic data, *85*

Fipio fieldbus master

- and the output data image, *81*

Fipio network, *26, 28, 30, 68*
Fipio protocol, *19, 19*

Fipio reduced device profile (FRD_P)

- example, *70*
- standard diagnostic data, *85*

Fipio specific channel diagnostic data

- island bus communications, *89*
- overview, *87*
- PL7 address assignments, *87*

Fipio standard, *19, 20, 29, 29, 48, 68*
Fipio standard channel diagnostic data

- bit assignments, *85*
- overview, *85*
- PL7 address assignments, *85*
- validity of inputs, *86*

Fipio standard device profile (FSD_P)

- example, *71*
- standard channel diagnostic data, *85*

Fipio transmission

- specifications, *29*

Flash memory

- Advantys configuration software, *119*
- and reset, *61, 63*
- overwriting, *58, 63, 120*
- saving configuration data, *54*

function block (FB)

- and STD_Ps, *68*
- global identifiers, *68*
- operating parameters, *68, 68, 77*
- reporting the operating state of the STB NFP 2212, *76*

G

global bits errors, *90, 125*
global identifier

- device node address, *19*
- operating parameters, *68*

H

HE-13 connector, *39*
heartbeat message, *117*
HMI panel

- data exchange, *12, 106, 107, 123, 123,*

143, 144
functionality, 143
process image blocks, 143
hot-swapping
 mandatory modules, 111
hot-swapping modules, 53, 110

I

initial configuration, 58, 59
inputs
 to a reflex block, 114
island bus
 communications, 12
 configuration data, 20, 55, 58, 63, 67, 67,
 70, 71, 73, 76, 120
 extending, 15, 16, 44
 fallback, 117
 heartbeat, 76
 LEDs, 35
 mastery of, 35, 85
 maximum length, 18
 operational mode, 35, 58, 62
 overview, 13, 15
 status, 124
 termination, 13, 16, 135
 troubleshooting, 85, 86
island bus
 configuration data, 135
island bus example, 52, 83, 96, 135
island bus node address
 address range, 30
 setting, 31, 98
 valid and invalid addresses, 31
island bus password, 59, 120
ISO OSI Reference Model, 19

L

LEDs
 and COMS states, 35
 and reset, 35
 FIP COM LED, 33
 FIP ERR LED, 33, 76
 FIP RUN LED, 33
 Fipio communications' status, 31, 33
 island bus, 35
 overview, 33
 PWR LED, 35
 TEST LED, 35
logic power
 considerations, 13, 16, 43, 43, 44, 45
 integrated power supply, 12, 13, 43, 45,
 45
 signal, 43
 source power supply, 13, 45

M

mandatory I/O modules, 110, 110
mandatory module hot swapping, 111
Modbus protocol, 38, 40, 121, 133, 137, 143

N

nested reflex actions, 115
network considerations, 12, 21, 28, 30, 60,
74, 78
network cycle time, 74
number of reflex blocks on an island, 116

O

operating parameters, 68, 68, 68, 68
operating states, 68, 76
outputs
 from a reflex block, 115

P

parameterization, 54
PDM, 43, 47, 52, 53, 83, 135

PL7 PRO, *31, 96, 98, 102*
PLC, *107*
preferred module, *16*
primary segment, *13, 15, 43, 45*
prioritization, *112*
process image
 analog input and output module data, *81, 134, 138*
 and reflex actions, *138*
 diagnostic blocks, *124*
 digital input and output module data, *81, 134, 138*
 echo output data, *138*
 fieldbus-to-HMI block, *144*
 graphical representation, *122*
 HMI blocks, *143*
 HMI-to-fieldbus block, *143*
 I/O status image, *81, 121, 134, 138, 143*
 input data image, *84, 134, 138, 143*
 output data image, *84, 133, 136, 144*
 overview, *121*
producer-consumer communications model, *21, 78*
protected mode, *39, 55, 58, 59, 59, 62, 120*

R

reflex action
 and fallback, *117*
 and the echo output data image area, *81, 134, 138*
 overview, *113*
reflex block types, *113*
removable memory card, *38, 55, 57, 58, 119*
rotary switches, *30*
RST button
 and auto-configuration, *63*
 and Flash memory, *61, 63*
 caution, *61, 62*
 disabled, *39, 120*
 functionality, *54, 61, 62, 62*
 LED indications, *35*
 physical description, *61*
run-time parameters, *147*

S

SM_MPS variables, *19, 77, 78*
source power supply
 considerations, *45*
 logic power, *13, 45*
 recommendations, *47*
 SELV-rated, *41, 43, 45, 45*
 two-receptacle wiring connector, *41*
specifications
 CFG port, *38*
 Fipio, *23*
 Fipio physical layer, *19*
 Fipio transmission, *29*
 STB NFP 2212, *48*
 STB XCA 4002 programming cable, *40*
standard I/O modules, *110*
standard profile
 selecting, *108*
standard profile (STD_P)
 and FB type, *68*
 FED_P, *73*
 FRD_P, *70*
 FSD_P, *71*
 selecting, *20, 67, 67, 70, 71, 73*
 simplified digital communications, *20*
 types, *67*
STB NFP 2212
 fieldbus interface, *28, 29, 29*
 Fipio agent, *21, 22*
 housing, *27*
 LEDs, *31, 33*
 limitations, *48*
 operating parameters, *68, 68, 68, 78*
 operating states, *68, 77*
 physical features, *26*
 specifications, *48*
 starting, *75*
 status, *88, 89*
 troubleshooting, *85, 87, 88, 89, 89, 90, 91, 91*
STB XCA 4002 programming cable, *39*
STB XMP 4440 removable memory card
 and reset, *38, 59*
 installing, *56*
 removing, *57*

STB XMP 4440 removable memory card
storing configuration data, 38

STB XMP 4440 removable memory card
storing configuration data, 58

STB XTS 1120 screw type power connector,
42

STB XTS 2120 spring clamp field wiring con-
nector, 42

storing configuration data
and reset, 63
in Flash memory, 54, 110, 119
to a removable memory card, 38, 55, 58,
110, 119

T

termination plate, 13, 53, 83, 135

test mode, 35

troubleshooting

- emergency messages, 128
- Fipio, 85, 85, 85, 87, 87, 88, 90, 91, 91,
131
- Fipio specific channel diagnostic data, 31
- Fipio standard channel diagnostic data,
85
- global bits errors, 90, 125
- island bus, 85, 85, 86, 124, 126, 127, 129
- specific channel diagnostic data, 87
- standard channel status diagnostic, 85
- STB NFP 2212, 85, 87, 88, 89, 89, 90,
91, 91
- using the Advantys STB LEDs, 35
- using the FIP ERR LED, 76
- using the Fipio communications LEDs,
31, 33
- validity of inputs, 86
- with the Advantys configuration software,
124
- with the HMI panel, 124

TSX P 57453 Premium application, 93, 96

V

virtual placeholder, 152

