

Harmony Pocket Remote

Wireless Remote Control System

User Guide

(Original Document)

07/2019

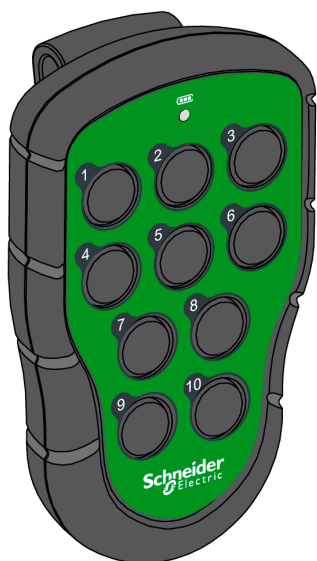

The information provided in this documentation contains general descriptions and/or technical characteristics of the performance of the products contained herein. This documentation is not intended as a substitute for and is not to be used for determining suitability or reliability of these products for specific user applications. It is the duty of any such user or integrator to perform the appropriate and complete risk analysis, evaluation and testing of the products with respect to the relevant specific application or use thereof. Neither Schneider Electric nor any of its affiliates or subsidiaries shall be responsible or liable for misuse of the information contained herein. If you have any suggestions for improvements or amendments or have found errors in this publication, please notify us.

You agree not to reproduce, other than for your own personal, noncommercial use, all or part of this document on any medium whatsoever without permission of Schneider Electric, given in writing. You also agree not to establish any hypertext links to this document or its content. Schneider Electric does not grant any right or license for the personal and noncommercial use of the document or its content, except for a non-exclusive license to consult it on an "as is" basis, at your own risk. All other rights are reserved.

All pertinent state, regional, and local safety regulations must be observed when installing and using this product. For reasons of safety and to help ensure compliance with documented system data, only the manufacturer should perform repairs to components.

When devices are used for applications with technical safety requirements, the relevant instructions must be followed.

Failure to use Schneider Electric software or approved software with our hardware products may result in injury, harm, or improper operating results.

Failure to observe this information can result in injury or equipment damage.

© 2019 Schneider Electric. All rights reserved.

Table of Contents



	Safety Information	5
	About the Book	7
Chapter 1	Description and Part Identification	9
	Wireless Remote Control System Overview	10
	Receiver Parts Identification	11
	Transmitter Parts Identification	13
	Accessories	15
Chapter 2	Specifications	17
2.1	Specifications	18
	Receiver Specifications	19
	Transmitter Specifications	20
2.2	Dimensions	21
	Receiver Dimensions	22
	Transmitter Dimensions	23
Chapter 3	Installation and Wiring	25
3.1	Receiver Installation	26
	Receiver Installation Precaution	27
	Receiver Wiring	29
	Wiring Best Practices	33
3.2	Transmitter Front Cover Customization	35
	Transmitter Front Cover Customization Creation	36
	Transmitter Front Cover Customization Installation	36
Chapter 4	Using The Wireless Remote Control System	37
4.1	Overview	38
	Register and Radio Communication	39
	Main Application	40
	Button/Relay Assignment	43
4.2	Functional Description	44
	Register the Transmitter in the Receiver	45
	Power-on the Transmitter	45
	Power-off the Transmitter	45
	Erase All Transmitters from the Receiver	45
4.3	Configuration	47
	Momentary or Latching Relay Functions	47
4.4	Transmitter Battery Replacement	48
	Transmitter Battery	48
Chapter 5	Certifications and Standards	49
	Certifications and Standards	49
Chapter 6	Diagnostic	51
	Diagnostic	51
Chapter 7	Maintenance	53
	Maintenance	53
Glossary	55



Important Information

NOTICE

Read these instructions carefully, and look at the equipment to become familiar with the device before trying to install, operate, service, or maintain it. The following special messages may appear throughout this documentation or on the equipment to warn of potential hazards or to call attention to information that clarifies or simplifies a procedure.



The addition of this symbol to a “Danger” or “Warning” safety label indicates that an electrical hazard exists which will result in personal injury if the instructions are not followed.



This is the safety alert symbol. It is used to alert you to potential personal injury hazards. Obey all safety messages that follow this symbol to avoid possible injury or death.

DANGER

DANGER indicates a hazardous situation which, if not avoided, **will result in** death or serious injury.

WARNING

WARNING indicates a hazardous situation which, if not avoided, **could result in** death or serious injury.

CAUTION

CAUTION indicates a hazardous situation which, if not avoided, **could result in** minor or moderate injury.

NOTICE

NOTICE is used to address practices not related to physical injury.

PLEASE NOTE

Electrical equipment should be installed, operated, serviced, and maintained only by qualified personnel. No responsibility is assumed by Schneider Electric for any consequences arising out of the use of this material.

A qualified person is one who has skills and knowledge related to the construction and operation of electrical equipment and its installation, and has received safety training to recognize and avoid the hazards involved.

About the Book



At a Glance

Document Scope

This manual describes how to use the Wireless Remote Control System.

Validity Note

The technical characteristics of the devices described in the present document also appear online. To access the information online:

Step	Action
1	Go to the Schneider Electric home page www.schneider-electric.com .
2	In the Search box type the reference of a product or the name of a product range. <ul style="list-style-type: none">• Do not include blank spaces in the reference or product range.• To get information on grouping similar modules, use asterisks (*).
3	If you entered a reference, go to the Product Datasheets search results and click on the reference that interests you. If you entered the name of a product range, go to the Product Ranges search results and click on the product range that interests you.
4	If more than one reference appears in the Products search results, click on the reference that interests you.
5	Depending on the size of your screen, you may need to scroll down to see the datasheet.
6	To save or print a datasheet as a .pdf file, click Download XXX product datasheet .

The characteristics that are presented in the present document should be the same as those characteristics that appear online. In line with our policy of constant improvement, we may revise content over time to improve clarity and accuracy. If you see a difference between the document and online information, use the online information as your reference.

Related Documents

Title of Documentation	Reference Number
Instruction sheet of Harmony Pocket Remote	MFR72440
Instruction sheet of pushbutton front cover for ZART03/04/06/08/10	MFR93813
Instruction sheet of pushbutton label kit and configurable front cover	MFR94227

You can download these technical publications and other technical information from our website at <https://www.schneider-electric.com/en/download>

Product Related Information

DANGER

HAZARD OF ELECTRIC SHOCK, EXPLOSION OR ARC FLASH

- Disconnect all power from all equipment including connected devices prior to removing any covers or doors, or installing or removing any accessories, hardware, cables, connectors or wires except under the specific conditions specified in this user guide.
- Always use a properly rated voltage sensing device to confirm that the power is off.
- Unplug the power cable from both the equipment and the power supply.
- Replace and secure all covers, accessories, hardware, cables, and wires and confirm that a proper ground connection exists before applying power to the equipment.
- Use only the specified voltage when operating this equipment and any associated products.
- Do not touch electrical components to avoid electrostatic discharge.

Failure to follow these instructions will result in death or serious injury.

WARNING

UNINTENDED EQUIPMENT OPERATION

- Do not replace internal parts of the receiver.
- After a receiver power off, wait around 20 seconds before removing the cover of the receiver.
- Always comply with the local requirements regarding installation and use of the devices or other systems.

Failure to follow these instructions can result in death, serious injury, or equipment damage.

Battery Warning Notes

Carefully read all instructions in this user guide, and look at the equipment to become familiar with the device before trying to install, operate, or maintain it.

For more information, contact us at www.schneider-electric.com or contact your local reseller.

WARNING

EXPLOSION, FIRE, OR CHEMICAL HAZARD

- Electric devices that have reached the end of their life must be collected separately and returned to an environmentally compatible recycling facility in accordance with national law.
- In case of electrolyte leak from battery, use adapted safety equipment and put the device in a sealed package.
- If you come into contact with electrolyte, immediately thoroughly wash the involved parts with clear water and call medical assistance.
- Do not incinerate the device.
- Do not drop or hit the device.
- Do not use a damaged device.

Failure to follow these instructions can result in death, serious injury, or equipment damage.

Chapter 1

Description and Part Identification

What Is in This Chapter?

This chapter contains the following topics:

Topic	Page
Wireless Remote Control System Overview	10
Receiver Parts Identification	11
Transmitter Parts Identification	13
Accessories	15

Wireless Remote Control System Overview

Overview

The Harmony™ Pocket Remote range of wireless remote control systems is an operator control station suitable for general machinery.

The Wireless Remote Control System is based on 2 types of devices:

- Transmitter, which is the operator command device to interface with the machine.
- Receiver, which is hardwired to the machine. It receives control commands from the Transmitter.

Receiver:

References	ZARB05WSP	ZARB11WSP
Connection	Pre-wired with 1.5 m (59 in) of cable	
Number of relays	5	11

Transmitter:

Features	ZART03	ZART04	ZART06	ZART08	ZART10
Number of single step buttons	3	4	6	8	10
User interface	1 battery LED				

The Wireless Remote Control System is a combination of these devices which communicate by radio transmission.

Main Application

Main applications modes are available:

- Single mode = one transmitter commands one receiver.
- Multi transmitter mode = several transmitters alternately commands one receiver.

For more information, refer to Main application description ([see page 40](#)).

Receiver Parts Identification

Receiver External Parts Identification

ZARB05WSP/ZARB11WSP:

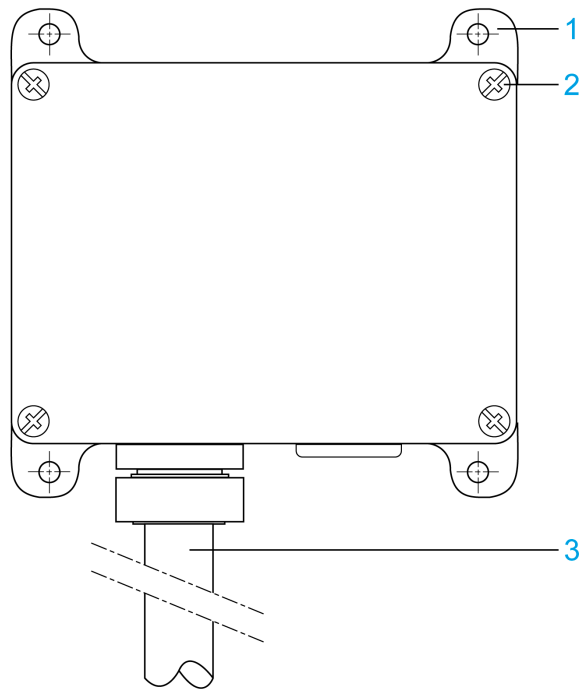

Part	Description
1	4 x Ø5 (0.20 in) holes for standard mounting on support
2	4 x screws to maintain the cover of the Receiver
3	1 x cable gland with pre-wired 1.5 m (59 in) 16-wires cable

Receiver Internal Board Parts Identification

The Receiver has an internal board:

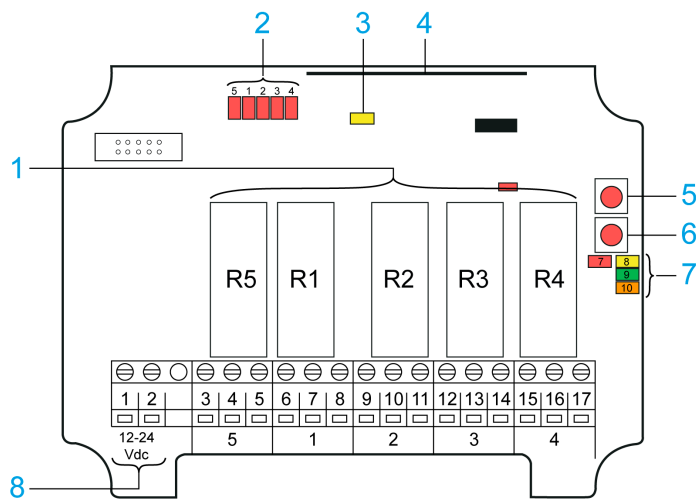

Part	Description
1	Relays R1...R5
2	Relay LEDs (red)
3	Power LED (yellow)
4	Radio module
5	Function button (cancel)
6	Select button (OK)
7	Function LEDs (7 = red, 8 = yellow, 9 = green, 10 = orange)
8	Terminal block for input power

For more information, refer to ZARB05WSP/ZARB11WSP diagnostic ([see page 51](#)).

Receiver Expansion Board Parts Identification

The ZARB11WSP Receiver has an expansion board:

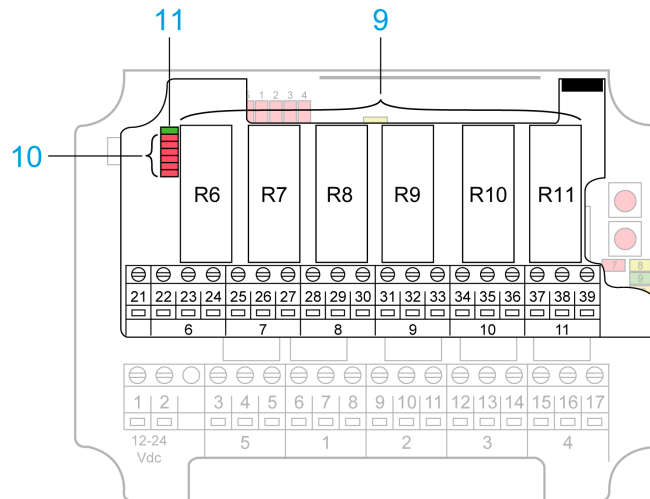

Part	Description
9	Relays R6...R11
10	Relay LEDs (red)
11	Communication LED (green)

For more information, refer to ZARB05WSP/ZARB11WSP diagnostic ([see page 51](#)).

Transmitter Parts Identification

Transmitter Front View Parts Identification

ZART03

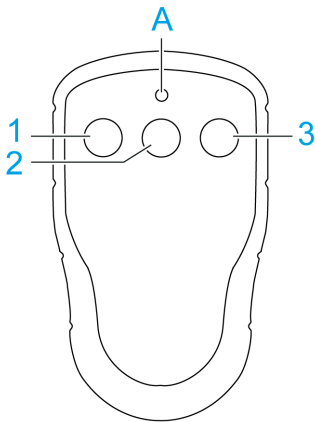

ZART04

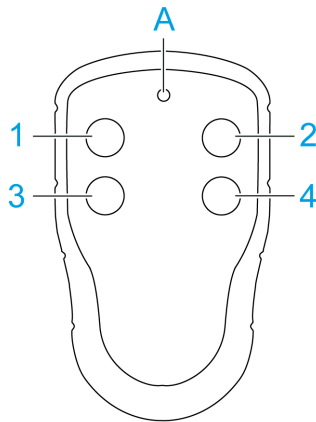

ZART06

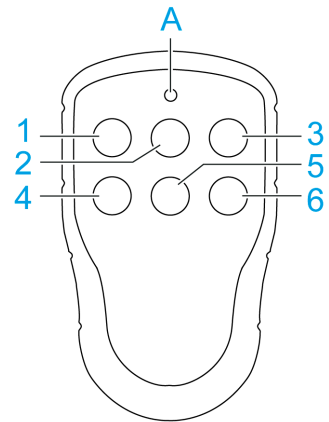

ZART08

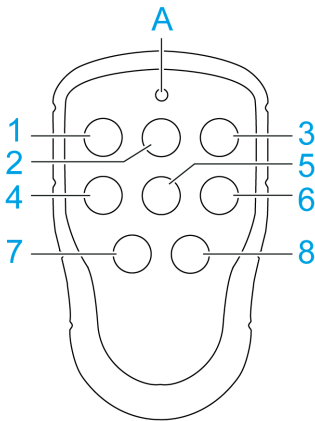

ZART10

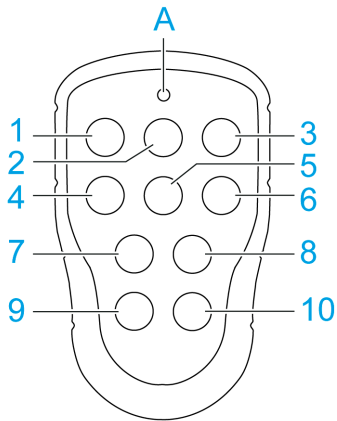

Part	Description	Part	Description
A	Battery LED (red, green)	6	Button 6
1	Button 1	7	Button 7
2	Button 2	8	Button 8
3	Button 3	9	Button 9
4	Button 4	10	Button 10
5	Button 5	-	-

Transmitter Rear View Parts Identification

ZART••:

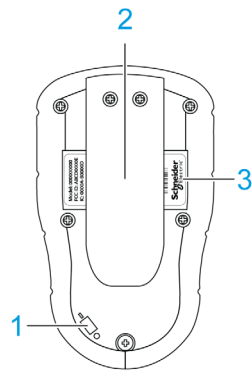

Side view:

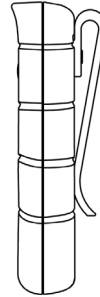



Part	Description
1	Power switch
2	Clip
3	Product label

The power switch on the back of the transmitter interrupts the power supply from the battery.

Accessories

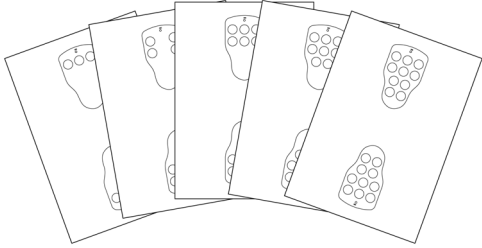
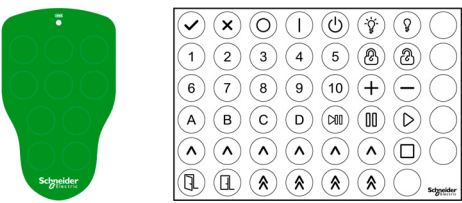
Transmitter Accessories

Device	Reference	Description
	ZARC603	Do-It-Yourself label kit for ZART03
	ZARC604	Do-It-Yourself label kit for ZART04
	ZARC606	Do-It-Yourself label kit for ZART06
	ZARC608	Do-It-Yourself label kit for ZART08
	ZARC610	Do-It-Yourself label kit for ZART10
	ZARC620	Accessories pushbutton label kit ⁽¹⁾⁽²⁾
	ZARC600 G	Configurable front cover ⁽¹⁾
<p>1 Compatible with ZART03 / ZART04 / ZART06 / ZART08 / ZART10</p> <p>2 1 base layer and individual legends</p>		

For more details about the accessories, refer to the Transmitter Front Cover Customization ([see page 35](#)).

Chapter 2

Specifications

What Is in This Chapter?

This chapter contains the following sections:

Section	Topic	Page
2.1	Specifications	18
2.2	Dimensions	21

Section 2.1

Specifications

What Is in This Section?

This section contains the following topics:

Topic	Page
Receiver Specifications	19
Transmitter Specifications	20

Receiver Specifications

Environment

The receiver specifications are described in the table:

Specifications	ZARB05WSP	ZARB11WSP
	Value	
Number of relays	5	11
Input power	12...24 Vdc	
Radio communication	Simplex	
Maximum number of registered transmitters	8	
Dimensions	120 x 117 x 51 mm (4.7 x 4.6 x 2 in)	
Weight	400 g (0.8 lbs)	
Operating temperature	-20...55 °C (-4...130 °F)	
Radio frequency	2425 MHz	
Antenna	Internal antenna	
Degree of protection	IP66	

Relays

The relays specifications are described in the table:

Specifications (Resistive load)	Value	
	AC	DC
Contact resistance	100 mΩ maximum (at 1 A and 6 Vdc)	
Contact rating, resistive load	10 A 250 Vac	10 A 30 Vdc
Maximum switching voltage	400 Vac	125 Vdc
Maximum switching current	10 A	10 A
Maximum switching power	2500 VA	300 W
Mechanical endurance	1 x 10 ⁷ cycles	
Electrical endurance	1 x 10 ⁵ cycles	

Current Consumption

Input power	Minimum ⁽¹⁾	Maximum ⁽²⁾
12 Vdc	20 mA	30 mA
24 Vdc	20 mA	20 mA

(1) Minimum current consumption = Receiver powered, no active relays, no radio session established.
(2) Maximum current consumption = Receiver powered, all relays on the receiver active, radio session established.

Relays Response Time

Maximum response time
500 ms

Transmitter Specifications

Environment

Specification	ZART03	ZART04	ZART06	ZART08	ZART10
Number of single step buttons	3	4	6	8	10
Battery	2 x 1.5 V AAA / LR03 Alkaline ⁽¹⁾				
Radio communication	Simplex				
Power switch	Yes				
Dimensions	66 x 114 x 37.5 mm / 2.6 x 4.5 x 1.5 in				
Weight (with batteries)	135 g / 0.29 lbs				
Radio Frequency	2425 MHz				
Operating time	More than 100 h with alkaline batteries (depending on the use). Replace batteries when LED turns red.				
Degree of protection	IP67				
Operating temperature	-20...55 °C (-4...130 °F)				
1 Alkaline batteries are provided with the transmitter.					

Section 2.2

Dimensions

What Is in This Section?

This section contains the following topics:

Topic	Page
Receiver Dimensions	22
Transmitter Dimensions	23

Receiver Dimensions

Dimensions

The following figure shows the receiver dimensions:

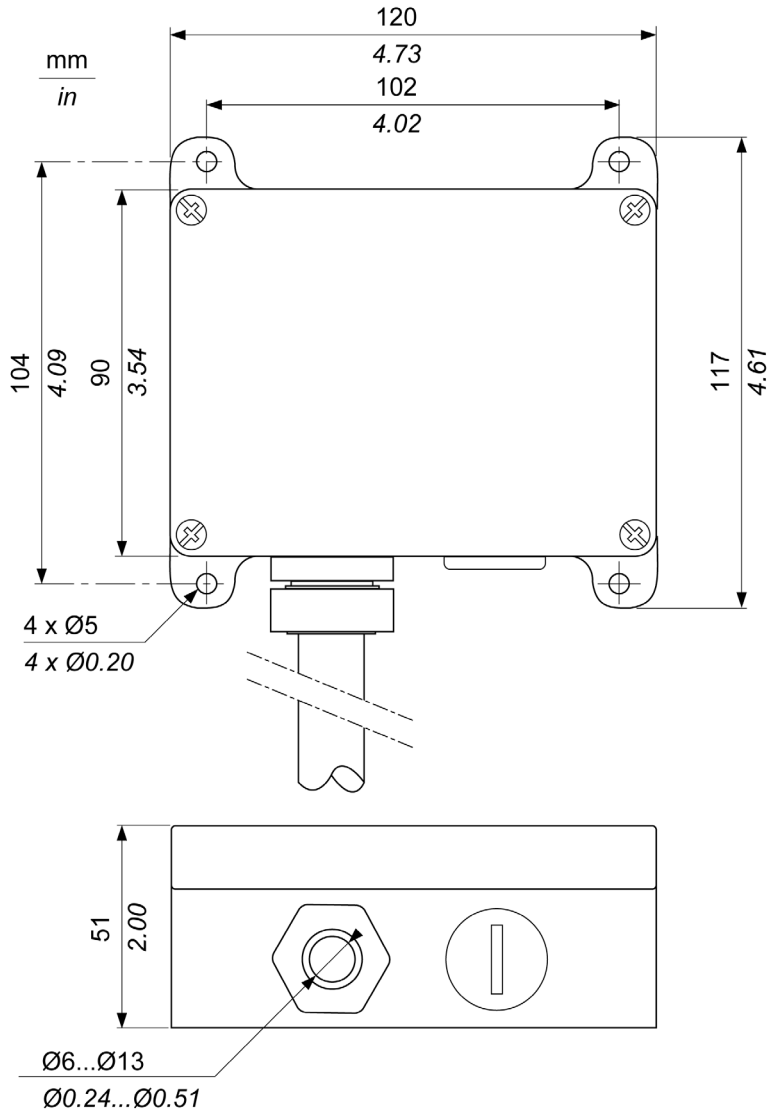

Transmitter Dimensions

Dimensions

The following figure shows the transmitter dimensions:

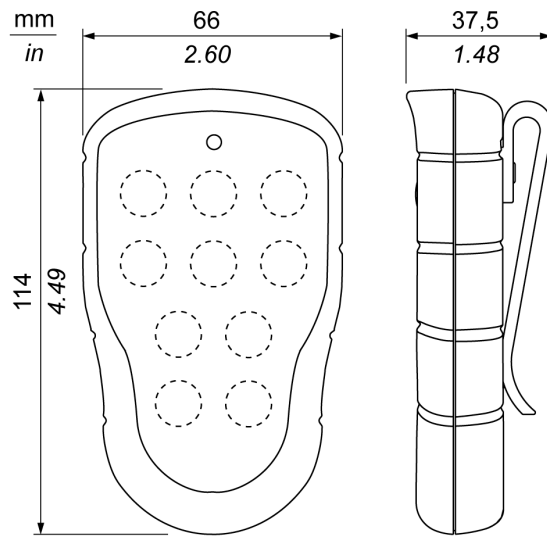

Chapter 3

Installation and Wiring

What Is in This Chapter?

This chapter contains the following sections:

Section	Topic	Page
3.1	Receiver Installation	26
3.2	Transmitter Front Cover Customization	35

Section 3.1

Receiver Installation

What Is in This Section?

This section contains the following topics:

Topic	Page
Receiver Installation Precaution	27
Receiver Wiring	29
Wiring Best Practices	33

Receiver Installation Precaution

Installation Precaution

Receiver location:

The receiver must be installed vertically, on a flat and rigid surface, with the cable at the bottom.

Consider the wiring limitation and the radio communication limitation to choose the receiver location.

Do not create obstacle between the receiver and the transmitter to optimize the radio communication level.

The receiver must not be installed inside closed metal containers.

To prevent communication perturbation:

- Do not place cables or metallic parts in front of the receiver cover.
- Do not place obstacles between the receiver and the transmitter.
- It is recommended to identify the devices with radio communication in the environment and to use only certified products.

According to IEC 61010-1, it is recommended to install the power switch of the receiver close to the receiver.

WARNING

UNINTENDED EQUIPMENT OPERATION

Install and operate this equipment according to the environmental conditions described in the operating limits.

Failure to follow these instructions can result in death, serious injury, or equipment damage.

WARNING

UNINTENDED EQUIPMENT OPERATION

- Use appropriate safety interlocks where personnel and/or equipment hazards exist.
- Use the actuator power supplies only for supplying power to the actuators connected to the device.
- Power line must be wired and protected with fuse or thermal magnetic switch (ex: Schneider-Electric GV2) in compliance with local and national regulatory requirements for the rated current and voltage of the particular equipment.
- Test the functions at each commissioning.
- Do not disassemble, repair, or modify this equipment.
- Do not drill hole in the receiver.

Failure to follow these instructions can result in death, serious injury, or equipment damage.

Installation

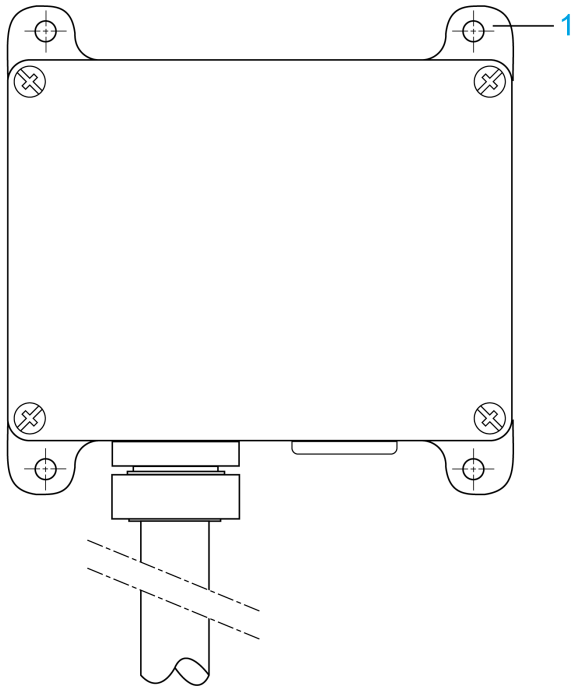
Step	Action
1	<p data-bbox="459 286 1082 318">Introduce 4 mounting screws in the Ø5 (0.20 in) holes (legend 1):</p> 
2	<p data-bbox="459 1079 1327 1124">Screw the 4 mounting M4 screws. Engage at least 6 mm (0.23 in) of the thread in mounting plate.</p>

Receiver Wiring

ZARB••WSP

ZARB••WSP terminals:

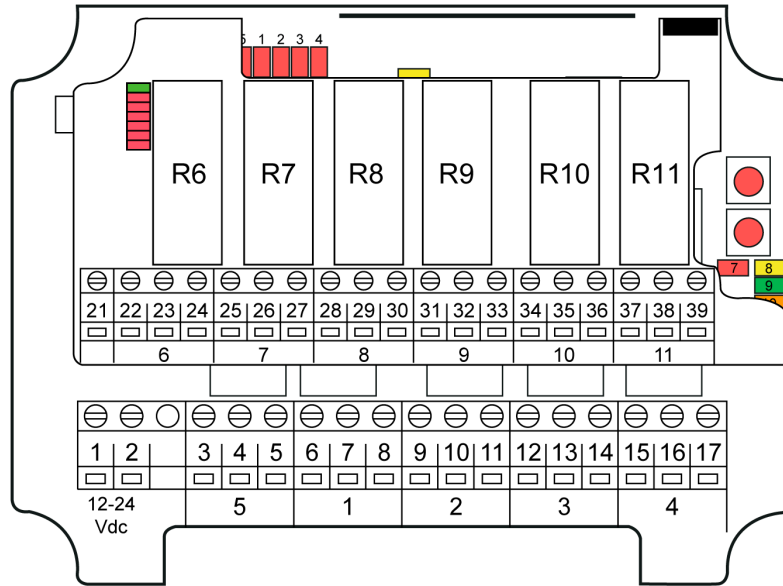

For more details, refer to installation wiring table (see page 30).

ZARB05WSP Wiring

ZARB05WSP receiver is delivered pre-wired with 1.5 m (59 in) cable.

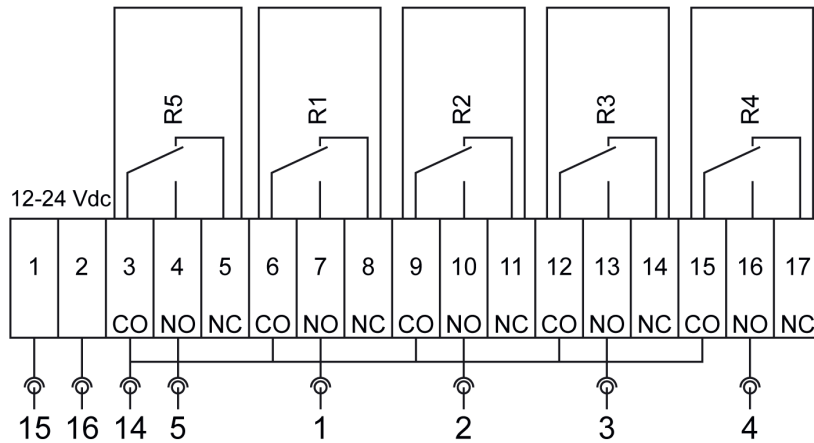

For more details, refer to installation wiring table (see page 30).

ZARB11WSP Wiring

ZARB11WSP receiver is delivered pre-wired with 1.5 m (59 in) cable.

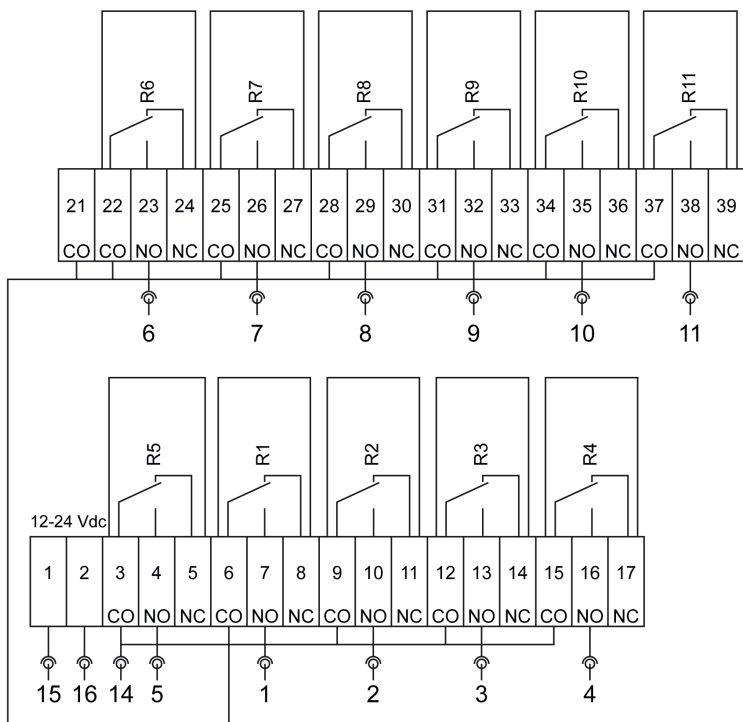

For more details, refer to installation wiring table ([see page 30](#)).

Installation Wiring

Signal		ZARB05WSP Cable no.	ZARB11WSP Cable no.
Power supply / +		15	15
Power supply / -		16	16
Relay R5	Common	14	14
	Output (NO type)	5	5
	Output (NC type)	-	-
Relay R1	Common	-	-
	Output (NO type)	1	1
	Output (NC type)	-	-
Relay R2	Common	-	-
	Output (NO type)	2	2
	Output (NC type)	-	-
Relay R3	Common	-	-
	Output (NO type)	3	3
	Output (NC type)	-	-
Relay R4	Common	-	-
	Output (NO type)	4	4
	Output (NC type)	-	-
Relay R6	Common		-
	Output (NO type)		6
	Output (NC type)		-
Relay R7	Common		-
	Output (NO type)		7
	Output (NC type)		-
Relay R8	Common		-
	Output (NO type)		8
	Output (NC type)		-
Relay R9	Common		-
	Output (NO type)		9
	Output (NC type)		-
Relay R10	Common		-
	Output (NO type)		10
	Output (NC type)		-
Relay R11	Common		-
	Output (NO type)		11
	Output (NC type)		-

NOTE: The cables 12 and 13 are not connected in the receiver.

Relays

 **WARNING**
UNINTENDED EQUIPMENT OPERATION

Power line must be wired and protected with fuse or thermal magnetic switch (ex: Schneider Electric GV2) in compliance with local and national regulatory requirements for the rated current and voltage of the particular equipment.

Failure to follow these instructions can result in death, serious injury, or equipment damage.

Power Supply

ZARB05WSP / ZARB11WSP power supply terminal:

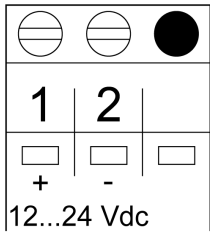

NOTICE

INOPERABLE EQUIPMENT

The ZARB05WSP / ZARB11WSP receiver must be powered with a voltage:

- The power source to the receiver must fulfill the definition of LPS (Limited Power Source) according to EN 60950-1. The maximum available output power should be either 240 VA (fuse protected) or 100 VA (without fuse).
- The ZARB05WSP / ZARB11WSP receiver must be powered with a voltage from 12...24 Vdc.

Failure to follow these instructions can result in equipment damage.

General Wiring Rules

The power supply cables should be cross-sectional conductor area = 1 mm² (AWG 16).

The output cables should be cross-sectional conductor area = 1 mm² (AWG 16).

The power supply cable lengths should not exceed 50 m (164 ft).

The recommended cable diameter in the cable gland is 6...13 mm (0.25...0.50 in).

For more details, refer to Wiring Best Practices (*see page 33*).

Wiring Best Practices

Overview

This section describes the wiring guidelines and associated best practices to be respected when using the system.

DANGER

HAZARD OF ELECTRIC SHOCK, EXPLOSION OR ARC FLASH

- Disconnect all power from all equipment including connected devices prior to removing any covers or doors, or installing or removing any accessories, hardware, cables, or wires except under the specific conditions specified in the appropriate hardware guide for this equipment.
- Always use a properly rated voltage sensing device to confirm that the power is off where and when indicated.
- Replace and secure all covers, accessories, hardware, cables, and wires and confirm that a proper ground connection exists before applying power to the unit.
- Use only the specified voltage when operating this equipment and any associated products.

Failure to follow these instructions will result in death or serious injury.

WARNING

LOSS OF CONTROL

- The designer of any control wiring diagram must consider the potential failure modes of control paths and, for certain critical control functions, provide a means to achieve a safe state during and after a path failure. Examples of critical control functions are emergency stop and overtravel stop, power outage and restart.
- Separate or redundant control paths must be provided for critical control functions.
- System control paths may include communication links. Consideration must be given to the implications of unanticipated transmission delays or failures of the link.
- Observe all accident prevention regulations and local safety guidelines.¹
- Each implementation of this equipment must be individually and thoroughly tested for proper operation before being placed into service.

Failure to follow these instructions can result in death, serious injury, or equipment damage.

¹ For additional information, refer to NEMA ICS 1.1 (latest edition), "Safety Guidelines for the Application, Installation, and Maintenance of Solid State Control" and to NEMA ICS 7.1 (latest edition), "Safety Standards for Construction and Guide for Selection, Installation, and Operation of Adjustable-Speed Drive Systems" or their equivalent governing your particular location.

Wiring Guidelines

The following rules must be applied when wiring the system:

- I/O wiring must be kept separate from the power wiring. Route these 2 types of wiring in separate cable ducting.
- Verify that the operating conditions and environment are within the specification values.
- Use proper wire sizes to meet voltage and current requirements.
- Use copper conductors (highly recommended).

⚠ WARNING
UNINTENDED EQUIPMENT OPERATION
Route I/O cables separately from power cables.
Failure to follow these instructions can result in death, serious injury, or equipment damage.

⚠ WARNING
UNINTENDED EQUIPMENT OPERATION
Power line must be wired and protected with fuse or thermal magnetic switch (ex: Schneider Electric GV2) in compliance with local and national regulatory requirements for the rated current and voltage of the particular equipment.
Failure to follow these instructions can result in death, serious injury, or equipment damage.

Rules for Screw Terminal Block

The following tables show the cable types and wire sizes for a 5.08 mm (0.19 in) pitch screw terminal block:

$\frac{\text{mm}}{\text{in.}}$	$\frac{7}{0.28}$								
mm ²		0.2...2.5	0.2...2.5	0.25...2.5	0.25...2.5	2 x 0.2...1	2 x 0.2...1.5	2 x 0.25...1	2 x 0.5...1.5
AWG		24...14	24...14	23...14	23...14	2 x 24...17	2 x 24...16	2 x 23...17	2 x 20...16
				N•m		0.5...0.6			
Ø 3,5 mm (0.14 in.)				lb-in		4.42...5.31			

The use of copper conductors is required.

The use of cable ends is required.

⚠ DANGER
FIRE HAZARD
Use only the recommended wire sizes for I/O channels and power supplies.
Failure to follow these instructions will result in death or serious injury.

NOTICE
INOPERABLE EQUIPMENT
Do not tighten screw terminals beyond the specified maximum torque (Nm / lb-in.).
Failure to follow these instructions can result in equipment damage.

Section 3.2

Transmitter Front Cover Customization

What Is in This Section?

This section contains the following topics:

Topic	Page
Transmitter Front Cover Customization Creation	36
Transmitter Front Cover Customization Installation	36

Transmitter Front Cover Customization Creation

Overview

The transmitter front cover is customizable by the following ways:

- Standard label accessory ZARC620.
- Do-It-Yourself label ZARC603/04/06/08/10.
- Configurable front cover ZARC600G. ⁽¹⁾

(1) For customization, please contact local Schneider Electric representative agency for technical support.

For more details about the accessories, refer to their Instruction Sheets ([see page 7](#)).

Transmitter Front Cover Customization Installation

Overview

The chosen customization must be installed on the product:

- Install standard labels accessories.
- Install customized label printed by yourself.

For more details about the accessories, refer to their Instruction Sheets ([see page 7](#)).

Chapter 4

Using The Wireless Remote Control System

What Is in This Chapter?

This chapter contains the following sections:

Section	Topic	Page
4.1	Overview	38
4.2	Functional Description	44
4.3	Configuration	47
4.4	Transmitter Battery Replacement	48

Section 4.1

Overview

What Is in This Section?

This section contains the following topics:

Topic	Page
Register and Radio Communication	39
Main Application	40
Button/Relay Assignment	43

Register and Radio Communication

Overview

This part describes how to make the system (transmitter + receiver) operational:

- The transmitter must be registered in the receiver.
- The transmitter communicates with the receiver.

Register

Registering means storing the ID of the transmitter in the receiver.

Up to 8 transmitters can be registered in the receiver.

This functionality allows you to command 1 receiver with several transmitters alternately.

For more details refer to:

- Register the Transmitter in the Receiver (*see page 45*)
- Erase All Transmitters from the Receiver (*see page 45*)

Radio Communication

To communicate, the transmitter must be registered in the receiver first.

Only one transmitter can communicate with a receiver at a time.

A registered transmitter automatically communicates when you press any of the buttons.

Main Application

Overview

This part describes main applications modes:

- Single mode = one transmitter commands one receiver.
- Multi transmitter mode = several transmitters alternately commands one receiver.

Single Mode

Single mode = one transmitter commands one receiver.

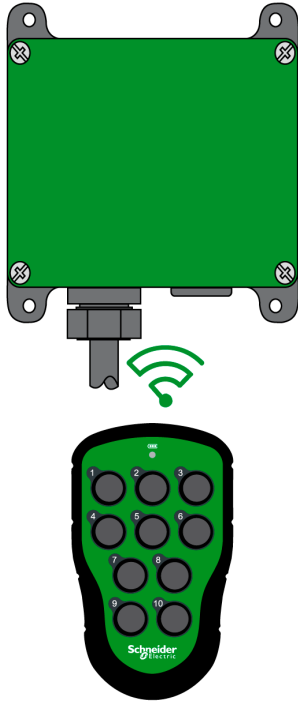

For commissioning, you have to:

- Register the transmitter in the receiver (*see page 45*).
- Power-on the transmitter (*see page 45*).

To control the receiver with the transmitter, power-on the transmitter and press one button of the transmitter.

Multi Transmitter Mode

Multi transmitter mode = several transmitters alternately commands one receiver:

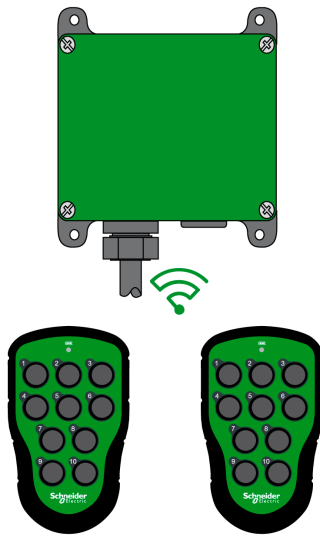

For commissioning, you have to:

- Register the first transmitter in the receiver (*see page 45*).
- Register the second transmitter in the receiver (*see page 45*).

Several transmitters can alternately command one receiver.

To control the receiver with the first transmitter, power-on the first transmitter and press one button.

To control the receiver with the second transmitter:

- Release all the buttons of the first transmitter.
- Power-on the second transmitter.
- Press one button of the second transmitter.

Case A: 2 transmitters used alternately, relays configured as momentary:

Step	Action	Result
1	Press a button of transmitter A.	Corresponding relay is ON.
2	Release button of transmitter A.	Corresponding relay is OFF.
3	Press a button of transmitter B	Corresponding relay is ON
4	Release button of transmitter B.	Corresponding relay is OFF.

Case B: 2 transmitters used alternately, relay 1 configured as latching is OFF:

Step	Action	Result
1	Press button 1 of transmitter A.	Relay 1 is ON.
2	Release button of transmitter A.	Relay 1 stays ON.
3	Press button 1 of transmitter B.	Relay 1 is OFF
4	Release button of transmitter B.	Relay 1 stays OFF.

Case C: 2 transmitters used simultaneously, relay 1 configured as momentary

Step	Action	Result
1	Press and hold the button 1 of transmitter A.	Relay 1 is ON.
2	Press and hold the button 1 of transmitter B.	Relay 1 stays ON (No change).
3	Release the button 1 of transmitter A.	Relay 1 is OFF.
4	Wait around 1 second (until the communication with transmitter B is established).	Relay 1 is ON.
5	Release the button 1 of transmitter B.	Relay 1 is OFF.

Case D: 2 transmitters used simultaneously, relay 1 configured as latching is OFF

Step	Action	Result
1	Press and hold the button 1 of transmitter A.	Relay 1 is ON.
2	Press and hold the button 1 of transmitter B.	Relay 1 stays ON (No change).
3	Release the button 1 of transmitter A.	Relay 1 stays ON.
4	Wait around 1 second (until the communication with transmitter B is established).	Relay 1 becomes OFF.
5	Release the button 1 of transmitter B.	Relay 1 stays OFF.

Button/Relay Assignment

Overview

The transmitter buttons command associated receiver relays.

Button/Relay Assignment

Button No.					Relay		
ZART03	ZART04	ZART06	ZART08	ZART10	ZARB05WSP	ZARB11WSP	
1	1	1	1	1	1	1	
2	2	2	2	2	2	2	
3	3	3	3	3	3	3	
-	4	4	4	4	4	4	
	-	5	5	5	-	5	
		6	6	6		6	
		-	7	7		7	7
			8	8		8	8
			-	9		9	9
		10		10		10	10

ZART04 ZART03/06/08/10

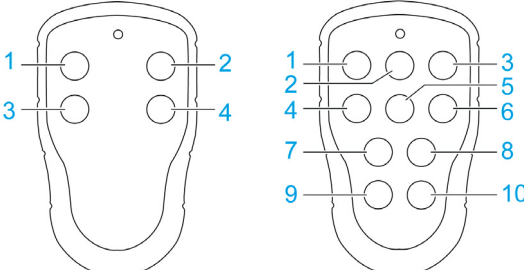

Work relays (only for ZARB11WSP)	Relay 11 is active when any of the relays 1...10 are active
Programmable relay functions	Relay 1...10 can be set to latching (<i>see page 47</i>)
Interlocking	No interlocking
Radio mode	Discontinuous

For more details about relays, refer to the installation wiring description table (*see page 31*).

Section 4.2

Functional Description

What Is in This Section?

This section contains the following topics:

Topic	Page
Register the Transmitter in the Receiver	45
Power-on the Transmitter	45
Power-off the Transmitter	45
Erase All Transmitters from the Receiver	45

Register the Transmitter in the Receiver

Register the Transmitter in the Receiver

WARNING

UNINTENDED EQUIPMENT OPERATION

Only keep the transmitters that you intend to use registered in the receivers.

Failure to follow these instructions can result in death, serious injury, or equipment damage.

For more details, refer to section Register (*see page 39*).

Steps to register the transmitter in the receiver:

Step	Action	Comment
1	Press the receiver Function button.	The function LED lights (red).
2	Press the receiver Select button.	All relay LEDs light (red).
3	Press and keep pressed transmitter buttons 1 and 2.	All relay LEDs light (red). All relay LEDs flash 2 times (red).
4	Release transmitter buttons 1 and 2.	All relay LEDs flash 1 time (red). The transmitter is registered.

If no transmitter is found within approximately 10 seconds, the receiver exits to normal operation.

Power-on the Transmitter

Power-on the Transmitter

Steps to power-on the transmitter:

Step	Action	Comment
1	Push the power switch to "I" position.	-

When you press any button on the transmitter, the top LED lights:

- green when the battery capacity is good.
- red when the battery capacity is poor.

When starting the transmitter, it is ready to control the receiver if:

- The transmitter is registered in the receiver
- No other transmitter is communicating with the receiver

Power-off the Transmitter

Power-off the Transmitter

Steps to power-off the transmitter:

Step	Action	Comment
1	Release all buttons on the transmitter.	All relays of the receiver go off.
2	Push the power switch to "O" position.	-

Erase All Transmitters from the Receiver

Erase All Transmitters from the Receiver

An erased transmitter cannot communicate with the receiver until it has been registered in the receiver again.

Steps to erase all transmitters from the receiver:

Step	Action	Comment
1	Press the receiver Function button.	The function LED lights (red).
2	Press the receiver Select button. Keep pressed at least 4 seconds.	All relay LEDs light (red). All relay LEDs go out.
3	Release the receiver Select button.	All transmitters are erased from the receiver.

If the function LED flashes (red), one or more transmitters are still registered in the receiver.

Section 4.3

Configuration

Momentary or Latching Relay Functions

Overview

Relays of the receiver can be set in to functionality types:

- **Momentary relay functionality:** The relay remains active while a button on the transmitter is pressed. When the button is released the relay deactivates.
- **Latching relay functionality:** The relay becomes active when a button on the transmitter is pressed. The relay remains active until the button is pressed again.

The receiver is configured to momentary relay functionality by default.

Momentary or Latching Relay Functions

NOTE: All the relays are momentary relay by default.

 WARNING
UNINTENDED EQUIPMENT OPERATION
Before changing these settings, make sure that all relays are deactivated.
Failure to follow these instructions can result in death, serious injury, or equipment damage.

Steps to set latching or momentary functionality:

Step	Action	Comment
1	Press the Function button twice.	LED 8 lights (yellow). The relay LEDs light (red).
2	Press the Select button to enter the settings menu for switching relay functionality.	The relay LEDs flash (red) to indicate that a latching or momentary functionality can be set to the corresponding relays.
3	Press the Function button to set latching or momentary functionality.	LED 8 (yellow) off = momentary relay functionality LED 8 (yellow) on = latching relay functionality
4	Press the Select button to move to the next available relay.	-
5	Press the Select button to move through all available relays.	The receiver exits the settings menu and restarts.

Section 4.4

Transmitter Battery Replacement

Transmitter Battery

Replace Batteries

⚠ WARNING

BATTERY LIFESPAN, RISK OF EXPLOSION AND FIRE

- Do not recharge the batteries. Attempts to recharge may cause rupture or hazardous liquids to leak, which will corrode the equipment.
- Do not touch electronic components to avoid electrostatic discharge.

Failure to follow these instructions can result in death, serious injury, or equipment damage.

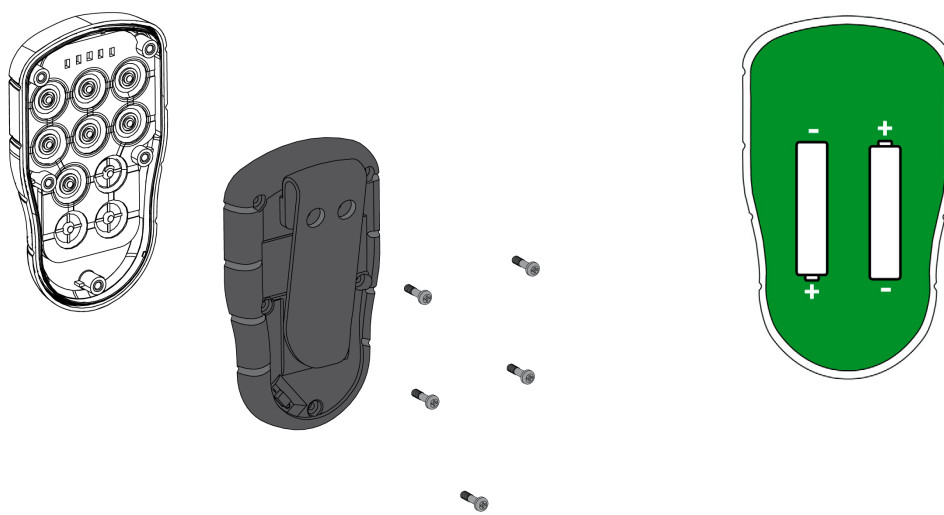

Step	Action
1	Remove the back of the transmitter by unscrewing the 5 screws.
2	Replace the 2 x 1.5 V AAA / LR03 batteries. Use alkaline batteries for optimal performance.
3	Screw the back of the transmitter into place (torque = 0.24...0.34 Nm (2.17...3.04 lb.in))

Chapter 5

Certifications and Standards

Certifications and Standards

Local Standards and Certifications

Schneider Electric submitted this product for independent testing and qualification by third party listing agencies.

Criteria	Description
CE marking	Machinery directive 2006/42/EC Low voltage directive 2006/95/EC EMC directive 2004/108/EC R&TTE directive 1999/05/EC
Low voltage equipment	EN 50178

RADIO Specification

Specification	Details	Value
Frequency of radio communication	International frequency range	2425 MHz
Radio range	In free field	> 300 m (984 ft)
	In industrial environment	Up to 50 m (164 ft) typical
Antenna	-	Internal

FCC USA Compliance Statement

This device complies with part 15 of the FCC Rules and Industry Canada licence-exempt RSS standard(s). Operation is subject to the following two conditions:

- 1) This device may not cause harmful interference, and
- 2) This device must accept any interference received, including interference that may cause undesired operation.

Le présent appareil est conforme aux CNR d'Industrie Canada applicables aux appareils radio exempts de licence. L'exploitation est autorisée aux deux conditions suivantes :

- 1) *l'appareil ne doit pas produire de brouillage, et*
- 2) *l'utilisateur de l'appareil doit accepter tout brouillage radioélectrique subi, même si le brouillage est susceptible d'en compromettre le fonctionnement.*

Changes or modifications not expressly approved by the party responsible for compliance could void the user's authority to operate the equipment. This equipment has been tested and found to comply with the limits for a Class B digital device, pursuant to part 15 of the FCC Rules. These limits are designed to provide reasonable protection against harmful interference in a residential installation. This equipment generates, uses and can radiate radio frequency energy and, if not installed and used in accordance with the instructions, may cause harmful interference to radio communications. However, there is no guarantee that interference will not occur in a particular installation. If this equipment does cause harmful interference to radio or television reception, which can be determined by turning the equipment off and on, the user is encouraged to try to correct the interference by one or more of the following measures:

- Reorient or relocate the receiving antenna.
- Increase the separation between the equipment and receiver.
- Connect the equipment into an outlet on a circuit different from that to which the receiver is connected.
- Consult the dealer or an experienced radio/TV technician for help.

The receiver complies with FCC's radiation exposure limits set forth for an uncontrolled environment under the following conditions:

- 1) This equipment should be installed and operated such that a minimum separation distance of 20 cm is maintained between the radiator (antenna) and user's/nearby person's body at all times.
- 2) This transmitter must not be co-located or operating in conjunction with any other antenna or transmitter.

The transmitter with its antenna complies with FCC's radiation exposure limits set forth for an uncontrolled environment. To maintain compliance, follow the instructions below:

- 1) This transmitter must not be co-located or operating in conjunction with any other antenna or transmitter.
- 2) Avoid direct contact to the antenna, or keep contact to a minimum while using this equipment.

IC Canada Compliance Statement

This product complies with Industry Canada's licence-exempt RSSs. Operation is subject to the following two conditions:

- 1) This device may not cause interference; and
- 2) This device must accept any interference, including interference that may cause undesired operation of device.

Le présent appareil est conforme aux CNR d'Industrie Canada applicables aux appareils radio exempts de licence. L'utilisation de cet appareil est soumise aux deux conditions suivantes :

- 1) l'appareil ne doit pas produire d'interférence nuisible, et
- 2) l'appareil doit accepter toute interférence reçue, y compris celle susceptible d'affecter son fonctionnement.

Any changes or modifications not expressly approved by Schneider Electric could void the user's authority to operate the equipment.

Chapter 6

Diagnostic

Diagnostic

Receiver LEDs

LEDs of the ZARB••WSP receivers:

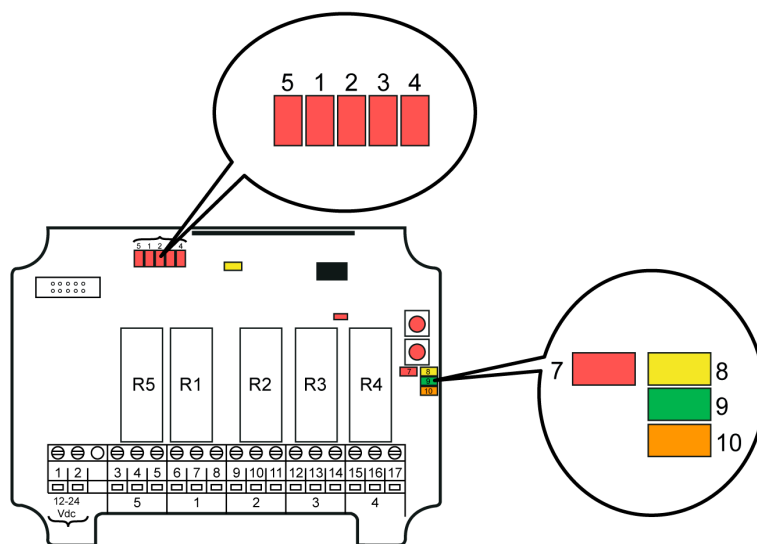

1...5 Relay LEDs
7...10 Function LEDs

The receivers have Function LEDs:

LED	Color	OFF	ON	Indicates
7	Red	✓		No transmitter is registered.
			✓	Flashes once, at 0.5 Hz: One or more transmitters are registered. No radio transmission established.
			✓	Radio transmission established.
8	Yellow		✓	Receiving a radio packet from a transmitter other than a Harmony Pocket Remote.
8	Yellow		✓	Receiving a radio packet from a transmitter set to the radio mode different from that of a receiver.
9	Green		✓	
8	Yellow		✓	Receiving a radio packet from a transmitter that is not registered.
10	Orange		✓	
9	Green		✓	Receiving a radio packet, low signal (RSSI).
10	Orange		✓	Receiving a radio packet from unknown transmitter.
9	Green		✓	Receiving a radio packet with wrong configuration.
10	Orange		✓	
8	Yellow		✓	Receiving a radio packet from a registered transmitter. The receiver is already controlled by another registered transmitter.
9	Green		✓	
10	Orange		✓	

Error Codes

If an error occurs, all Function LEDs flash. At the same time, one or more Relay LEDs lights up. Note the Relay LEDs that light up and contact your Schneider Electric representative for assistance.

Chapter 7

Maintenance

Maintenance

Cleaning Precautions

<i>NOTICE</i>
EQUIPMENT DAMAGE <ul style="list-style-type: none">• Do not use paint thinner, organic solvents, or a strong acid compound to clean the equipment.• Repairs and maintenance must be carried out by qualified personnel• Only use spare parts from Schneider Electric• Contact your representative for service or any other assistance• Keep the product in a clean, dry place• Keep contacts clean• Wipe off dust using a slightly damp, clean cloth Failure to follow these instructions can result in equipment damage.

Periodic Check Points

Periodically check point for the receiver: check the good terminal block tightening.



A

AWG

(American wire gauge) The standard that specifies wire section sizes in North America

C

Continuous radio mode

In continuous radio mode, the transmitter continuously transmits when it is powered-on.

E

EMC

ElectroMagnetic Compatibility

EN

EN identifies 1 of many European standards maintained by CEN (*European Committee for Standardization*), CENELEC (*European Committee for Electrotechnical Standardization*), or ETSI (*European Telecommunications Standards Institute*).

F

Function relay

Standard relay, controlled by the buttons on the transmitter.

I

ID

IDentification.

IEC

(International Electrotechnical Commission) A non-profit and non-governmental international standards organization that prepares and publishes international standards for electrical, electronic, and related technologies.

Interlocking

Prevents a component from functioning when another component is functioning or operating in a particular way.

IP

(Ingress Protection) The protection classification according to IEC 60529.

L

Latching relay functionality

The relay becomes active every time you press a button and remains active until the button is pressed again.

LED

(Light Emitting Diode) An indicator that illuminates under a low-level electrical charge.

M

Momentary relay functionality

The relay is active while a button is pressed on the transmitter. When the button is released, the relay will no longer be active.

MTTF

(Mean Time To Failure)

N

NC
(Normally Closed) A contact pair that closes when the actuator is de-energized (no power is applied) and opens when the actuator is energized (power is applied).

NEMA
(National Electrical Manufacturers Association) The standard for the performance of various classes of electrical enclosures. The NEMA standards cover corrosion resistance, ability to help protect from rain, submersion, and so on. For IEC member countries, the IEC 60529 standard classifies the ingress protection rating for enclosures.

NO
(Normally Open) A contact pair that opens when the actuator is de-energized (no power is applied) and closes when the actuator is energized (power is applied).

P

PFD
(Probability of Failure on Demand)

PFH
(Probability of Failure per Hour)

U

UL
(Underwriters Laboratories) A US organization for product testing and safety certification.

W

Work relay
Relay active when any other specified relay(s) on the receiver is/are active.

Z

Zero position check
Security function ensuring that potentially active buttons/joysticks upon start up or lost/found radio links must be in the zero position before the system can be used to avoid unplanned movements of the controlled object