

# WILL 1600XL

PIED HAUT AVEC ROULETTES POUR ÉCRAN PLAT  
ROLLING STAND ALONE FOR FLAT TV SCREEN

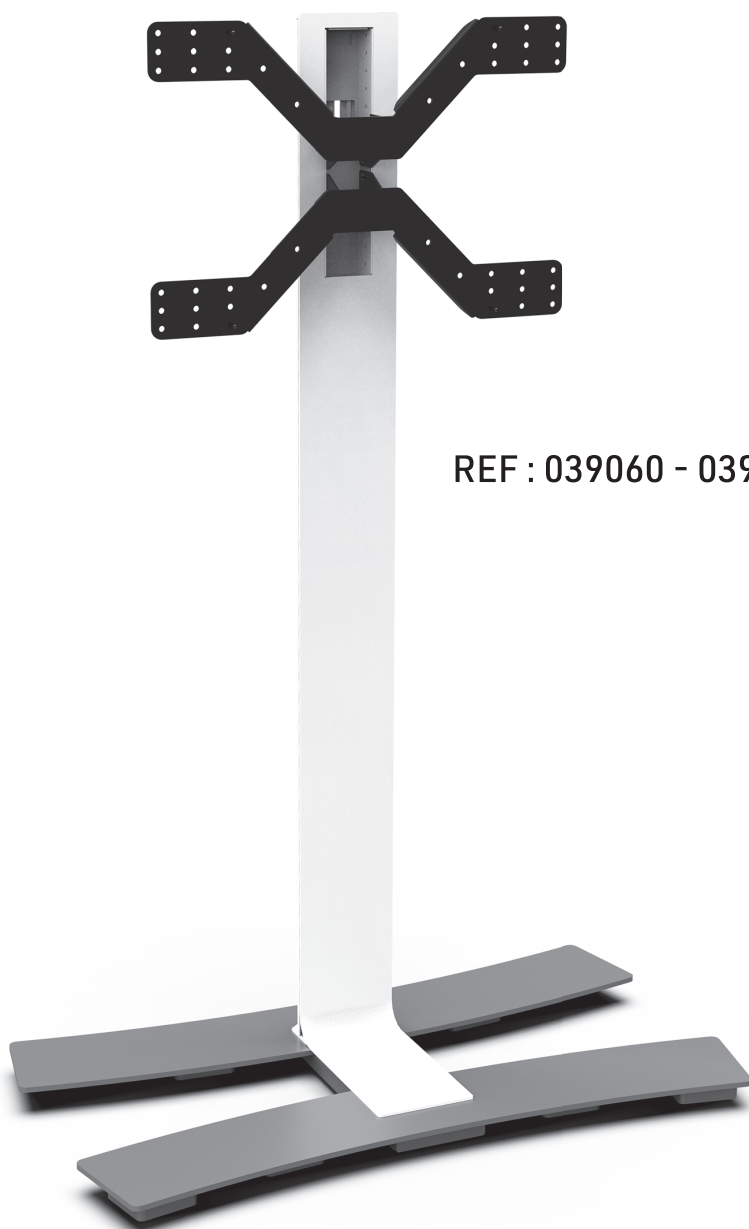

v3.1



REF : 039060 - 039070

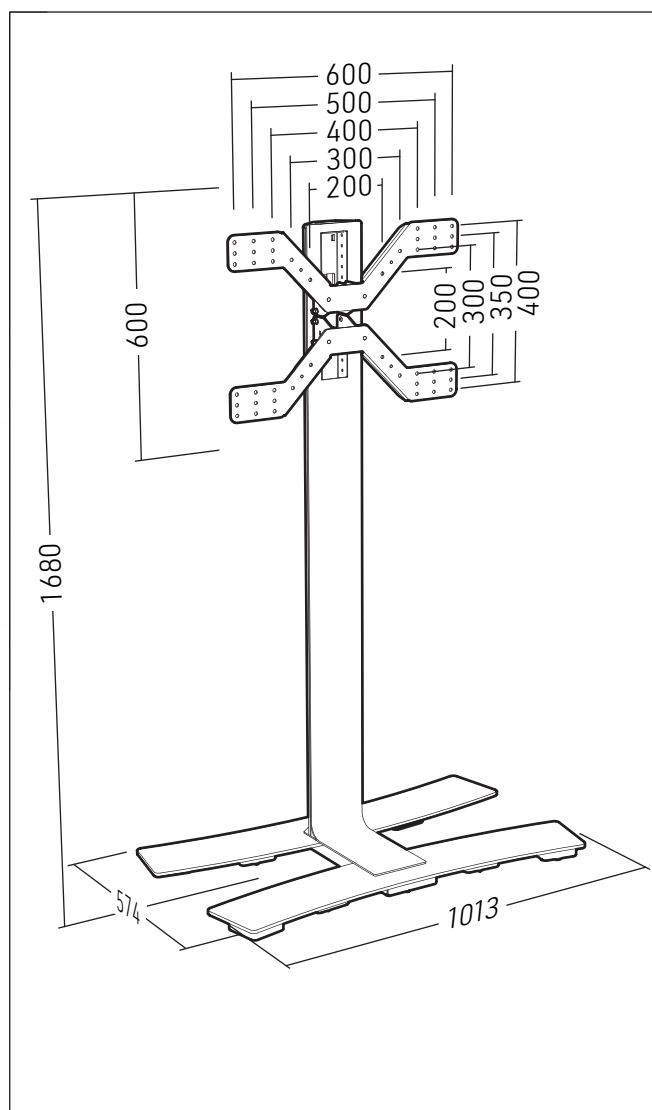

**XXL**

**40"-80"**

101-203 cm

**65 KG**

ÉPAISSEUR ÉCRAN MAXI 100 MM  
FOR SCREENS MAX 100 MM DEEP



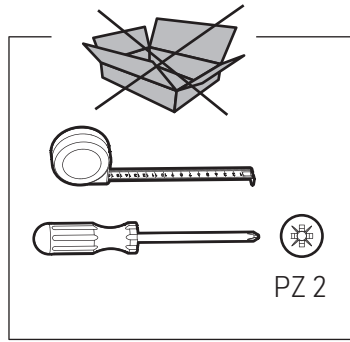
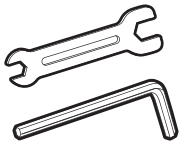
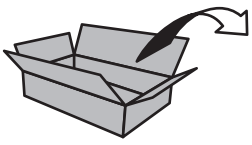

PZ 2

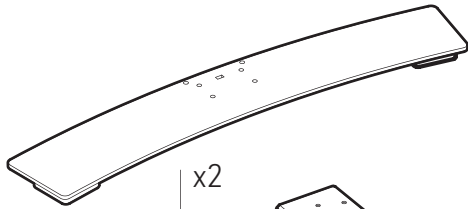

x2

A

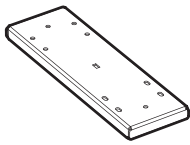

x1

B



x10

C



x1

D



x2

E



x2

F

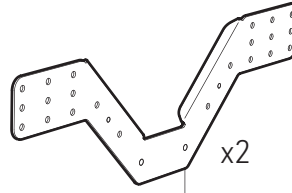

x2

G

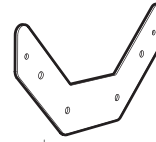

x2

H



x8

I



x12

J



x12

K

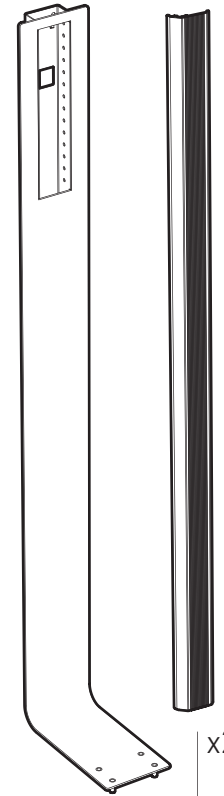

x1

L

x2

M

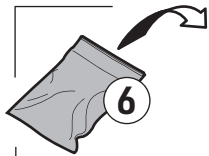

echelle- scale 1:1

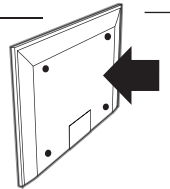

x4

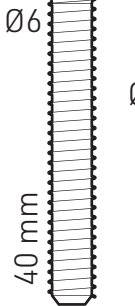
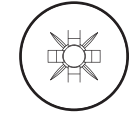

x4

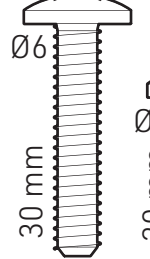
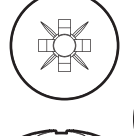

x4



x4



x4

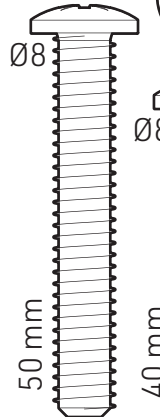

x4

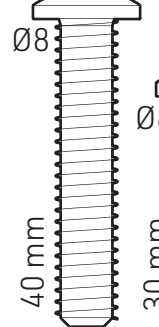
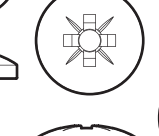

x4

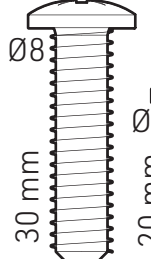
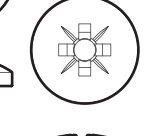

x4



x4

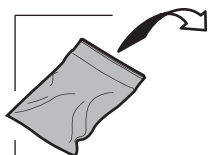
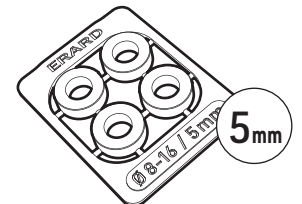
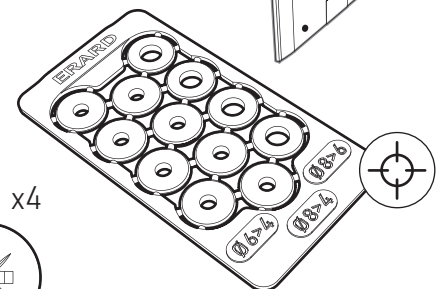

KIT TV ADAPT+

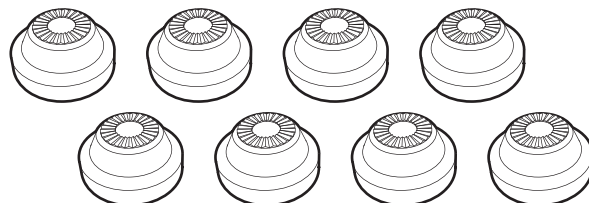

1

A x2 + B + L + K x8

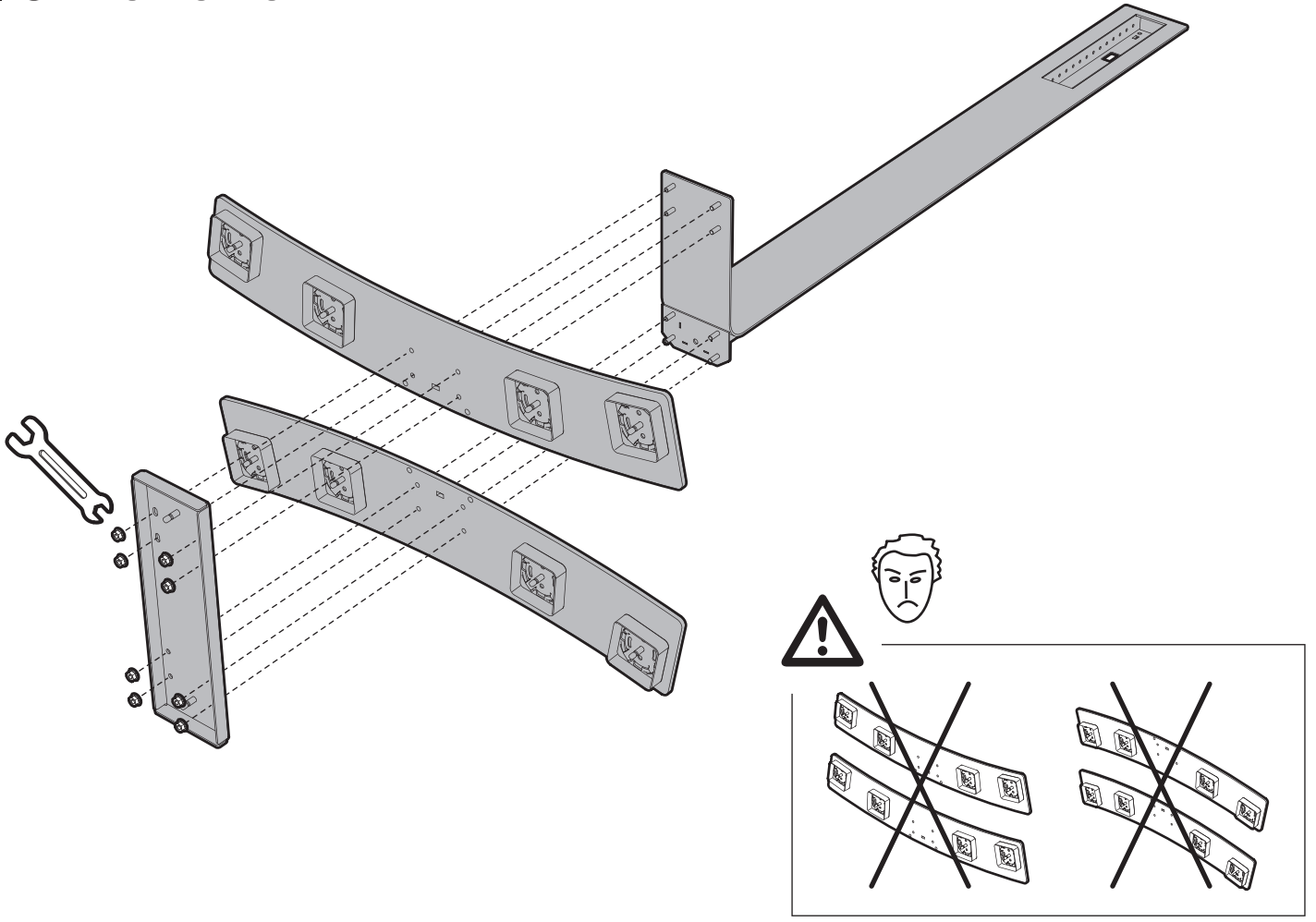

2

C x10

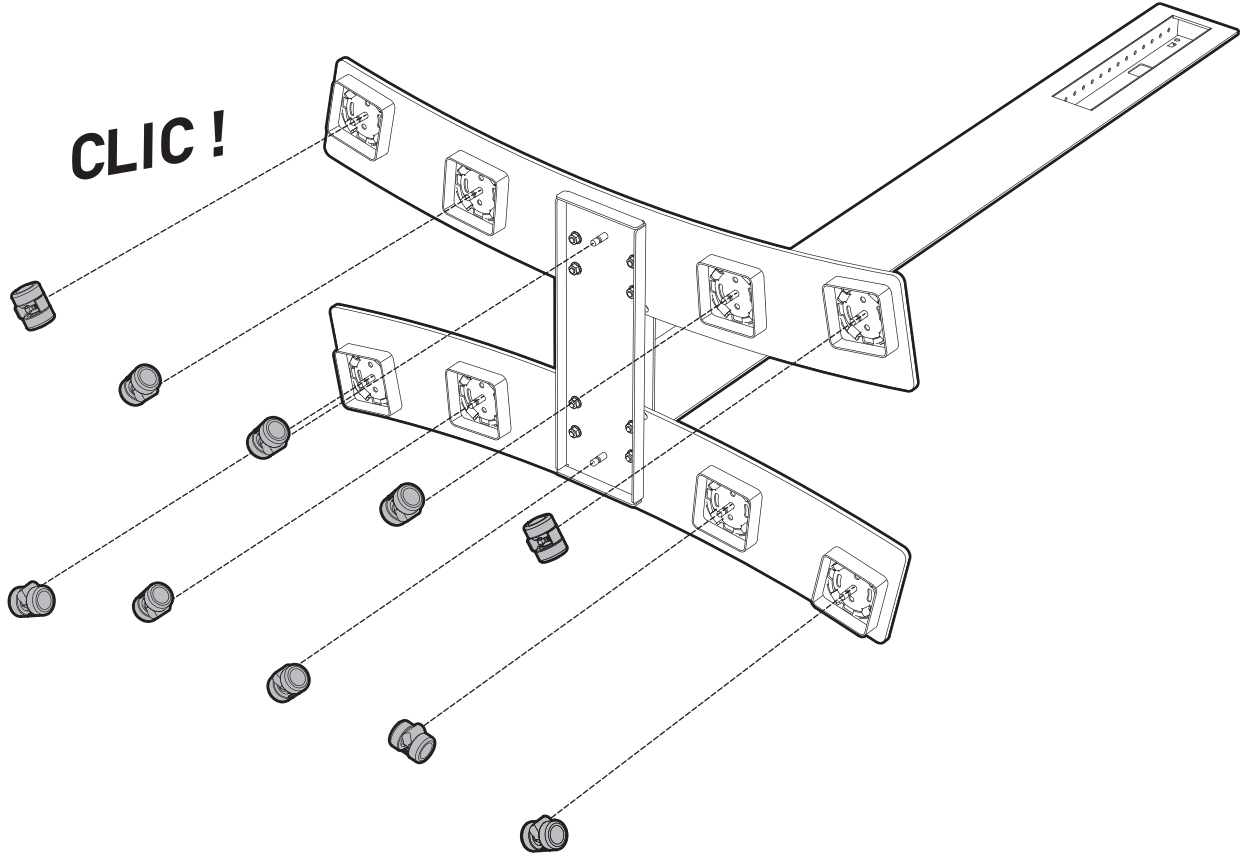

3 (G) x2 + (H) x2 + (J) x4

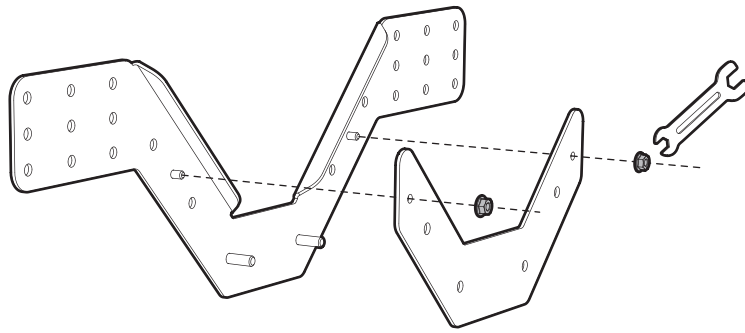





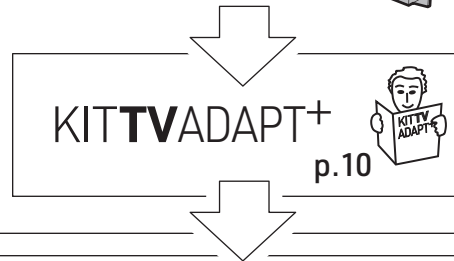
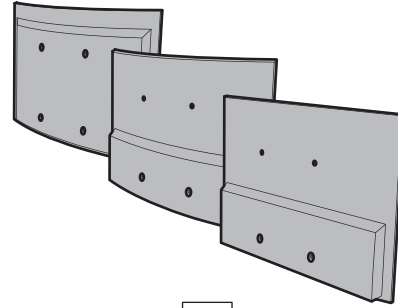
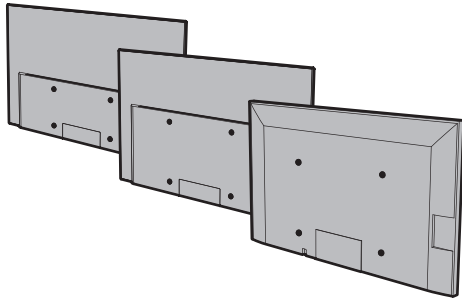

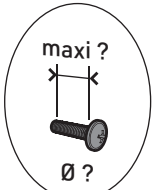

x2

4 ?



5 (6)



-  15 mm
-  20 mm
-  25 mm
-  30 mm
-  35 mm
-  40 mm
-  45 mm
-  50 mm

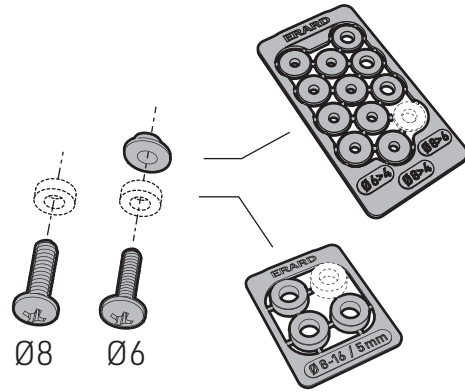

6 ?

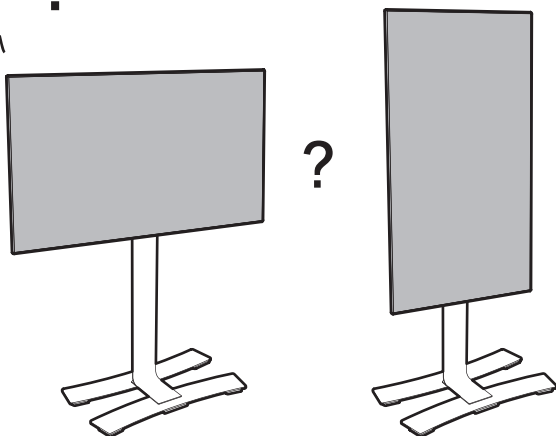

7 ? H=? L=?

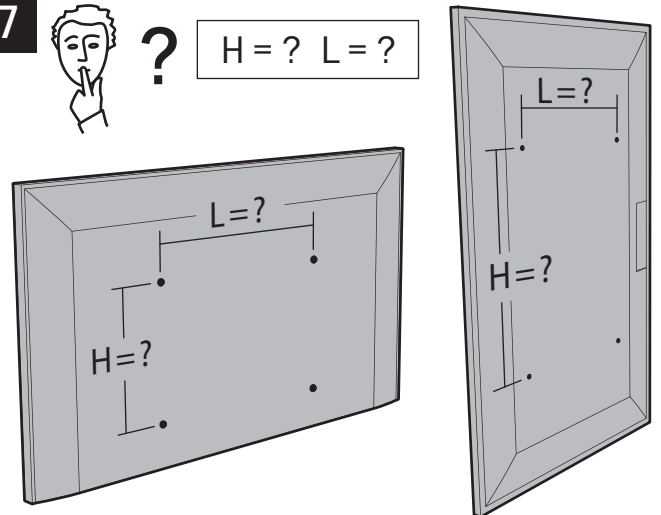



VESA = L x H

L \ H	200	300	400	500	600
100	<b>B</b>	<b>B</b>	<b>B</b>	<b>B</b>	<b>B</b>
150	<b>B</b>	<b>B</b>	<b>B</b>	<b>B</b>	<b>B</b>
200	<b>ABC</b>	<b>AB</b>	<b>B</b>	<b>B</b>	<b>B</b>
300	<b>AB</b>	<b>ABC</b>	<b>AB</b>	<b>AB</b>	<b>AB</b>
400	<b>A</b>	<b>A</b>	<b>ABC</b>	<b>AB</b>	<b>AB</b>
500		<b>AC</b>	<b>AC</b>	<b>A</b>	<b>A</b>
600		<b>C</b>	<b>AC</b>	<b>A</b>	<b>A</b>

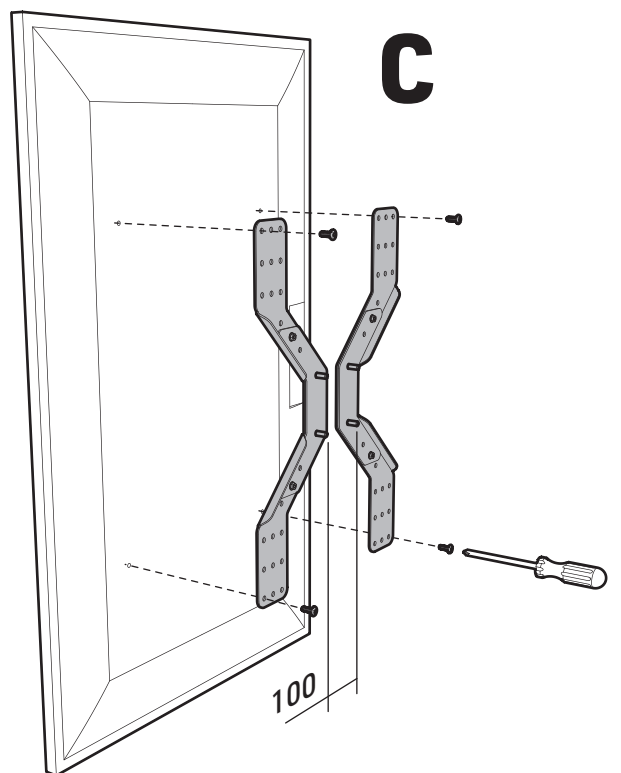
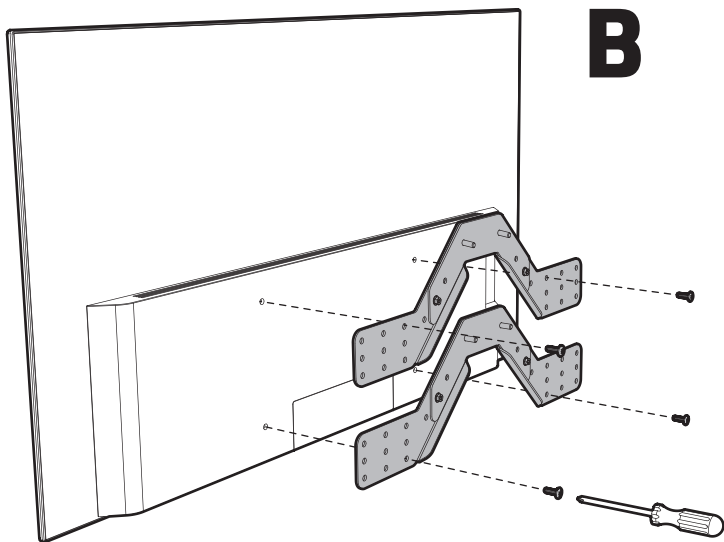
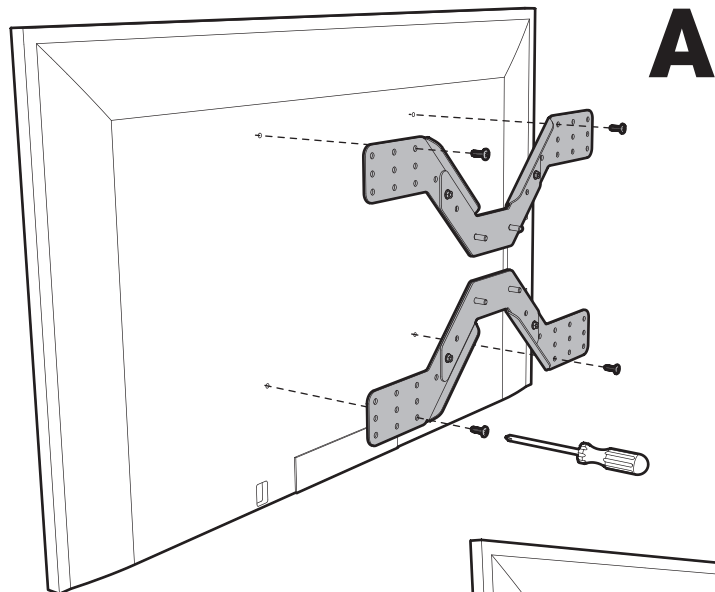

9

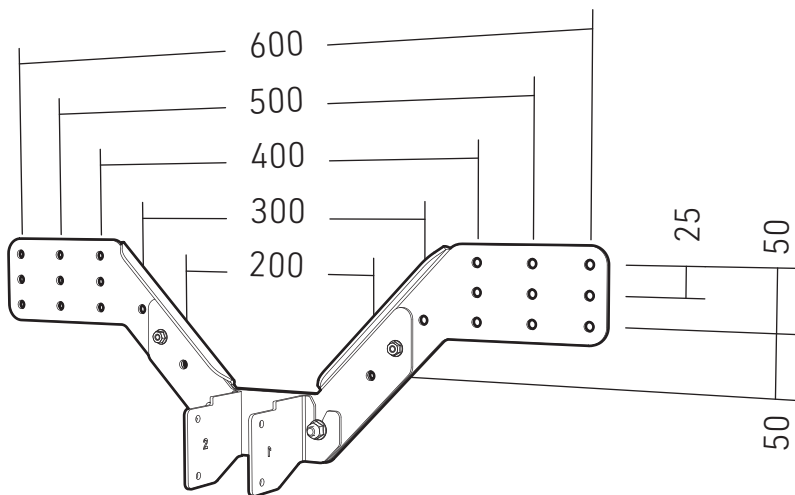
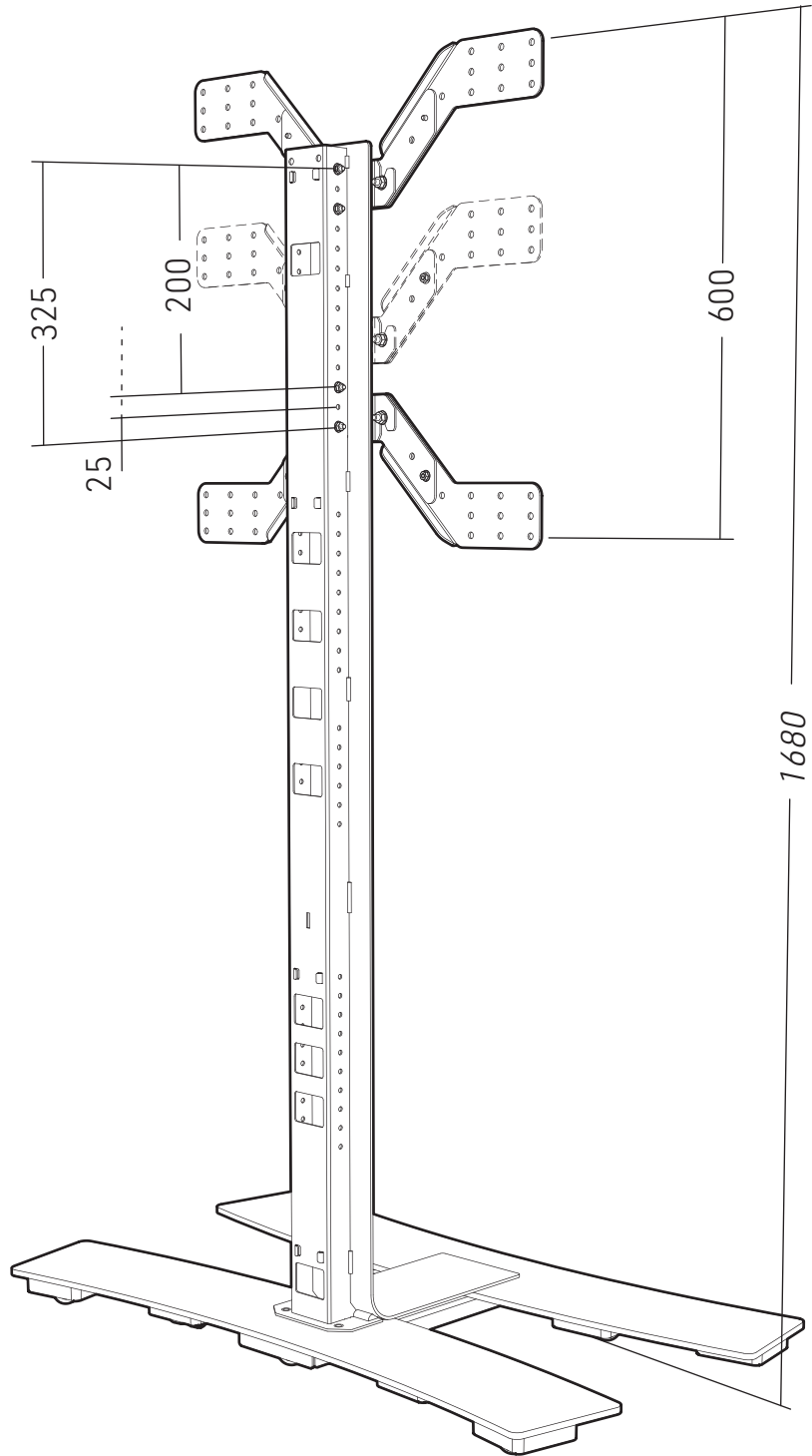
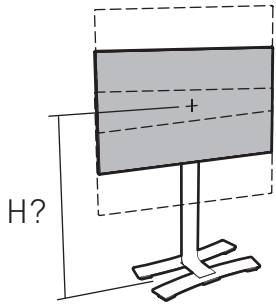

10

(E) x2 + (F) x2 + (I) x8 + (J) x8



**A**

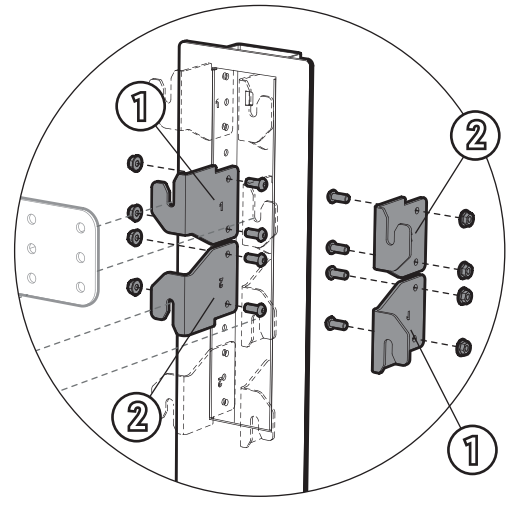
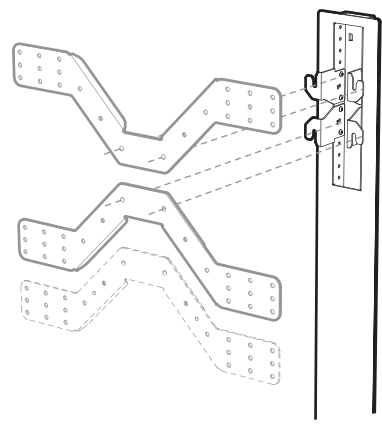

**B**

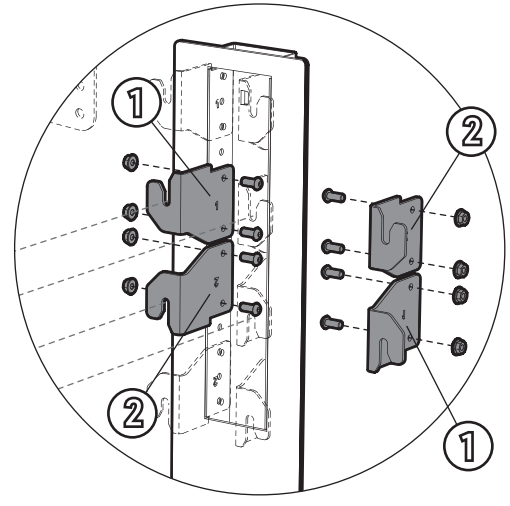
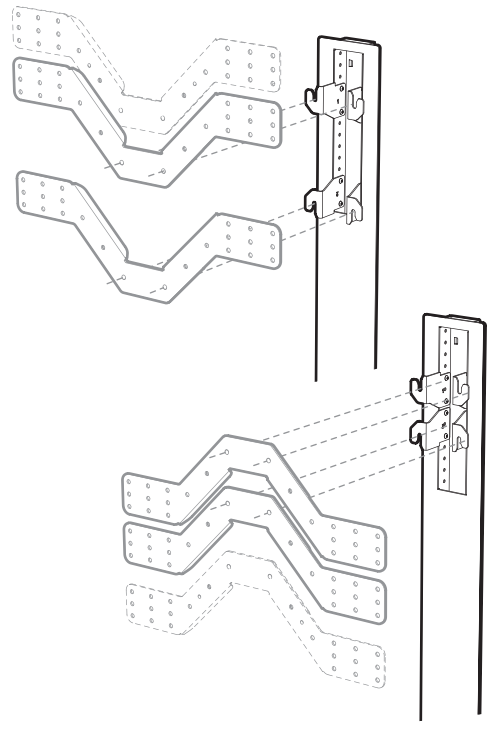

**C**

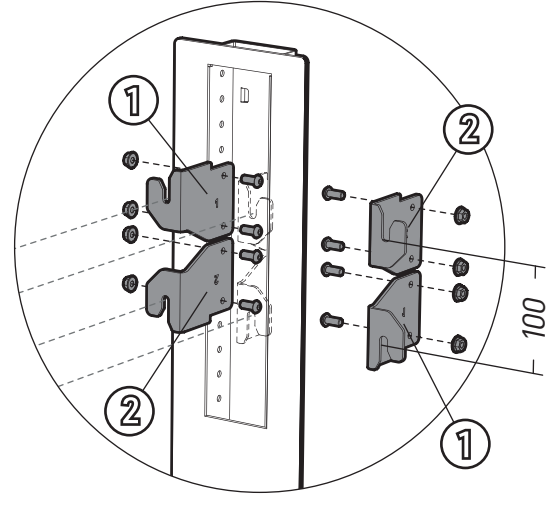
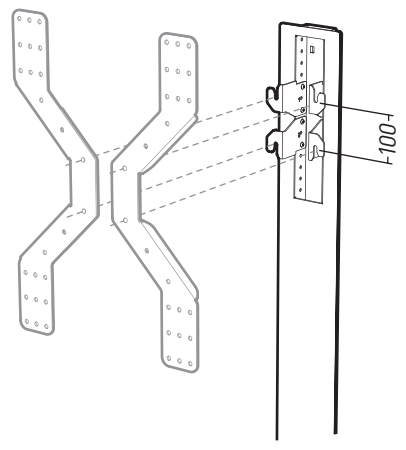

11 (K) x2

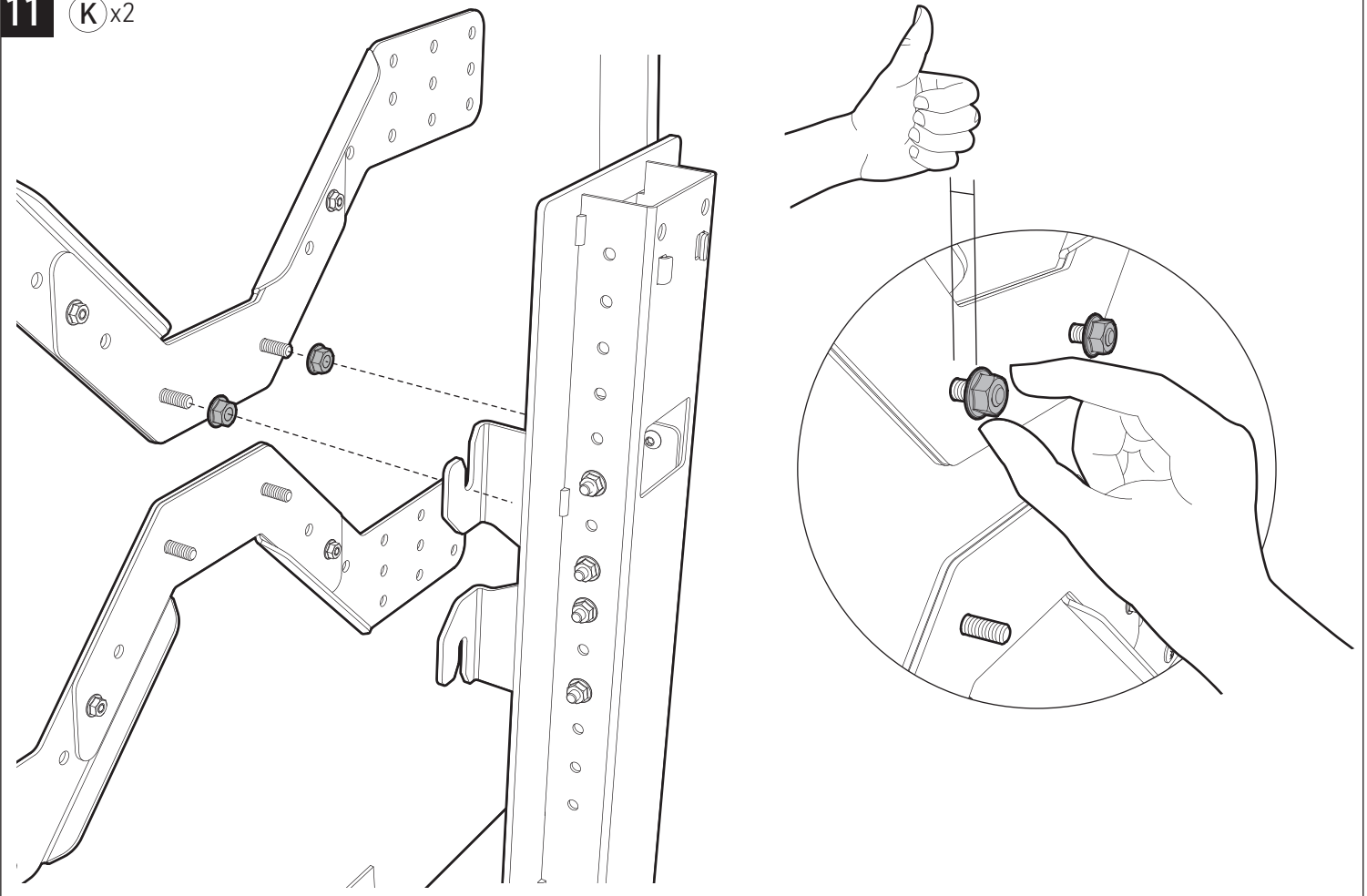

12 (K) x2

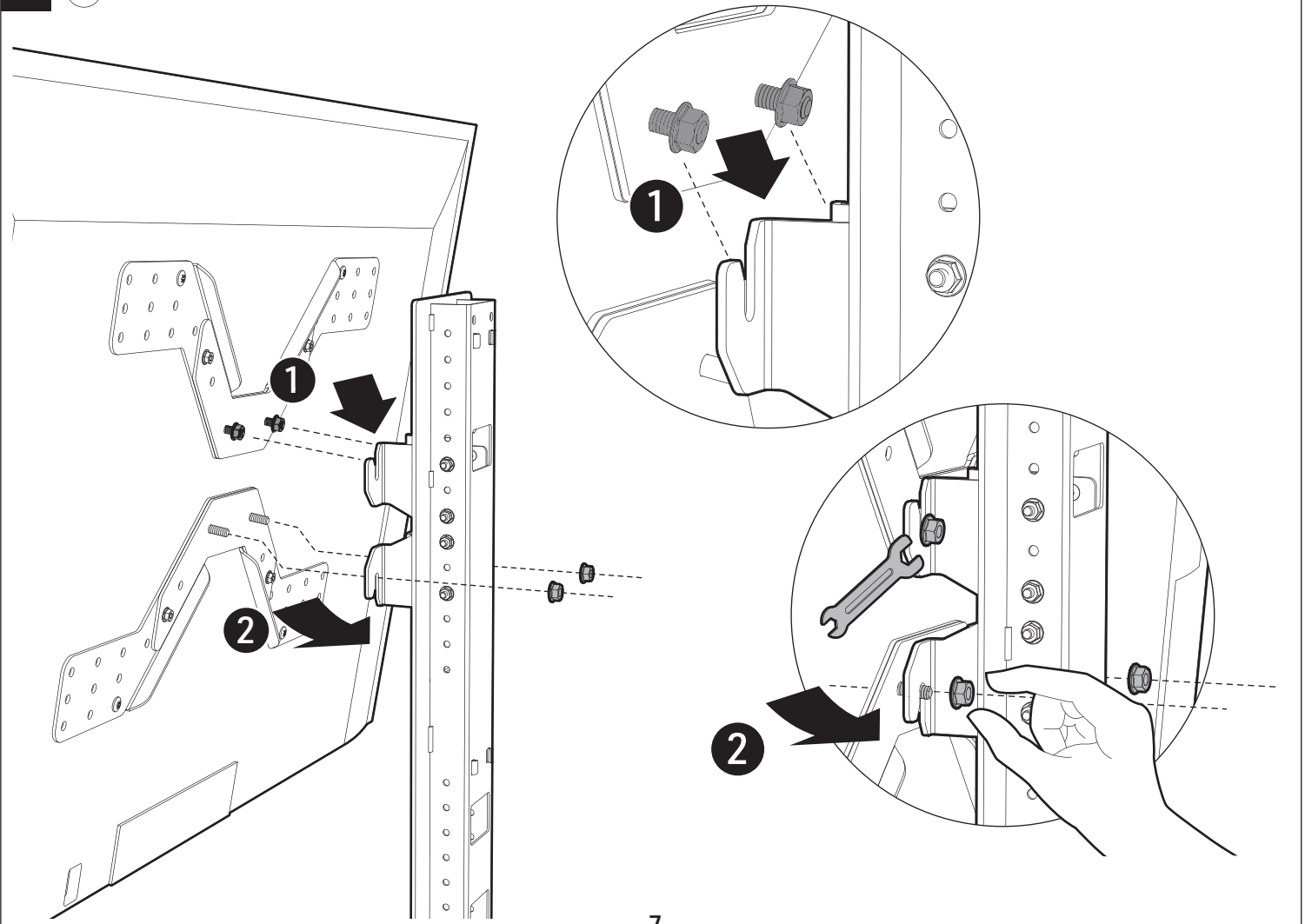

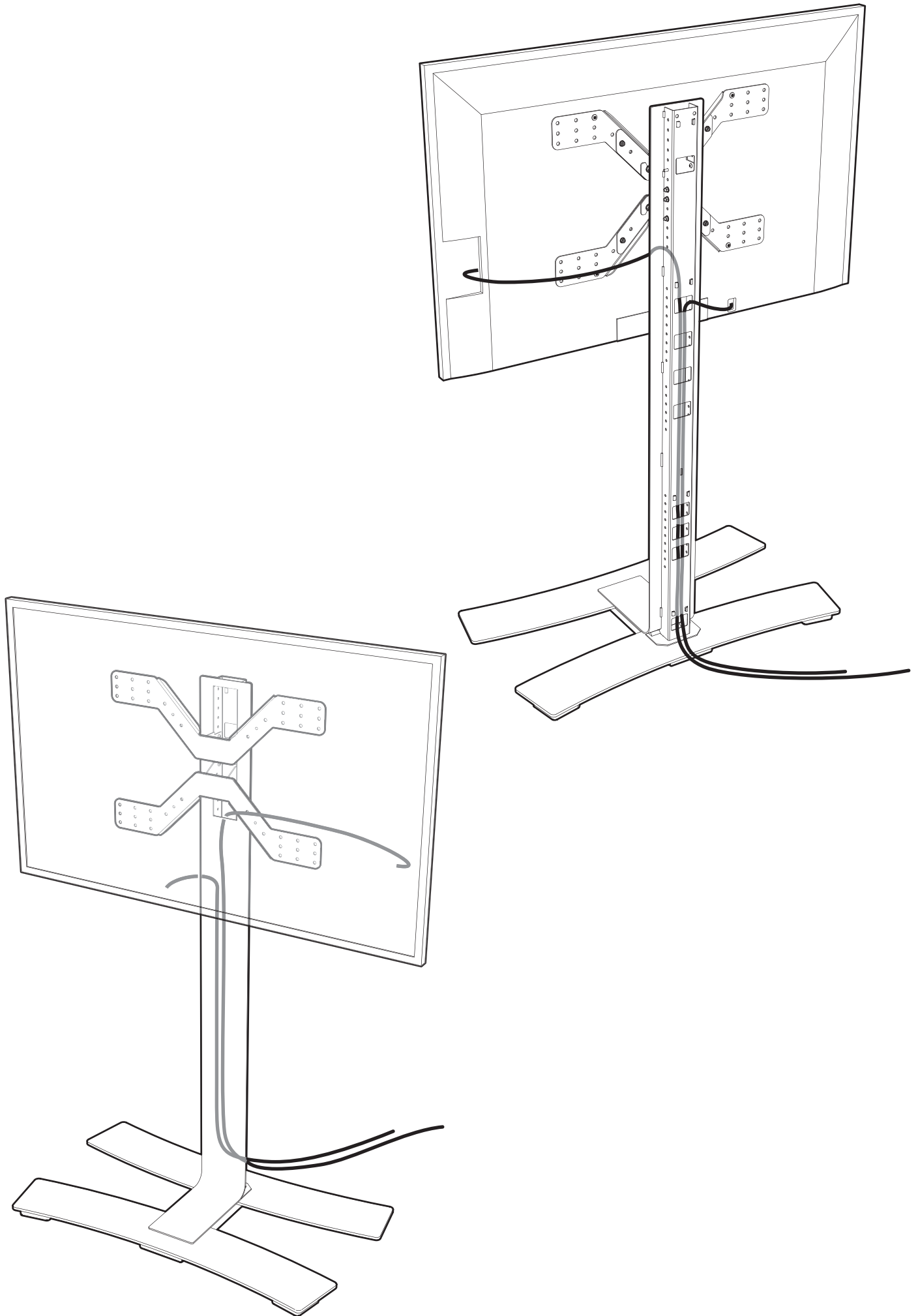

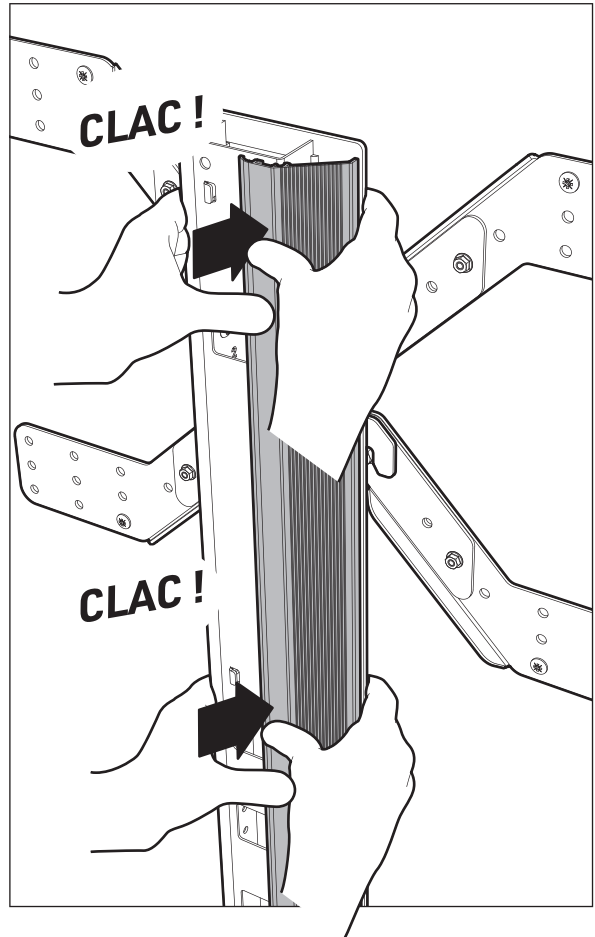
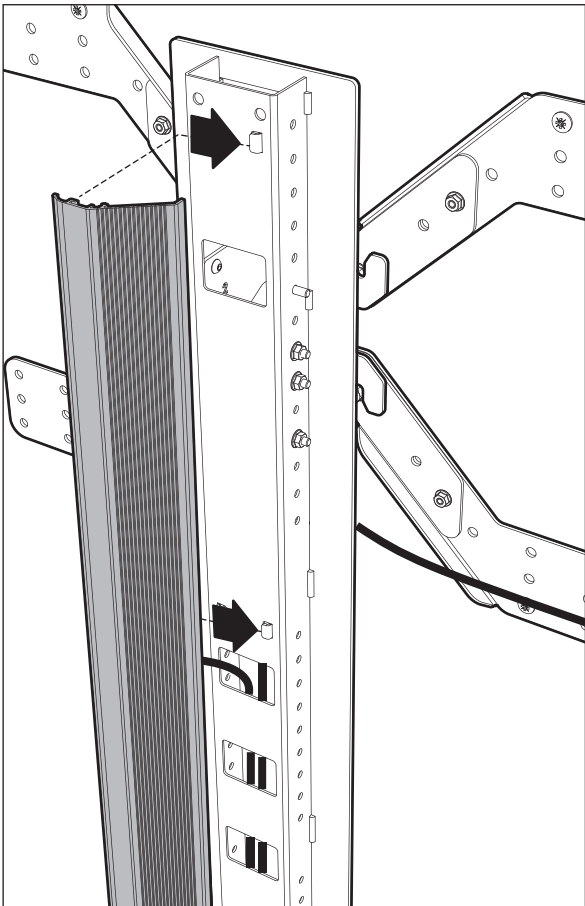
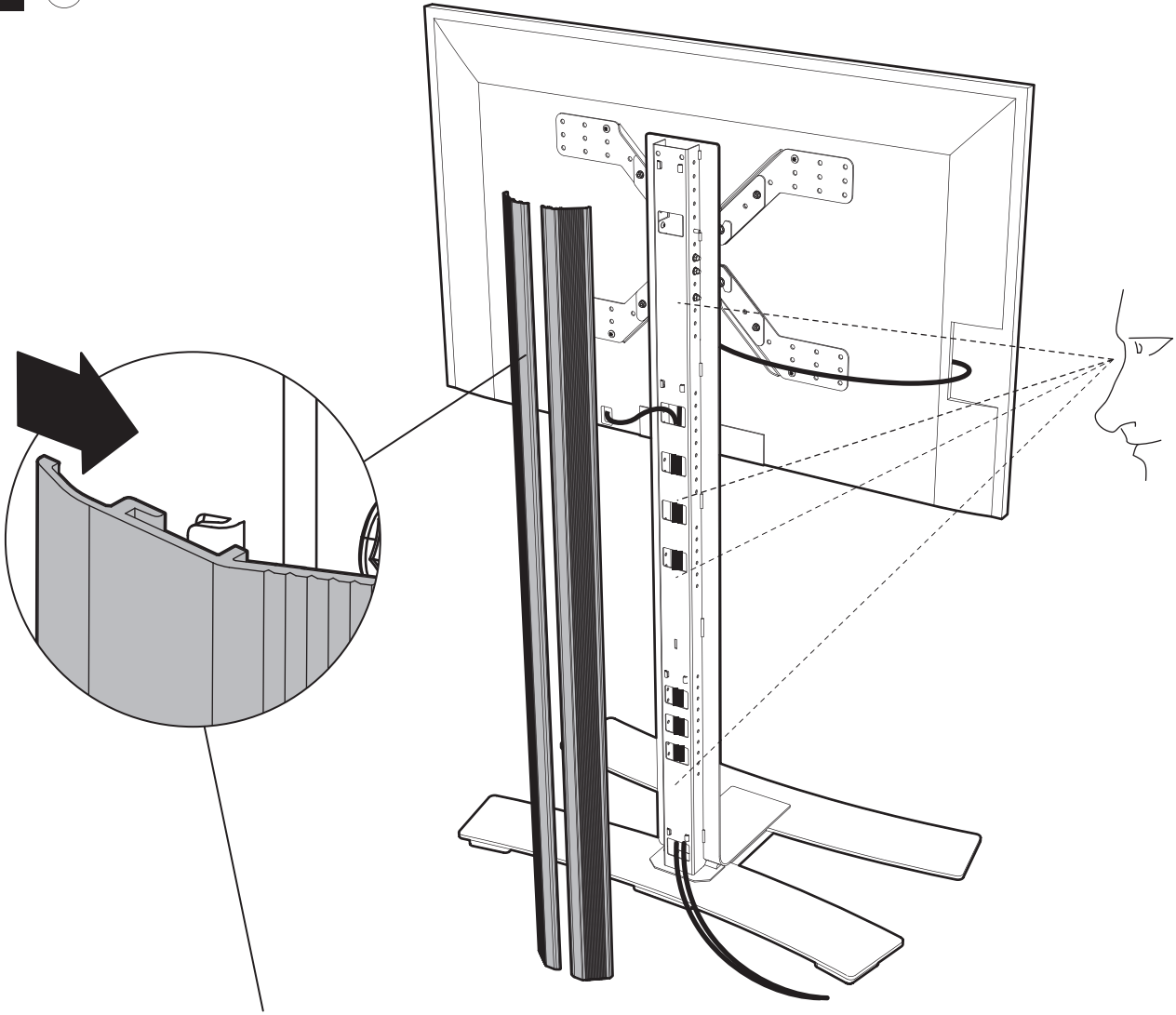

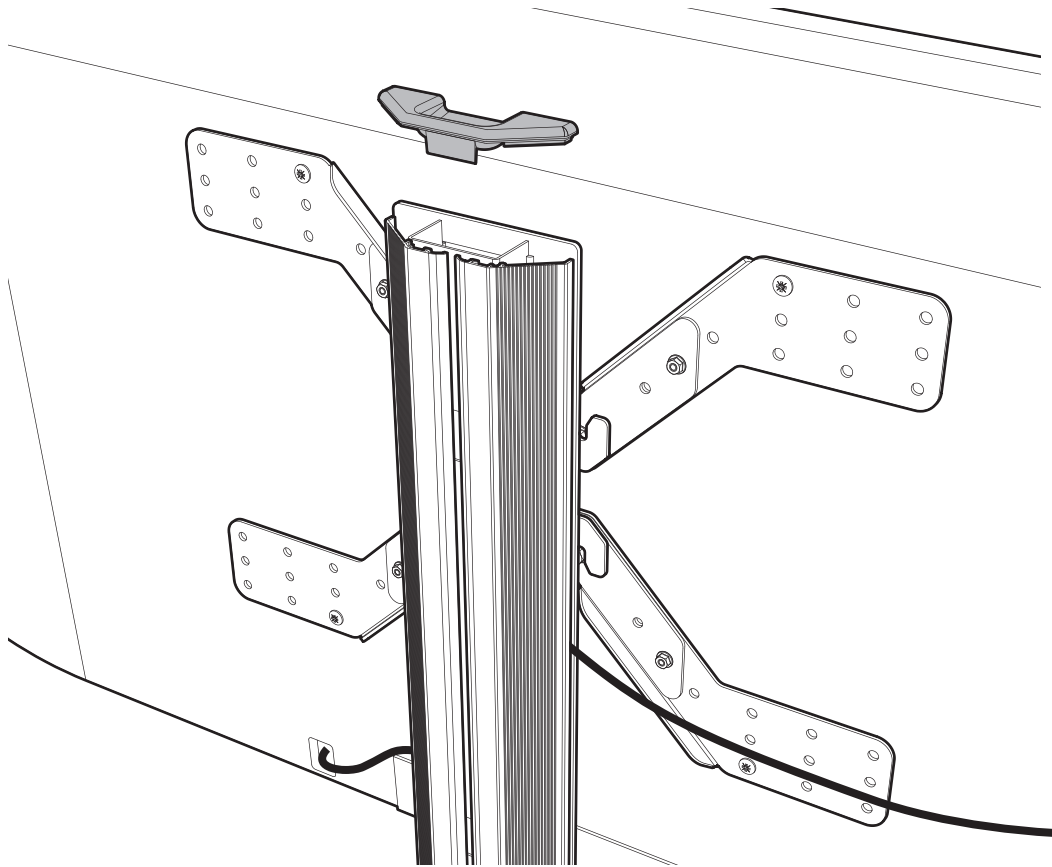

## OPTIONS

ref. 039080  
039090

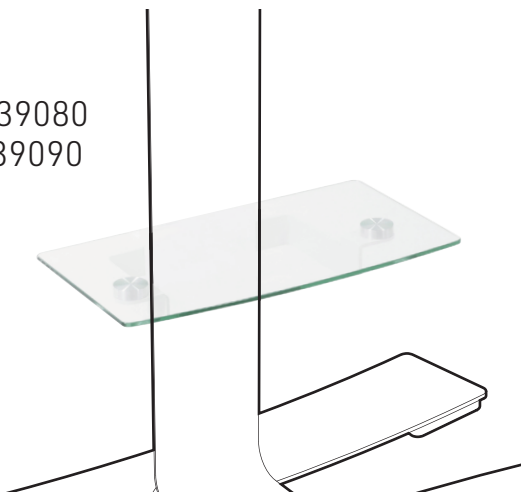

ref. 038401

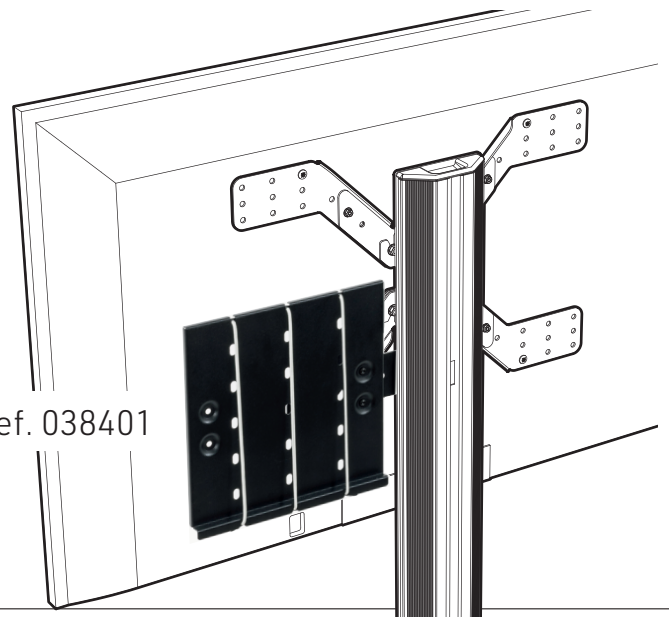

- F** **Recommandations d'entretien**  
N'utiliser que de l'eau ou un produit nettoyant pour les vitres. Ne jamais utiliser un produit de nettoyage contenant de l'acétone, de l'essence ou de l'alcool ainsi que du White Spirit ou du diluant synthétique qui endommageraient le meuble.
- GB** **Cleaning instructions**  
Only use water or window cleaning product. Do not use cleaning solvent with acetone, oil, white spirit or synthetic thinner as these will damage the tv stand.
- D** **Pflege- anleitungen**  
Benutzen nur Wasser oder Glasreinigungsmittel. Benutzen Sie keine azetonhaltigen, essenzhaltigen, alkoholhaltigen Reinigungsmitteln, Terpentinersatz oder synthetischen Auflösungsmitteln da sie das Möbel beschädigen könnten.

- E** **Instrucciones de Limpieza**  
Utilizar solamente agua o producto para cristal. No utilizar productos a base de alcohol, acetona, esencia, aguarrás o sintético diluyente soluciones que dañarían el mueble.
- I** **Raccomandazione di manutenzione**  
Usa che l'acqua o un prodotto pulito per le vetri. Non mai utilizzare un prodotto di pulito contenenti dell'acetone, della benzina o dell'alcool o sole del Bianco spirito o del diluente Sintetiche.
- NL** **Reinigings- instructies**  
Gebruik alleen een ruitenreiniger of water. Gebruik nooit producten op basis van aceton, benzine, terpentijn of andere synthetische verdunningsmiddelen, daar deze producten het meubel kunnen beschadigen.

# KIT TV ADAPT<sup>+</sup>

KIT D'ADAPTATION POUR ÉCRANS À DOS COURBES OU IRRÉGULIERS  
 ADAPTATION KIT FOR SCREENS WITH A CURVED OR UNEVEN BACK SIDE  
 EINBAUSATZ FÜR CURVED-TVS UND BILDSCHIRME MIT UNEBENER RÜCKSEITE



Permet d'adapter tous les supports pour écrans, aux écrans incurvés ou plats à dos irréguliers. Kit compatible avec les principales marques d'écrans (SAMSUNG, SONY, PHILIPS, LG...).

Allows fitting of all TV mounts to curved TVs and TVs with uneven back side. Kit compatible with the most common TV brands (SAMSUNG, SONY, PHILIPS, LG...).

Macht Curved-TVs und Bildschirme mit unebener Rückseite mit allen Flachbildschirm Halterungen kompatibel. Adapter-Kit für die meisten Fernseher-Modelle (Samsung, Sony, Philips, LG, ...).

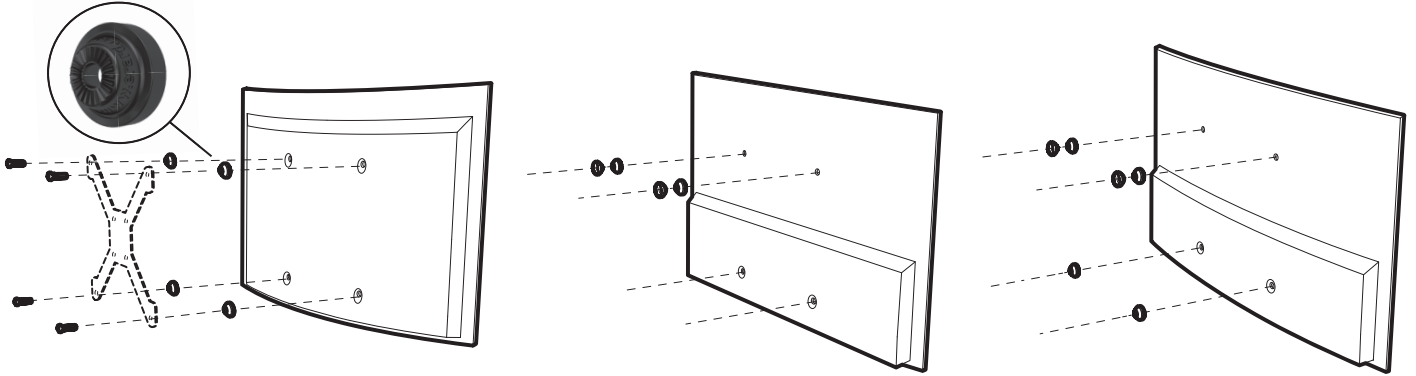

1

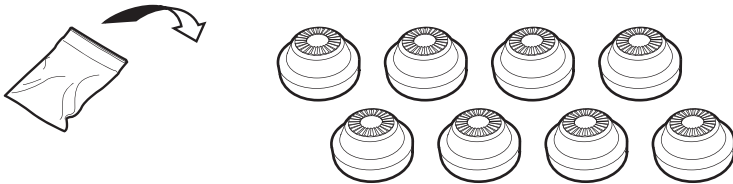

2

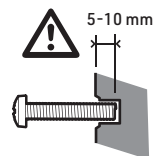
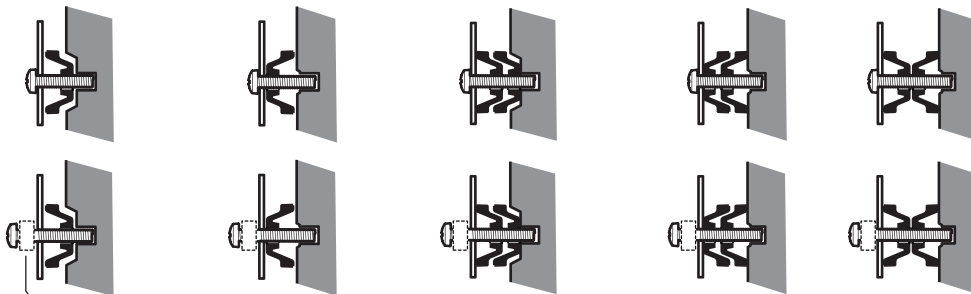
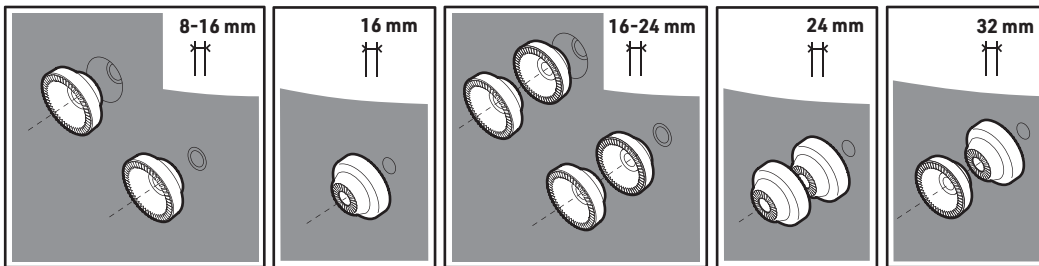
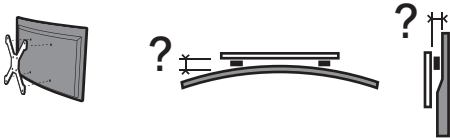

## F Garantie

Pour une bonne installation et prise en main de votre produit, nous vous recommandons de lire attentivement le présent manuel avant montage et utilisation.

### Conditions de garantie

Votre produit ERARD a été soumis à tous les essais requis et remplit toutes les exigences de sécurité applicables. Si toutefois des défauts de fabrication ou de matériaux devaient apparaître, ERARD prendrait en charge l'échange de la pièce défectueuse ou du produit pendant 10 ans ou uniquement pendant 2 ans s'il s'agit d'un défaut sur les modules motorisés et électroniques ou sur les produits à base de bois laqué.

Les modalités d'exercice de la présente garantie sont précisées dans les conditions générales de vente ERARD. Pour bénéficier de cette garantie, vous devez contacter le service consommateur au numéro suivant : +33 (0)4 72 46 16 26 et leur transmettre une copie de la facture originale précisant la date d'achat, le nom du revendeur ainsi que ce bon de garantie indiquant le type de produit et son numéro de série.

Toutefois, la garantie ne couvre pas les cas suivants :

- Dommages dus à une cause extérieure à l'appareil notamment foudre, chute du produit, dégât des eaux, incendie, etc.
- Usure normale du matériel.
- Frais d'acheminement ainsi que tout dommage durant le transport, liés à l'exécution de cette garantie.
- Dommages causés par négligence, détériorations dues au stockage, installation défectueuse, utilisations anormales, contraire ou non conforme aux recommandations de ce manuel, modifications, réparations effectuées par des personnes non mandatées par ERARD, etc.

### AVERTISSEMENT

Pour les supports ERARD, les vis et les chevilles fournies sont prévues pour des murs en matériaux durs et pleins (béton, brique pleine...). Pour les autres matériaux, utiliser des systèmes de fixation adaptés à la qualité du mur et au poids à supporter.

### Recyclage en fin de vie

Pour contribuer à la protection de l'environnement, utiliser les méthodes d'élimination et de récupération des emballages appropriées. Les cartons utilisés pour l'emballage de ce produit peuvent être recyclés ou réutilisés.

## D Garantie

Zur einwandfreien Installation und Inbetriebnahme Ihres Produktes empfehlen wir Ihnen, die vorliegende Gebrauchsanleitung vor der Montage und Bedienung aufmerksam durchzulesen.

### Garantiebedingungen

Dieses ERARD Produkt wurde allen erforderlichen Tests unterzogen und erfüllt alle einschlägigen Sicherheitsforderungen. Sollten innerhalb eines Zeitraums von 10 Jahren Herstellungs- oder Materialmängel auftreten, übernimmt ERARD die Reparatur des Produkts (Teile und Lohn) oder, wenn das Produkt nicht repariert werden kann, erfolgt der Austausch des Produkts oder des schadhafte Teils. Bei den motorisierten und elektronischen Modulen bzw. bei den Produkten aus lackiertem Holz ist dieser Garantiezeitraum auf 2 Jahre beschränkt.

Die Modalitäten zur Inanspruchnahme dieser Garantie sind in den Allgemeinen Verkaufsbedingungen von ERARD festgelegt.

Um diese Garantie geltend zu machen, wenden Sie sich bitte an unseren Kundenservice (Anruf innerhalb Frankreichs kostenlos unter der: +33 (0)4 72 46 16 26) und schicken ihm eine Kopie der Originalrechnung mit dem Kaufdatum und dem Namen des Händlers sowie die Garantiekarte mit der Angabe des Produkttyps und der Seriennummer.

Die folgenden Fälle sind von der Garantie jedoch nicht abgedeckt:

- Schäden aufgrund äußerer Ursachen, insbesondere Blitzschlag, Herunterfallen des Produkts, Wasserschäden, Brand usw.
- Normale Abnutzungserscheinungen des Produkts.
- Transportkosten sowie alle Transportschäden in Zusammenhang mit der Ausführung der Garantie.
- Schäden durch Nachlässigkeit, Lagerungsschäden, falsches Installieren, unsachgemäßen Gebrauch, Gebrauch im Widerspruch mit oder abweichend von den Empfehlungen dieses Handbuchs, Reparaturen durch nicht von ERARD befugte Personen usw.

### WARNUNG:

Die mitgelieferten Schrauben und Dübel sind für Mauern aus harten und vollen Materialien vorgesehen (Beton, voller Ziegelstein...). Für die anderen Materialien Befestigungssysteme benutzen, die der Qualität der Mauer und an das zu tragende Gewicht angepasst sind.

### Recycling am Lebensende

Aus Gründen des Umweltschutzes beachten Sie beim Entsorgen der Verpackung stets die örtlichen Vorschriften und Recyclingmöglichkeiten. Die für die Verpackung dieses Produkts verwendeten Kartons können dem Recycling zugeführt und weiter verwertet werden.

## GB Guarantee

In order to ensure correct installation and familiarity with this product, we recommend you read this manual carefully before assembly and use.

### Terms of guarantee

Your ERARD product has been subject to quality control and meets all of the applicable safety standards. Nonetheless, should any manufacture or material faults become apparent, ERARD undertakes to replace the defect part(s). If the product cannot be repaired, ERARD replaces it. This guarantee is valid for a period of 10 years, excluding motorized & electronic parts (2 years guarantee) and lacquered wooden parts (2 years guarantee). For detailed warranty procedure, please refer to ERARD terms and conditions of sale.

To benefit from this guarantee, please contact our customer service (toll-free number : +33 (0)4 72 46 16 26) and supply us with a copy of the original invoice showing the date of purchase and the name of the dealer, as well as the certificate of guarantee indicating the product type and the serial number.

The guarantee does not cover the following :

- Damage caused by an external cause, namely lightning, dropping the product, water damage, fire, etc.
- Replacement of consumable parts
- Transport expenses as well as any damage occurred during the transport, associated with the validity of this guarantee.
- Damage resulting from negligence, damage due to poor storage conditions, inappropriate installation, abnormal use, contrary to or nonconforming with the recommendations stipulated in this manual, repairs carried out by persons without the authorisation of ERARD, etc.

### WARNING:

Screws and plastic anchors provided with ERARD brackets are compatible with hard and full wall materials (concrete, solid brick...). For other materials, use fasteners adapted to the quality of the wall and the load to be supported.

### End-of-life recycling

To help to protect the environment, use the appropriate recycling and discarding methods for the packaging.

The boxes used for the packaging of this product may be recycled or re-used.

## ES Garantía

Para una buena instalación y uso de su producto, le recomendamos que lea detenidamente el presente manual antes del montaje y utilización.

### Condiciones de garantía

Su producto ERARD se ha sometido a todas las pruebas requeridas y ha cumplido todas las exigencias de seguridad aplicables. De todos modos, si llegasen a detectarse defectos de fabricación o materiales, ERARD se encargaría de cambiar el producto o la pieza defectuosa durante 10 años o sólo durante 2 años si se trata de un defecto en los módulos motorizados y electrónicos o en productos a base de madera lacada.

Las modalidades de ejercicio de la presente garantía se especifican en las condiciones generales de venta ERARD.

Para beneficiarse de esta garantía, debe ponerse en contacto con el servicio de atención al cliente (número gratuito: +33 (0)4 72 46 16 26) y enviarle una copia de la factura original en la que conste la fecha de compra y el nombre del vendedor así como la ficha de garantía que indique el tipo de producto y su número de serie.

La garantía no cubre los casos siguientes :

- Daños producidos por una causa ajena al aparato sobre todo rayos, caída del producto, inundación, incendio, etc.
- Desgaste normal del material.
- Los gastos de envío así como cualquier año sufrido durante el transporte, vinculados a la ejecución de esta garantía.
- Daños causados por negligencia, deterioros producidos por el almacenamiento, instalación defectuosa, utilizaciones anormales, contrarias o que no cumplan las recomendaciones de este manual, modificaciones, reparaciones efectuadas por personas no autorizadas por ERARD, etc.

### ADVERTENCIA:

Los tornillos y las clavijas proporcionados con los soportes ERARD están diseñados para paredes de materiales duros y macizos (hormigón, ladrillo macizo...). Para otros materiales, utilice sistemas de fijación adaptados a la calidad de la pared y a la carga que soportarán.

### Reciclaje al final de su vida útil

Para contribuir a la protección del medio ambiente, utilice los métodos de eliminación y de reciclaje apropiados para los embalajes.

Las cajas utilizadas para el embalaje de este producto pueden reciclarse o reutilizarse.

# I Garanzia

Per una buona installazione ed un buon avvio del prodotto, si consiglia di leggere attentamente il presente manuale, prima del montaggio e dell'utilizzo.

## Condizioni di garanzia

Il prodotto ERARD è stato soggetto a tutti i collaudi richiesti e soddisfa tutte le esigenze di sicurezza applicabili. Se tuttavia dovessero apparire difetti di fabbricazione o di materiali, ERARD si farà carico della sostituzione del pezzo difettoso o del prodotto per 10 anni e soltanto per 2 anni se si tratta di un difetto dei moduli motorizzati ed elettronici o dei prodotti a base di legno laccato.

Le modalità di esercizio della presente garanzia sono precisate nelle condizioni generali di vendita ERARD.

Per usufruire di questa garanzia, occorre contattare il servizio consumatori (numero verde: +33 (0)4 72 46 16 26) ed inoltrargli una copia della fattura originale precisando la data di acquisto, il nome del rivenditore nonché il buono di garanzia indicante il tipo di prodotto e il relativo numero di serie.

Tuttavia, la garanzia non copre i seguenti casi:

- Danni dovuti ad una causa esterna all'apparecchio, nella fattispecie, fulmine, caduta del prodotto, danni da acqua, incendio, ecc.
- Usura normale del materiale.
- Spese di inoltro e qualunque danno durante il trasporto, correlati con l'esecuzione di questa garanzia.
- Danni causati da negligenza, deterioramenti dovuti all'immagazzinaggio, all'installazione difettosa, ad utilizzo anomalo, contrario o non conforme alle raccomandazioni del presente manuale, modifiche, riparazioni effettuate da persone non autorizzate da ERARD, ecc.

## AVVERTENZA:

Per i supporti ERARD, le viti e i tasselli in dotazione sono adatti a muri in materiali duri e pieni (cemento, mattoni pieni...). Per gli altri materiali, utilizzare sistemi di fissaggio adeguati alla qualità della parete e al peso da sostenere.

## Riciclaggio a fine vita

Per contribuire alla salvaguardia dell'ambiente, procedere con metodi adeguati di smaltimento e di recupero degli imballaggi. I cartoni usati per l'imballaggio di questo prodotto possono essere riciclati o riutilizzati.

# NL Garantie

Voor een goede installatie en ingebruikname van uw product, raden wij u aan, voor montage en gebruik, deze handleiding aandachtig te lezen.

## Garantievoorwaarden

Uw product van ERARD is onderworpen aan alle vereiste proeven en voldoet aan alle geldende veiligheidsvereisten. Indien toch fabricage- of materiaalfouten zouden optreden, zal ERARD het defecte onderdeel of het product vervangen tot 10 jaar na aankoop. Deze periode bedraagt slechts 2 jaar indien het een defect van de gemotoriseerde en elektronische modules of producten op basis van gelakt hout betreft.

De modaliteiten om deze garantie in te roepen, worden verduidelijkt in de algemene verkoopsvoorwaarden van ERARD.

Om van deze garantie gebruik te maken, dient u contact op te nemen met de klantendienst (gratis nummer: +33 (0)4 72 46 16 26) en een kopie van de originele factuur met datum van aankoop, de naam van de dealer en de garantiebon met het type en het serienummer van het product te bezorgen.

De garantie geldt evenwel niet in de volgende gevallen:

- schade als gevolg van een externe oorzaak, in het bijzonder bliksem, vallen, waterschade, brand, enz.
- normale slijtage van het materiaal,
- verzendingskosten en schade veroorzaakt tijdens het transport, in het kader van de uitvoering van deze garantie,
- schade veroorzaakt door nalatigheid, beschadigingen als gevolg van opslag, verkeerde installatie, abnormaal gebruik, in afwijking van of niet in overeenstemming met de aanbevelingen in deze handleiding, wijzigingen, reparaties uitgevoerd door personen die daartoe door ERARD niet gelast werden, enz.

## WAARSCHUWING:

De bij de dragers van ERARD geleverde schroeven en pluggen zijn bestemd voor volle muren van een hard materiaal (beton, volle baksteen, ...). Gelieve voor de andere materialen bevestigingssystemen te gebruiken die afgestemd zijn op de kwaliteit van de muur en het te dragen gewicht.

## Recyclage aan het einde van het levensduur

Om een bijdrage te leveren tot de bescherming van het milieu, gelieve de verpakkingen op de juiste manier te verwijderen en te recyclen. De dozen waarin het product verpakt wordt, kunnen gerecycleerd of hergebruikt worden.

# PT Garantia

Para garantir uma correcta instalação e uso adequado do seu produto, recomendamos que leia atentamente o presente manual antes de proceder à sua montagem e utilização.

## Condições da garantia

O seu produto ERARD foi submetido a todos os testes necessários, cumprindo com todos os requisitos de segurança aplicáveis. De qualquer modo, caso sejam visíveis defeitos de fabrico ou de materiais, a ERARD assume a substituição da peça defeituosa ou do produto durante 10 anos, excluindo partes ou componentes electrónicos ou motorizados (2 anos de garantia) e produtos com acabamentos lacados (2 anos de garantia).

As modalidades de exercício da presente garantia encontram-se descritas nas condições gerais de venda ERARD.

Para beneficiar desta garantia deve contactar o serviço de assistência ao cliente (número verde +33 (0)4 72 46 16 26) e apresentar cópia da factura original especificando a data de compra e o nome do revendedor bem como o certificado de garantia onde se indica o tipo de produto e respectivo número de série.

A garantia não abrange as seguintes situações:

- Danos provocados por motivos externos ao aparelho nomeadamente trovoadas, queda do produto, danos de água, incêndio, etc.
- Desgaste normal do material.
- Despesas de transporte, bem como qualquer dano ocorrido durante o transporte, relacionados com a validade da mesma garantia.
- Danos resultantes de negligência, deteriorações devido a condições de armazenamento, instalação incorrecta, utilizações invulgares, contrárias ou que não se encontrem em conformidade com as recomendações do presente manual, modificações, reparações efectuadas por pessoas não autorizadas pela ERARD, etc

## AVISO:

Os suportes ERARD, parafusos e buchas fornecidos destinam-se a paredes constituídas em materiais rígidos e planos (betão, tijolo liso...). Para os restantes materiais, utilizar sistemas de fixação adaptados à qualidade da parede e ao peso a suportar.

## Reciclagem em fim de vida

Para contribuir para a protecção do ambiente, utilizar métodos adequados de eliminação e recuperação das embalagens. As peças utilizadas para a embalagem deste produto podem ser recicladas.

[www.erard.com](http://www.erard.com)



Pensez à donner ou recycler.

Association  
ou

Magasin  
ou

Déchèterie

<https://quefairede mesdechets.fr>

Fabriqué en France  
Made in France

**ERARD**®  
[www.erard.com](http://www.erard.com)



**Vous avez des questions ?  
Vous avez besoin de conseils ?**

Tel : +33 (0)4 72 46 16 26

ERARD - ZI de Chavanoz, 4 route de la Plaine  
38230 CHAVANOZ - FRANCE

