



# EXOSTAND PRO

SUPPORT TV MURAL TOUT-EN-UN  
ALL-IN-ONE TV WALLMOUNT

Ref. 048461

**XL**



102-216 cm  
40-85"



35 kg  
77 lbs



355 mm  
14"



5 kg  
11 lbs

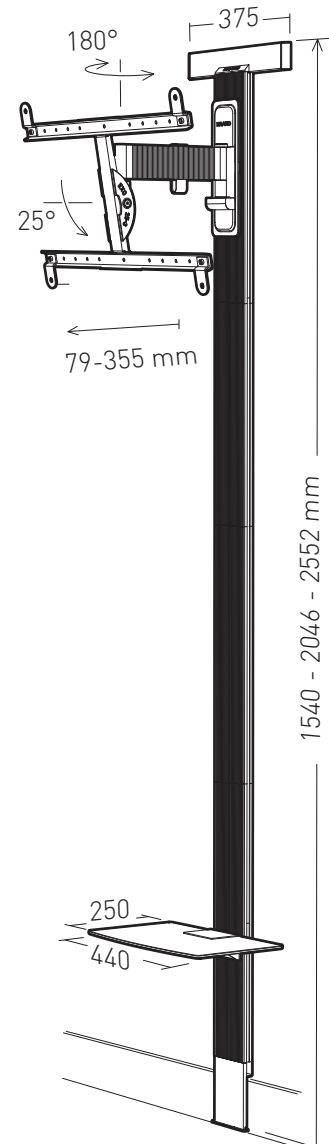
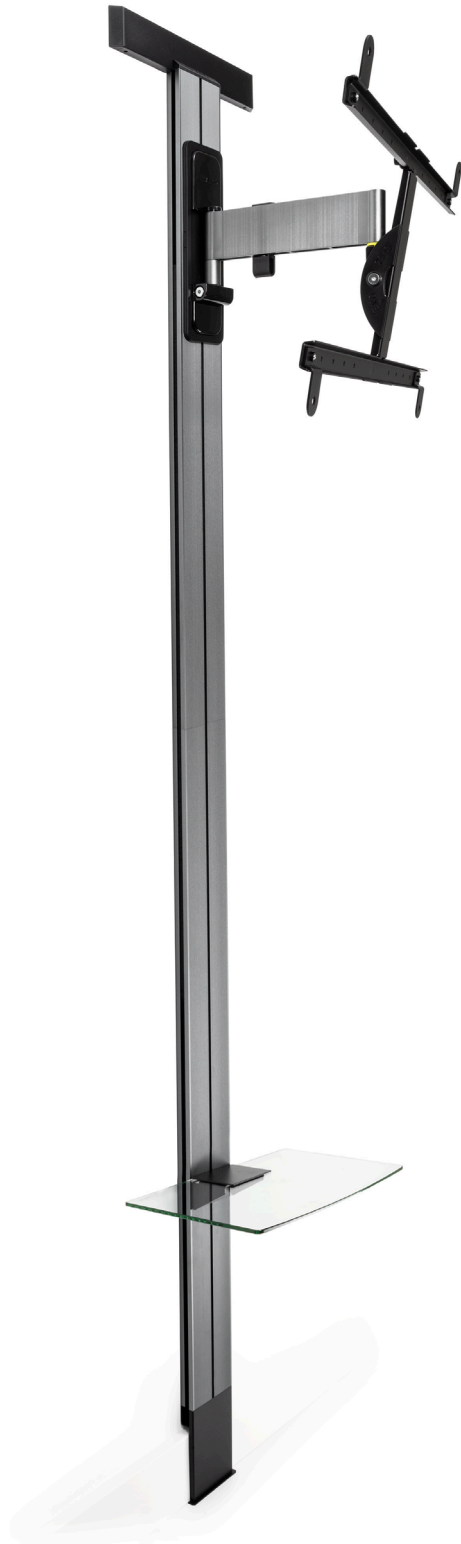

**ERARD®**

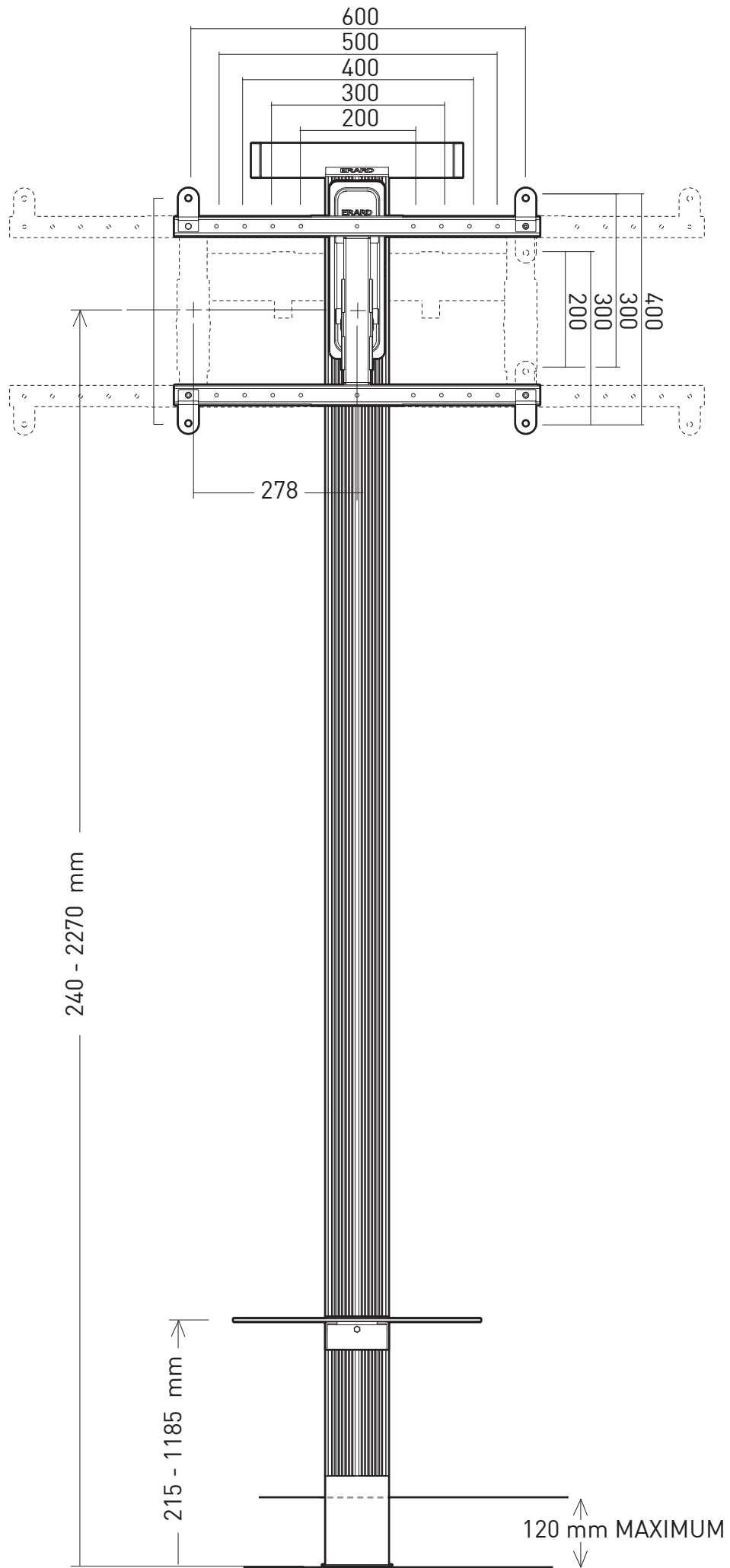

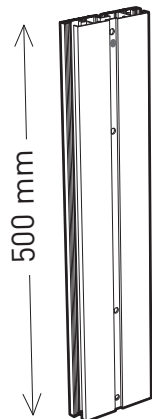

x2  
L2



x4  
M



x2  
P

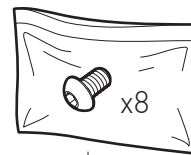

6

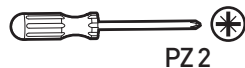
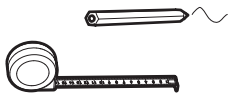
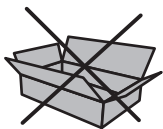

PZ2



N°13

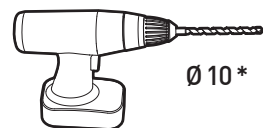

Ø 10\*

\* : p. 9, 12

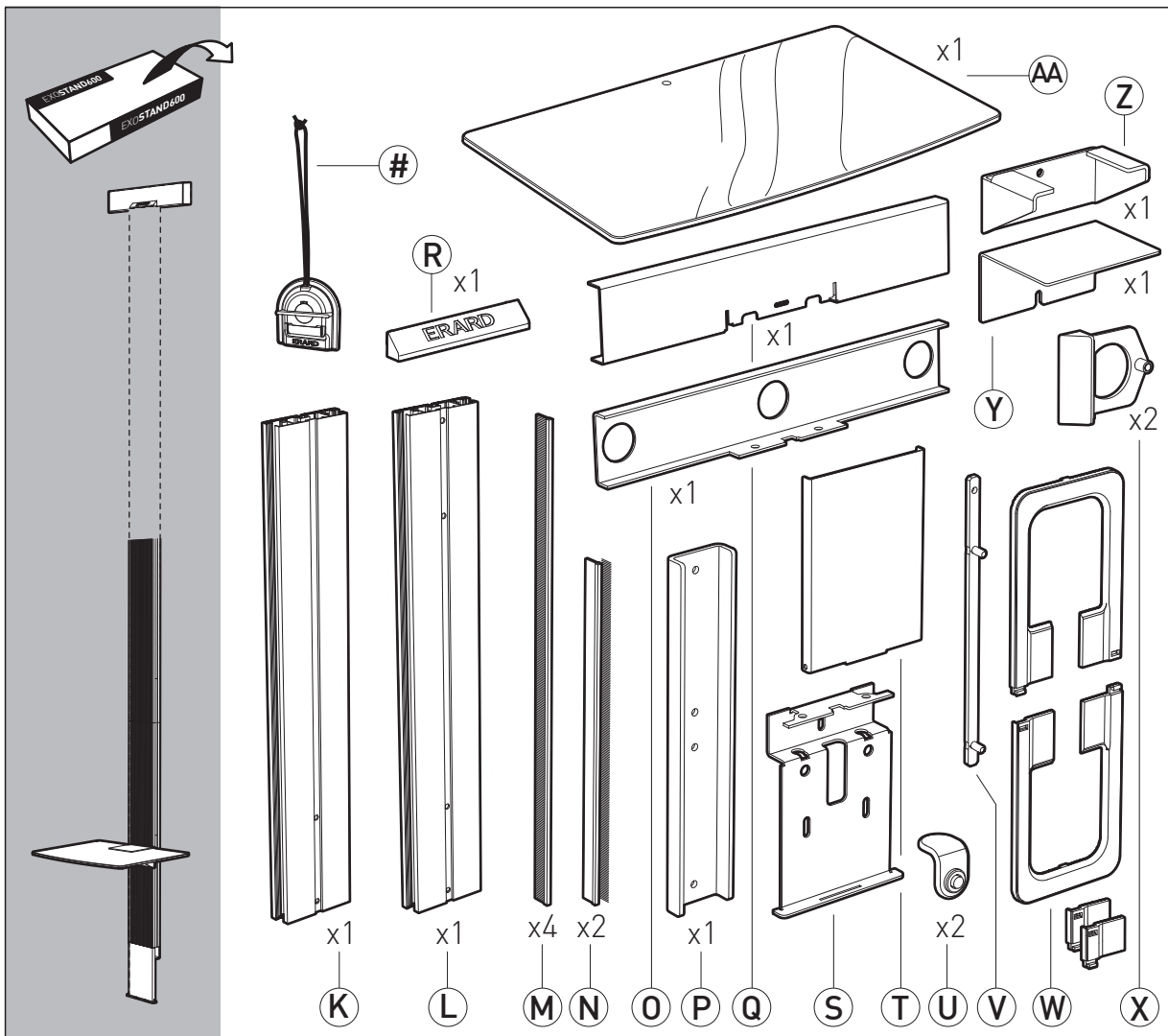
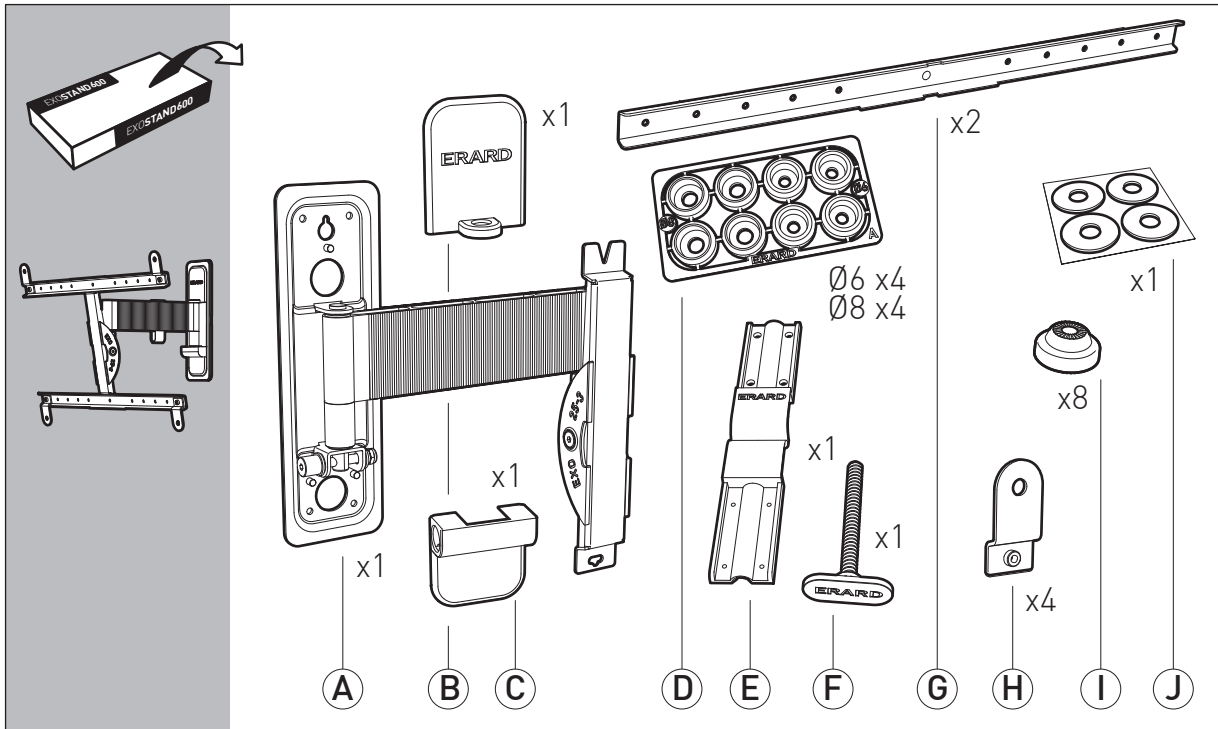
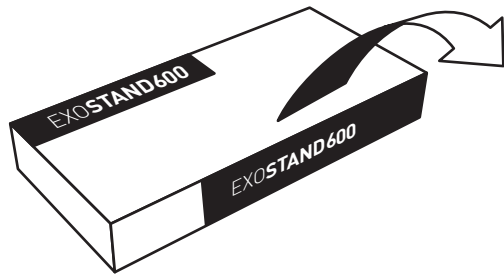

- 0 4x (Ø 6, 8)
- 1 Ø6
- 2 Ø8
- 3
- 4 N°5
- 5 N°4 x2
- 6 x4
- 7 x4
- 8 x2
- 9 x1
- 10 x2
- 11 x4
- 12 x2
- 13 x4
- 14 x4
- 15 x3
- 16 HM 5x37 x4
- 17 x3
- 18 x1
- T1 x1
- T2 x2

1  $6 \times 2 + K + P + 5$

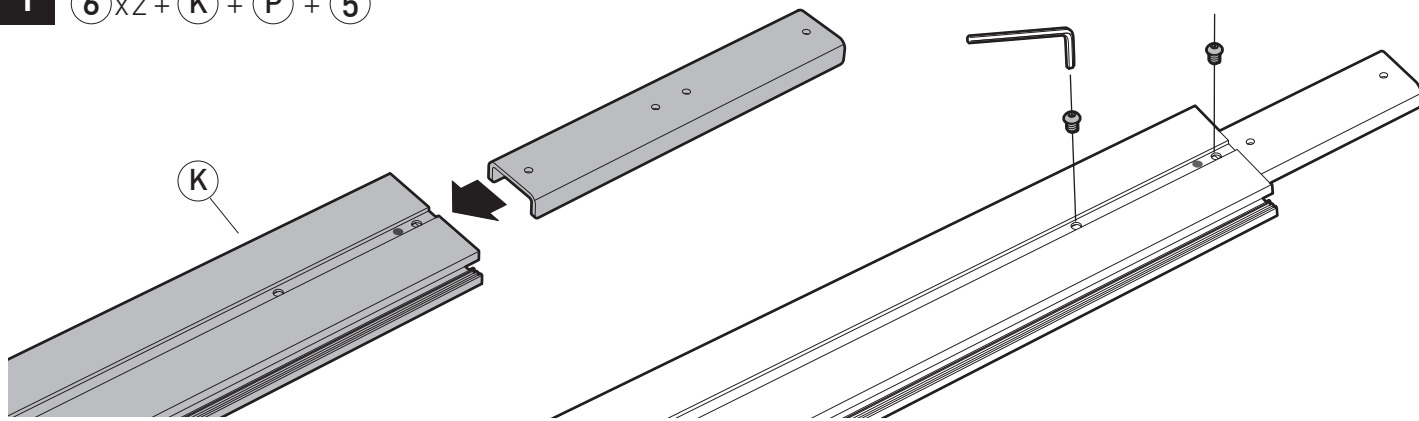

2  $6 \times 2 + L + 5$

1540 mm

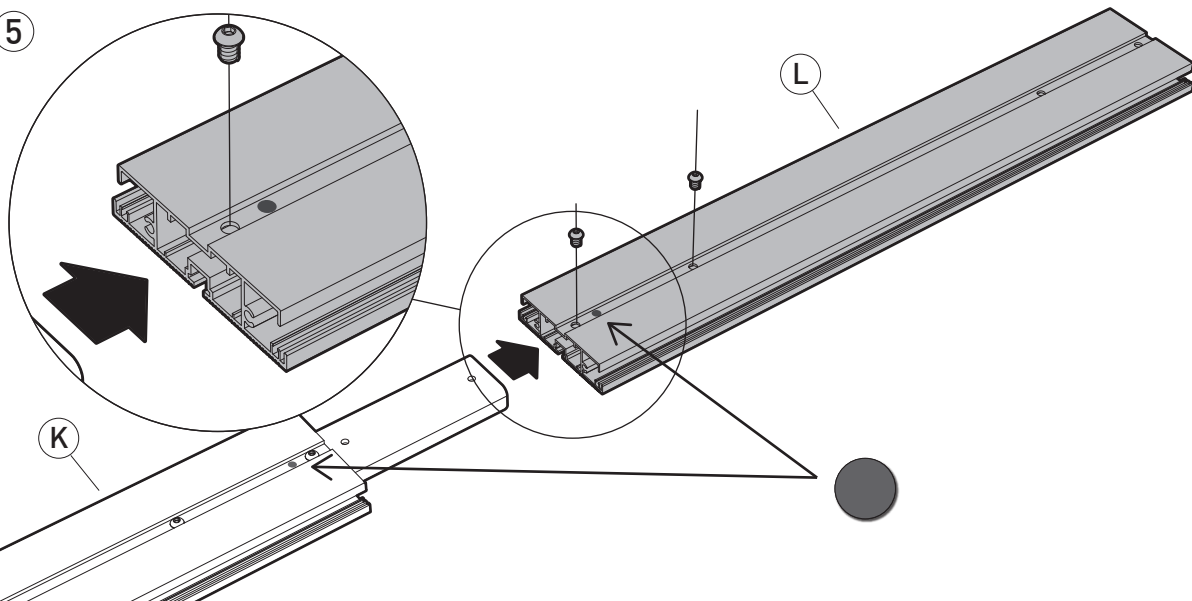

3  $6 \times 2 + L2 \times 1 + P \times 1 + 5$

2040 mm

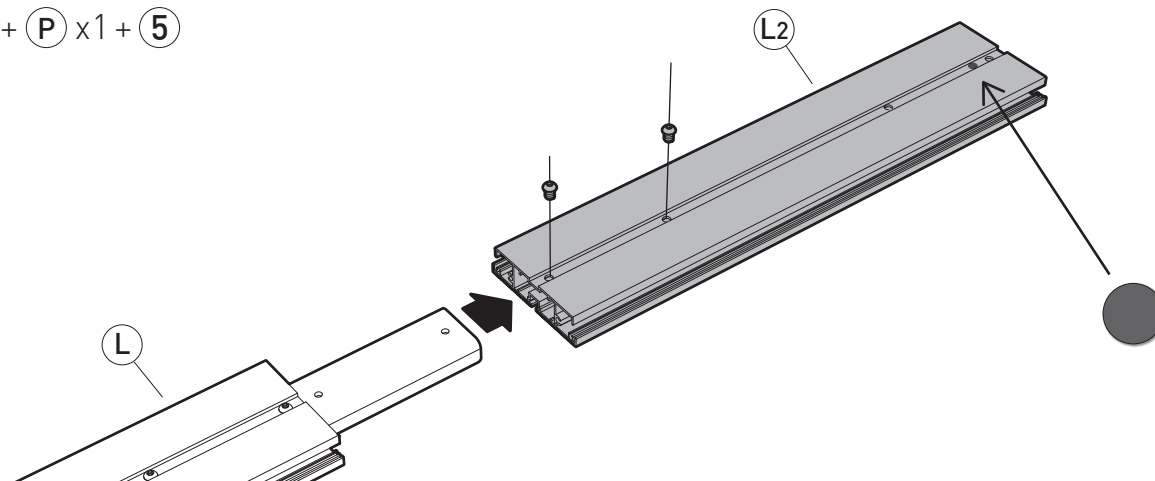

3 bis  $6 \times 2 + L2 \times 1 + P \times 1 + 5$

2540 mm

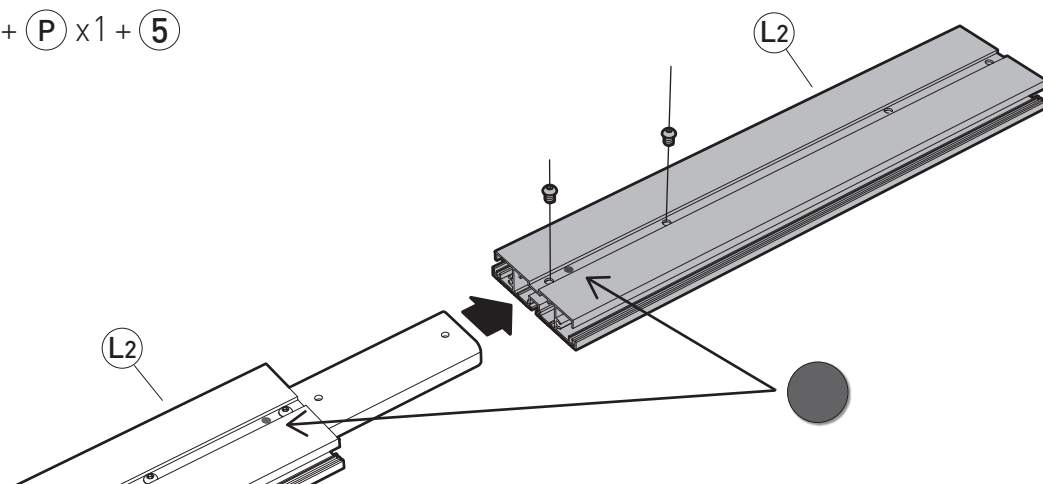

4 (M)x4 + (N)x2

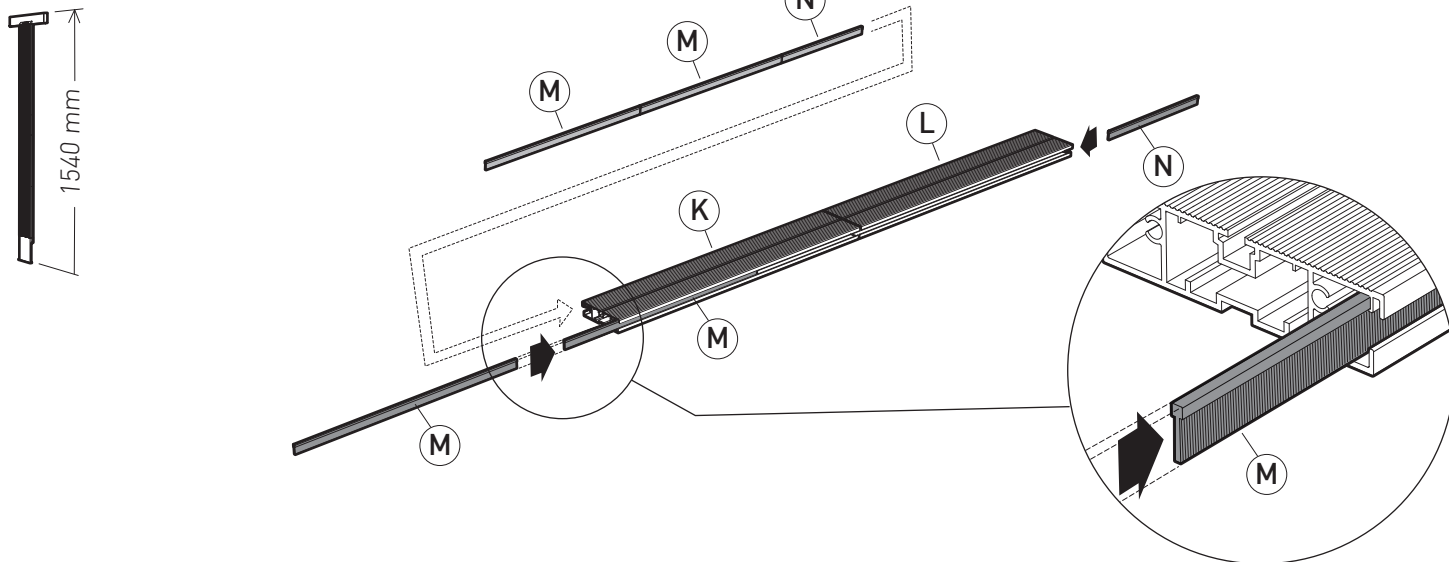

4<sup>bis</sup> (M)x6 + (N)x2

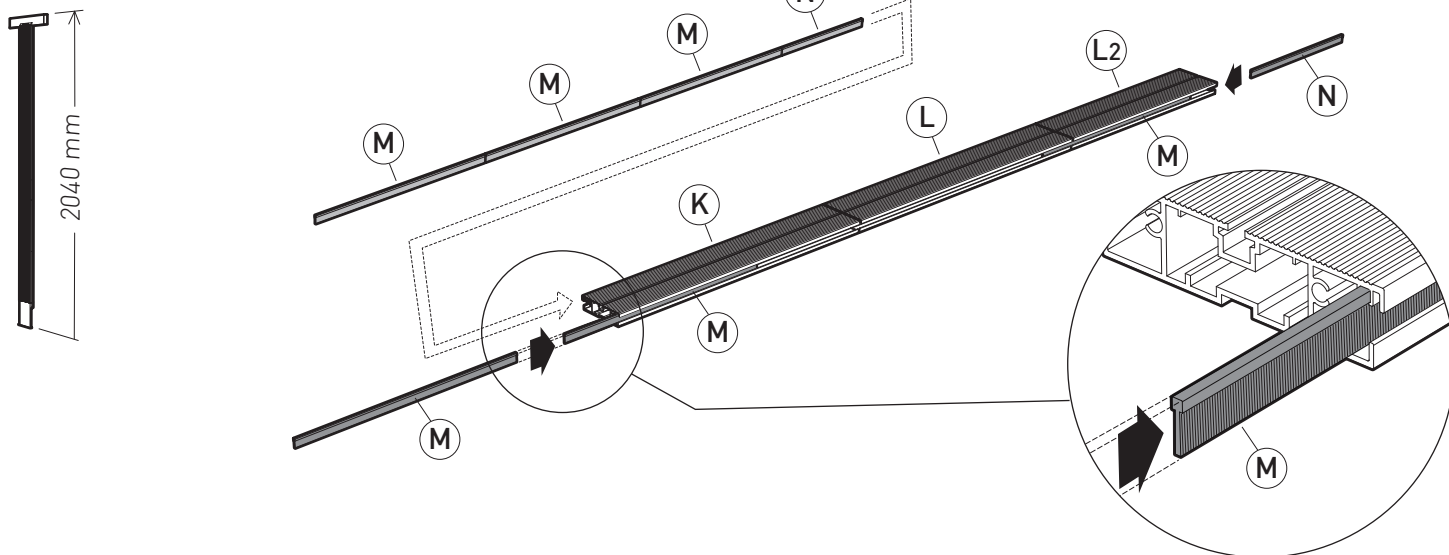

4<sup>ter</sup> (M)x8 + (N)x2

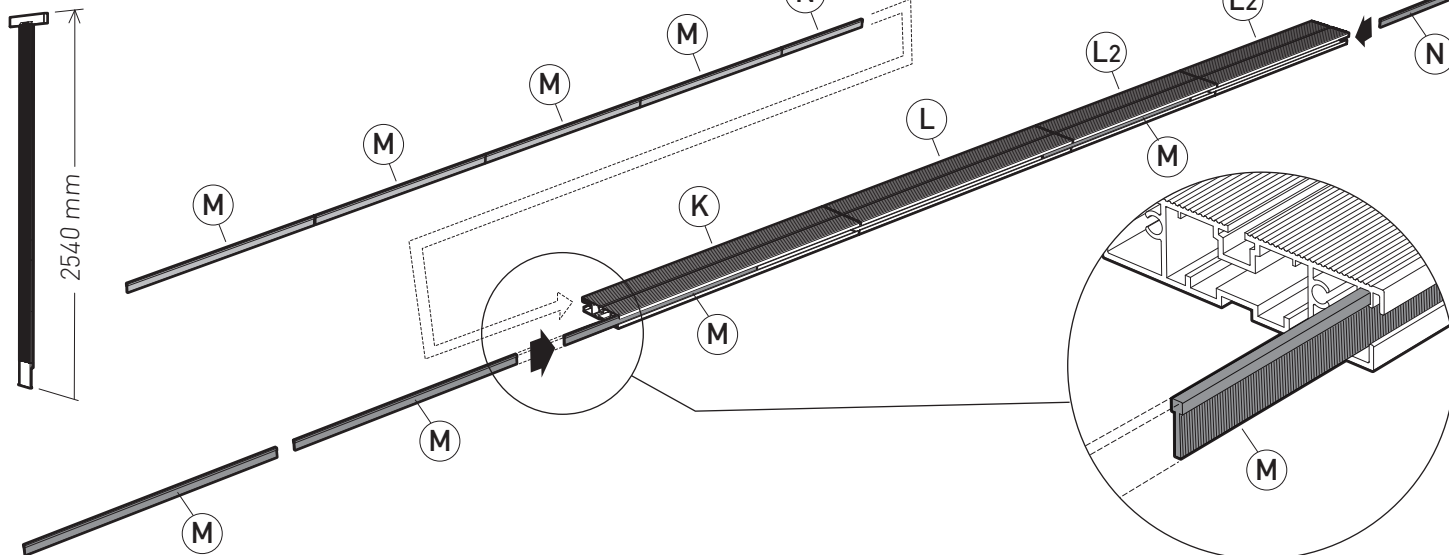

5 (S) + (7) x2 PZ2

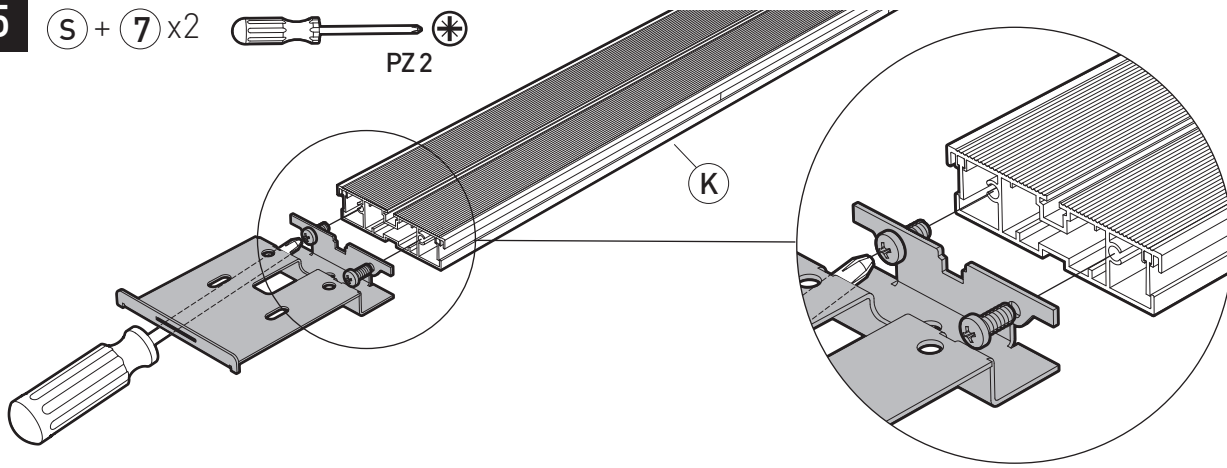

6 (O) + (7) x2 PZ2

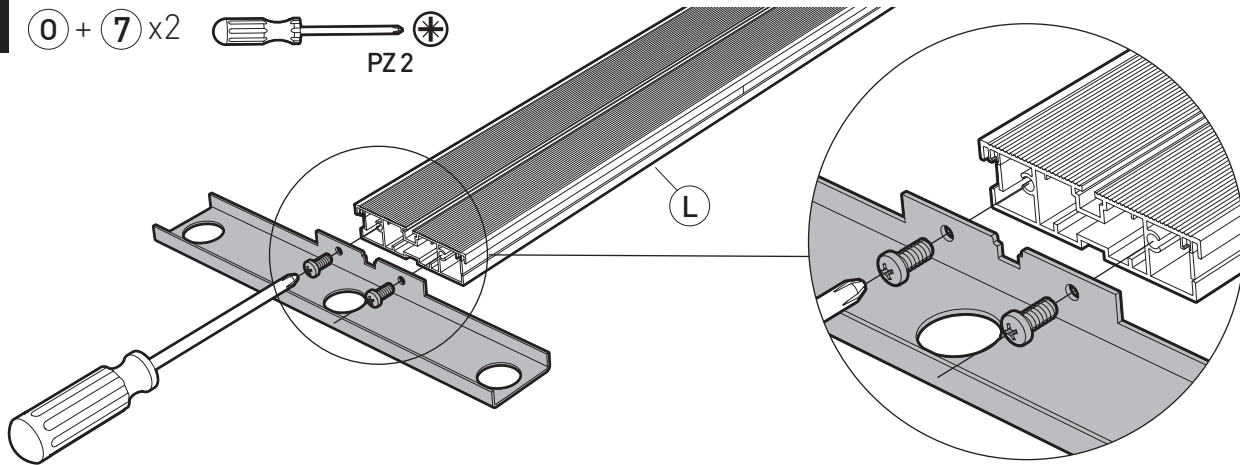

7 (V) + (9)

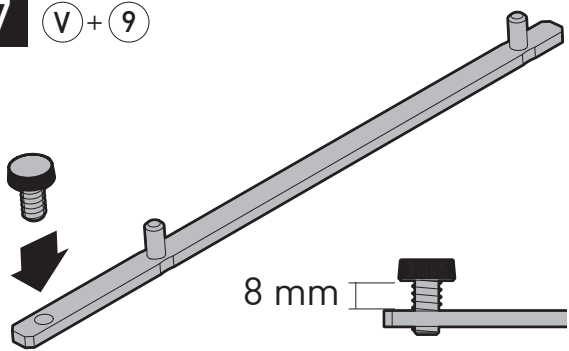

8 (V) + (9)

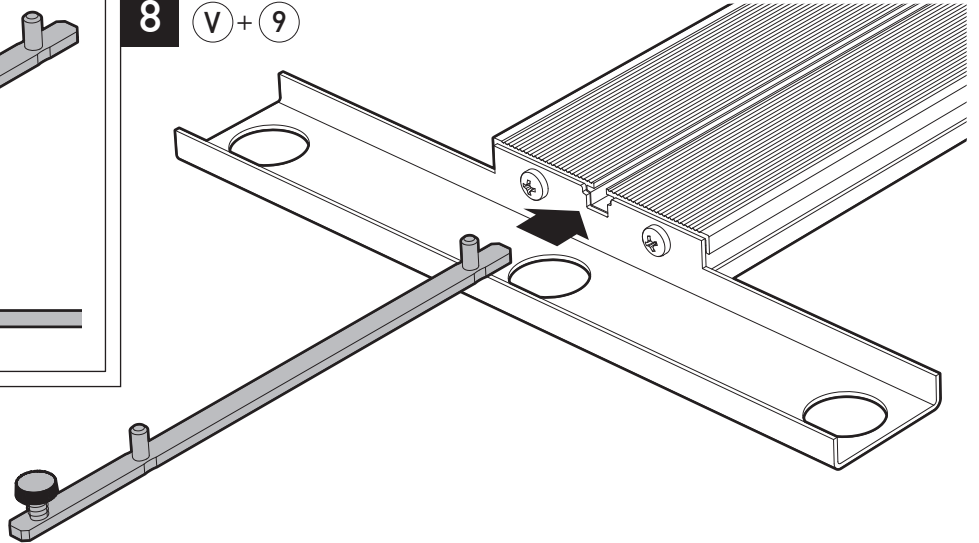

9 (W) x2

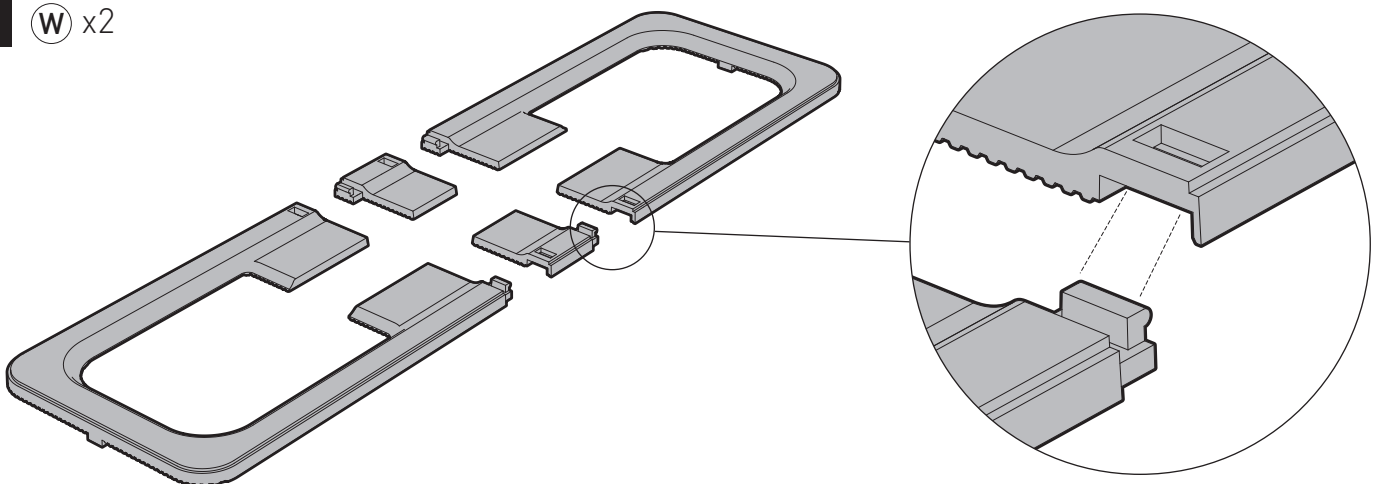

10 (A) + (W) x2

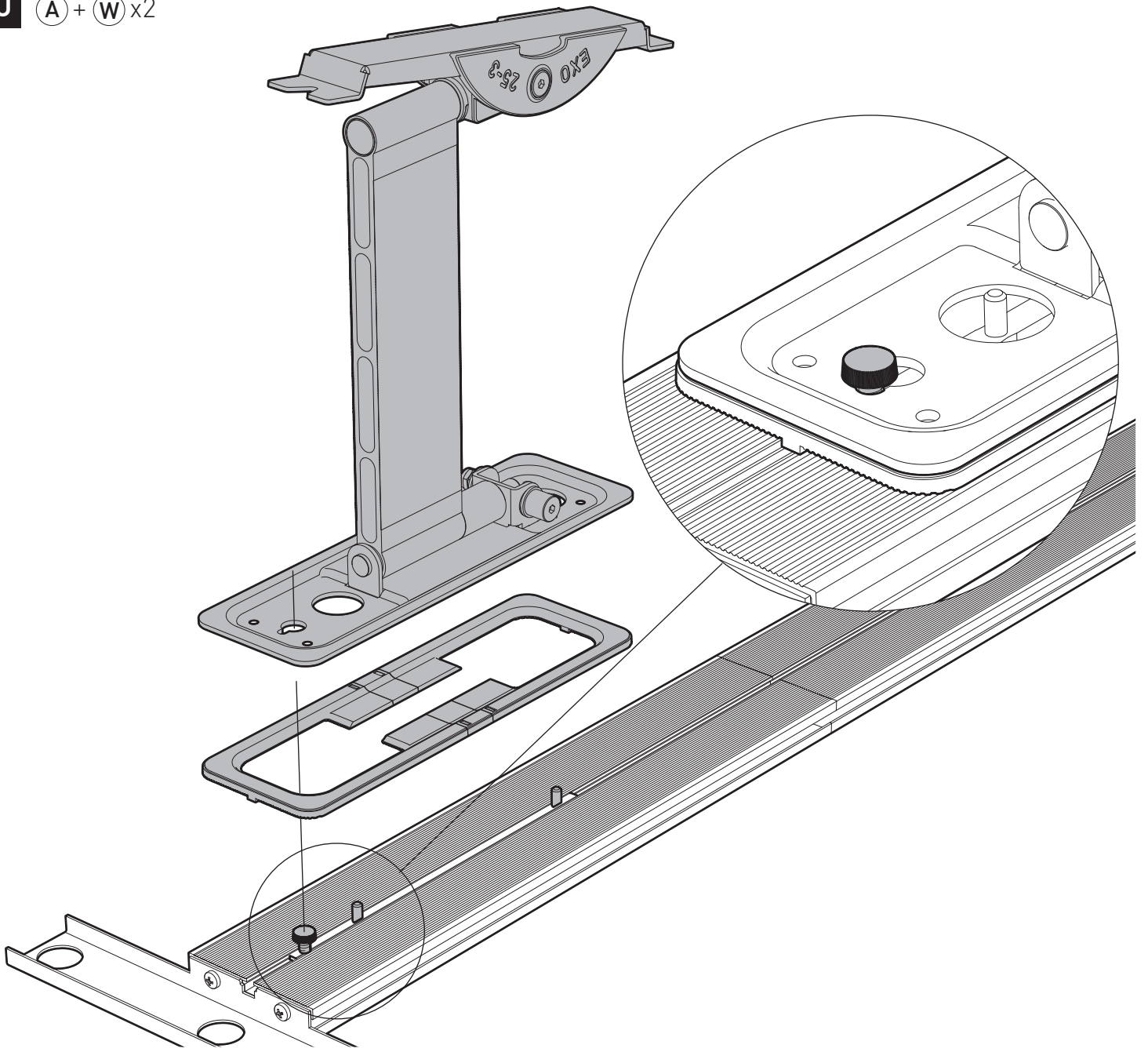

11 (8) x2 + (10) x2

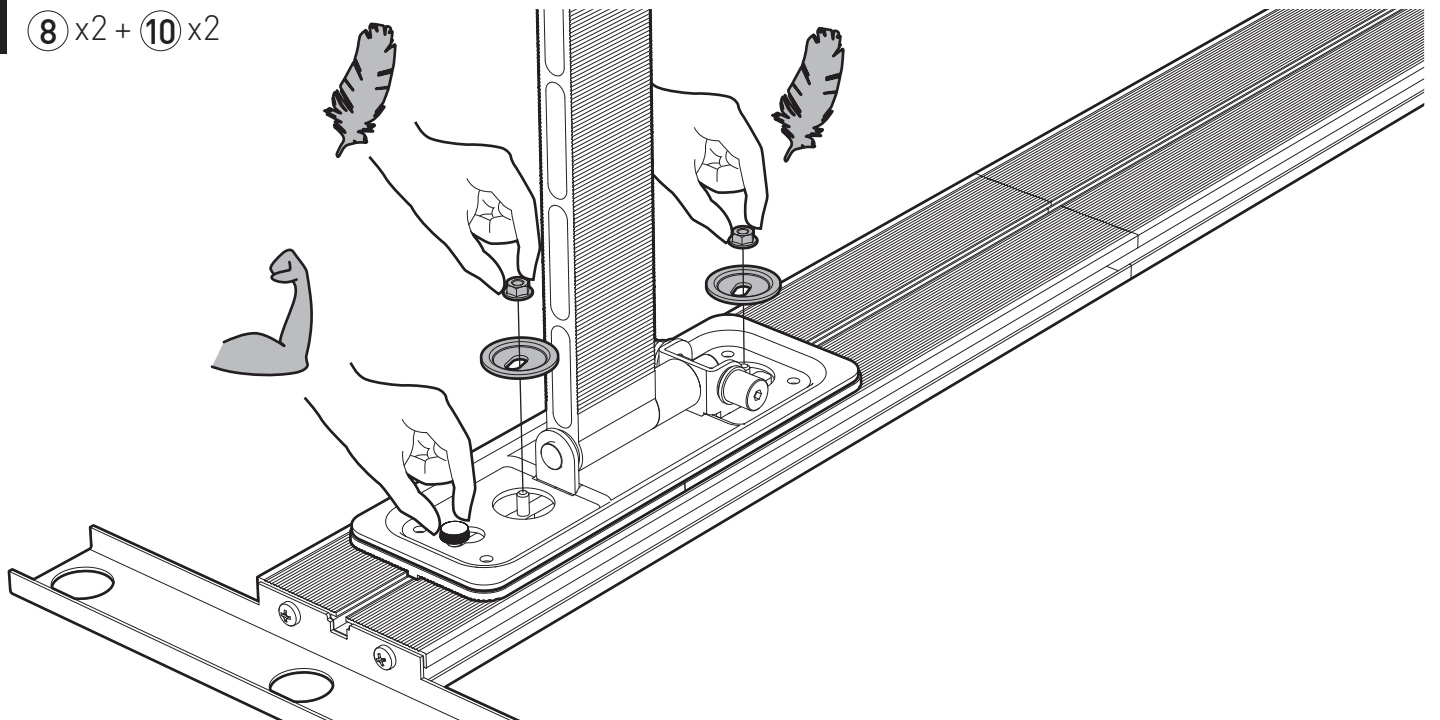

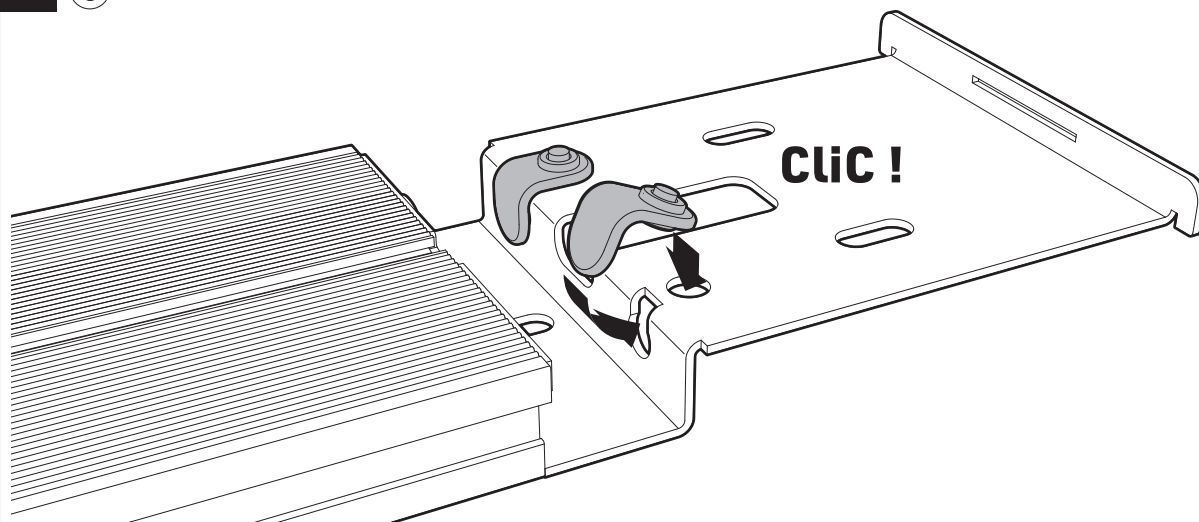

Matériaux durs : Béton, pierre...

Hard materials: concrete, stone, etc.

Harte Materialien: Beton, Stein,...

Materiales duros: Hormigón, piedra

Materiali duri: cemento, pietra, ecc.

Harde materialen: Beton, steen ...

Materiais rígidos: betão, pedra...

**A**

Panneaux bois

Wooden panels

Holzplatten

Paneles de madera

Pannelli in legno

Houten panelen

Painéis de madeira

**B**

BA 10  
BA 13

10 mm mini

Sur plaques de plâtre type BA10 épaisseur 10 mm minimum (norme EN 520+A1:2009). Murs sains : ni humidité, ni déchirures, ni fissurations. \* (P.21)

On type BA10 plasterboard, minimum thickness 10 mm (standard EN 520+A1:2009). Walls in a sound condition: no moisture, no tears, no cracks. \* (p. 21).

Auf Gipsplatten, Typ BA10, mindestens Dicke 10 mm (Norm EN 520+A1:2009). Umversehrte Wände: keine Feuchtigkeit, keine Spalten und keine Risse. \* (S. 21).

En el cartón-yeso tipo BA10 el espesor mínimo es de 10 mm (norma EN 520 +A1:2009). Paredes robustas: sin humedad, sin desgarros ni fisuras. \* (pág.21).

Su tramezzi in gesso di tipo BA10, di min. 10 mm di spessore (norma EN 520 +A1:2009). Muri integri, senza segni di umidità, squarci o fessurazioni. \* (P.21).

Op wanden uit gipsplaat type BA10 met een dikte van minimaal 10 mm (norm: EN 520 +A1:2009). Muren in perfecte staat: niet vochtig, geen openingen of scheuren. \* (P.21).

Em placas de gesso do tipo BA10: espessura mínima de 10 mm (Norma EN 520 +A1:2009). Paredes em perfeito estado: sem humidade, fendas nem fissuras. \* (P.21).

**C**



- **A** **B** **C**
- **A** **B** **C**
- **A** **B** **C**

A B C #

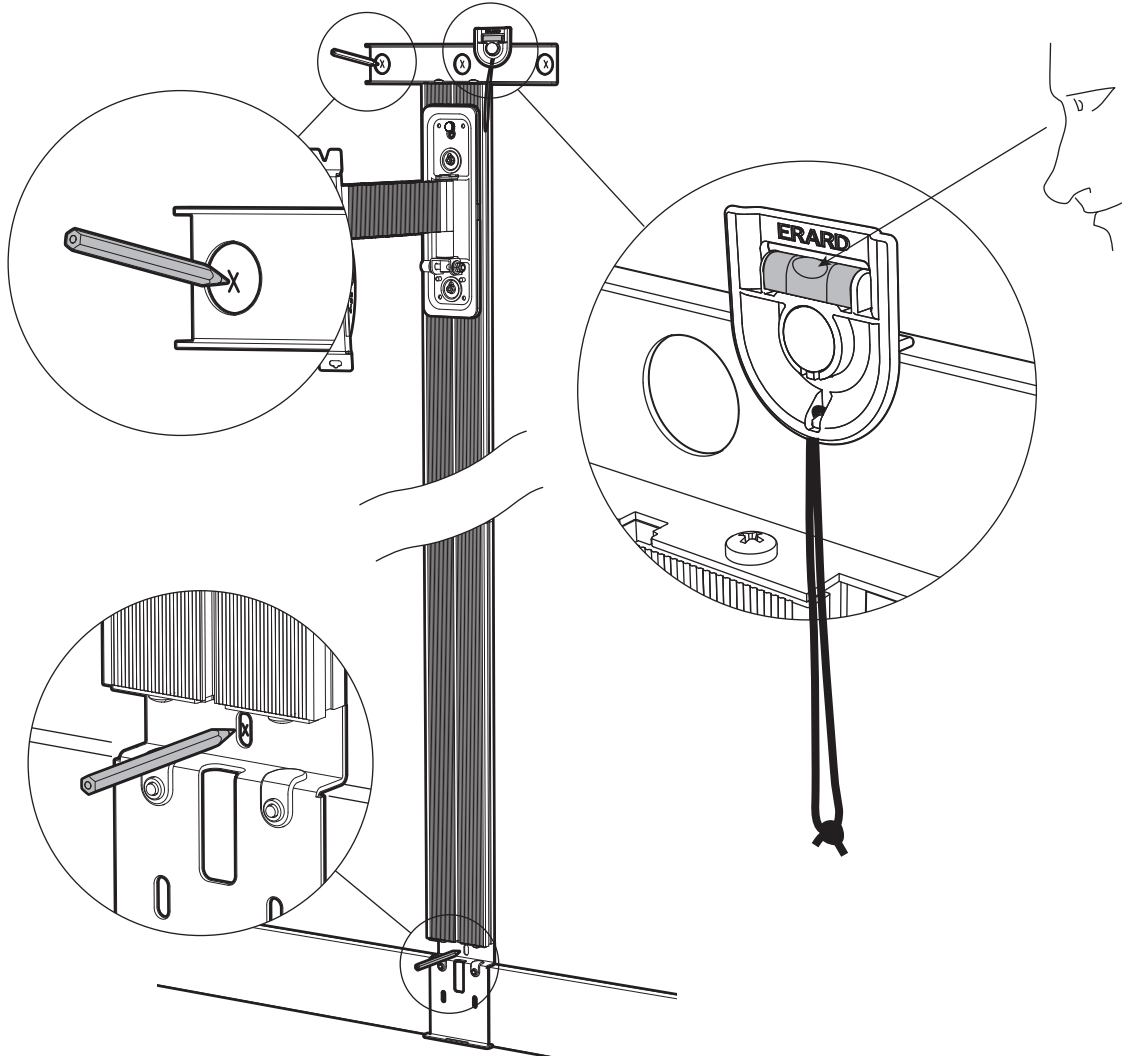
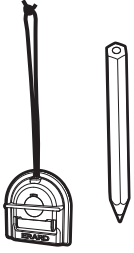

A B C

13 x4



\* Ø10

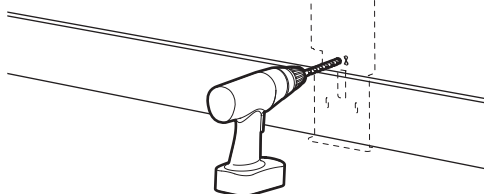
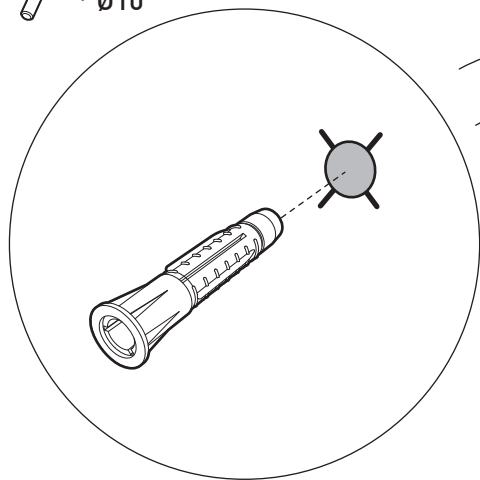
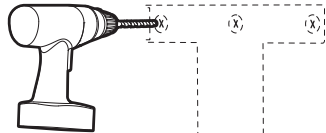

A B C

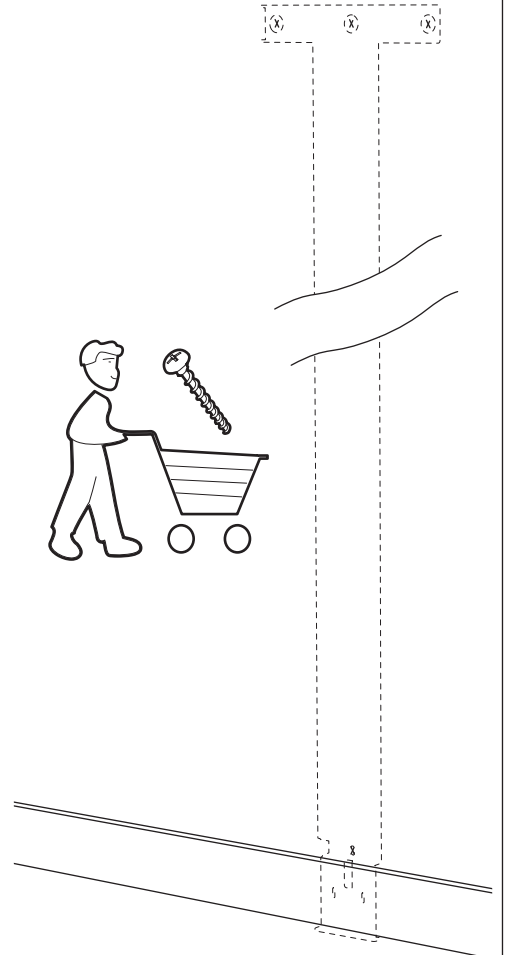

**A** **B** **C**

⑭ x4 + ⑮ x3

🔧 N°13

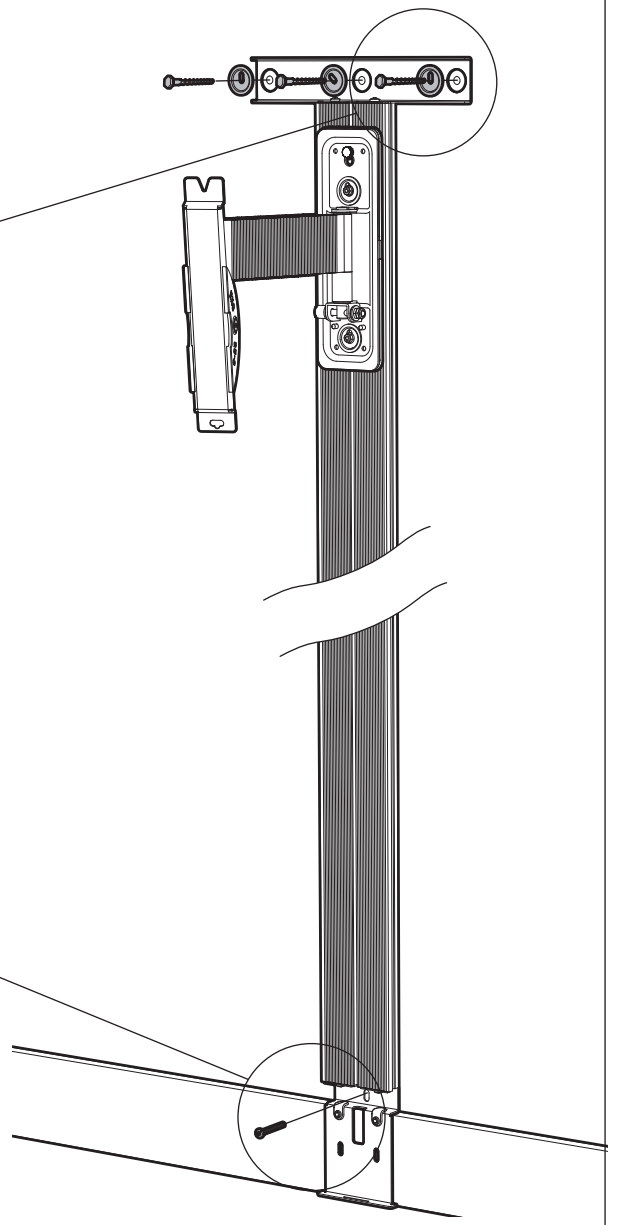
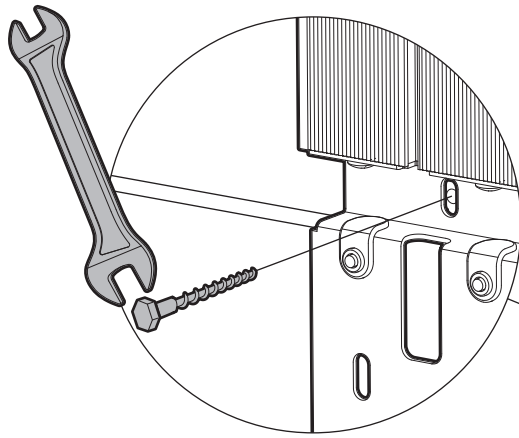
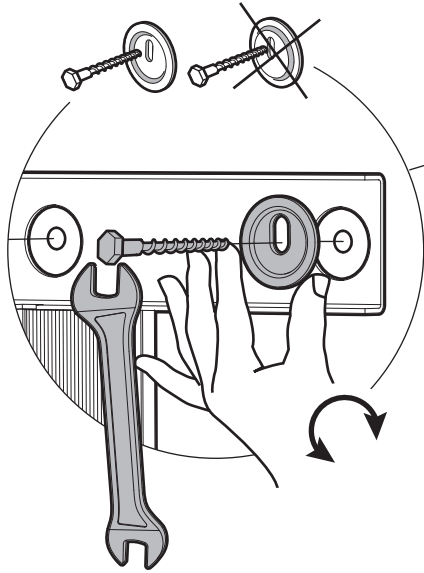

**A** **B** **C**

⑰ x3 + 🧑🛒 x4

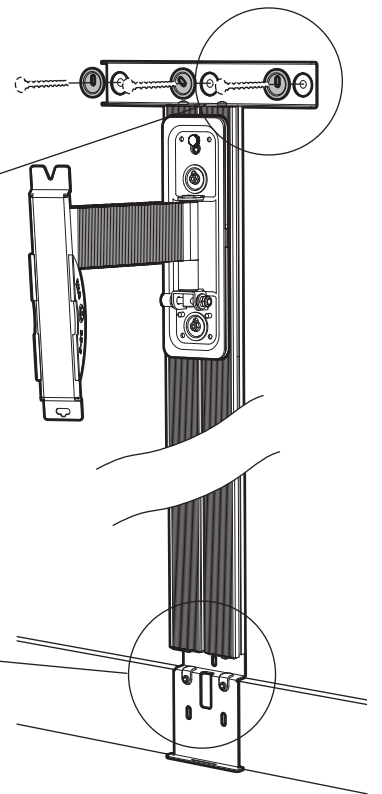
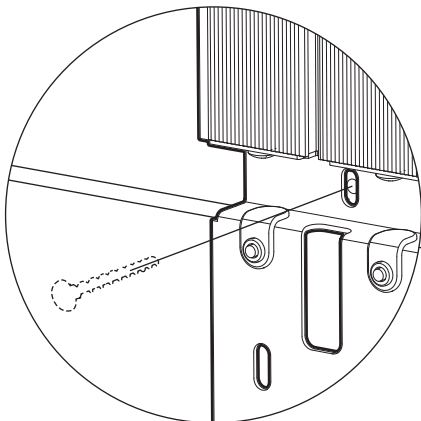
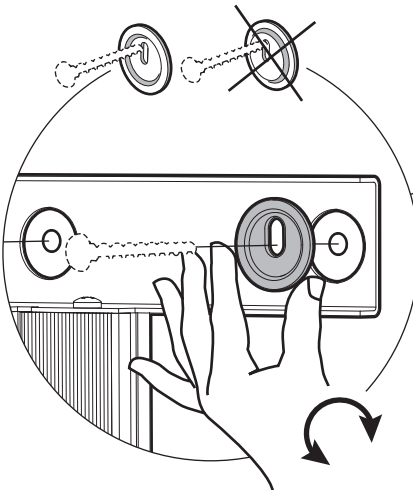

A B C #

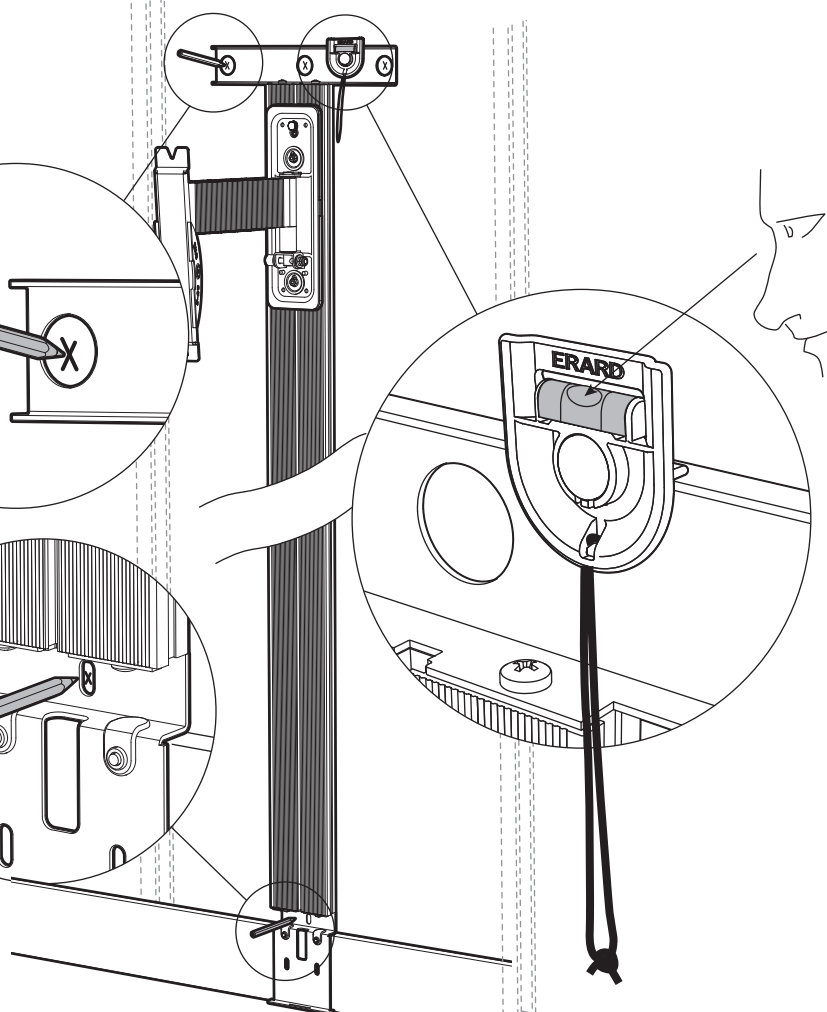
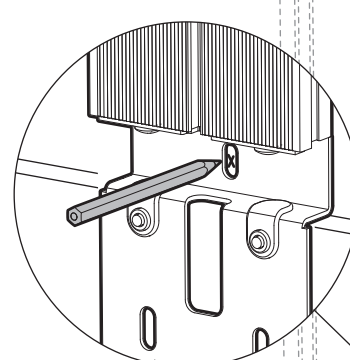
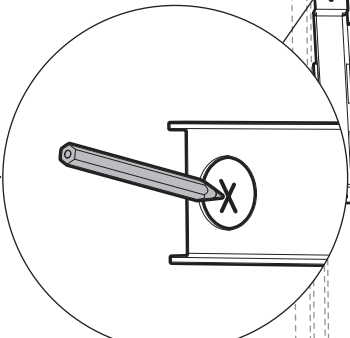
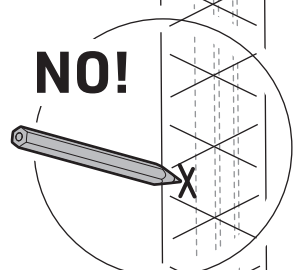
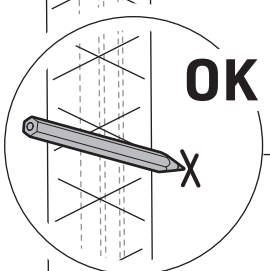
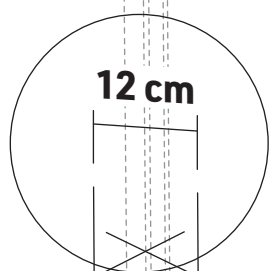
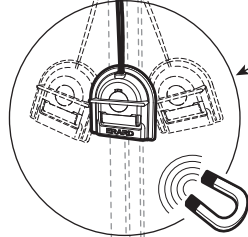
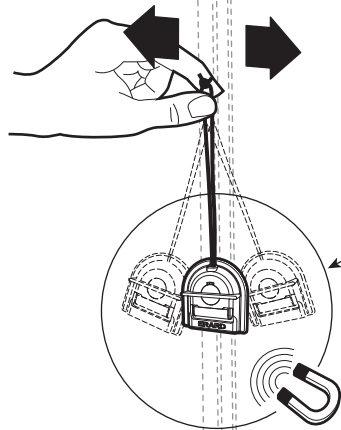

**A** **B** **C** 16 x 4 + 3



Ø10

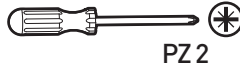
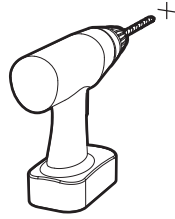

PZ2

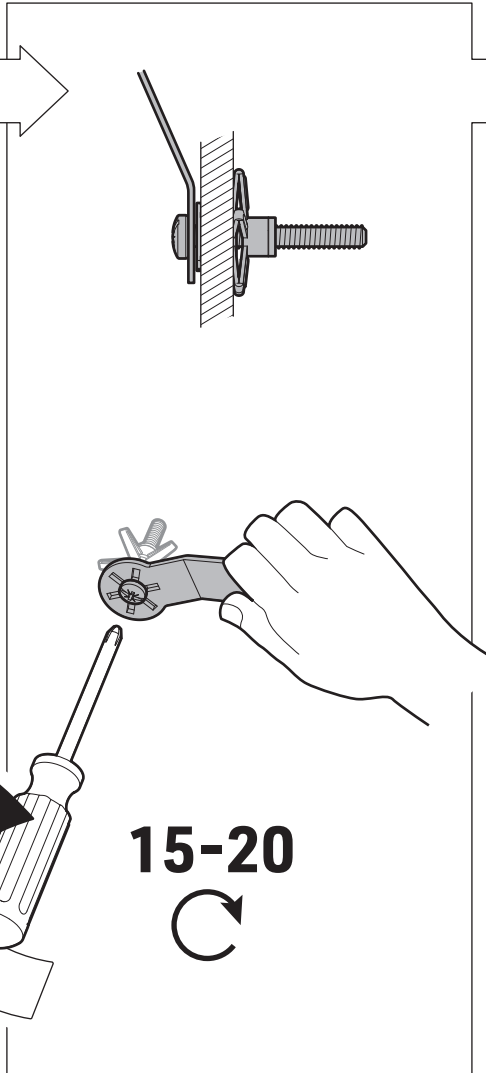
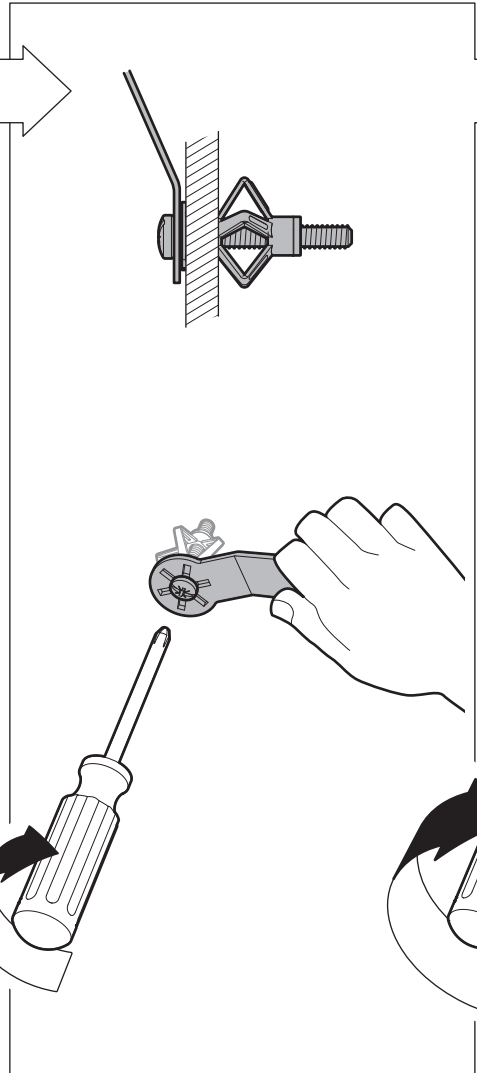
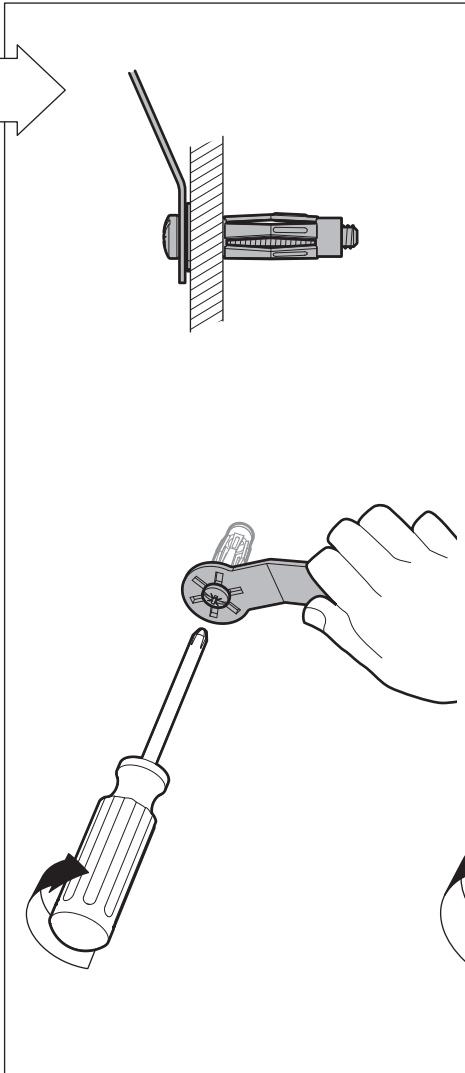
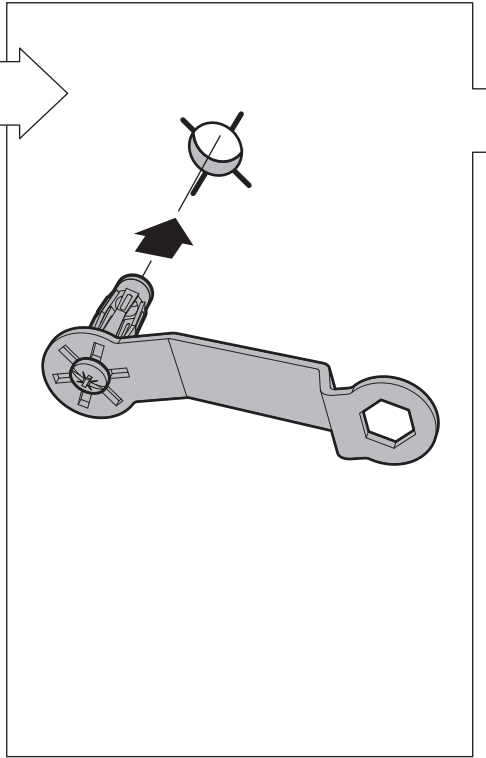
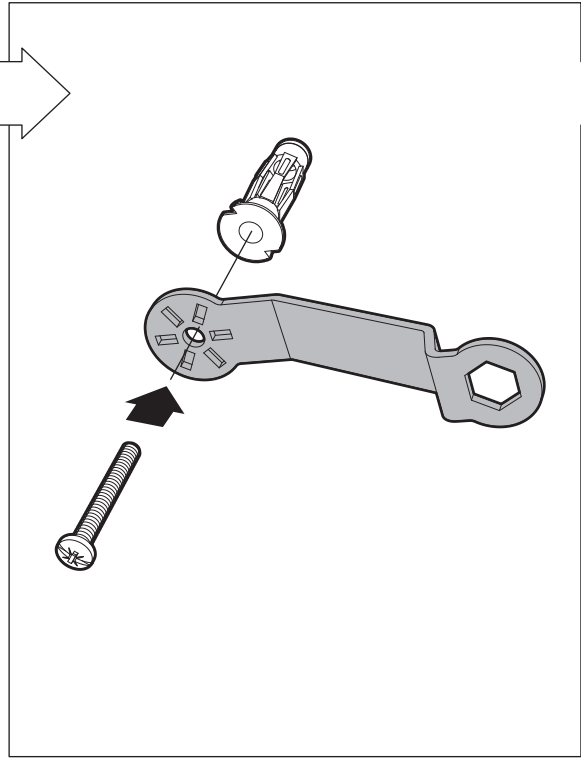
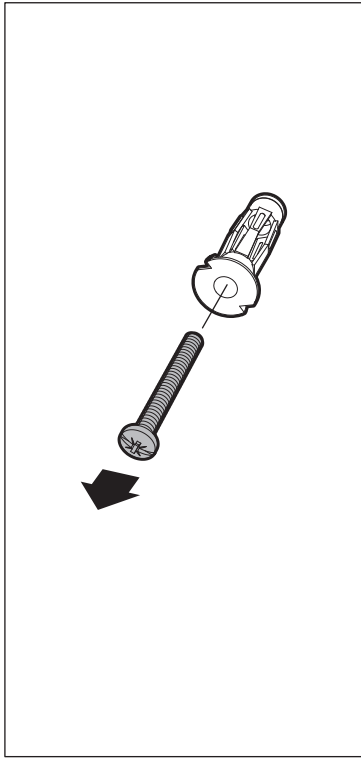

**15-20**  
↻

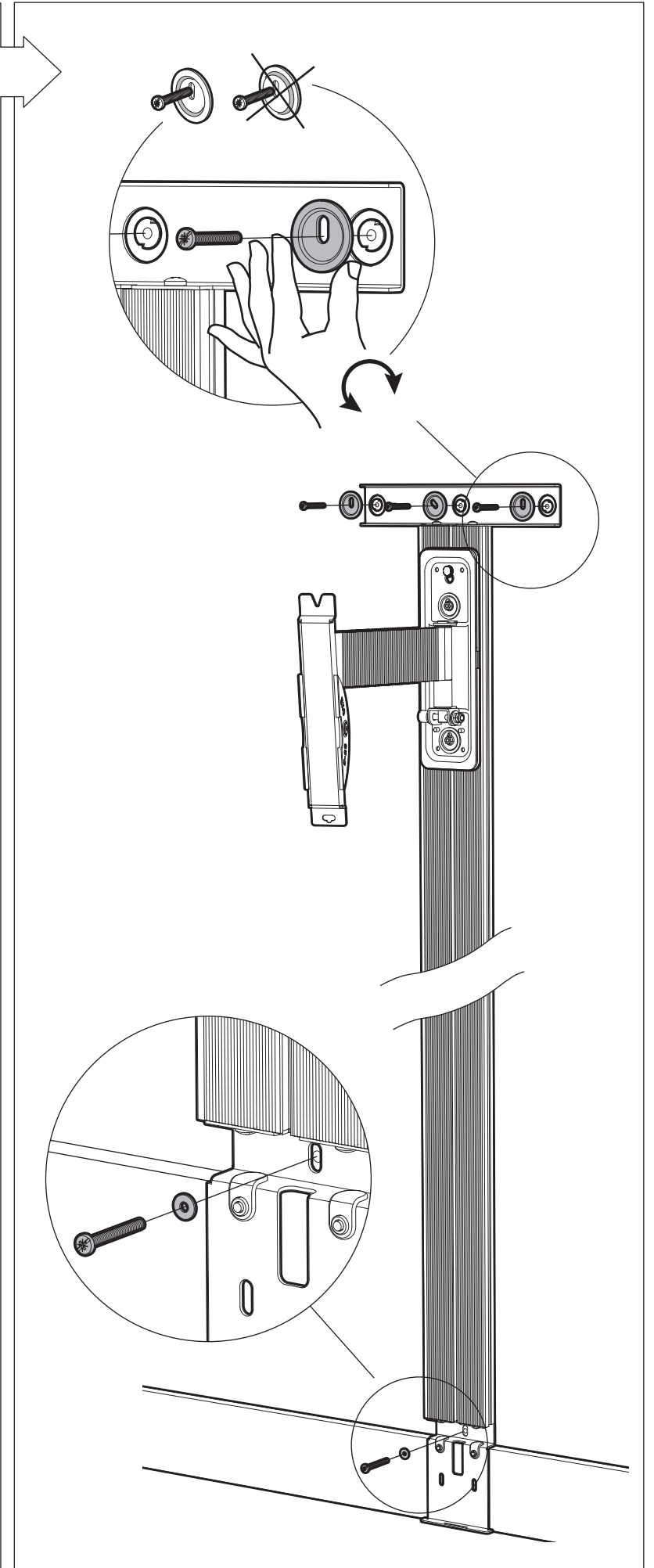
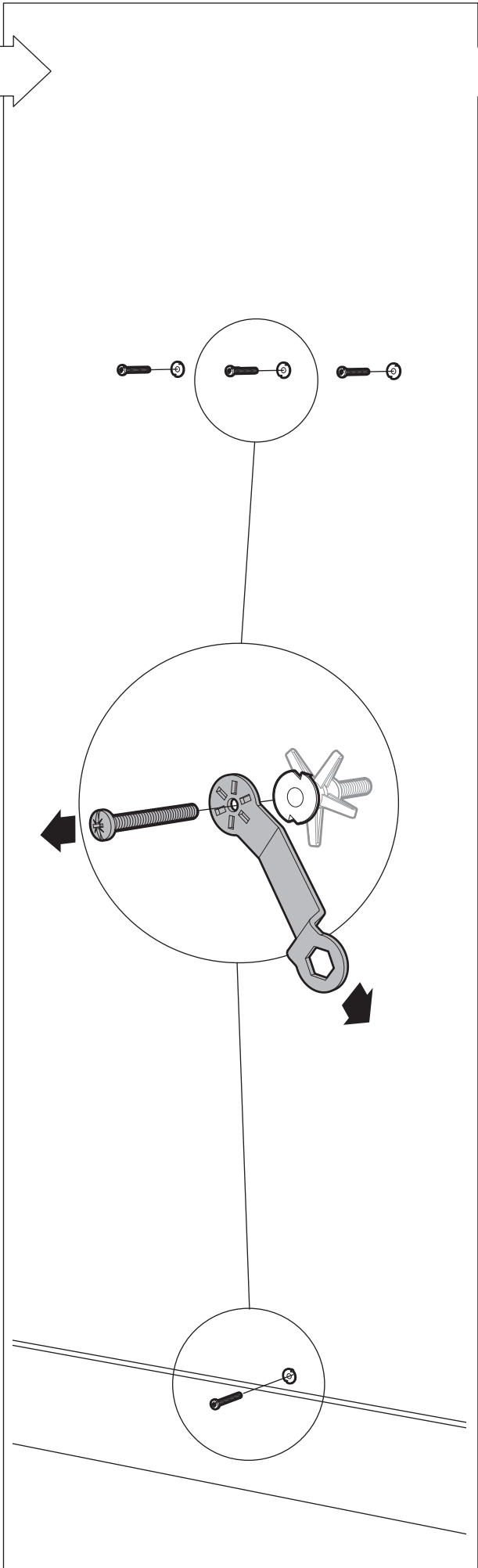

14

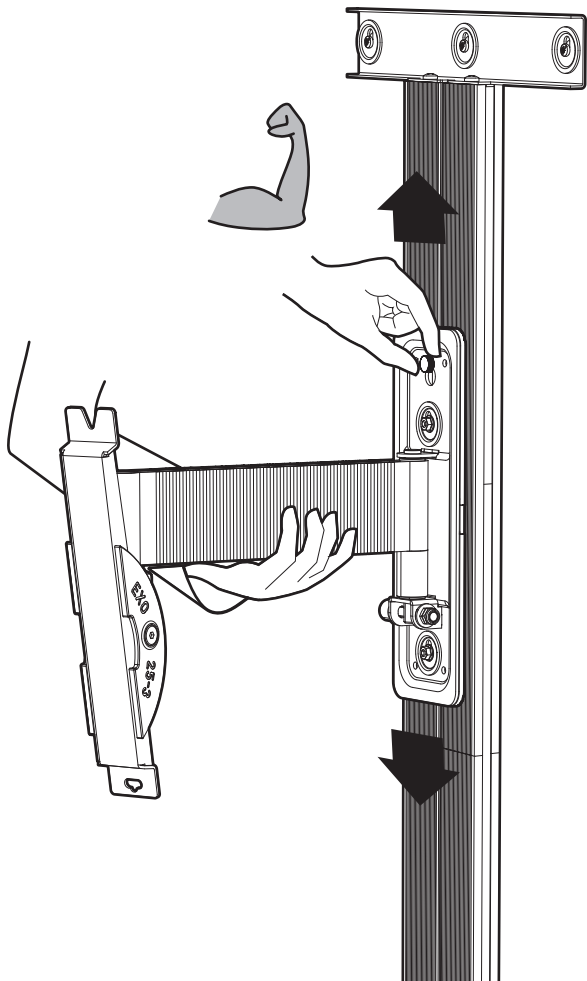

15 ③

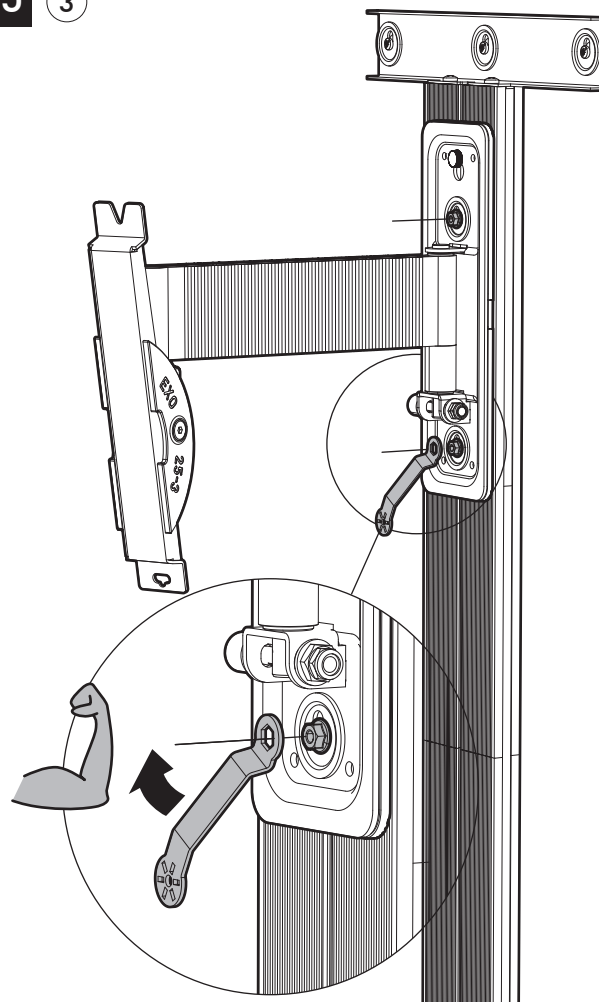

16 (B) + (C)

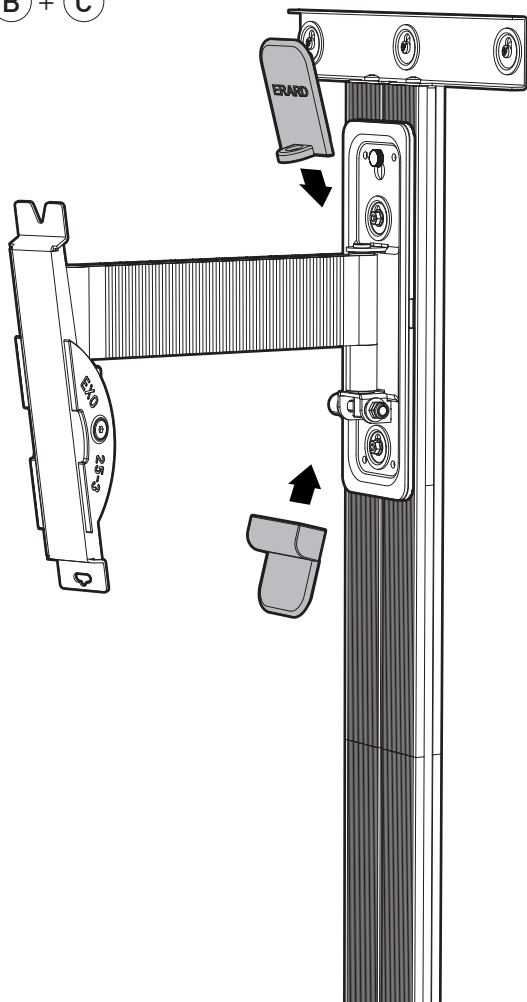

17 (Q) + (R)

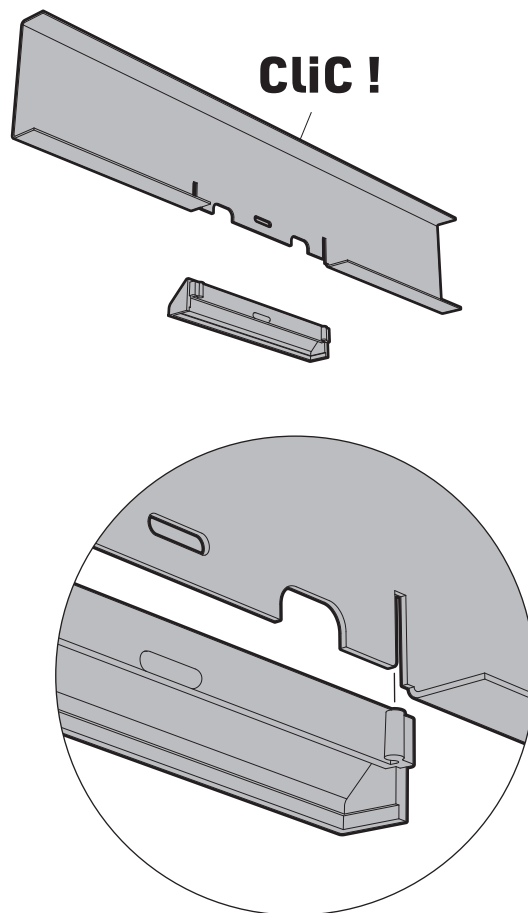

18 (Q) + (R) + (X) x2

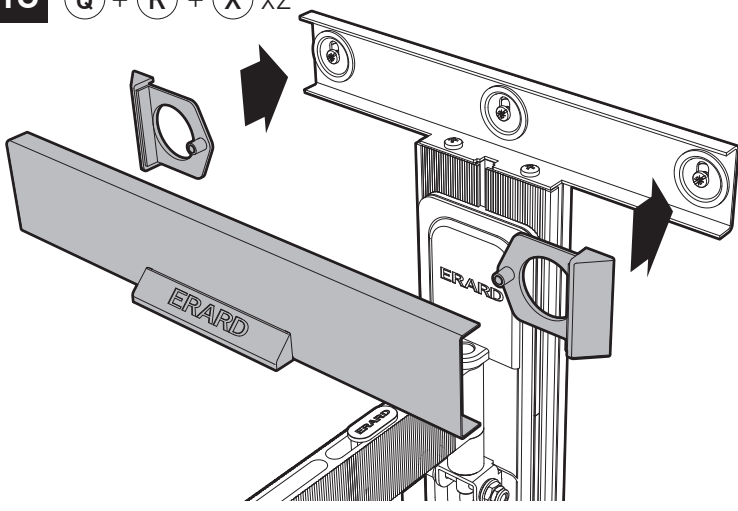

19 (AA)

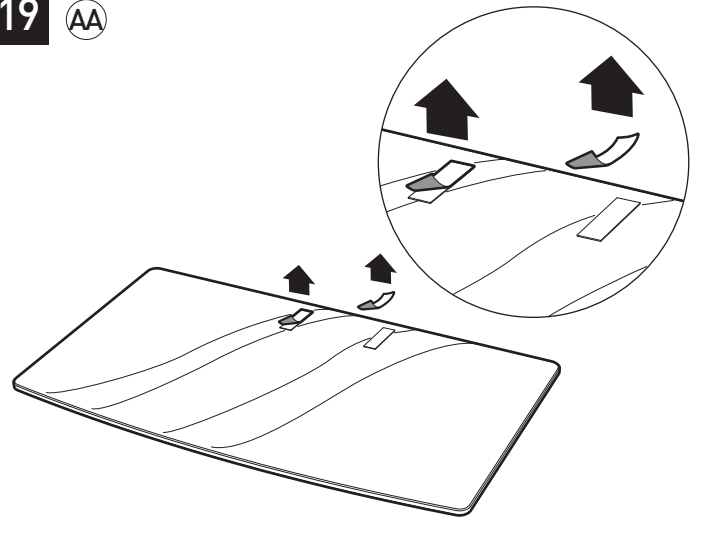

20 (Y) +

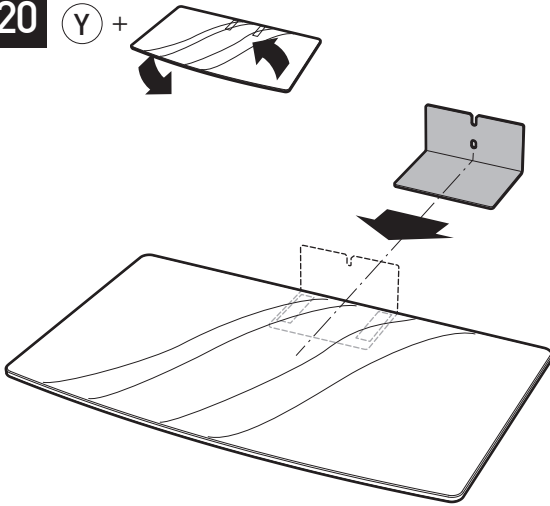

21 (Z)

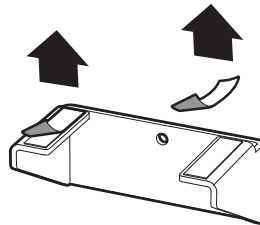

22 (AA) + (Y) + (Z)

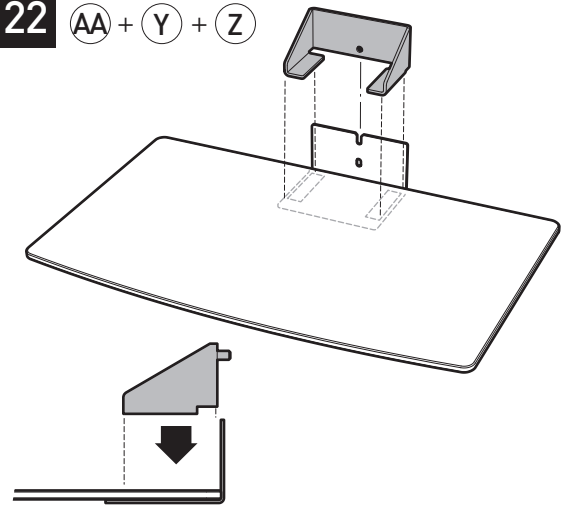

23 (T1) + (T2)

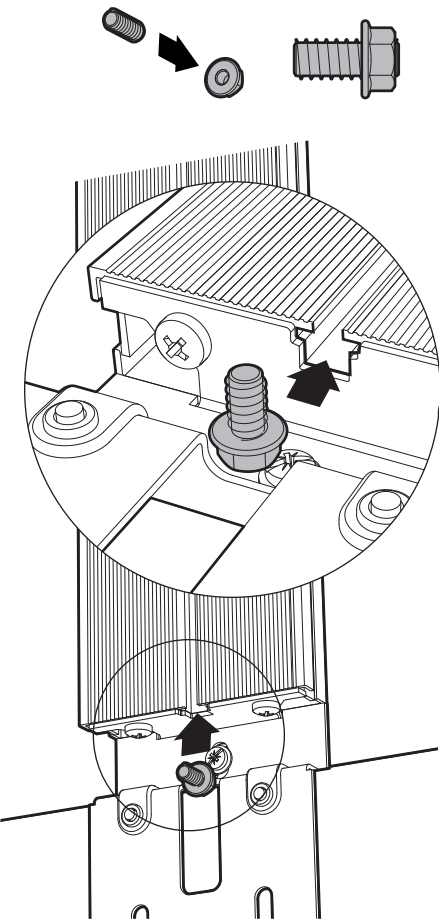

24

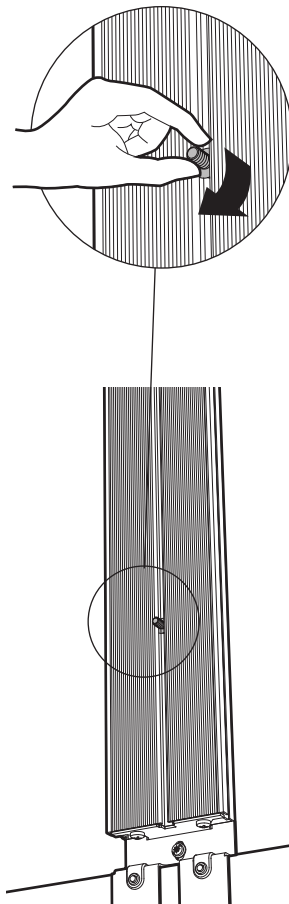

25 (T2) x1

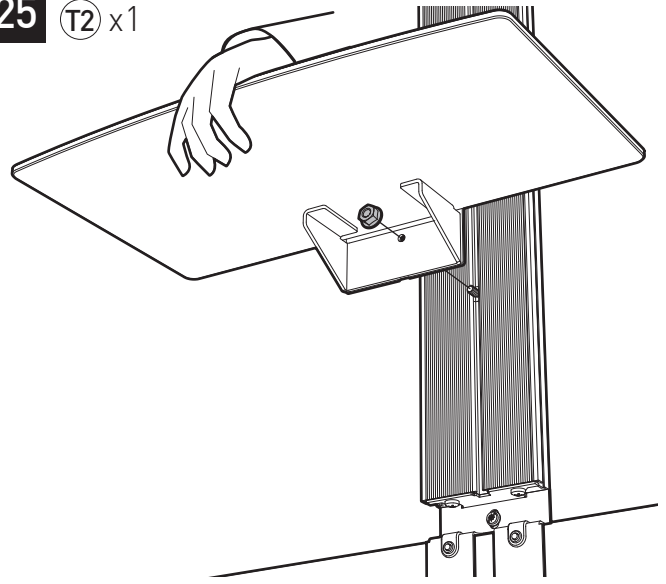

26 (3)

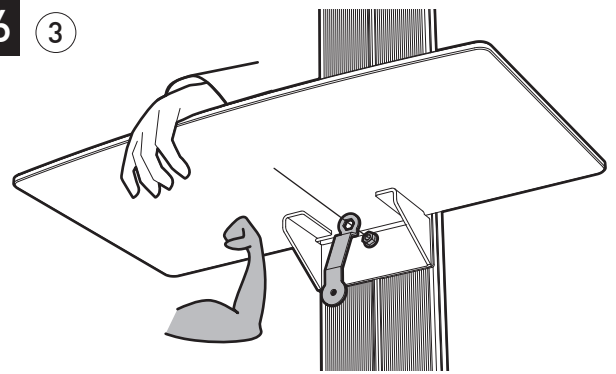

27

4 + #

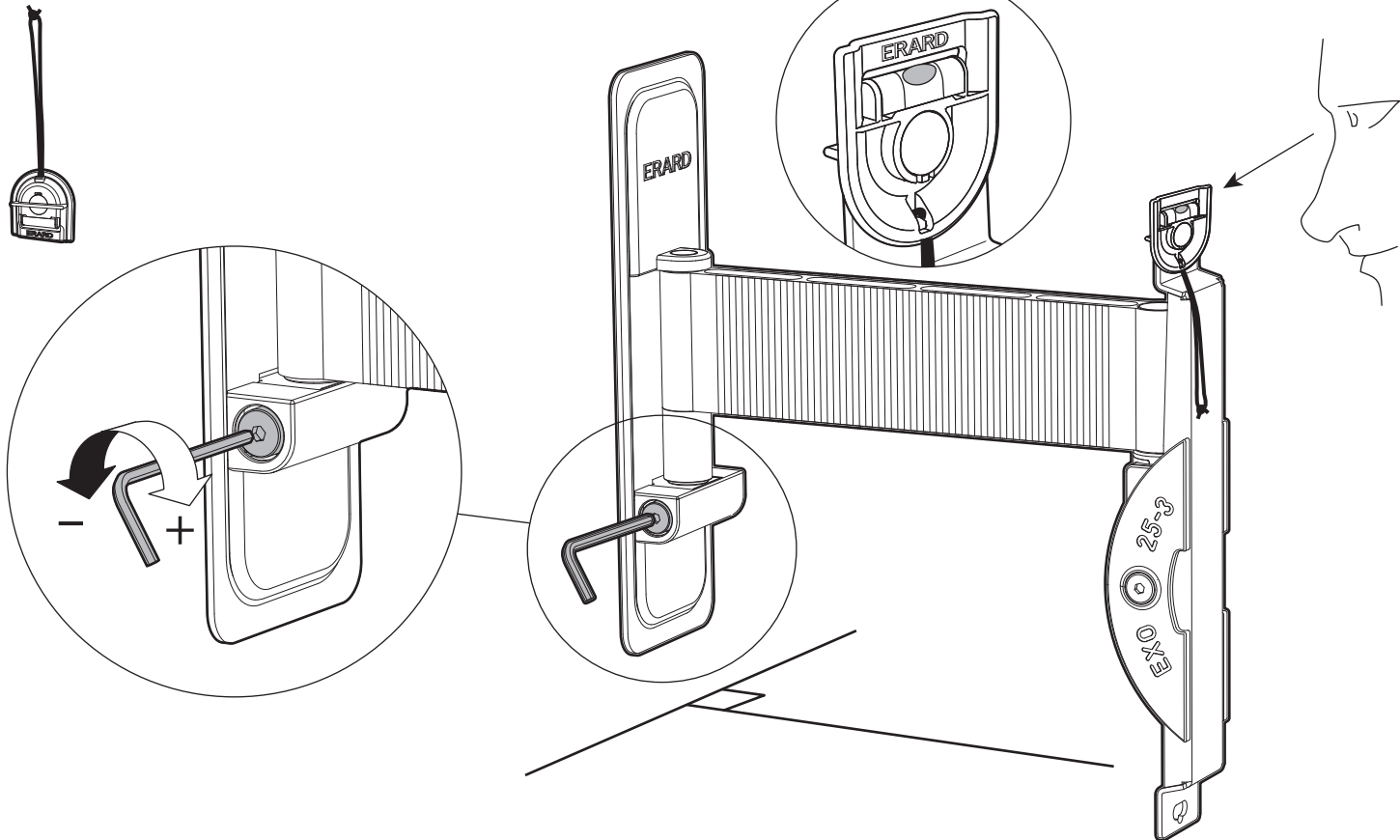

28

G x2 + H x4 + J x4 + 11 x4 + 5



L ?

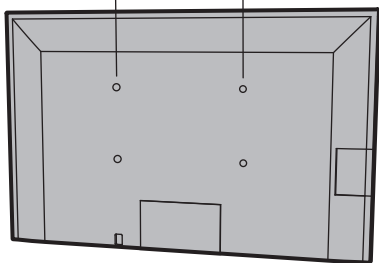

L = 200 mm  
 300  
 400  
 500  
 600

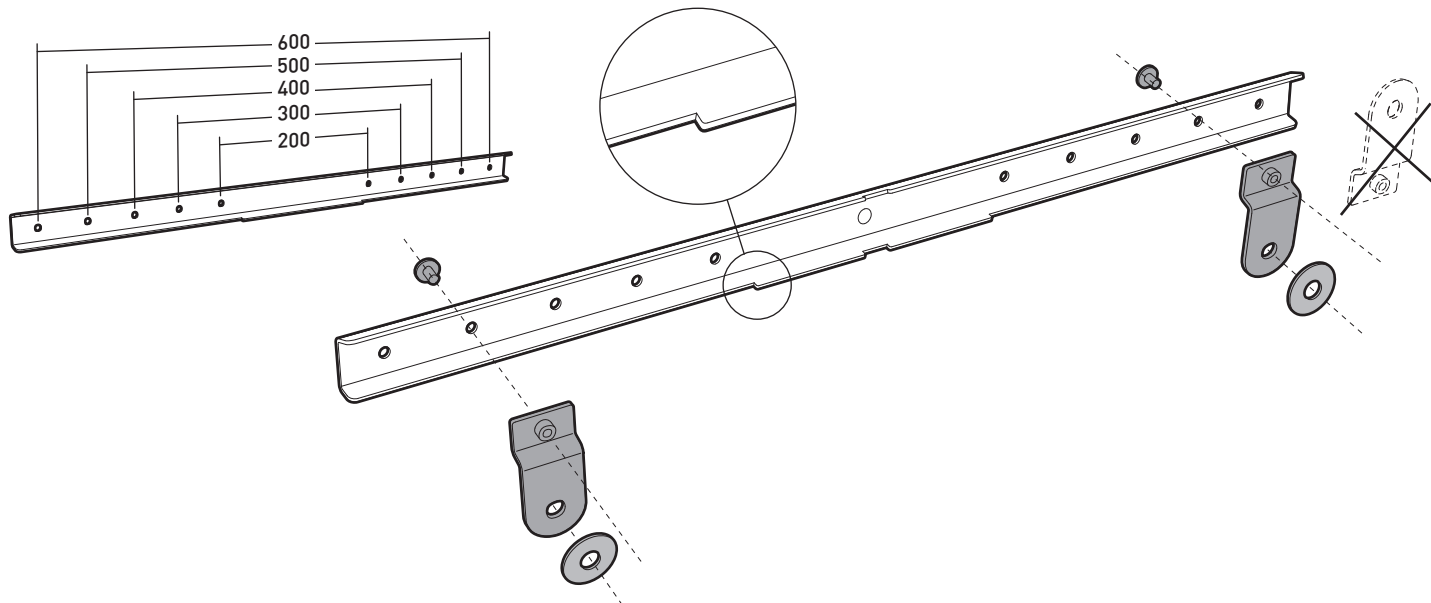

29

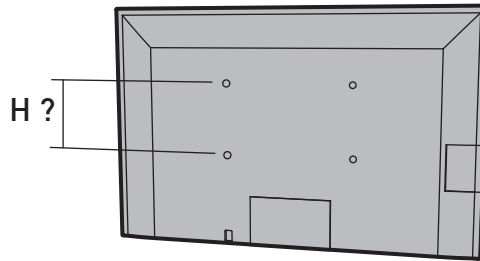
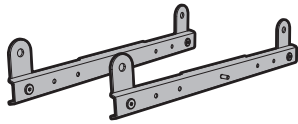

H = 200 mm  
300  
400

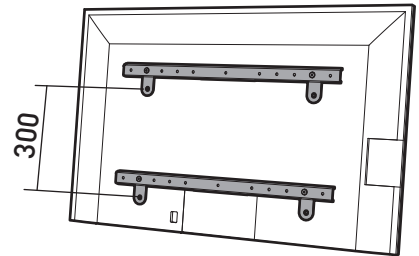
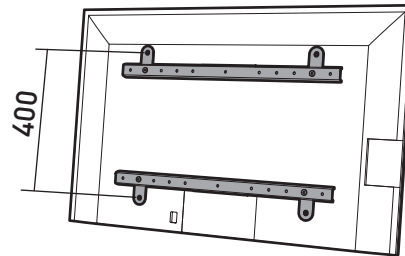
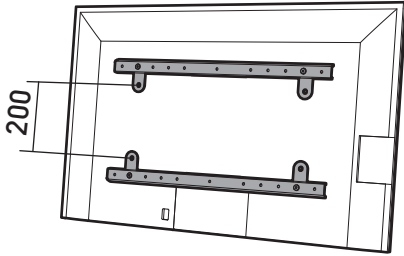

30

0 + 1 + 2

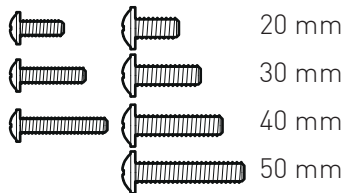
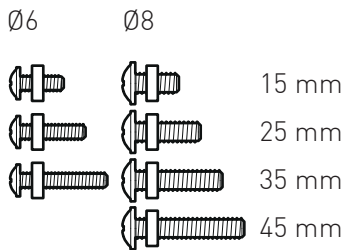
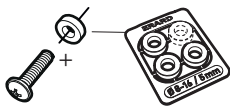
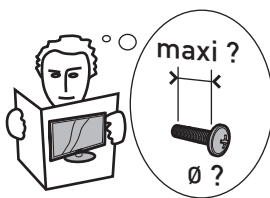

31 ?

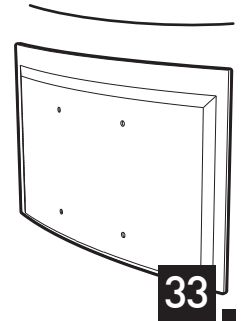
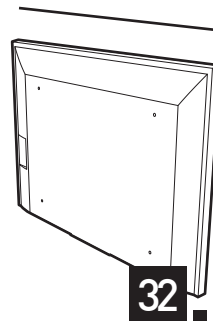

32

0 1 2 x 4 + D x 4 +

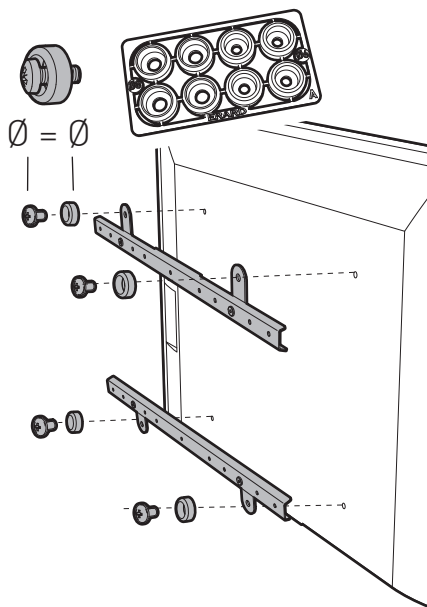
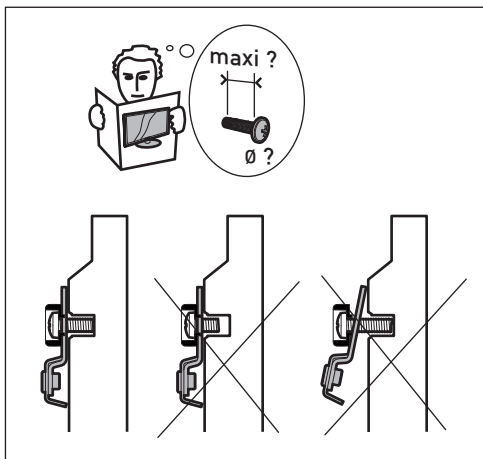
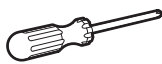

33

⓪ ① ② x 4 + ⓓ x 4 + ⓘ x 4/8 

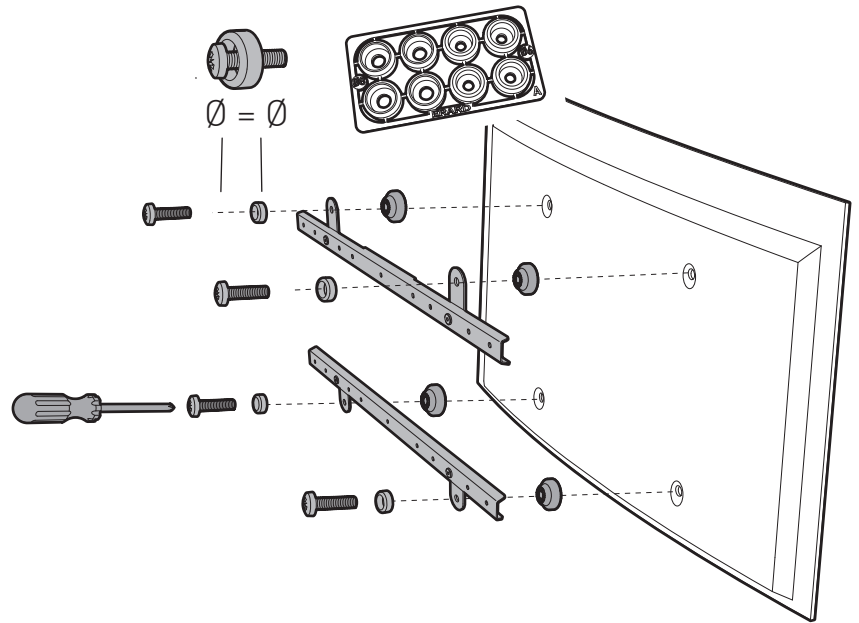
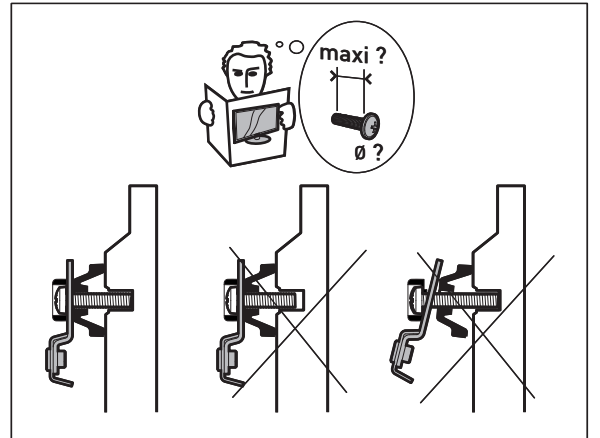
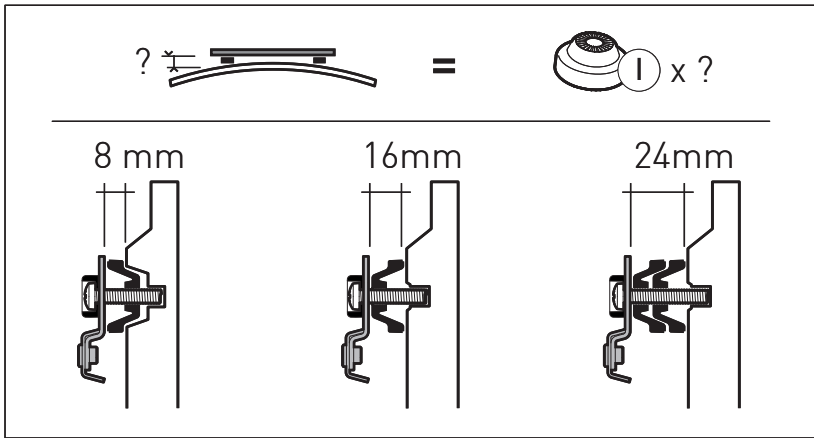

34

⑫ x 1

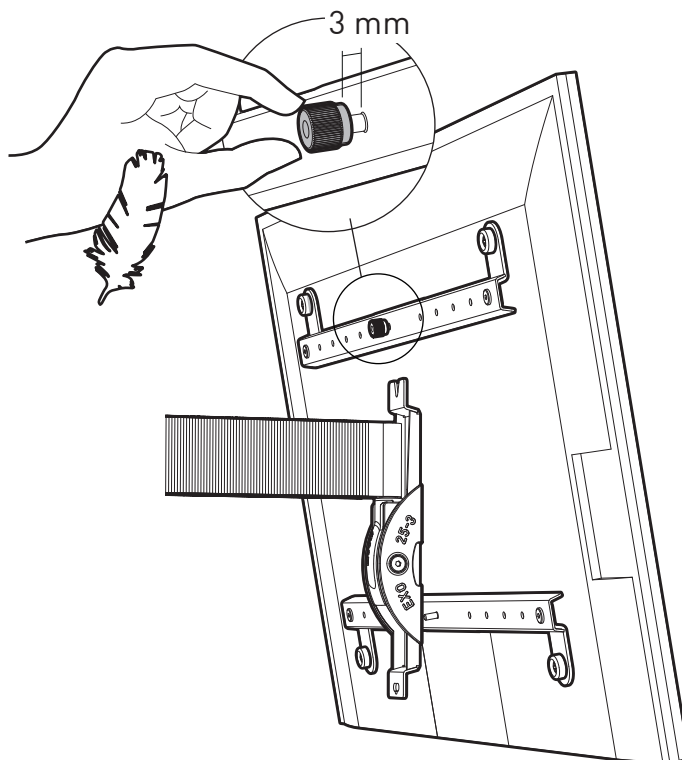

35 (12) x1 + #

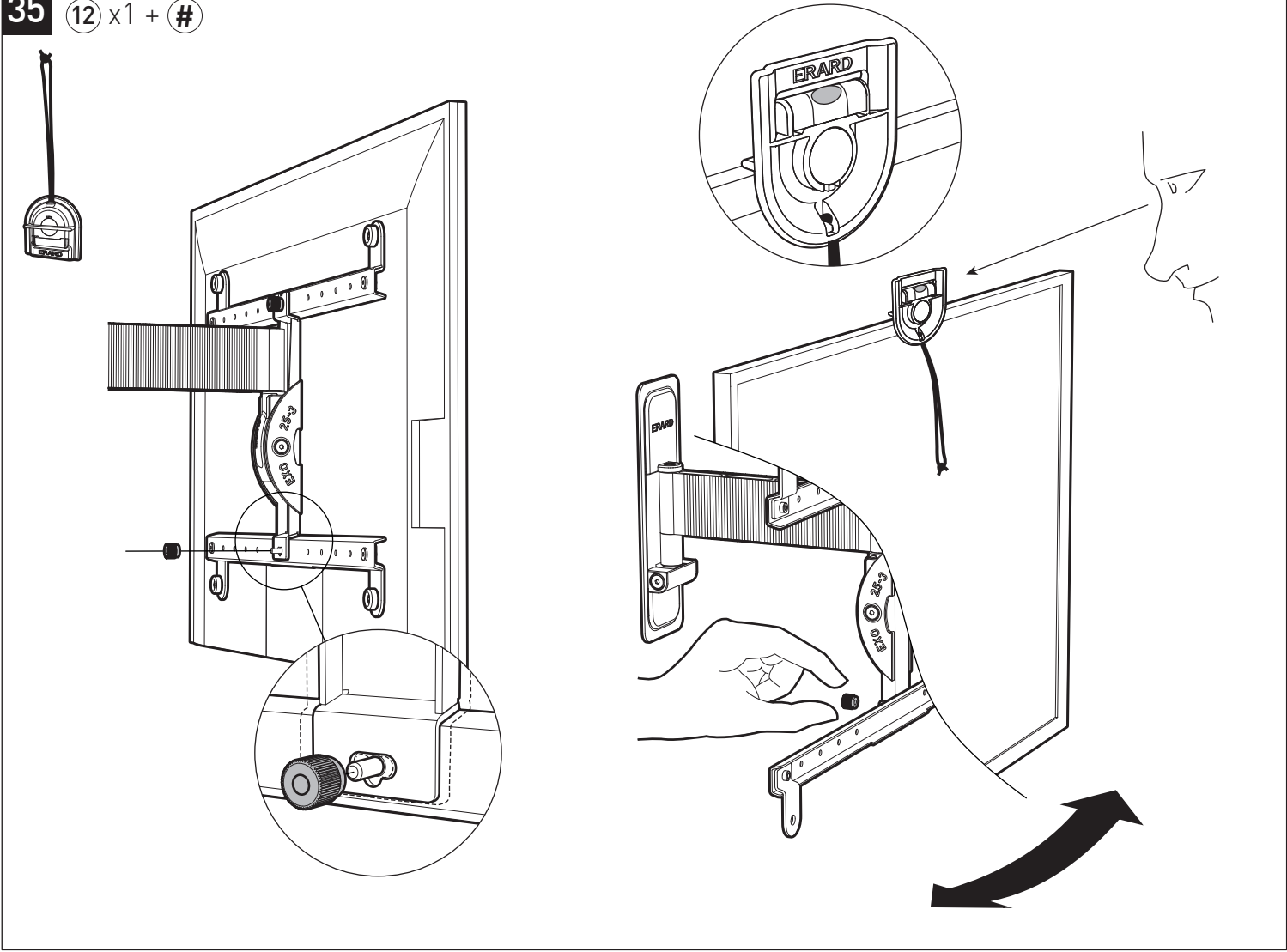

36

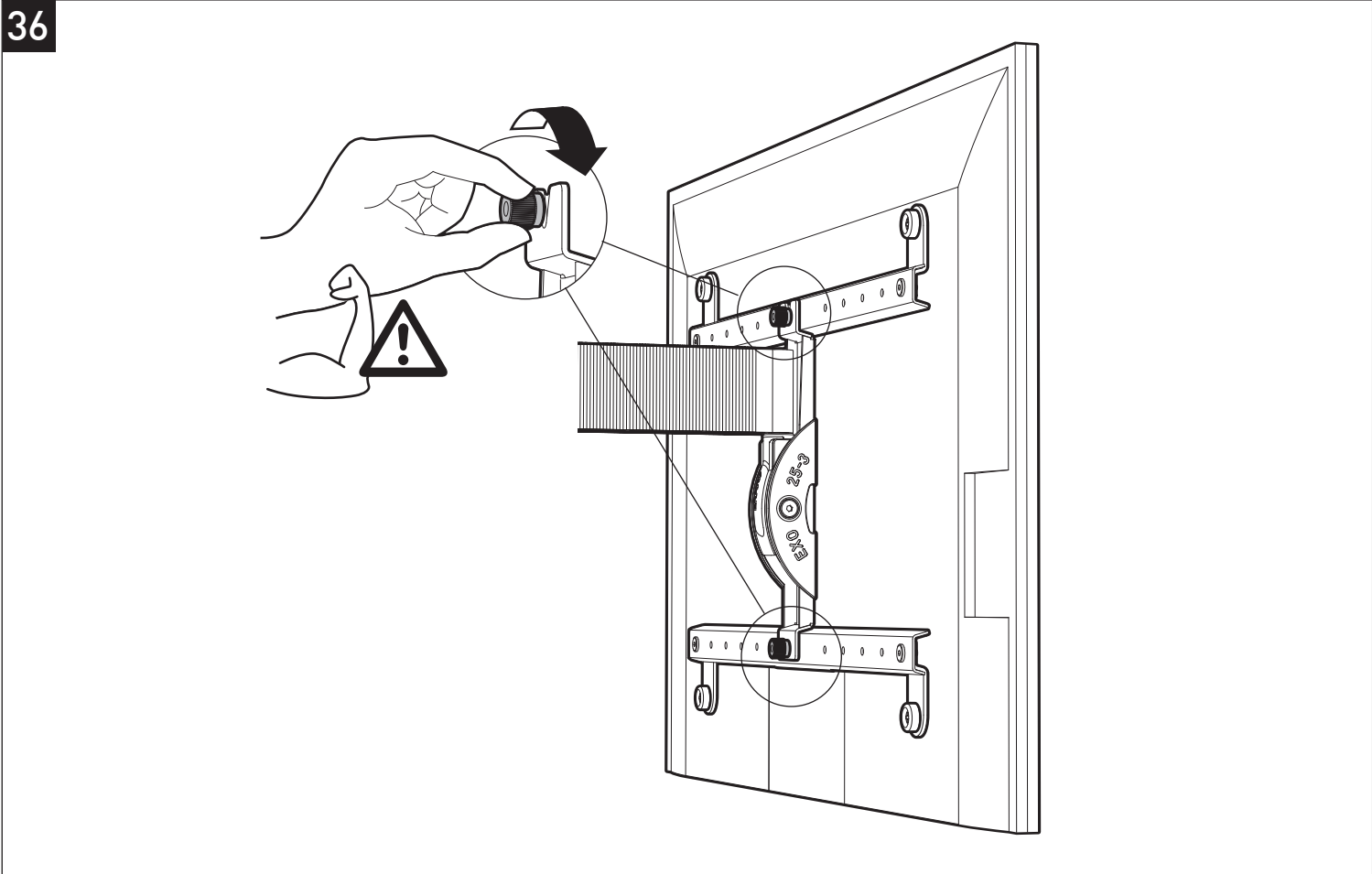

37 E + F

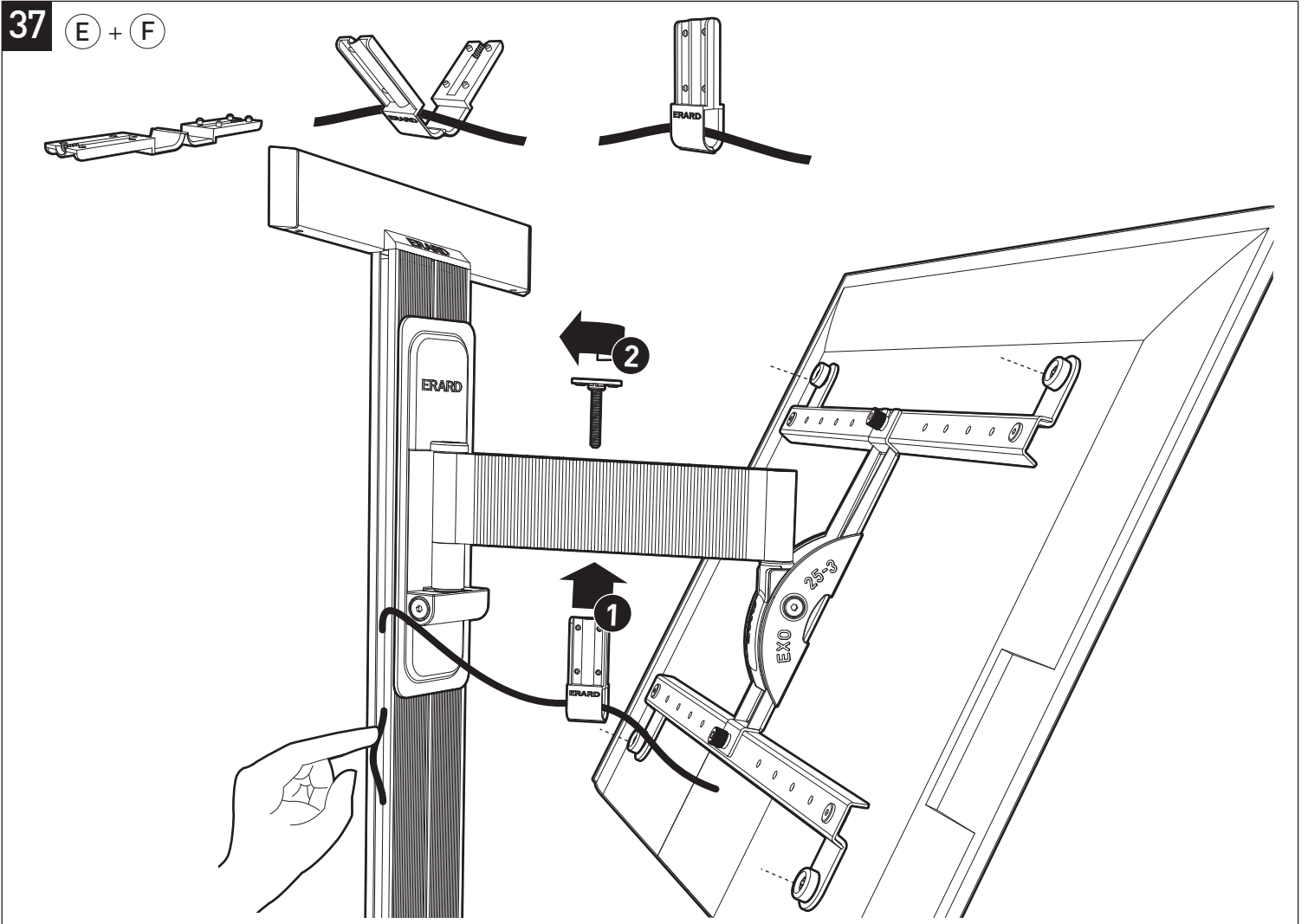

38 ⑤ x2

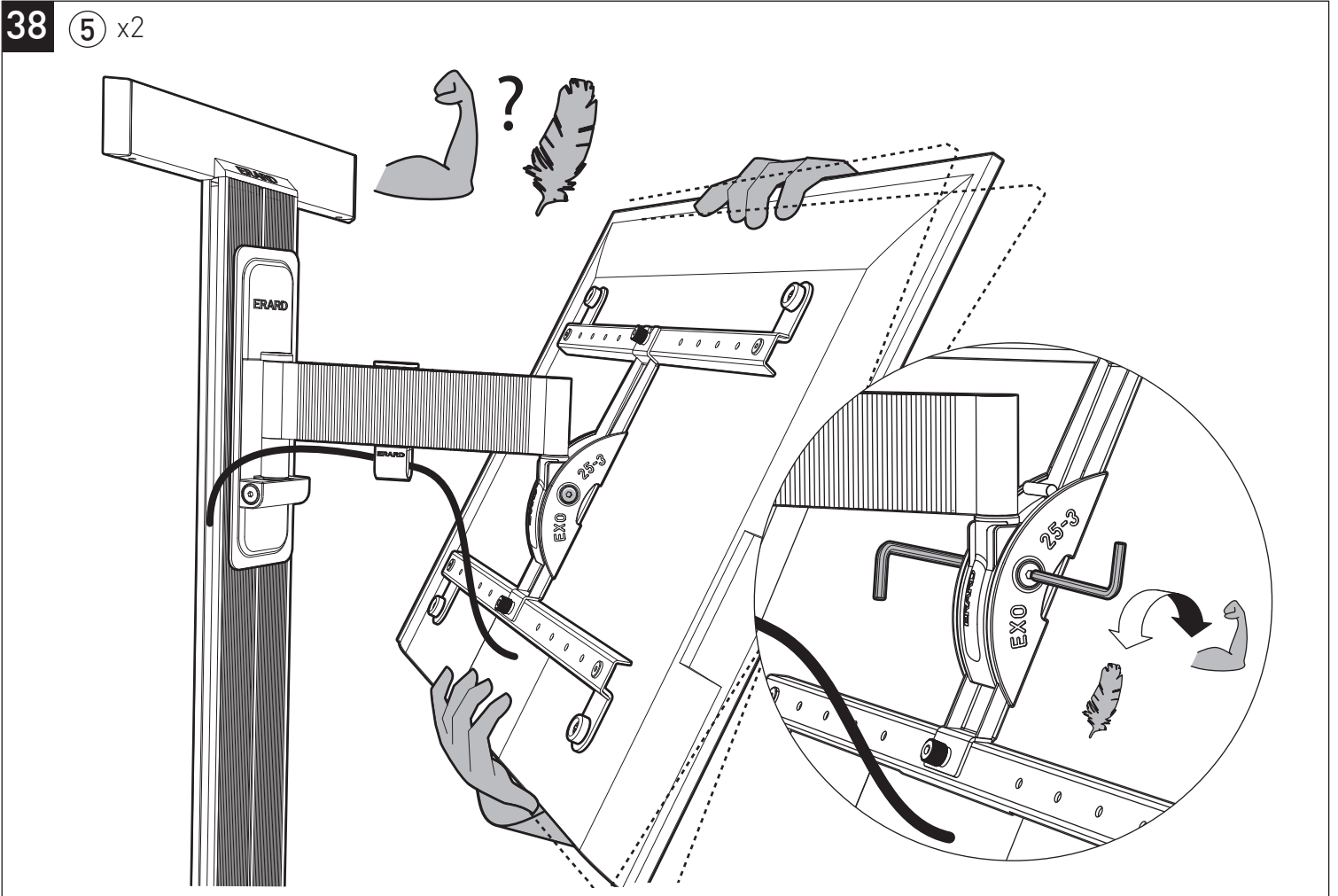

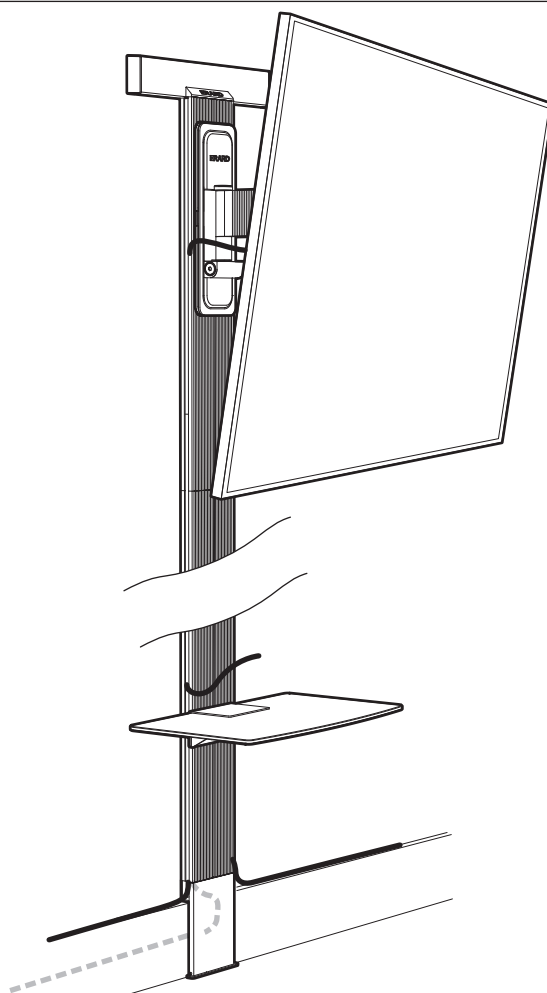
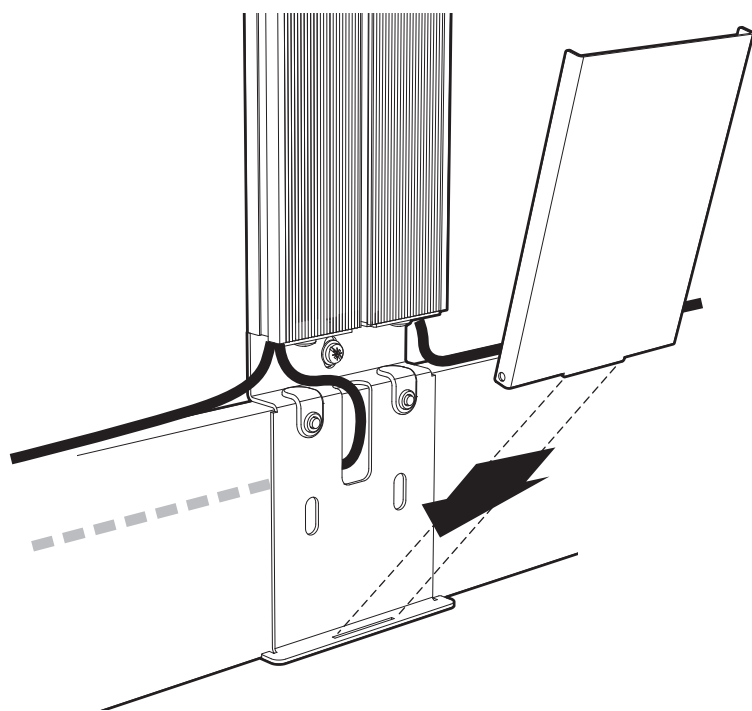

## \*

- FR** Fixation : Pour garantir une installation sûre et durable sur les cloisons de plâtre, vous devez obligatoirement vous conformer aux indications de cette notice et utiliser les composants fournis avec le produit. Les cloisons de plâtre doivent être d'une épaisseur minimale de 10mm (type BA10 ou BA13) et respecter la norme EN 520+A1:2009. Elles doivent aussi être parfaitement saines, exemptes d'humidité et sans marque de détérioration. Dans le cas de cloisons plus épaisses, supérieures à 13mm, il est indispensable de s'approvisionner de vis à expansion adaptées à l'épaisseur de votre cloison. Pour plus d'information vous pouvez contacter notre Service Après-Vente qui vous guidera dans cette démarche.
- GB** Fixing in place: to ensure secure, permanent installation on plasterboard partitions, you must follow the instructions in this manual and use the components supplied with the product. The plasterboard partitions must be at least 10 mm thick (type BA10 or BA13) and comply with the standard EN 520+A1:2009. They must also be in a perfectly sound condition, free of moisture and without any signs of wear and tear. For thicker walls (over 13 mm), you will need to purchase expansion screws suitable for the thickness of your partition. For more information, you can contact our After-Sales Service team, who will guide you through this process.
- DE** Befestigung: Zur Gewährleistung einer sicheren und dauerhaften Anbringung an den Gipswänden sind die Hinweise dieser Anleitung strikt einzuhalten und die mit dem Produkt bereitgestellten Komponenten zu verwenden. Die Gipswände müssen eine Mindestdicke von 10 mm (Typ BA10 oder BA13) aufweisen und der Norm EN 520+A1:2009 entsprechen. Sie müssen außerdem ganz und gar unversehrt, frei von Feuchtigkeit und ohne Beschädigungen sein. Im Falle von Wänden mit einer Dicke von über 13 mm ist es unabdingbar, zusätzlich auf die Dicke der Wand abgestimmte Expansionsschrauben zu verwenden. Kontaktieren Sie für weitere Informationen unseren Kundendienst, der Sie dabei gerne anleiten wird.
- ES** Fijación: para garantizar una instalación segura y duradera en los tabiques de yeso, debe cumplir obligatoriamente las instrucciones de este manual y utilizar los componentes suministrados con el producto. Los tabiques de yeso deben tener un grosor mínimo de 10 mm (tipo BA10 o BA13) y cumplir la norma EN 520+A1:2009. También deben ser robustos y estar libres de humedad y sin signos de deterioro. En el caso de tabiques más gruesos, de más de 13 mm, es esencial comprar tornillos de expansión adaptados al grosor de su tabique. Para más información puede contactar con nuestro servicio de atención al cliente que le guiará a través de este proceso.
- IT** Fissaggio: al fine di garantire un'installazione sicura e duratura su tramezzi in gesso, è necessario rispettare le indicazioni contenute nelle presenti istruzioni e utilizzare i componenti forniti insieme al prodotto. I tramezzi in gesso devono essere spessi almeno 10 mm (tipo BA10 o BA13) e conformi alla norma EN 520+A1:2009. Devono inoltre essere perfettamente integri e non presentare né tracce di umidità né segni di deterioramento. In caso di tramezzi di spessore maggiore (> 13 mm), è necessario dotarsi di viti di espansione adeguate allo spessore del proprio tramezzo. Per maggiori informazioni in merito e conoscere la soluzione più opportuna, si prega di contattare l'Assistenza post-vendita.
- NL** Bevestigen: Om een stabiele en duurzame installatie op wanden uit gipsplaat te garanderen moet u de instructies in deze handleiding nauwkeurig opvolgen en moet u de met het product meegeleverde accessoires gebruiken. De wanden uit gipsplaat moeten minimaal 10 mm dik zijn (type BA10 of BA13) en ze moeten voldoen aan de norm: EN 520+A1:2009. Ze moeten ook in perfecte staat en vochtvrij zijn en ook geen sporen van beschadiging vertonen. Als het dikkere wanden betreft, d.w.z. meer dan 13 mm, dan moet er gewerkt worden met expansiepluggen die geschikt zijn voor de dikte van uw wand. Voor meer informatie kunt u contact opnemen met onze klantendienst. Deze zal u bij uw werk verder begeleiden.
- PT** Fixação: para garantir uma instalação segura e duradoura em paredes de gesso, as instruções deste manual devem ser obrigatoriamente cumpridas e devem ser utilizados os componentes fornecidos com o produto. As paredes de gesso têm de ter uma espessura mínima de 10 mm (tipo BA10 ou BA13) e estar em conformidade com a Norma EN 520+A1:2009. As mesmas devem estar em perfeito estado, isentas de humidade e sem sinais de deterioração. No caso de paredes mais espessas — com uma espessura superior a 13 mm — é indispensável adquirir parafusos de expansão adaptados à espessura da respetiva parede. Para obter mais informações, contacte o nosso serviço de assistência ao cliente, que irá fornecer-lhe as orientações necessárias.

Votre produit ERARD a été soumis à tous les essais requis et remplit toutes les exigences de sécurité applicables. Il est garanti à vie contre tout défaut de fabrication. La garantie à vie ERARD est gratuite, personnelle et non transmissible. Les modalités d'exercice de la présente garantie sont précisées dans les « conditions générales de vente » et dans la « charte SAV-garantie » (disponibles sur simple demande ou consultables sur le site [www.erard.com](http://www.erard.com)).

#### Conditions de garantie

Pour bénéficier de cette garantie, vous devez contacter le service consommateur (numéro vert : 0 800 40 40 60) et leur transmettre une copie de la facture originale précisant la date d'achat, le nom du revendeur ainsi que le bon de garantie indiquant le type de produit et son numéro de série.

Toutefois, la garantie ne couvre pas les cas suivants :

- Les pièces d'usure normale : bague de friction, axe de rotation, cache plastique, [Les pièces d'usure normale sont garanties 2 ans conformément à la charte SAV ERARD].
- Dommages causés par négligence, installation défectueuse, utilisation anormale contraire ou non conforme aux recommandations de ce manuel (Impacts, rayures etc...).
- Dommages liés à une cause extérieure à l'appareil : chute du produit, dégat des eaux, incendie, foudre etc.
- Dommages liés à toute modification ou réparation effectuée par des personnes non mandatées par ERARD.
- Dommages liés au stockage du produit avant installation du produit.
- Tout dommage durant le transport, liés à l'exécution de cette garantie.

#### Avvertissement

Les vis et les chevilles fournies avec les supports ERARD sont prévues pour des murs en matériaux durs et pleins (béton, brique pleine...). Pour les autres matériaux, utiliser des systèmes de fixation adaptés à la qualité du mur et au poids à supporter.

#### Recyclage en fin de vie

Pour contribuer à la protection de l'environnement, utiliser les méthodes d'élimination et de récupération des emballages appropriés.

Les cartons utilisés pour l'emballage de ce produit peuvent être recyclés ou réutilisés.

Your ERARD product has been subject to quality control and meets all of the applicable safety standards. Nonetheless, should any manufacture or material faults become apparent, ERARD undertakes to replace the defective part(s). It is guaranteed for life against all manufacturing defects. The ERARD lifetime warranty is free, personal and non-transferable.

For details of the warranty procedure, please refer to the "General Terms of Sale" and the "After Sales Warranty Charter" (available on request or viewable on [www.erard.com](http://www.erard.com)).

#### Terms of Warranty

To benefit from this guarantee, please contact our customer service (+33 [0]4 72 46 16 26) and supply us with a copy of the original invoice showing the date of purchase and the name of the dealer, as well as the certificate of guarantee indicating the product type and the serial number.

The guarantee does not cover the following:

- List of wear parts: friction ring, rotation axis, plastic cover (Wear parts are guaranteed 2 years in accordance with the ERARD customer charter).
- Damages caused by neglect, faulty installation, abnormal use contrary or not in accordance with the recommendations of this manual (impacts, scratches, etc.).
- Damage due to external causes, unrelated to the product: falling product, water damage, fire, lightning, etc.
- Damage related to any modification or repair made by persons not authorised to do so by ERARD.
- Damage related to the storage of the product before installation.
- Any damage during transport related to the conditions of this warranty.

#### Warning

Screws and plastic anchors provided with ERARD brackets are compatible with hard and full wall materials (concrete, solid brick...). For other materials, use fasteners adapted to the quality of the wall and the load to be supported.

#### End-of-life recycling

To help to protect the environment, use the appropriate recycling and discarding methods for the packaging.

The boxes used for the packaging of this product may be recycled or re-used.

Dieses ERARD Produkt wurde allen erforderlichen Tests unterzogen und erfüllt alle einschlägigen Sicherheitsforderungen. Wir gewähren auf dieses Produkt eine lebenslange Herstellergarantie auf jegliche Herstellungsfehler. Die lebenslange ERARD-Garantie ist kostenlos, persönlich und nicht übertragbar.

Die Modalitäten zur Inanspruchnahme dieser Garantie sind in den "Allgemeinen Verkaufsbedingungen" und in der "Kundenservice- und Garantie-Charta" festgelegt

(die Sie jederzeit bei uns anfordern können und zudem auf unserer Website [www.erard.com](http://www.erard.com) finden).

#### Garantiebedingungen

Um diese Garantie geltend zu machen, wenden Sie sich bitte an unseren Kundenservice (+33 [0]4 72 46 16 26) und schicken ihm eine Kopie der Originalrechnung mit dem Kaufdatum und dem Namen des Händlers sowie die Garantiekarte mit der Angabe des Produkttyps und der Seriennummer.

Die folgenden Fälle sind von der Garantie jedoch nicht abgedeckt:

- Teile, die normalem Verschleiß unterliegen, wie z. B.: Reibring, Drehachse, Kunststoffabdeckung, Klebepad. (Verschleißteile haben eine 2-jährige Garantie gemäß der KD ERARD Charta).
- Schäden, die durch Fahrlässigkeit, fehlerhafte Installation, unsachgemäßen Gebrauch oder entgegen den Empfehlungen dieser Anleitung verursacht wurden (Stöße, Kratzer, usw.).
- Schäden, die auf eine Ursache außerhalb des Geräts zurückzuführen sind: Herunterfallen des Produkts, Wasserschäden, Feuer, Blitzschlag, usw.
- Schäden im Zusammenhang mit Änderungen oder Reparaturen, die von Personen durchgeführt werden, die nicht von ERARD genehmigt wurden.
- Schäden im Zusammenhang mit der Lagerung des Produkts vor dessen Installation.
- Transportschäden, die im Zusammenhang mit der Ausführung dieser Garantie stehen.

#### Warnung

Die mitgelieferten Schrauben und Dübel sind für Mauern aus harten und vollen Materialien vorgesehen (Beton, voller Ziegelstein...). Für die anderen Materialien Befestigungssysteme benutzen, die der Qualität der Mauer und an das zu tragende Gewicht angepasst sind.

#### Recycling am Lebensende

Aus Gründen des Umweltschutzes beachten Sie beim Entsorgen der Verpackung stets die örtlichen Vorschriften und Recyclingmöglichkeiten.

Die für die Verpackung dieses Produkts verwendeten Kartons können dem Recycling zugeführt und weiter verwertet werden.

Su producto ERARD se ha sometido a todas las pruebas requeridas y ha cumplido todas las exigencias de seguridad aplicables. Está garantizado de por vida contra defectos de fabricación. La garantía ilimitada de ERARD es gratuita, personal e intransferible. Las modalidades de ejercicio de la presente garantía se especifican en las condiciones generales de venta y en la "carta SAV-garantía" (disponibles mediante pedido o en la página web [www.erard.com](http://www.erard.com)).

#### Condiciones de garantía

Para beneficiarse de esta garantía, debe ponerse en contacto con el servicio de atención al cliente (número gratuito: +33 [0]4 72 46 16 26) y enviarle una copia de la factura original en la que conste la fecha de compra y el nombre del vendedor así como la ficha de garantía que indique el tipo de producto y su número de serie.

La garantía no cubre los casos siguientes :

- Las piezas con un desgaste normal, es decir: anillo de fricción, eje de rotación, tapa de plástico, cinta adhesiva. (Las piezas con un desgaste normal tienen una garantía de 2 años de acuerdo con la política de SAV ERARD).
- Daños ocasionados por negligencia, instalación defectuosa, uso anormal o por no respetar las recomendaciones de este manual (golpes, arañazos, etc.).
- Daños ocasionados por motivo externa al aparato: caída del producto, desgaste del agua, incendio, rayos, etc.
- Daños ocasionados por cualquier modificación o reparación realizada por personas ajenas a ERARD.
- Daños ocasionados por el almacenamiento del producto antes de su instalación.
- Cualquier daño durante el transporte, vinculado con el cumplimiento de esta garantía.

#### Advertencia

Los tornillos y las clavijas proporcionados con los soportes ERARD están diseñados para paredes de materiales duros y macizos (hormigón, ladrillo macizo.... Para otros materiales, utilice sistemas de fijación adaptados a la calidad de la pared y a la carga que soportarán.

#### Reciclaje al final de su vida útil

Para contribuir a la protección del medio ambiente, utilice los métodos de eliminación y de reciclaje apropiados para los embalajes.

Las cajas utilizadas para el embalaje de este producto pueden reciclarse o reutilizarse.

Il prodotto ERARD è stato soggetto a tutti i collaudi richiesti e soddisfa tutte le esigenze di sicurezza applicabili. È garantito a vita per quanto riguarda tutti i difetti di fabbricazione. La garanzia a vita ERARD è gratuita, personale e non cedibile.

Le modalità di esercizio della presente garanzia sono precisate nelle "condizioni generali di vendita" e nel "contratto garanzia-SAV" (disponibile su richiesta o consultabile al sito [www.erard.com](http://www.erard.com)).

#### Condizioni di garanzia

Per usufruire di questa garanzia, occorre contattare il servizio clienti (numero verde: +33 [0]4 72 46 16 26) ed inoltrargli una copia della fattura originale precisando la data di acquisto, il nome del rivenditore nonché il buono di garanzia indicante il tipo di prodotto e il relativo numero di serie.

Tuttavia, la garanzia decade nei seguenti casi:

- Parti soggette a normale usura, ossia: anello di spinta, asse di rotazione, copertura in plastica, cuscinetto adesivo. (Le parti soggette ad usura sono garantite per 2 anni secondo lo statuto SAV ERARD).
- Danni causati da negligenza, installazione difettosa, uso improprio o non conforme alle raccomandazioni del presente manuale (Impatti, graffi ecc...)
- Danni dovuti a cause esterne all'apparecchio: caduta del prodotto, danni causati dall'acqua, incendio, fulmini, ecc.
- Danni legati a qualsiasi modifica o riparazione effettuata da persone non autorizzate da ERARD.
- Danni legati allo stoccaggio del prodotto prima dell'installazione del prodotto stesso.
- Eventuali danni durante il trasporto, relativi all'esecuzione della presente garanzia.

#### Avvertenza

Per i supporti ERARD, le viti e i tasselli in dotazione sono adatti a muri in materiali duri e pieni (cemento, mattoni pieni...). Per gli altri materiali, utilizzare sistemi di fissaggio adeguati alla qualità della parete e al peso da sostenere.

#### Riciclaggio a fine vita

Per contribuire alla salvaguardia dell'ambiente, procedere con metodi adeguati di smaltimento e di recupero degli imballaggi.

I cartoni usati per l'imballaggio di questo prodotto possono essere riciclati o riutilizzati.

NL

Uw product van ERARD is onderworpen aan alle vereiste proeven en voldoet aan alle geldende veiligheidsvereisten. Het beschikt over een levenslange garantie tegen elke productie fout. De levenslange garantie van ERARD is gratis, persoonlijk en niet-overdraagbaar. De modaliteiten om deze garantie in te roepen, worden verduidelijkt in de "algemene verkoopvoorwaarden" en het DNV-garantieverdrag (beschikbaar op aanvraag of te raadplegen op de site [www.erard.com](http://www.erard.com)).

#### Garantievoorwaarden

Om van deze garantie gebruik te maken, dient u contact op te nemen met de klantendienst (gratis nummer: +33 (0)4 72 46 16 26) en een kopij van de originele factuur te sturen met vermelding van de aankoopdatum, de naam van de dealer en het garantieformulier met vermelding van het producttype en het serienummer.

De garantie geldt evenwel niet in de volgende gevallen:

- Onderdelen met een normale slijtvastheid, dat wil zeggen: wrijvingsring, rotatie-as, plastic afdekkingen. [Slijtvaste onderdelen hebben 2 jaar garantie in overeenstemming met het klantenservice ERARD handvest].
- Schade veroorzaakt door nalatigheid, onjuiste installatie, abnormaal gebruik of niet in overeenstemming met de aanbevelingen in deze handleiding (stoten, krassen enz.).
- Schade veroorzaakt door een externe factor: vallen van het product, waterschade, brand, blikseminslag, enz.
- Schade veroorzaakt door een wijziging of een reparatie uitgevoerd door personen die niet ERARD gemachtigd zijn.
- Schade veroorzaakt door de wijze van opslag van het product vóór de installatie.
- Eventuele schade tijdens het transport in verband met de uitvoering van deze garantie.

#### Waarschuwing

De bij de dragers van ERARD geleverde schroeven en pluggen zijn bestemd voor volle muren van een hard materiaal (beton, volle baksteen, ...). Gelieve voor de andere materialen bevestigingsystemen te gebruiken die afgestemd zijn op de kwaliteit van de muur en het te dragen gewicht.

#### Recyclage aan het einde van de levensduur

Om een bijdrage te leveren tot de bescherming van het milieu, gelieve de verpakkingen op de juiste manier te verwijderen en te recyclen.

De dozen waarin het product verpakt wordt, kunnen gerecycleerd of hergebruikt worden.

GARANTIE

PT

O seu produto ERARD foi submetido a todos os testes necessários, cumprindo com todos os requisitos de segurança aplicáveis defeito de fabrico. Tem garantia vitalícia contra qualquer . A garantia vitalícia da ERARD é gratuita, pessoal e intransferível. As modalidades de exercício da presente garantia encontram-se descritas nas "condições gerais de venda" e no "cartão de garantia pós-venda" [disponíveis mediante pedido simples ou consultáveis no website [www.erard.com](http://www.erard.com)].

#### Condições da garantia

Para beneficiar desta garantia deve contactar o serviço de assistência ao cliente (número verde +33 (0)4 72 46 16 26) e apresentar cópia da factura original especificando a data de compra e o nome do revendedor bem como o certificado de garantia onde se indica o tipo de produto e respectivo número de série.

A garantia não abrange as seguintes situações:

- as peças sujeitas a desgaste normal (listo é: anel de fricção, eixo de rotação, tampa plástica, almofada adesiva). Essas peças são garantidas por 2 anos, de acordo com o procedimento de serviço após venda da Erard
- Danos causados por negligência, instalação incorreta, mau uso ou contrário as instruções dadas neste manual. (impactos, riscos, etc ...).
- Danos ligados a uma causa não relacionada com o produto: queda, danos causados pela água, fogo, raios, etc.
- Danos relacionados com quaisquer modificações ou reparações feitas por pessoas fora da ERARD.
- Danos resultantes do armazenamento do produto antes da instalação.
- Qualquer dano de transporte que poderia constituir obstáculos à realização do objecto da garantia

#### Aviso

Os suportes ERARD, parafusos e buchas fornecidos destinam-se a paredes constituídas em materiais rígidos e planos (betão, tijolo liso...). Para os restantes materiais, utilizar sistemas de fixação adaptados à qualidade da parede e ao peso a suportar.

#### Reciclagem Em Fim De Vida

Para contribuir para a protecção do ambiente, utilizar métodos adequados de eliminação e recuperação das embalagens.

As peças utilizadas para a embalagem deste produto podem ser recicladas.

GARANTIA

# WWW.ERARD.COM



GARANTIE À VIE  
LEBENS-LANGE GARANTIE  
LIFE TIME WARRANTY

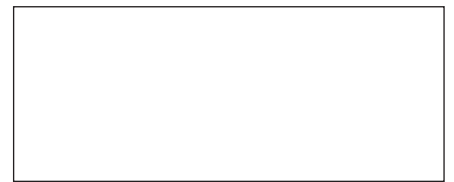

Pensez à  
donner ou  
recycler.

Association  
ou

Magasin  
ou

Déchèterie

<https://quefairede mesdechets.fr>



VOUS AVEZ BESOIN DE CONSEILS?  
YOU NEED HELP ?

**N° Vert 0 800 40 40 60**

APPEL GRATUIT DEPUIS UN POSTE FIXE

INTERNATIONAL : +33(0) 472 46 16 26

CONÇU EN FRANCE / FABRIQUÉ EN CHINE  
DESIGNED IN FRANCE / MANUFACTURED IN CHINA

ERARD - ZI de Chavanoz, 4 route de la Plaine 38236 PONT DE CHERUY cedex - FRANCE