

Coffret plastique
1x18 Modules

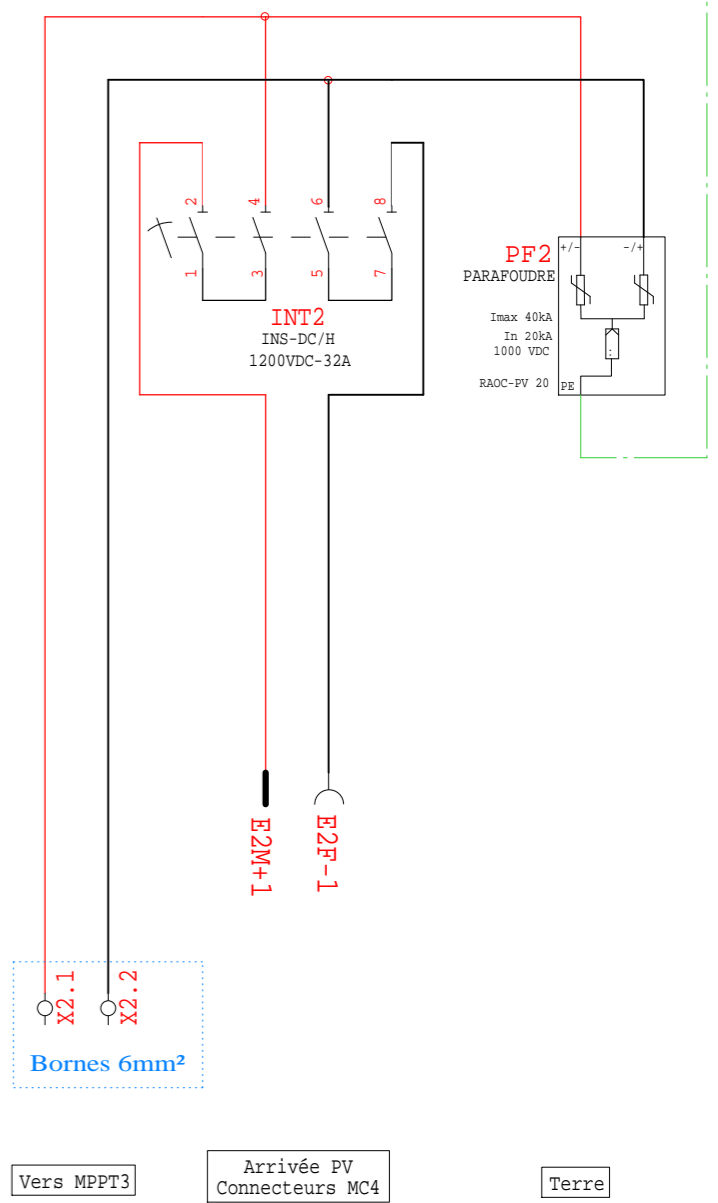

X1/PF1/INT1/INT2/PF2/X2

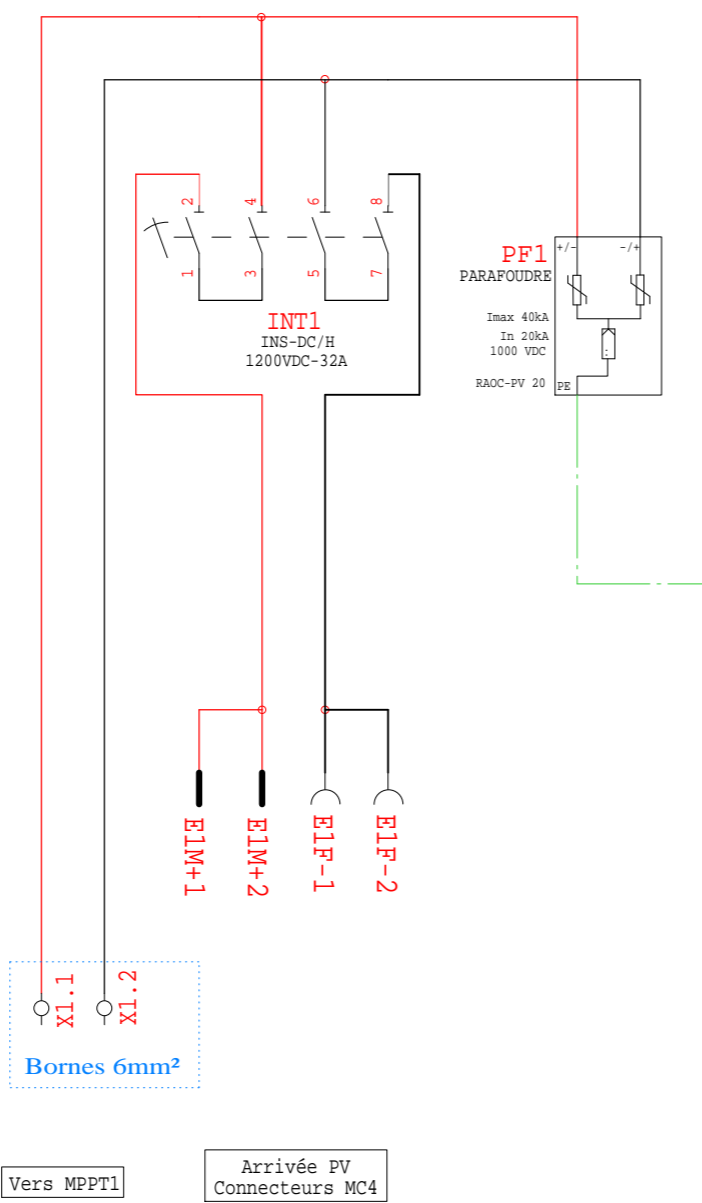
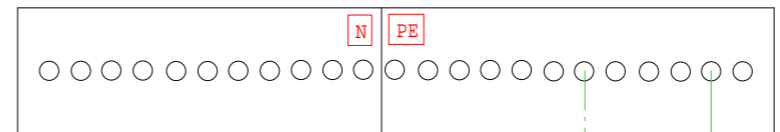
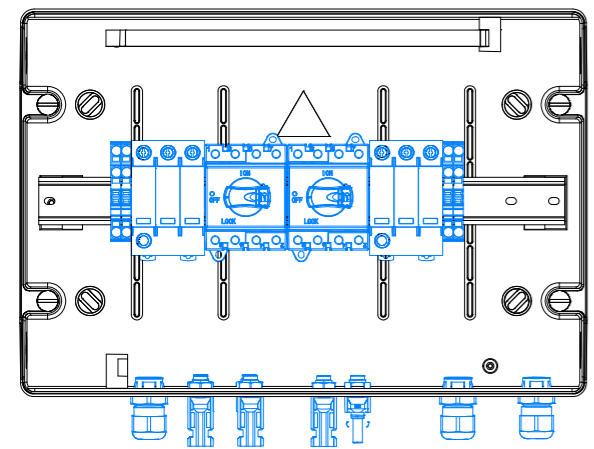

2 PE M20 Bis

2 PE M20 Bis

1 PE M20 Bis

Coffret 1x18 Modules PI65 IK07 Classe II
Etiquettes Normalisées UTE C 15 712-1
Entrées + / - Via connecteurs MC4
Sorties + / - Via 4 PE M20 Bis
Terre via 1 PE M20 Bis

