

Fiche produit

Article n° Z5.504.3321.0

Passage de câble pour vis PG29 MS 12 18,0-25,0



Article n°	Z5.504.3321.0
EAN	4049088386350
Unité de commande	10 Piece(s)





certificats/approbations

Données techniques

**général**

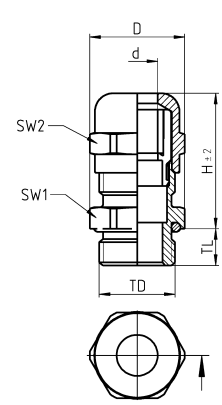
longueur du filetage	12 mm
diamètre Min. du câble	18 mm
diamètre Max. du câble	25 mm
Degré de protection (IP)	IP68
matériel	Laiton
Couleur	Autre
Résistant aux chocs	Oui
Protection du rayon de courbure / manchon d'arrondi	Aucun
Support de traversé avec serre-câble	Aucun
Type de scellement	anneau caoutchouc-/neoprene
presse étoupe détachable	Aucun
Zone multi-joint	Aucun
Type de filetage	Métrique
Sans halogène	Oui
classe d'inflammabilité des matériaux d'isolation selon la norme UL94	Autre

**Dessin technique**

<p>These drawings will be copied (unless of other type) into the drawing folder of the CAD system.</p> <p>These drawings will be copied (unless of other type) into the drawing folder of the CAD system.</p> <p>These drawings will be copied (unless of other type) into the drawing folder of the CAD system.</p>		<table border="1" style="width:100%; border-collapse: collapse;"> <thead> <tr> <th>Wieland Teilenummer part number</th> <th>Gewinde Verschraubung thread type of fitting</th> <th>Gewinde Schraubkappe thread type of cap</th> <th>Klemmbereich clamping range Ø min-max mm</th> <th>Gewinde-Ø thread-Ø TD mm</th> <th>Gewindelänge thread length TL mm</th> <th>Höhe ohne Gewindelänge height without thread H mm</th> <th>Verschraubung fitting SW1 mm</th> <th>Schraubkappe cap SW2 mm</th> <th>Äußen-Ø outer-Ø D mm max.</th> <th>Innen-Ø inner-Ø D mm max.</th> </tr> </thead> <tbody> <tr><td>Z5.504.2021.0</td><td>PG7</td><td>PG 7</td><td>3,0-6,5</td><td>12,5</td><td>6,0</td><td>22,0</td><td>14,0</td><td>14,0</td><td>15,5</td><td>Ø10,4</td></tr> <tr><td>Z5.504.2121.0</td><td>PG7</td><td>PG 7</td><td>3,0-6,5</td><td>12,5</td><td>10,0</td><td>22,0</td><td>14,0</td><td>14,0</td><td>15,5</td><td>Ø10,4</td></tr> <tr><td>Z5.504.2221.0</td><td>PG9</td><td>PG 9</td><td>4,0-8,0</td><td>15,2</td><td>6,0</td><td>23,5</td><td>17,0</td><td>17,0</td><td>18,9</td><td>Ø8,3</td></tr> <tr><td>Z5.504.2321.0</td><td>PG9</td><td>PG 9</td><td>4,0-8,0</td><td>15,2</td><td>10,0</td><td>23,5</td><td>17,0</td><td>17,0</td><td>18,9</td><td>Ø8,3</td></tr> <tr><td>Z5.504.2421.0</td><td>PG11</td><td>PG 11</td><td>5,0-10,0</td><td>18,6</td><td>6,0</td><td>26,0</td><td>20,0</td><td>20,0</td><td>22,0</td><td>Ø10,4</td></tr> <tr><td>Z5.504.2521.0</td><td>PG11</td><td>PG 11</td><td>5,0-10,0</td><td>18,6</td><td>10,0</td><td>26,0</td><td>20,0</td><td>20,0</td><td>22,0</td><td>Ø10,4</td></tr> <tr><td>Z5.504.2621.0</td><td>PG13,5</td><td>PG 13,5</td><td>6,0-12,0</td><td>20,4</td><td>6,5</td><td>24,5</td><td>22,0</td><td>22,0</td><td>24,5</td><td>Ø12,4</td></tr> <tr><td>Z5.504.2721.0</td><td>PG13,5</td><td>PG13,5</td><td>6,0-12,0</td><td>20,4</td><td>10,0</td><td>24,5</td><td>22,0</td><td>22,0</td><td>24,5</td><td>Ø12,4</td></tr> <tr><td>Z5.504.2821.0</td><td>PG16</td><td>PG 16</td><td>10,0-14,0</td><td>22,5</td><td>6,5</td><td>28,0</td><td>24,0</td><td>24,0</td><td>26,5</td><td>Ø14,4</td></tr> <tr><td>Z5.504.2921.0</td><td>PG16</td><td>PG16</td><td>10,0-14,0</td><td>22,5</td><td>10,0</td><td>28,0</td><td>24,0</td><td>24,0</td><td>26,5</td><td>Ø14,4</td></tr> <tr><td>Z5.504.3021.0</td><td>PG21</td><td>PG 21</td><td>13,0-18,0</td><td>28,3</td><td>7,2</td><td>32,5</td><td>30,0</td><td>30,0</td><td>33,0</td><td>Ø18,4</td></tr> <tr><td>Z5.504.3121.0</td><td>PG21</td><td>PG21</td><td>13,0-18,0</td><td>28,3</td><td>12,0</td><td>32,5</td><td>30,0</td><td>30,0</td><td>33,0</td><td>Ø18,4</td></tr> <tr><td>Z5.504.3221.0</td><td>PG29</td><td>PG 29</td><td>18,0-25,0</td><td>37,0</td><td>8,0</td><td>38,5</td><td>40,0</td><td>40,0</td><td>44,5</td><td>Ø25,5</td></tr> <tr><td>Z5.504.3321.0</td><td>PG29</td><td>PG29</td><td>18,0-25,0</td><td>37,0</td><td>12,0</td><td>38,5</td><td>40,0</td><td>40,0</td><td>44,5</td><td>Ø25,5</td></tr> <tr><td>Z5.504.3421.0</td><td>PG36</td><td>PG 36</td><td>22,0-32,0</td><td>47,0</td><td>9,0</td><td>48,0</td><td>50,0</td><td>50,0</td><td>55,5</td><td>Ø32,5</td></tr> <tr><td>Z5.504.3521.0</td><td>PG36</td><td>PG36</td><td>22,0-32,0</td><td>47,0</td><td>14,0</td><td>48,0</td><td>50,0</td><td>50,0</td><td>55,5</td><td>Ø32,5</td></tr> </tbody> </table>					Wieland Teilenummer part number	Gewinde Verschraubung thread type of fitting	Gewinde Schraubkappe thread type of cap	Klemmbereich clamping range Ø min-max mm	Gewinde-Ø thread-Ø TD mm	Gewindelänge thread length TL mm	Höhe ohne Gewindelänge height without thread H mm	Verschraubung fitting SW1 mm	Schraubkappe cap SW2 mm	Äußen-Ø outer-Ø D mm max.	Innen-Ø inner-Ø D mm max.	Z5.504.2021.0	PG7	PG 7	3,0-6,5	12,5	6,0	22,0	14,0	14,0	15,5	Ø10,4	Z5.504.2121.0	PG7	PG 7	3,0-6,5	12,5	10,0	22,0	14,0	14,0	15,5	Ø10,4	Z5.504.2221.0	PG9	PG 9	4,0-8,0	15,2	6,0	23,5	17,0	17,0	18,9	Ø8,3	Z5.504.2321.0	PG9	PG 9	4,0-8,0	15,2	10,0	23,5	17,0	17,0	18,9	Ø8,3	Z5.504.2421.0	PG11	PG 11	5,0-10,0	18,6	6,0	26,0	20,0	20,0	22,0	Ø10,4	Z5.504.2521.0	PG11	PG 11	5,0-10,0	18,6	10,0	26,0	20,0	20,0	22,0	Ø10,4	Z5.504.2621.0	PG13,5	PG 13,5	6,0-12,0	20,4	6,5	24,5	22,0	22,0	24,5	Ø12,4	Z5.504.2721.0	PG13,5	PG13,5	6,0-12,0	20,4	10,0	24,5	22,0	22,0	24,5	Ø12,4	Z5.504.2821.0	PG16	PG 16	10,0-14,0	22,5	6,5	28,0	24,0	24,0	26,5	Ø14,4	Z5.504.2921.0	PG16	PG16	10,0-14,0	22,5	10,0	28,0	24,0	24,0	26,5	Ø14,4	Z5.504.3021.0	PG21	PG 21	13,0-18,0	28,3	7,2	32,5	30,0	30,0	33,0	Ø18,4	Z5.504.3121.0	PG21	PG21	13,0-18,0	28,3	12,0	32,5	30,0	30,0	33,0	Ø18,4	Z5.504.3221.0	PG29	PG 29	18,0-25,0	37,0	8,0	38,5	40,0	40,0	44,5	Ø25,5	Z5.504.3321.0	PG29	PG29	18,0-25,0	37,0	12,0	38,5	40,0	40,0	44,5	Ø25,5	Z5.504.3421.0	PG36	PG 36	22,0-32,0	47,0	9,0	48,0	50,0	50,0	55,5	Ø32,5	Z5.504.3521.0	PG36	PG36	22,0-32,0	47,0	14,0	48,0	50,0	50,0	55,5	Ø32,5
Wieland Teilenummer part number	Gewinde Verschraubung thread type of fitting	Gewinde Schraubkappe thread type of cap	Klemmbereich clamping range Ø min-max mm	Gewinde-Ø thread-Ø TD mm	Gewindelänge thread length TL mm	Höhe ohne Gewindelänge height without thread H mm	Verschraubung fitting SW1 mm	Schraubkappe cap SW2 mm	Äußen-Ø outer-Ø D mm max.	Innen-Ø inner-Ø D mm max.																																																																																																																																																																																							
Z5.504.2021.0	PG7	PG 7	3,0-6,5	12,5	6,0	22,0	14,0	14,0	15,5	Ø10,4																																																																																																																																																																																							
Z5.504.2121.0	PG7	PG 7	3,0-6,5	12,5	10,0	22,0	14,0	14,0	15,5	Ø10,4																																																																																																																																																																																							
Z5.504.2221.0	PG9	PG 9	4,0-8,0	15,2	6,0	23,5	17,0	17,0	18,9	Ø8,3																																																																																																																																																																																							
Z5.504.2321.0	PG9	PG 9	4,0-8,0	15,2	10,0	23,5	17,0	17,0	18,9	Ø8,3																																																																																																																																																																																							
Z5.504.2421.0	PG11	PG 11	5,0-10,0	18,6	6,0	26,0	20,0	20,0	22,0	Ø10,4																																																																																																																																																																																							
Z5.504.2521.0	PG11	PG 11	5,0-10,0	18,6	10,0	26,0	20,0	20,0	22,0	Ø10,4																																																																																																																																																																																							
Z5.504.2621.0	PG13,5	PG 13,5	6,0-12,0	20,4	6,5	24,5	22,0	22,0	24,5	Ø12,4																																																																																																																																																																																							
Z5.504.2721.0	PG13,5	PG13,5	6,0-12,0	20,4	10,0	24,5	22,0	22,0	24,5	Ø12,4																																																																																																																																																																																							
Z5.504.2821.0	PG16	PG 16	10,0-14,0	22,5	6,5	28,0	24,0	24,0	26,5	Ø14,4																																																																																																																																																																																							
Z5.504.2921.0	PG16	PG16	10,0-14,0	22,5	10,0	28,0	24,0	24,0	26,5	Ø14,4																																																																																																																																																																																							
Z5.504.3021.0	PG21	PG 21	13,0-18,0	28,3	7,2	32,5	30,0	30,0	33,0	Ø18,4																																																																																																																																																																																							
Z5.504.3121.0	PG21	PG21	13,0-18,0	28,3	12,0	32,5	30,0	30,0	33,0	Ø18,4																																																																																																																																																																																							
Z5.504.3221.0	PG29	PG 29	18,0-25,0	37,0	8,0	38,5	40,0	40,0	44,5	Ø25,5																																																																																																																																																																																							
Z5.504.3321.0	PG29	PG29	18,0-25,0	37,0	12,0	38,5	40,0	40,0	44,5	Ø25,5																																																																																																																																																																																							
Z5.504.3421.0	PG36	PG 36	22,0-32,0	47,0	9,0	48,0	50,0	50,0	55,5	Ø32,5																																																																																																																																																																																							
Z5.504.3521.0	PG36	PG36	22,0-32,0	47,0	14,0	48,0	50,0	50,0	55,5	Ø32,5																																																																																																																																																																																							
<table border="1" style="width:100%; border-collapse: collapse;"> <tr><td>nach/according to</td><td>DIN EN 62444 / VDE 0619</td></tr> <tr><td>Gewinde gemäß/thread according to</td><td>DIN 40430</td></tr> <tr><td>Material Verschraubung/material fitting</td><td>Messing/brass PA 6 UL94-V2</td></tr> <tr><td>Material Verschraubungsdichtung/material seal of fitting</td><td>CR</td></tr> <tr><td>Material O-Ring/material O-ring</td><td>NBR</td></tr> <tr><td>Schutzklasse nach/protection class according to</td><td>DIN EN 60529 IP 66-68</td></tr> </table>		nach/according to	DIN EN 62444 / VDE 0619	Gewinde gemäß/thread according to	DIN 40430	Material Verschraubung/material fitting	Messing/brass PA 6 UL94-V2	Material Verschraubungsdichtung/material seal of fitting	CR	Material O-Ring/material O-ring	NBR	Schutzklasse nach/protection class according to	DIN EN 60529 IP 66-68	<p>frei von lackbenetzungsstörenden Substanzen (Silikonfrei)/ free from substances that prevent paint adhesion (silicon free)</p> <p>Weitere Daten siehe KATALOG oder eKatalog additional data see CATALOG or eCATALOG <a href="http://www.wieland-electric.com">www.wieland-electric.com</a> <a href="http://eshop.wieland-electric.com">eshop.wieland-electric.com</a></p>																																																																																																																																																																																			
nach/according to	DIN EN 62444 / VDE 0619																																																																																																																																																																																																
Gewinde gemäß/thread according to	DIN 40430																																																																																																																																																																																																
Material Verschraubung/material fitting	Messing/brass PA 6 UL94-V2																																																																																																																																																																																																
Material Verschraubungsdichtung/material seal of fitting	CR																																																																																																																																																																																																
Material O-Ring/material O-ring	NBR																																																																																																																																																																																																
Schutzklasse nach/protection class according to	DIN EN 60529 IP 66-68																																																																																																																																																																																																
<p>Toleranzsystem Size ISO 14005 © / Tolerance system Size ISO 14005 ©. jst/yes <input checked="" type="checkbox"/> Stoffverbot- und Deklarationsliste nach WN 5000 010 ist anzuhalten (This ISO-standard describes the envelope principle. According to the envelope principle (conformity with Wieland document WN 5000 010 a list of prohibited / prohibit the deviations of form and parallelism are limited by the size tolerances) (electronic hazardous substances) to be declared)</p> <p>Freitoleranz nach General tolerance <input checked="" type="checkbox"/> Z- Zeichnung, keine manuellen Änderungen <input type="checkbox"/> Verwendung <input type="checkbox"/> Blatt: 1 von 1 ISO - drawing, no manual modifications allowed first use Sheet: 1 of 1</p>		<table border="1" style="width:100%; border-collapse: collapse;"> <tr> <td>Werkstoff / Material</td> <td>Tag/Date</td> <td>Name</td> <td>Zeichnung Nr. / Drawing No.</td> <td>Index</td> </tr> <tr> <td>2.1</td> <td>31.05.2017</td> <td>SchmH</td> <td>T Z5.504.2021.0 13K</td> <td>-</td> </tr> <tr> <td colspan="5" style="text-align: right;">Maße in mm / Dimensions are in mm</td> </tr> <tr> <td colspan="5" style="text-align: center;">  <b>KABELVERSCHRAUBUNG</b>  PG, Metall  PG, metal </td> </tr> </table>					Werkstoff / Material	Tag/Date	Name	Zeichnung Nr. / Drawing No.	Index	2.1	31.05.2017	SchmH	T Z5.504.2021.0 13K	-	Maße in mm / Dimensions are in mm					 <b>KABELVERSCHRAUBUNG</b> PG, Metall PG, metal																																																																																																																																																																											
Werkstoff / Material	Tag/Date	Name	Zeichnung Nr. / Drawing No.	Index																																																																																																																																																																																													
2.1	31.05.2017	SchmH	T Z5.504.2021.0 13K	-																																																																																																																																																																																													
Maße in mm / Dimensions are in mm																																																																																																																																																																																																	
 <b>KABELVERSCHRAUBUNG</b> PG, Metall PG, metal																																																																																																																																																																																																	
<p>Schnitt_Z5_5p4_2021_0_13K-AA-001_sheet_L2 CADW4032 /Schnitt 2017-05-31T11:00:50 1.000</p>		<p>6 QU-MEE-07/14 a</p>																																																																																																																																																																																															