

Communications

CODESYS V2 – CODESYS V3

Allen Bradley SLC/MicroLogix – Allen Bradley Logix

Modbus – ELC

Simatic S7 – Simatic S7/200 PPI

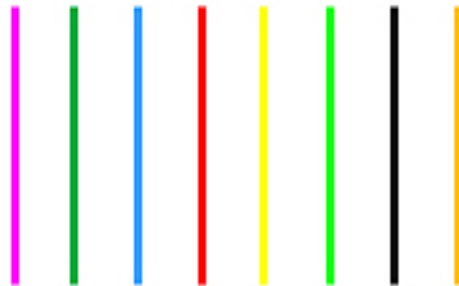

Powering Business Worldwide

## Imprint

### Manufacturer

Eaton Automation GmbH  
Spinnereistrasse 8-14  
CH-9008 St. Gallen  
Switzerland  
[www.eaton.eu](http://www.eaton.eu)  
[www.eaton.com](http://www.eaton.com)

### Support

**Region North America**  
Eaton Corporation  
Electrical Sector  
1111 Superior Ave.  
Cleveland, OH 44114  
United States  
877-ETN-CARE (877-386-2273)  
[www.eaton.com](http://www.eaton.com)

### Other regions

Please contact your local distributor or send an e-mail to:  
[automation@eaton.com](mailto:automation@eaton.com)

### Original instructions

English

### Redaction

Manfred Hüppi

### Brand and product names

All brand and product names are trademarks or registered trademarks of the owner concerned.

### Copyright

© Eaton Automation GmbH, CH-9008 St. Gallen

All rights, including those of translation, reserved.

None of this documents may be reproduced or processed, duplicated or distributed by electronic systems in any form (print, photocopy, microfilm or any other process) without the written permission of Eaton Automation GmbH, St. Gallen.

Subject to alterations

## Imprint

<b>1</b>	<b>General</b> .....	<b>7</b>
1.1	Purpose of this user manual .....	7
1.2	Providing feedback on this user manual .....	7
1.3	Additional documentation .....	7
<b>2</b>	<b>Overview of CODESYS V2 Communication</b> .....	<b>8</b>
2.1	Function principle .....	8
2.1.1	Communication via Ethernet .....	8
2.1.2	Connection test .....	9
<b>3</b>	<b>Overview of CODESYS V3 Communication</b> .....	<b>11</b>
3.1	Function principle .....	11
3.2	Communication parameters .....	12
3.2.1	Supported systems .....	12
3.3	Supported data.....	12
3.3.1	Addresses .....	12
3.3.2	Variable type .....	12
3.3.3	Data Type.....	13
3.3.4	Structs .....	13
3.4	Fieldbus.....	14
<b>4</b>	<b>Overview of Allen Bradley SLC / MicroLogix communication</b> .....	<b>15</b>
4.1	Function principle .....	15
4.1.1	Communication via Ethernet .....	15
4.1.2	Serial communications .....	16
4.2	Communication parameters .....	16
4.2.1	Supported systems .....	16
4.3	Communication parameters (serial communication) .....	17
4.3.1	Supported data.....	17
<b>5</b>	<b>Overview of Allen Bradley Logix communication</b> .....	<b>21</b>
5.1	Function principle .....	21
5.1.1	Communication via Ethernet .....	21
5.2	Communication parameters .....	22
5.2.1	Supported systems .....	22
<b>6</b>	<b>Overview of Modbus communication</b> .....	<b>23</b>
6.1	Function principle .....	23
6.2	Communication parameters .....	24
6.2.1	Supported data types .....	24
6.3	Supported data.....	24
6.3.1	Addresses .....	24
6.3.2	Data interpreter .....	25
6.4	Cable assembly and termination.....	26
6.4.1	SYSTEM PORT and PC COM(x) method .....	26
<b>7</b>	<b>Overview of ELC (Eaton Logic Controller) communication</b> .....	<b>27</b>

7.1	Function principle .....	27
7.2	Communication parameters .....	28
7.2.1	Supported systems .....	28
7.3	Supported data .....	29
7.3.1	Addresses .....	29
7.4	Cable assembly and termination .....	29
<b>8</b>	<b>Overview of SIMATIC S7 communication .....</b>	<b>31</b>
8.1	Function principle .....	31
8.1.1	Panel on MPI/PROFIBUS-DP network .....	31
8.1.2	Panel on Industrial Ethernet network .....	32
8.2	Communication parameters .....	33
8.2.1	Addresses .....	33
8.2.2	Memory Alignment .....	35
8.2.3	Status Refresh .....	35
8.2.4	Default Slot .....	35
<b>9</b>	<b>Overview of SIMATIC S7 / 200 PPI communication .....</b>	<b>37</b>
9.1	Function principle .....	37
9.1.1	Panel on PROFIBUS network .....	37
9.2	Communication parameters .....	38
9.2.1	Addresses .....	38
9.2.2	Strings .....	40
9.2.3	Memory Alignment .....	41
<b>10</b>	<b>Hardware .....</b>	<b>42</b>
<b>11</b>	<b>Licensing .....</b>	<b>43</b>
11.1	General .....	43
11.1.1	License Administrator .....	43
11.1.2	How to add license points .....	44
11.1.3	Overview showing the license points required for various functionalities .....	45
<b>12</b>	<b>Setting up PLC communication with Galileo .....</b>	<b>46</b>
12.1	CODESYS V2 .....	46
12.1.1	Select Communication .....	46
12.1.2	Configuring PLC parameters .....	46
12.1.3	Assigning addresses to PLC tags .....	47
12.1.4	Creating a test screen .....	48
12.1.5	Testing a Galileo project .....	49
12.1.6	General information on CODESYS V2 .....	50
12.1.7	ELAU .....	50
12.1.8	Turck .....	52
12.2	CODESYS V3 .....	53
12.2.1	Setting up communication .....	53
12.2.2	Workarounds .....	55
12.2.3	Communication with local runtime system dropping out .....	55
12.3	Allen Bradley SLC / MicroLogix .....	57
12.3.1	Setting up communication – serial interface .....	57
12.3.2	Setting up communication – Ethernet interface .....	58
12.3.3	Assigning addresses to tags .....	59

- 12.3.4 Fault messages .....59
- 12.4 Allen Bradley Logix .....62
  - 12.4.1 Setting up communication .....62
- 12.5 Allen Bradley Logix – DF1 .....64
  - 12.5.1 Setting up communication .....64
- 12.6 Modbus .....66
  - 12.6.1 Setting up communication .....66
  - 12.6.2 Assigning addresses to tags .....69
  - 12.6.3 Creating a test screen .....71
  - 12.6.4 Test Project .....72
- 12.7 Wago I/O System .....75
  - 12.7.1 Function principle .....75
  - 12.7.2 Cable assembly and termination .....75
  - 12.7.3 Setting up communication .....76
  - 12.7.4 Addressing .....77
  - 12.7.5 Fault messages .....77
- 12.8 ELC .....78
  - 12.8.1 Setting up communication – ASCII .....78
  - 12.8.2 Setting up communication – RTU .....79
  - 12.8.3 Setting up communication – TCP .....81
  - 12.8.4 Assigning addresses to tags .....82
- 12.9 Simatic S7 .....83
  - 12.9.1 Setting up communication – Siemens MPI .....83
  - 12.9.2 Setting up communication – Siemens Industrial Ethernet .....85
  - 12.9.3 Startup Delay .....85
  - 12.9.4 MPI/PROFIBUS Station No. ....86
  - 12.9.5 MPI/PROFIBUS S7-Subnet-ID .....88
  - 12.9.6 IP Address .....88
- 12.10 Siemens – S7 Profibus Standard Profile .....90
  - 12.10.1 General .....90
  - 12.10.2 Hardware requirements .....90
  - 12.10.3 SIMATIC network settings .....90
  - 12.10.4 Setting up communication – Siemens S7 Profibus Standard Profile .....91
  - 12.10.5 Fault messages .....92
  - 12.10.6 Bug Fix .....93
- 12.11 SIMATIC S7 / 200 PPI .....94
  - 12.11.1 Setting up communication – SIMATIC S7 / 200 PPI .....94
  - 12.11.2 Fault messages .....95
  - 12.11.3 Bug Fix .....95
  
- 13 Fault messages .....97**

Imprint

## 1 General

### 1.1 Purpose of this user manual

This user manual contains the information needed in order to connect Eaton Automation automation components to Galileo communications.

This user manual goes over the necessary installation and configuration steps. It does not, however, go over the corresponding operating system or application software.

### 1.2 Providing feedback on this user manual

If you have any comments, recommendations, or suggestions regarding this user manual, please send them to [automation@eaton.com](mailto:automation@eaton.com).

### 1.3 Additional documentation

The following documents may also come in handy.

The following documents may be helpful in the use of the device in addition to this document. These can be downloaded from our home page ([www.eaton.eu](http://www.eaton.eu)):

- [1] MN05010007Z  
System description Windows CE
- [2] MN05010009Z  
System Description – Networks in Brief
- [3] MN05003003E  
Eaton Logic Controller – Programming Manual
- [4] MN05003006E  
Eaton Logic Controller – Operation Manual
- [5] AP048003EN  
Product Application – Galileo Training: ELC Driver and Tag Import
- [6] MN04802060Z  
SIMATIC S7 PG Router User Manual

## 2 Overview of CODESYS V2 Communication

### 2.1 Function principle

The CODESYS V2 programming tool generates a symbol file that needs to be transferred to the PLC being used.

When it starts, GRS will read this symbol file from the PLC and use it to assign symbolic addresses to the tags in the PLC.

It is important to make sure that the tags in the PLC and in Galileo are declared with the same address and that their data types match. Moreover, structures and arrays must have the exact same structure.

Addresses are assigned (syntax) based on standard IEC 61131-3, and all common data types are supported, e.g.:

```
<tag>  
<tag>.<arrayindex>[]  
<struct>.<tag>  
<struct>.<tag>.<arrayindex>[]  
<prog>.<tag>  
<prog>.<tag>.<arrayindex>[]  
<prog>.<struct>.<tag>  
<prog>.<struct>.<tag>.<arrayindex>[]
```

**Note:**

It is no longer necessary to output field components for arrays in the PLC project's symbol configuration. Outputting the group entries is sufficient. This can reduce the symbol file's size significantly, resulting in faster data synchronization and more efficient space usage.

#### 2.1.1 Communication via Ethernet

To ensure efficient commissioning, you will need to set up a small network as illustrated in the following diagram:

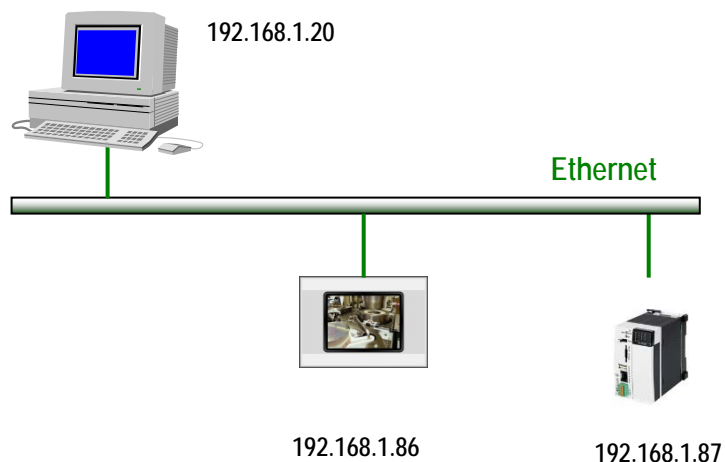



## 2 Overview of CODESYS V2 Communication

### 2.1 Function principle

Note: The IP addresses used here are only an example! What is important is for each individual device to be assigned its own unique IP address.

The following software must already be installed on your computer, and you must be familiar with its use:

- CODESYS V2 PLC programming software
- Galileo HMI visualization software

For information on the required IP address and subnet mask settings, please refer to the documentation for PLC you are using.

#### 2.1.2

#### Connection test

Use the "PING.EXE" command prompt command to make sure that every network node can be reached.

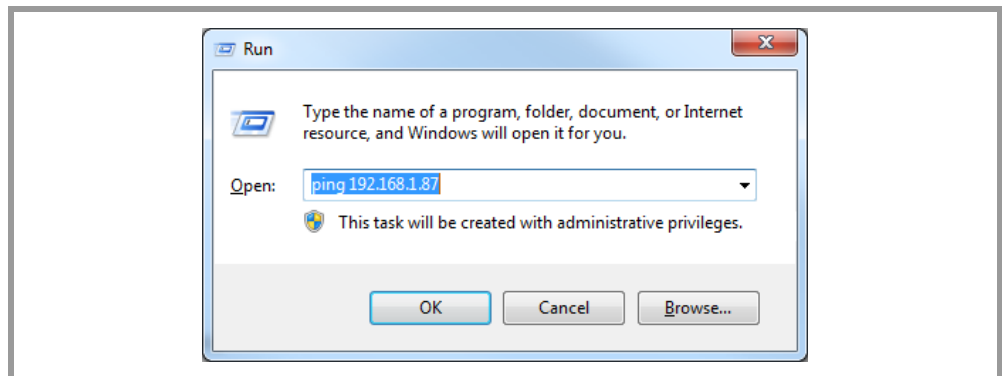

Fig. 1 Pinging an address

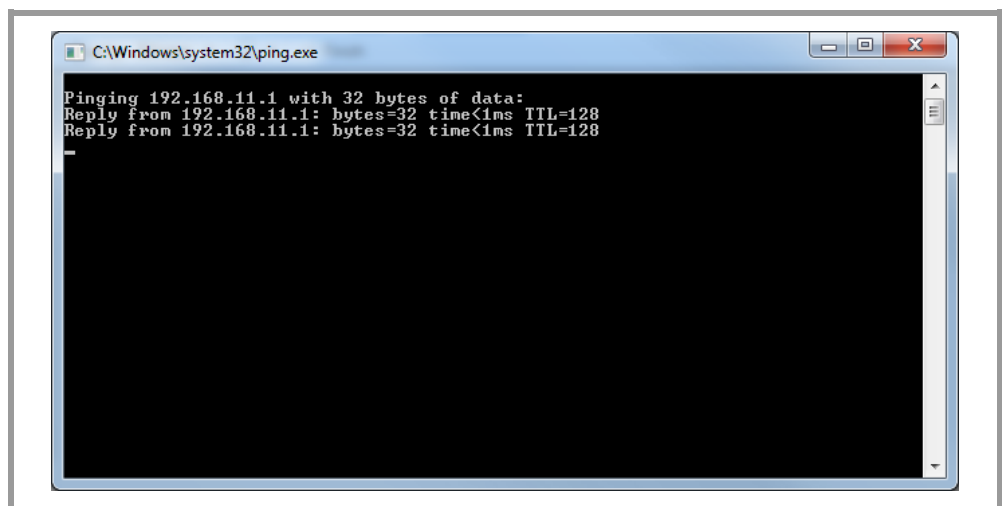

Fig. 2 Ping dialog box

## 2 Overview of CODESYS V2 Communication

### 2.1 Function principle

If the connection is working properly, the PLC and the HMI will respond as shown in the screenshot above, but with the actual IP address being used.

### 3 Overview of CODESYS V3 Communication

#### 3.1 Function principle

Multiple clients can address the communication server used in a CODESYS V3 runtime system. The CODESYS V3 runtime system is preferentially identified using the corresponding node name, although connections can also be set up using the relevant IP address. The aforementioned node name can be viewed and changed using the CODESYS V3 configuration software. It is important to note that the server can be connected to any CODESYS V3 network hierarchy level, as this will have no impact on its proper operation.

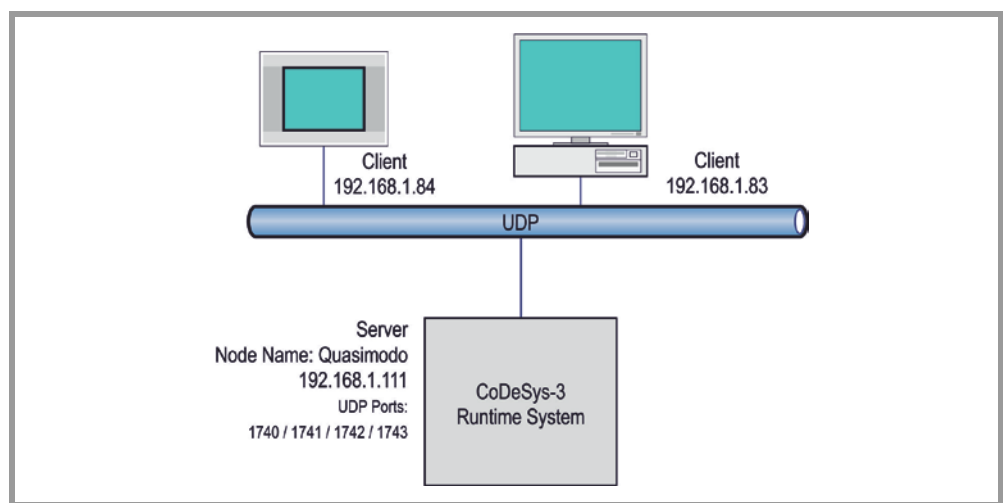

Fig. 3 How it works without a CODESYS V3 router

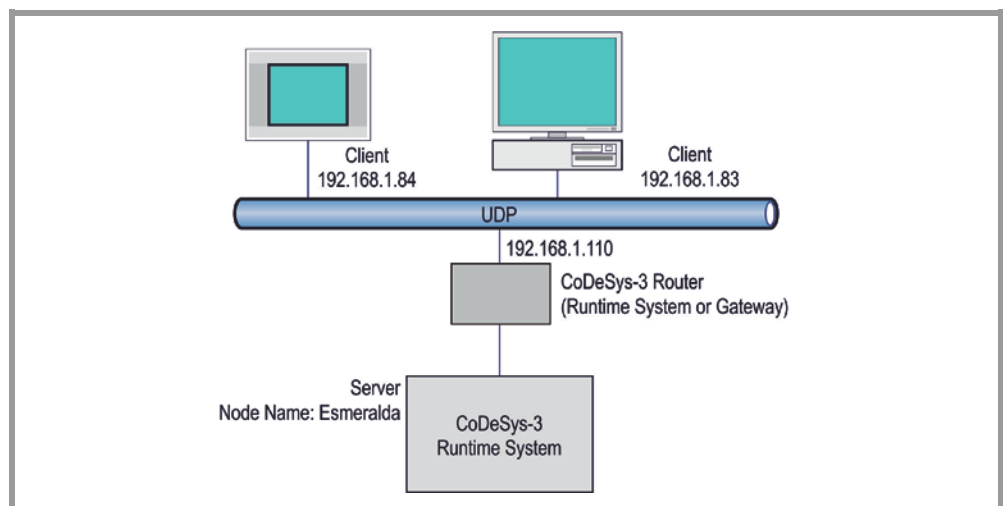

Fig. 4 How it works with a CODESYS V3 router

## 3.2 Communication parameters

### 3.2.1 Supported systems

#### 3.2.1.1 Client

The following devices can communicate with a "CODESYS V3" runtime system:

- PC with GALILEO Open and an Ethernet port
- XV series panels (exceptions: XVC100, XVC600)

Starting here, the term "client" will be used in order to refer to these devices and the software running on them.

#### 3.2.1.2 Server:

As of this writing, the following runtime systems are NOT supported:

- Bosch Rexroth CODESYS V3
- CODESYS V3 with big-endian byte order (=Motorola)

As of this writing, the following runtime systems are supported:

- CODESYS Control RTE Version 3.5.5 and higher
- CODESYS Control Win Version 3.3 and higher

Starting here, the term "CODESYS V3" will be used in order to refer to these devices and the software running on them.

## 3.3 Supported data

### 3.3.1 Addresses

Addresses can be assigned to tags at all levels within an application.

Set up the addresses on the "CODESYS V3" and the client, keeping in mind that the addresses are case-sensitive and must match.

### 3.3.2 Variable type

Declare the tags on the "CODESYS V3" using a supported tag type:

- VAR [ RETAIN | PERSISTENT ]
- VAR\_GLOBAL [ RETAIN | PERSISTENT ]
- VAR\_INPUT
- VAR\_OUTPUT

### 3.3.3

#### Data Type

Declare the tags on the "CODESYS V3" using a supported data type:

Data Type	Comment
BOOL	–
SINT	–
USINT, BYTE	The communication server does not distinguish between USINT and BYTE.
INT	–
UINT, WORD	The communication server does not distinguish between UINT and WORD.
DINT	–
UDINT, DWORD	The communication server does not distinguish between UDINT and DWORD.
REAL	–
STRING	–
WSTRING	–
TIME	TIME is mapped to DWORD on the client.
DATE	DATE is mapped to DWORD on the client.
TIME_OF_DAY	TIME_OF_DAY is mapped to DWORD on the client.
DATE_AND_TIME	DATE_AND_TIME is mapped to DWORD on the client.
Enumerated types	Keep the enumeration's underlying data type in mind (default: INT). If a value that is not defined in the enumerated type is written, it will not be captured.

Tab. 1 Supported data types



The following primitive data types are not supported as of this writing:

- LREAL
- LINT
- ULINT
- LWORD
- LTIME

### 3.3.4

#### Structs

Structures are read element by element. The structures on the "CODESYS V3" can also contain tags with unsupported data types, provided these tags are not used by any of the clients.

#### 3.4

#### Fieldbus

The client features an Ethernet port that can be used to connect it to the Ethernet network.

If the "CODESYS V3" also features an Ethernet port, it can be connected directly to the Ethernet network.

If the "CODESYS V3" does not feature an Ethernet port, a CODESYS V3 router (runtime system or gateway) must be used.

Please note: Differently configured subnet masks within a network segment can result in a client not being able to establish a connection to the CODESYS V3 runtime system.

Limitation: The client can only be run at the highest level of the CODESYS V3 network hierarchy.

## 4 Overview of Allen Bradley SLC / MicroLogix communication

### 4.1 Function principle

## 4 Overview of Allen Bradley SLC / MicroLogix communication

Both the "client" and the "controller" feature an RS232 interface that can be used to connect them. In addition, MicroLogix controllers can be optionally connected via Ethernet. For information on installation, wiring, and commissioning, please refer to the operator manuals for the devices.

### 4.1 Function principle

#### 4.1.1 Communication via Ethernet

This communication method uses the EtherNet/IP protocol via the Ethernet port. Communication takes place between a panel, or a PC, and exactly one "controller" via Ethernet.

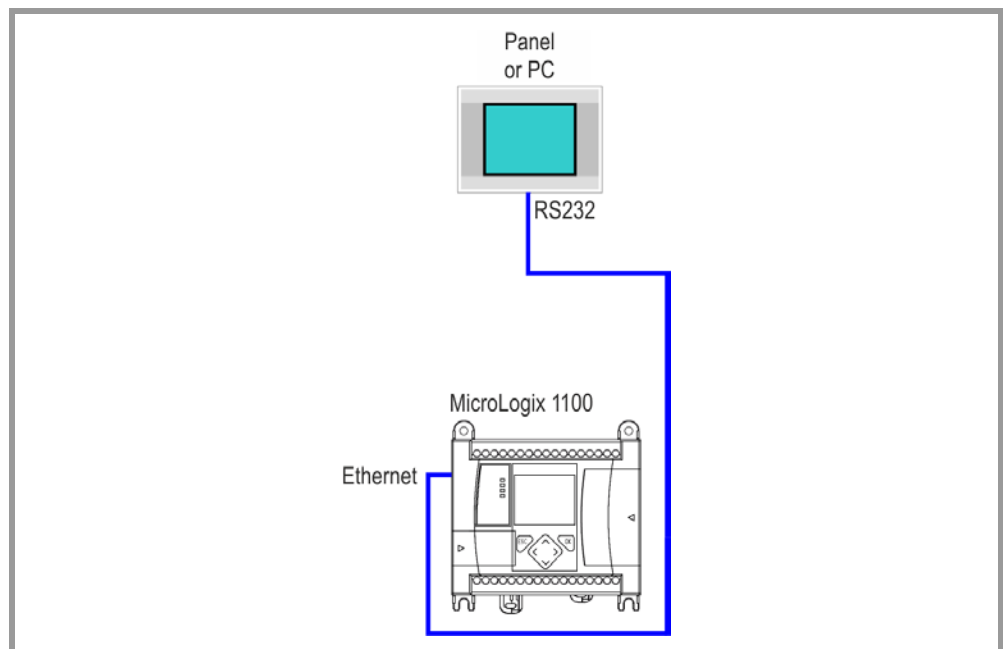

Fig. 5 How Ethernet communication works

## 4 Overview of Allen Bradley SLC / MicroLogix communication

### 4.2 Communication parameters

#### 4.1.2

#### Serial communications

This communication method uses the DF1 protocol via the RS232 interface. Communication takes place between a panel, or a PC, and exactly one "controller" via RS232.

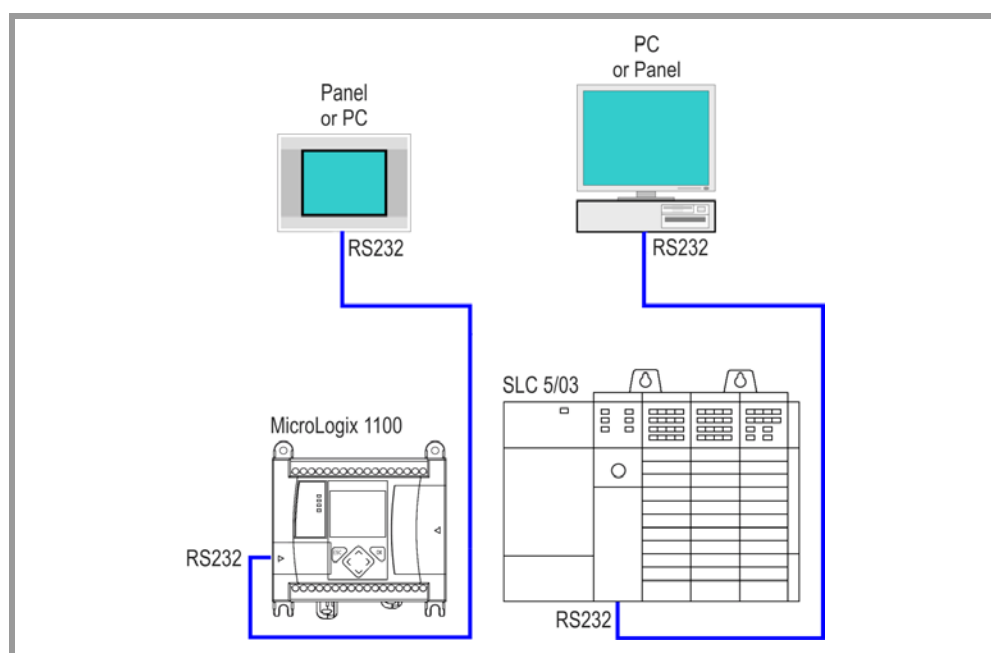

Fig. 6 How serial communication works

## 4.2

### Communication parameters

#### 4.2.1

#### Supported systems

#### 4.2.1.1

#### Client

The following devices can communicate with Communications:

- PC with GALILEO Open and RS232 interface
- XV series panel with RS232 interface
- M series panel with RS232 interface

Starting here, the term "client" will be used in order to refer to these devices and the software running on them.



## 4 Overview of Allen Bradley SLC / MicroLogix communication

### 4.3 Communication parameters (serial communication)

#### 4.2.1.2

#### Server:

The following "controllers" are supported:

- SLC 5/03 (RS232 interface)
- SLC 5/04 (RS232 interface)
- SLC 5/05 (RS232 interface)
- MicroLogix (RS232 port and Ethernet interface)

Starting here, the term "controller" will be used in order to refer to these devices.

#### 4.3

#### Communication parameters (serial communication)

The baud rate settings for the "client" and the "controller" must be identical.

The "client" uses node address 0.

Configure the Ethernet interface for the "controller" as follows:

- Node address: 1
- System Mode
- DF1 Full Duplex
- 8 Data Bits, Even Parity, 1 Stop Bit
- No Handshaking
- BCC or CRC Error Detection
- 1000 ms ACK Timeout
- 3 NAK Retries
- 3 ENQ Retries

#### 4.3.1

#### Supported data

#### 4.3.1.1

#### Addresses

designation	Address range
B-File	B0:0 ... B255:255
N-File	N0:0 ... N255:255
F-File	F0:0 ... F255:255

Tab. 2 Supported addresses

In addition to the files listed above, timer and counter scans are also supported for Ethernet communication.

## 4 Overview of Allen Bradley SLC / MicroLogix communication

### 4.3 Communication parameters (serial communication)

The available address ranges are as follows:

designation	Address range
T-File	T0:0 ... T255:255
C-File	C0:0 ... C255:255

Tab. 3 Supported addresses

#### 4.3.1.2

#### Timer

The timer consists of three word data blocks.

Word	Bit			
	0 ... 12	13	14	15
0	Used internally DN only		TT	EN
1	Default value			
2	Accumulated value			

Tab. 4 DN = Timer Date Bit  
 TT = Timer Timing Bit  
 EN = Timer Enable Bit

## 4 Overview of Allen Bradley SLC / MicroLogix communication

### 4.3 Communication parameters (serial communication)

A value array with 3 elements needs to be created in order to make the entire data block accessible on the HMI.

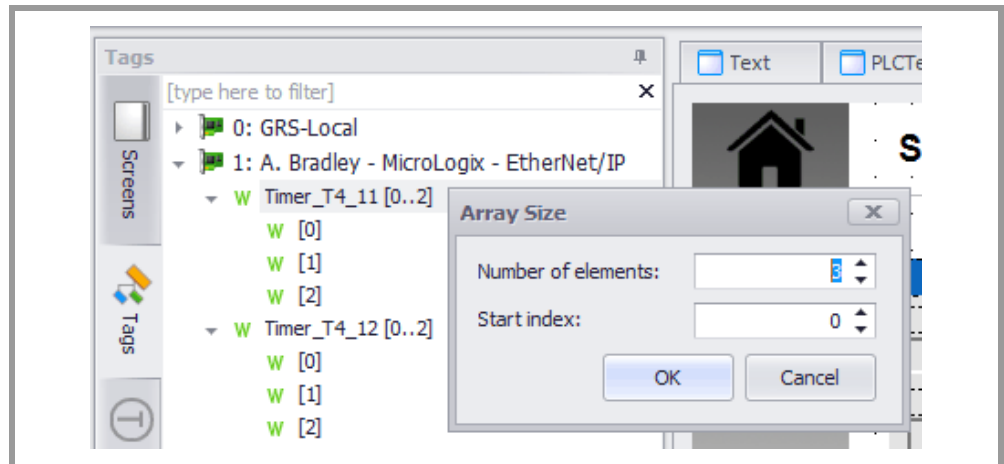

Fig. 7 Timer Array

The data block's start address is specified as usual.

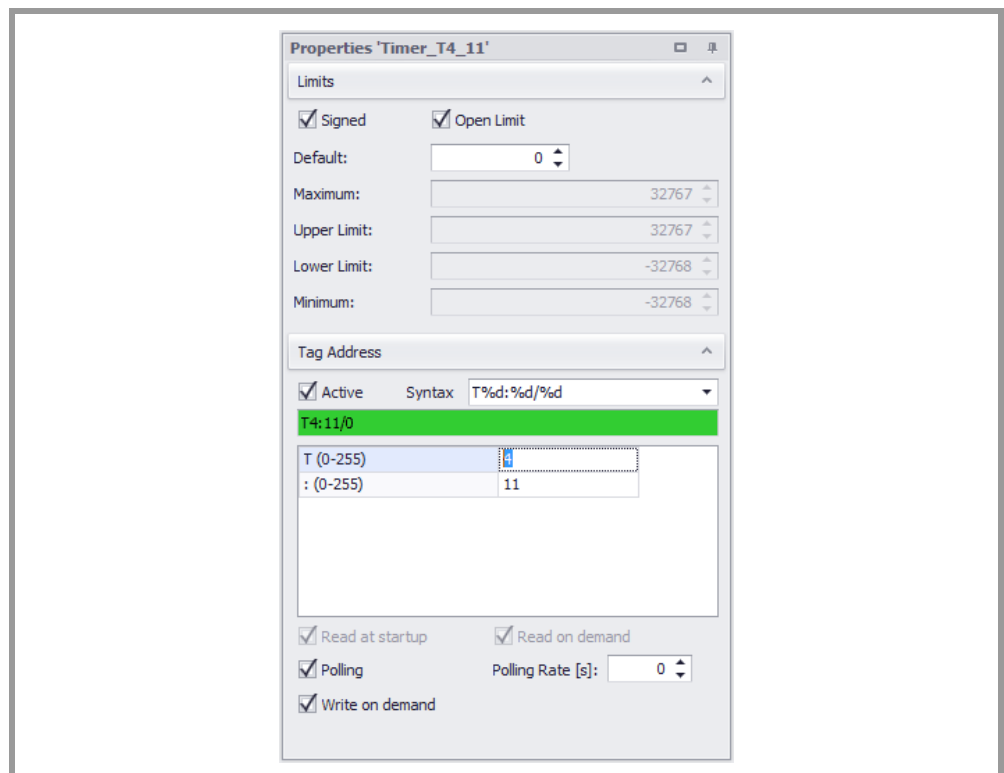

Fig. 8 Setting the address

## 4 Overview of Allen Bradley SLC / MicroLogix communication

### 4.3 Communication parameters (serial communication)

#### 4.3.1.3

#### Counter

The counter consists of three word data blocks.

Word	Bit					
	0 ... 8	11	12	13	14	15
0	Not Used	UN	OV	DN	CD	CU
1	Preset value					
2	Accumulated value					

Tab. 5 UN = Count Underflow Bit  
OV = Count Overflow Bit  
DN = Count Done Bit  
CD = Count Down Enable Bit  
CU = Count Up Enable Bit

To create counter tags, follow the same steps described for the timer in 2.4.2.

## 5 Overview of Allen Bradley Logix communication

### 5.1 Function principle

The following software must already be installed, and you must be familiar with its use:

- Galileo HMI visualization software
- RS Logix5000 programming tool

This documentation goes over the following communication options:

- A. Bradley - Logix – EtherNet/IP with Ethernet port.
- A. Bradley - Logix – DF1 with RS232 interface.

#### 5.1.1 Communication via Ethernet

The connection to the Allen Bradley Logix is made directly using the CPU's or Ethernet Communication Interface's Ethernet port.

In this regard, no additional parameters need to be configured and no function blocks need to be enabled.

The panel can communicate with multiple nodes (Allen Bradley Logix) simultaneously.

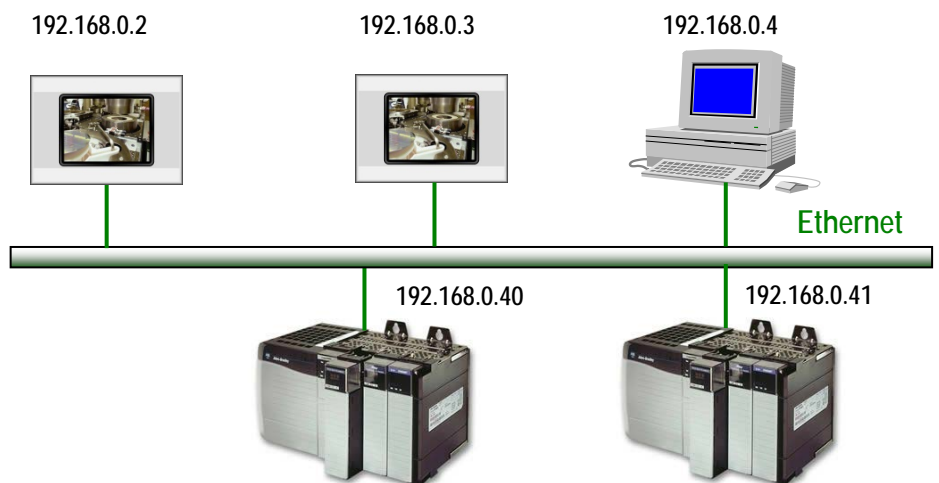

The station and IP addresses shown above are examples. What is important is for each individual node to be assigned its own unique station and/or IP address.

## 5.2 Communication parameters

### 5.2.1 Supported systems

#### 5.2.1.1 Data Types

Galileo data types are mapped to Logix as follows:

Logix	Galileo
BOOL	BIT
BIT in integer data types	BIT `/' notation
SINT	BYTE, signed
	BYTE, unsigned
INT	WORD, signed
	WORD, unsigned
DINT	DWORD, signed
	DWORD, unsigned
REAL	FLOAT
STRING	STRING

**Note:**

Only the predefined Logix STRING data type with a length of 82 characters is supported. A size of 82 bytes must be defined for a STRING in Galileo. In Logix, this will correspond to 86 bytes (4-byte length information and 82 characters).

#### 5.2.1.2 Addresses

Addresses are assigned using Allen Bradley syntax conventions.

Address syntax:

```

<tag>
<tag>.<arrayindex>[]
<struct>.<tag>
<struct>.<tag>.<arrayindex>[]
<prog>.<tag>
<prog>.<tag>.<arrayindex>[]
<prog>.<struct>.<tag>
<prog>.<struct>.<tag>.<arrayindex>[]
<struct>/<arrayindex>
<prog>.<struct>/<arrayindex>

```

Bit addressing in integer data types  
~~Bit~~ addressing in integer data types

## 6 Overview of Modbus communication

### 6.1 Function principle

This documentation describes the connection between a panel and any PLC that supports a Modbus protocol (ASCII, RTU, TCP).

When using this communication method, the panel will be the master and the PLC will be a slave. Communication will always be initiated by the panel, and the PLC will respond as appropriate for the corresponding request.

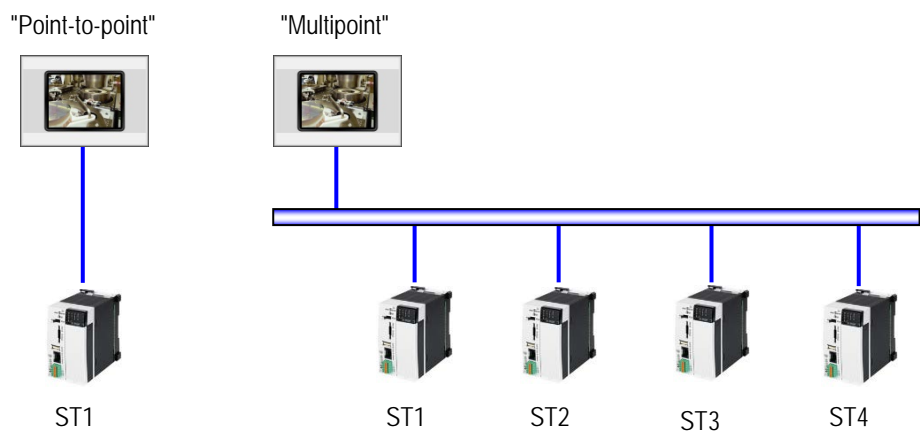

Modbus protocols use station addresses (STx). Accordingly, both "point-to-point" and "multipoint" connections can be implemented when using the appropriate physical interface (see the figure above).

**Note:**

The Modbus protocol is also available for the panel's SYSTEM PORT. This port is an RS232 interface that is not galvanically isolated.

There is also the option of connecting to a standard PC via COM(x) and implementing communication with GALILEOOPEN (GALILEO Runtime System for PC).

## 6 Overview of Modbus communication

### 6.2 Communication parameters

## 6.2 Communication parameters

### 6.2.1 Supported data types

All configurable data types from GALILEO are supported.

## 6.3 Supported data

### 6.3.1 Addresses

As per the protocol, function codes used to access various data storage areas are defined.

For Modbus RTU communication, the panels support the function codes listed below / the corresponding data storage areas.

Modbus register	GALILEO	Function code		Data type	Granularity
		Read	Write		
Coils	M	0x01	0x0F	Bit	1-bits
Input Discrets	WE	0x02	-	Bit	1-bits
Input Registers	RI	0x04	-	Word	16-bits
Registers	R	0x03	0x10	Word	16-bits

GALILEO		Modbus		PLC		Modbus		GALILEO
M	→	0x0F	→	Bit (read/write)	→	0x01	→	M
WE				Bit (read only)	→	0x02	→	WE
RI				Wort (read only)	→	0x04	→	RI
R	→	0x10	→	Wort (read/write)	→	0x03	→	R

**Note:**

For information on where the data is ultimately referenced in the PLC, please refer to the documentation for the PLC.



## 6 Overview of Modbus communication

### 6.3 Supported data

#### 6.3.2

#### Data interpreter

According to the original Modbus specification, data fields in the Modbus protocol should be interpreted using the big-endian format. However, many devices in the field do not interpret data this way, which is why there is the option to use other modes as necessary. The corresponding parameter can be configured in "PLC Selection and Configuration."

The following table shows the effect that the various modes have on the data stream based on the data type being used.

Data byte	GALILEO	Little Endian	Big Endian	Little Endian Twisted	BigEndian Twisted
00	Byte A	Byte A	Byte A	Byte B	Byte B
01	Byte B	Byte B	Byte B	Byte A	Byte A
02	DWord	DWord[0] LSB	DWord[3] MSB	DWord[1]	DWord[2]
03		DWord[1]	DWord[2]	DWord[0] LSB	DWord[3] MSB
04		DWord[2]	DWord[1]	DWord[3] MSB	DWord[0] LSB
05		DWord[3] MSB	DWord[0] LSB	DWord[2]	DWord[1]
06	Word	Word LSB	Word MSB	Word MSB	Word LSB
07		Word MSB	Word LSB	Word LSB	Word MSB
08	Byte C	Byte C	Byte C	Byte D	Byte D
09	Byte D	Byte D	Byte D	Byte C	Byte C
10	Bit[32]	Bit 0..7	Bit 0..7	Bit 8..15	Bit 8..15
11		Bit 8..15	Bit 8..15	Bit 0..7	Bit 0..7
12		Bit 16..23	Bit 16..23	Bit 24...31	Bit 24...31
13		Bit 24...31	Bit 24...31	Bit 16..23	Bit 16..23
14	CharArray[6] (String)	CharArray[0]	CharArray[0]	CharArray[1]	CharArray[1]
15		CharArray[1]	CharArray[1]	CharArray[0]	CharArray[0]
16		CharArray[2]	CharArray[2]	CharArray[3]	CharArray[3]
17		CharArray[3]	CharArray[3]	CharArray[2]	CharArray[2]
18		CharArray[4]	CharArray[4]	CharArray[5]	CharArray[5]
19		CharArray[5]	CharArray[5]	CharArray[4]	CharArray[4]

**Note:**  
As per the specification, a Modbus register always contains 16-bit values. Accordingly, a 32-bit value (double word or float) will take up 2 registers.

## 6 Overview of Modbus communication

### 6.4 Cable assembly and termination

#### 6.4 Cable assembly and termination

For general information on cable assembly and termination, lengths, and shielding, please refer to the additional documentation specified in the "General" section.

##### 6.4.1 SYSTEM PORT and PC COM(x) method



MICRO PANEL SYSTEM PORT		RS232	Various	
PIN	SIG		SIG	PIN
2	RxD		TxD	3
3	TxD		RxD	2
5	0V		0V	5
CASE	SHIELD		SHIELD	CASE

PC COM(x)		RS232	Various	
PIN	SIG		SIG	PIN
2	RxD		TxD	3
3	TxD		RxD	2
5	0V		0V	5
CASE	SHIELD		SHIELD	CASE

The port on the panel is **not** galvanically isolated, and the port on most computers will not be galvanically isolated either. Use a cable that matches the figure or a standard null modem cable.

## 7 Overview of ELC (Eaton Logic Controller) communication

### 7.1 Function principle

## 7 Overview of ELC (Eaton Logic Controller) communication

### 7.1 Function principle

This communication method uses the Modbus protocol (ASCII and RTU for the RS232 and RS485 ports, as well as Modbus/TCP over Ethernet). Communication takes place between a panel, or a PC, and exactly one "controller" via RS232, RS485, or Ethernet.

The front connector is an RS232 interface.

The connector at the bottom of the device is an RS485 interface.

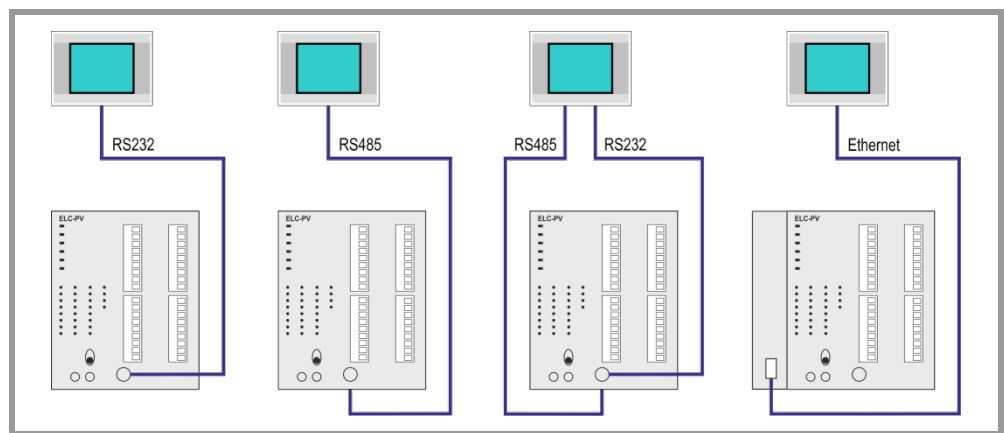

Fig. 9 How it works with panels

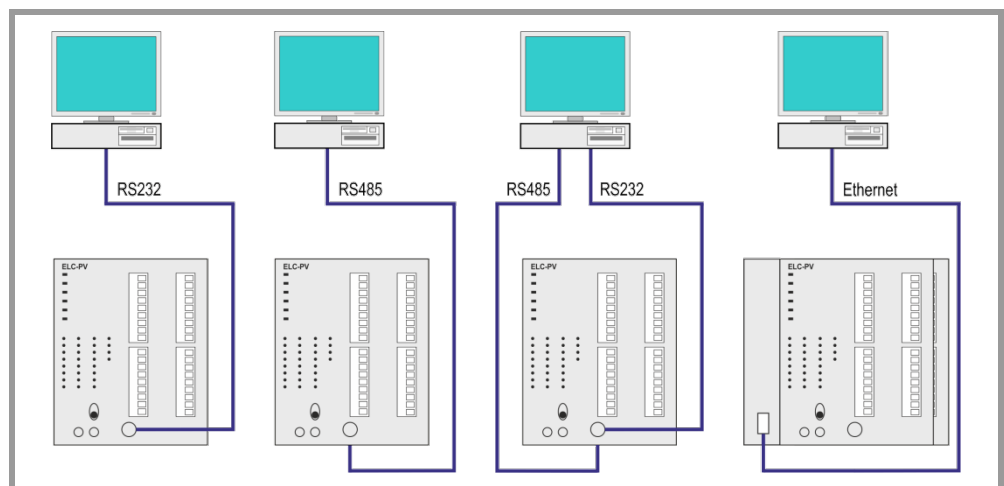

Fig. 10 How it works with PCs

## 7.2 Communication parameters

The baud rate settings for the "client" and the "controller" must be identical.

The "client" uses node address 0.

Configure the "controller's" RS232 or RS485 port as follows:

- Node address: Can be specified using the communication parameters
- System Mode
- Modbus (ASCII / RTU / TCP)
- 7 Data Bits, Even Parity, 1 Stop Bit (= Modbus ASCII)
- 8 Data Bits, Even Parity, 1 Stop Bit (= Modbus RTU/TCP)
- No Handshaking
- BCC or CRC Error Detection
- 1000 ms ACK Timeout

### 7.2.1 Supported systems

#### 7.2.1.1 Client

The following devices can communicate with ELCs (Eaton Logic Controllers):

- PC with GALILEO Open and RS232 or RS485 interface
- XV series panel with RS232 or RS485 interface
- XC series panel with RS232 or RS485 interface

Starting here, the term "client" will be used in order to refer to these devices and the software running on them.

#### 7.2.1.2 Server:

All ELC "controllers" are supported:

- ELC PV (the highest category that has been tested)

Starting here, the term "controller" will be used in order to refer to all ELC devices.

7.3

Supported data

7.3.1

Addresses

designation	Address range	Data Type
S	0 ... 1023	Bit
X	0 ... 377 oct (z.B. 0...7, 10...17)	Bit
Y	0 ... 377 oct	Bit
T	0 ... 255	Bit / Word
M	0 ... 4095	Bit
Cc	0 ... 255	Bit / Word
D	0 ... 9999	Word

Tab. 6 Supported addresses

7.4

Cable assembly and termination

Pin assignment for the RS232 programming interface on the controller.

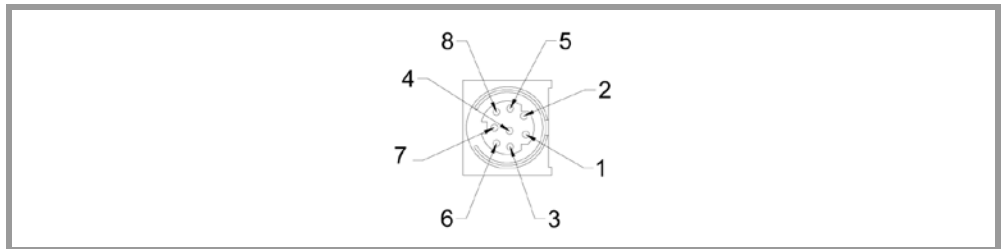

Fig. 11 Pin assignment for the port on the controller

Pin No.	designation
1	+5 V
2	+5 V
3	GND
4	Rx
5	Tx
6	GND
7	NC
8	GND

Tab. 7 Pin assignment for the port on the controller

## 7 Overview of ELC (Eaton Logic Controller) communication

### 7.4 Cable assembly and termination

RS232 cable dimensions.

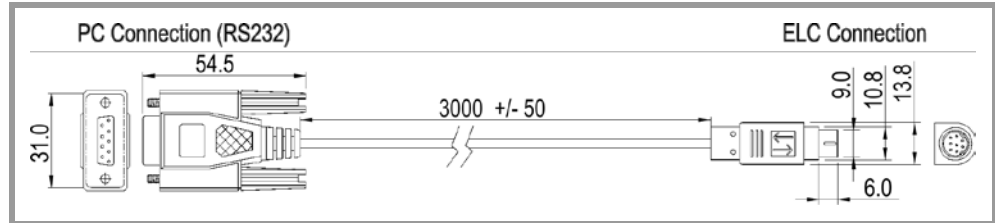

Fig. 12 RS232 cable

PC/HMI COM port 9-pin female D-sub	↔	ELC COM1 Port 8 Pin MINI DIN
Rx	2 ↔ 5	Tx
Tx	3 ↔ 4	Rx
GND	5 ↔ 8	GND
1 } 4 } 6 }	7 } 8 }	1.2 } 5 V }

Tab. 8 Pin assignment for RS232 plug

Both the "client" and the "controller" feature an RS232 and/or RS485 port and can be connected using this port.

## 8 Overview of SIMATIC S7 communication

### 8.1 Function principle

This documentation describes the following three communication options:

- Siemens – MPI  
for panels with an MPI/DP interface.
- Siemens – Industrial Ethernet  
for panels with an Ethernet interface.
- Siemens – S7 Profibus Standard Profile  
for panels with an MPI/DP interface.

#### 8.1.1 Panel on MPI/PROFIBUS-DP network

The connection to the SIMATIC S7 is made either directly via the CPU's programming port (MPI) or via a PROFIBUS port (CPU or CP) that supports S7 communication. In this regard, no function blocks need to be enabled and, in the case of MPI, no parameters need to be configured. As soon as the panel is connected to the network, it will be shown with the configured node number in the PG, under "Accessible Nodes." However, you will not be able to establish a connection to the node with the PG. If you attempt to establish a connection anyway, the panel will reject the connection and the PG will show a prompt saying "User refuses connection setup."

The panel can establish an active connection to a maximum of 42 nodes (SIMATIC S7 PLCs) simultaneously.

**Note:**  
SIMATIC PLCs only support a limited number of connections. Each panel will take up at least one OP connection.

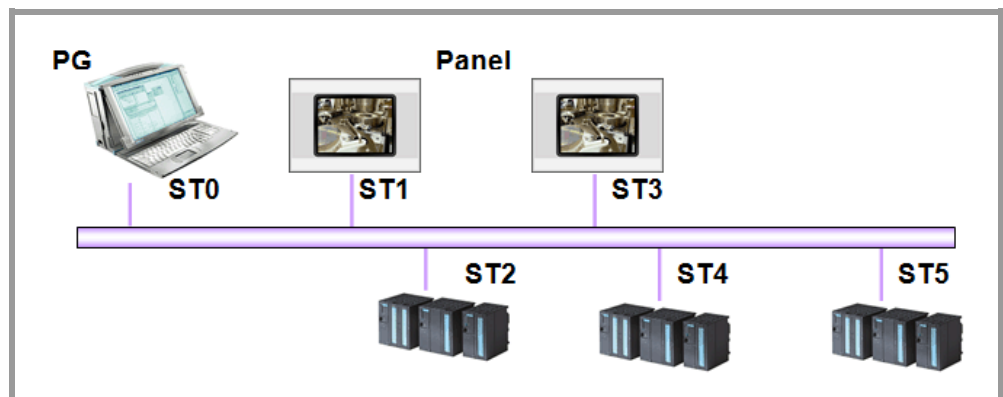

Fig. 13 How the panel works on an MPI/PROFIBUS-DP network

## 8 Overview of SIMATIC S7 communication

### 8.1 Function principle

The following are the default settings for the addresses in the MPI network:

- MPI address 0 is reserved for the SIMATIC PG.
- MPI address 1 is the default setting for an Operator Panel (MMI)
- MPI address 2 is the default setting for a PLC
- MPI addresses 3 to HSA (highest station address) are freely available

#### 8.1.2

#### Panel on Industrial Ethernet network

The connection to the SIMATIC S7 is made directly using the CPU's or CP's Ethernet port. In this regard, no additional parameters need to be configured and no function blocks need to be enabled. Another option is to use a gateway (router) to communicate with other PLCs on the MPI/PROFIBUS-DP network. In order to use this option, one of the nodes on the Ethernet network must take over the router function. A SIMATIC S7 station with an Ethernet interface and an MPI/PROFIBUS interface or a panel with an Ethernet port and an MPI interface can be used as a router.

For information on how to use a panel as a router, please refer to the "S7 PG Router" user manual.

The panel can establish a connection to multiple nodes (SIMATIC S7 PLCs) simultaneously.

**Note:**  
SIMATIC PLCs only support a limited number of connections. Each panel will take up at least one OP connection.

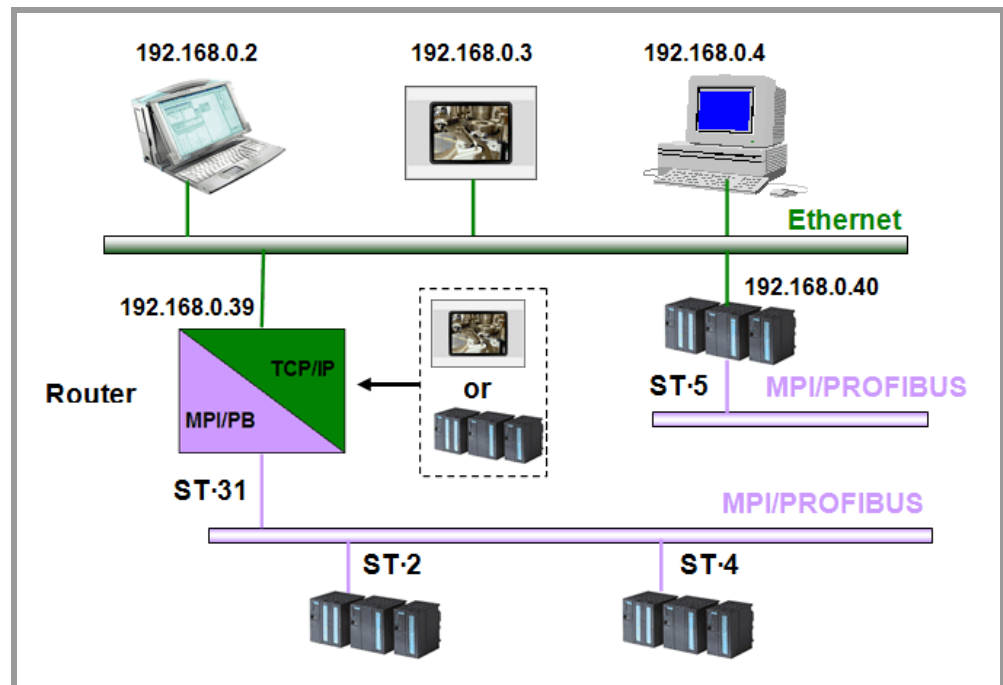

Fig. 14 How the panel works on an Industrial Ethernet network



**Note:**  
The station and IP addresses shown above are examples. What is important is for each individual node to be assigned its own unique station and/or IP address.

## 8.2

### Communication parameters

#### 8.2.1

##### Addresses

Addresses are assigned based on SIMATIC syntax conventions. All common data types are supported.

Address syntax without station number	Data Block
AB %d.%d	Out
EB %d.%d	input
MB %d.%d	Marker
DB %d.DBX %d.%d	
DB %d.DBB %d	Data access in data function block
DB %d.DBW %d	
DB %d.DBD %d	

Tab. 9 Supported addresses without station number

Address syntax with station number	Data Block
ST %d:AB %d.%d	Out
ST %d:EB %d.%d	input
ST %d:MB %d.%d	Marker
ST %d:DB %d.DBX %d.%d	
ST %d:DB %d.DBB %d	Data access in data function block
ST %d:DB %d.DBW %d	
ST %d:DB %d.DBD %d	

Tab. 10 Supported addresses with station number

## 8 Overview of SIMATIC S7 communication

### 8.2 Communication parameters

Wildcard %d stands for a decimal number that must be entered when setting the addresses for the individual tags. ST stands for the station number on the MPI/PROFIBUS network. If a station number is not specified when assigning addresses, the default station number from the "PLC Selection and Configuration" dialog box will be used.

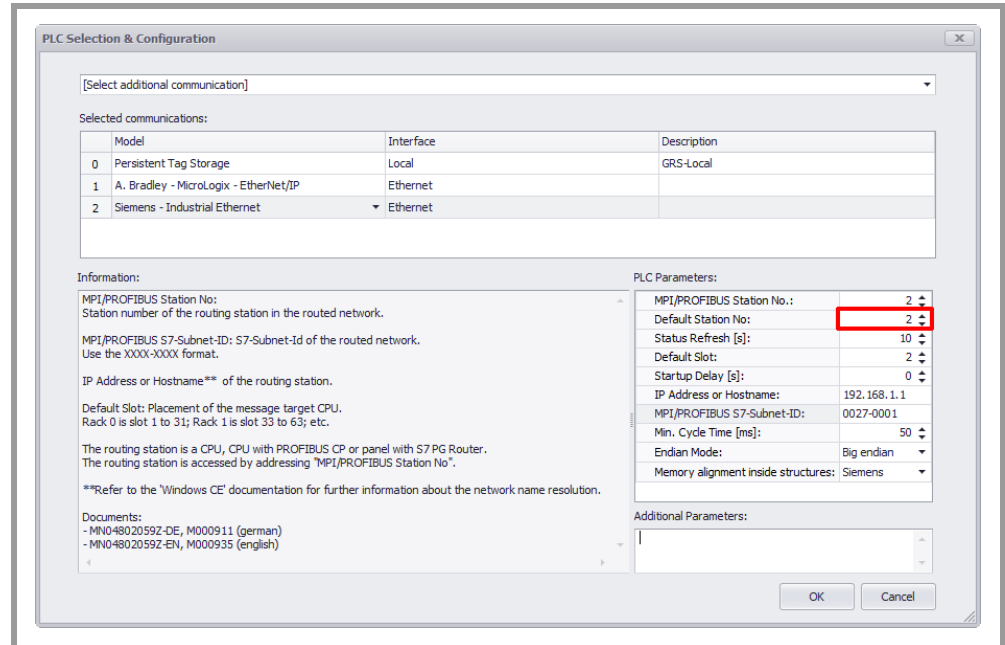

Fig. 15 PLC Selection & Configuration – Station number 2

If a station number is specified when assigning the tag's address, the default station number from the "PLC Selection and Configuration" dialog box will not be used for the tag.

## 8 Overview of SIMATIC S7 communication

### 8.2 Communication parameters

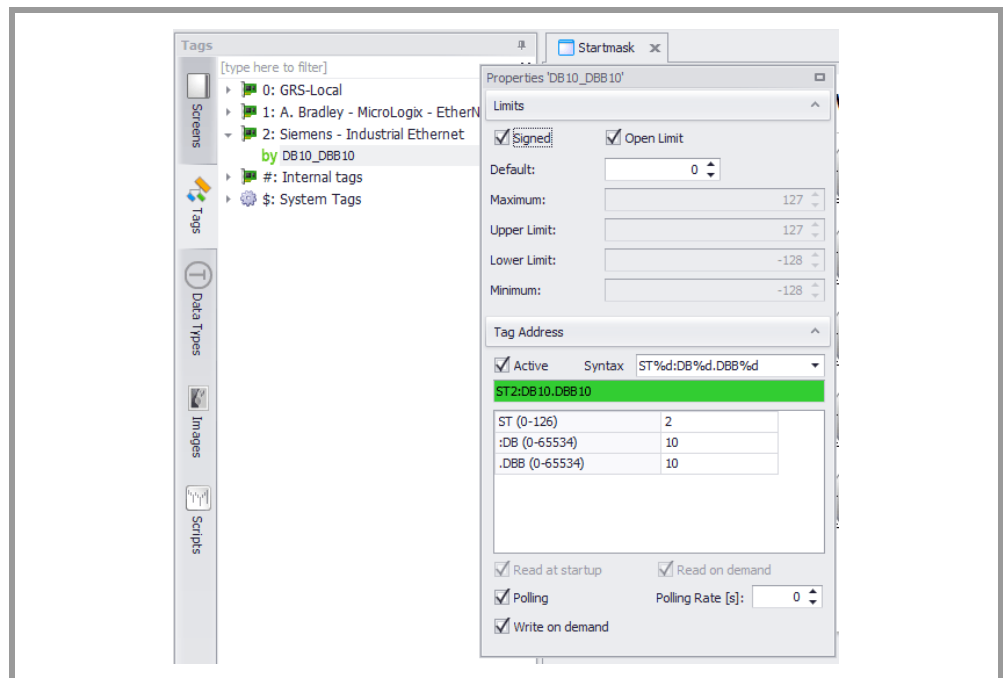

Fig. 16 Setting an address – DB10\_DBB10

#### 8.2.2 Memory Alignment

Memory alignment defines how the individual tags in a structure are stored in the PLC's memory. With Siemens, data function blocks are normally defined with a memory alignment of 2 bits. For more information on memory alignment, please refer to the documentation for Galileo or to the online help for Galileo.

#### 8.2.3 Status Refresh

For information on startup delays, please refer to the online help for Galileo.

#### 8.2.4 Default Slot

The rack slot for the CPU to which an address is being assigned must be entered. If the network cable is connected directly to the SIMATIC S7 CPU (MPI/DP), a value of 0 can be entered. Rack 0 has slots 1 to 31, Rack 1 has slots 33 to 63, etc.

This setting will apply to all the stations corresponding to a connection.

## 8 Overview of SIMATIC S7 communication

### 8.2 Communication parameters

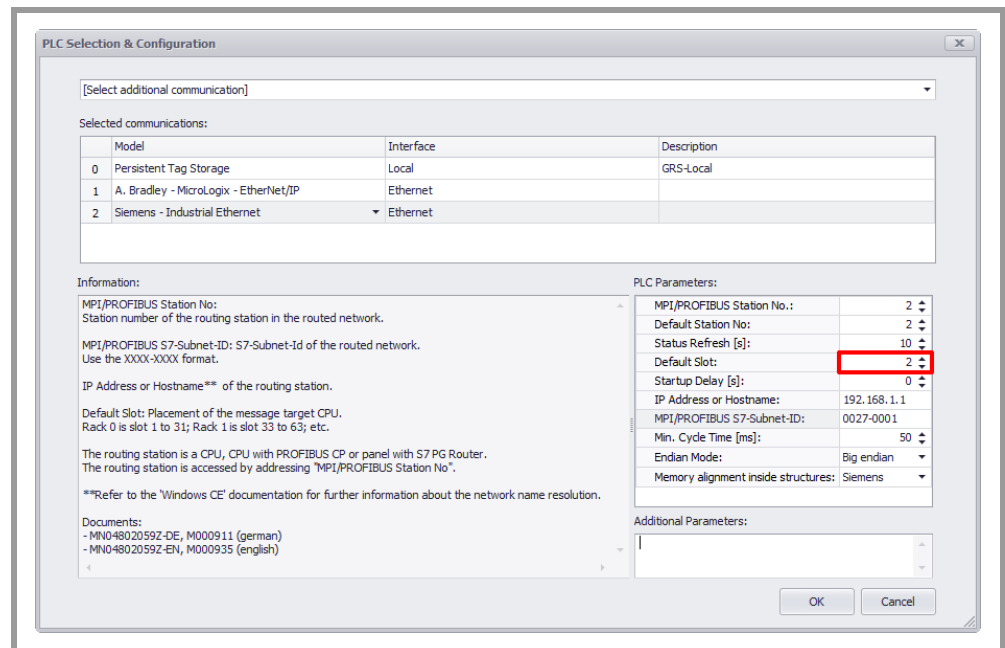

Fig. 17 PLC Selection & Configuration – Default slot 2

## 9 Overview of SIMATIC S7 / 200 PPI communication

### 9.1 Function principle

This documentation describes the following three communication options:

- Siemens – PPI  
for panels with a PROFIBUS interface.

This communication method requires a panel with a PROFIBUS interface.

For information on the communication cable, please consult the PROFIBUS section in the "Installation Instructions, General Wiring Information" document.

Regardless of the number of connections, there must be 40 available license points on the device.

**Note:**

**If you have any questions concerning license products, please contact your panel distributor.**

#### 9.1.1 Panel on PROFIBUS network

The connection to the SIMATIC S7-200 is made directly via the CPU's programming port (PPI) that supports the PPI protocol. In this regard, no function blocks need to be enabled. As soon as the panel is connected to the network, it will be shown with the configured node number in the PG, under "Communication." However, you will not be able to establish a connection to the node with the PG. The panel will be shown as "UNKNOWN address: n".

The panel can establish an active connection to multiple nodes (SIMATIC S7-200 PLCs) simultaneously.

**Note:**

**Networks featuring multiple panels and S7-200 stations will be affected by various factors. The baud rate and the number of stations will have a direct impact on communications and, when the baud rates are low, may result in communication errors (timeouts).**

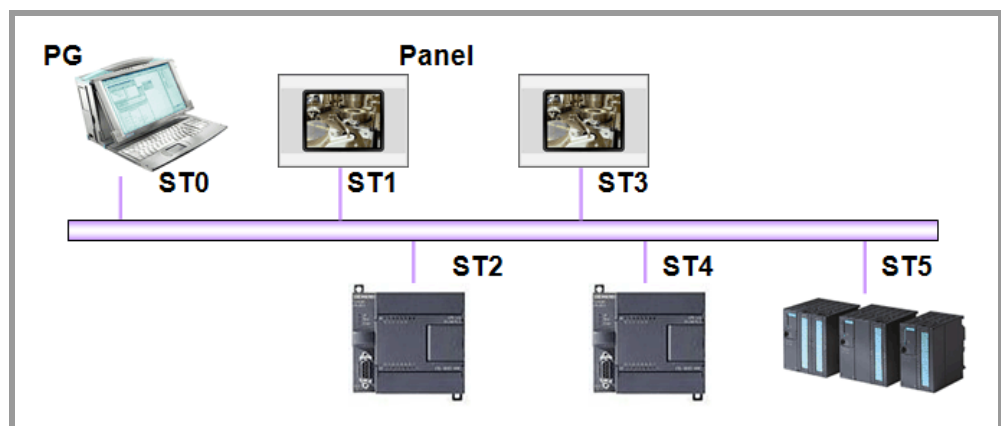

Fig. 18 How the panel works on an MPI/PROFIBUS-DP network

## 9 Overview of SIMATIC S7 / 200 PPI communication

### 9.2 Communication parameters

The following are the default settings for the addresses on the network:

- Address 0 is reserved for the SIMATIC PG.
- Address 1 is the default setting for an Operator Panel (MMI)
- Address 2 is the default setting for a PLC
- Addresses 3 to HSA (highest station address) are freely available

**Note:**  
Both the MPI and the PPI protocols can be used on the same network, e.g., ST1 with ST2 and ST4 using PPI and ST3 with ST5 using MPI. For this to work, the baud rate and the HSA of all the stations on the network must match.

## 9.2 Communication parameters

### 9.2.1 Addresses

Addresses are assigned based on SIMATIC syntax conventions. All common data types are supported.

Address syntax without station number	Data Block
A %d.%d	Output (digital)
AB %d.%d	
E %d.%d	Input (digital)
EB %d.%d	
M %d.%d	Marker
MB %d.%d	
MW %d.%d	
MD %d.%d	
V %d.%d	Variable memory
VB %d.%d	
VW %d.%d	
VD %d.%d	

Tab. 11 Supported addresses without station number

## 9 Overview of SIMATIC S7 / 200 PPI communication

### 9.2 Communication parameters

Address syntax with station number	Data Block
ST %d: A %d.%d	Output (digital)
ST %d: AB %d.%d	
ST %d: E %d.%d	Input (digital)
ST %d: EB %d.%d	
ST %d: M %d.%d	Marker
ST %d: MB %d.%d	
ST %d: MW %d.%d	
ST %d: MD %d.%d	Variable memory
ST %d: V %d.%d	
ST %d: VB %d.%d	
ST %d: VW %d.%d	
ST %d: VD %d.%d	

Tab. 12 Supported addresses with station number

Wildcard %d stands for a decimal number than must be entered when setting the addresses for the individual tags. ST stands for the station number on the network. If a station number is not specified when assigning addresses, the default station number from the "PLC Selection and Configuration" dialog box will be used.

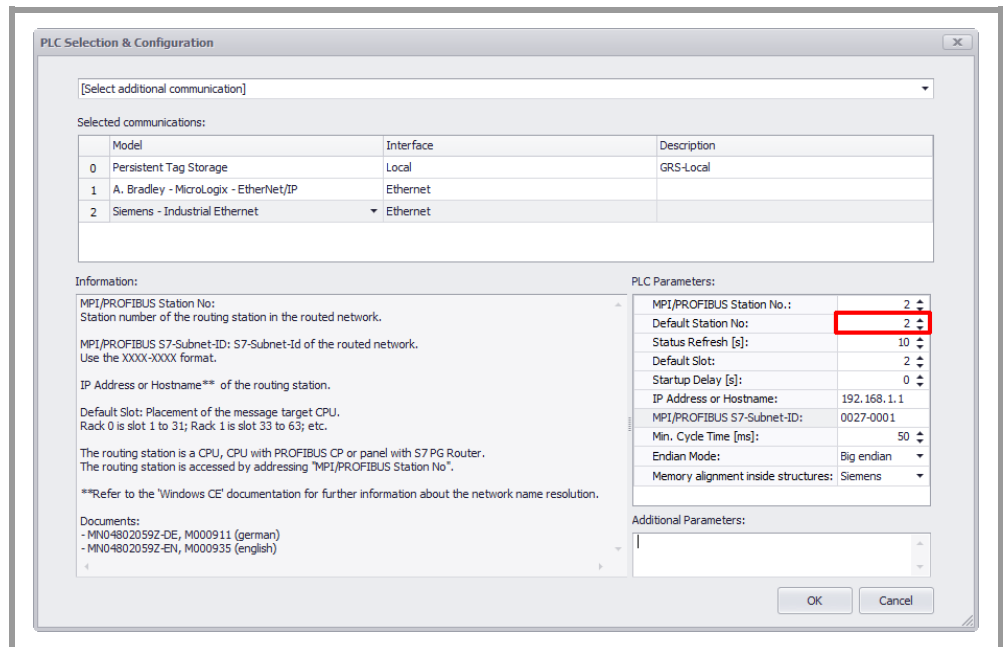

Fig. 19 PLC Selection & Configuration – Station number 2

## 9 Overview of SIMATIC S7 / 200 PPI communication

### 9.2 Communication parameters

If a station number is specified when assigning the tag's address, the default station number from the "PLC Selection and Configuration" dialog box will not be used for the tag.

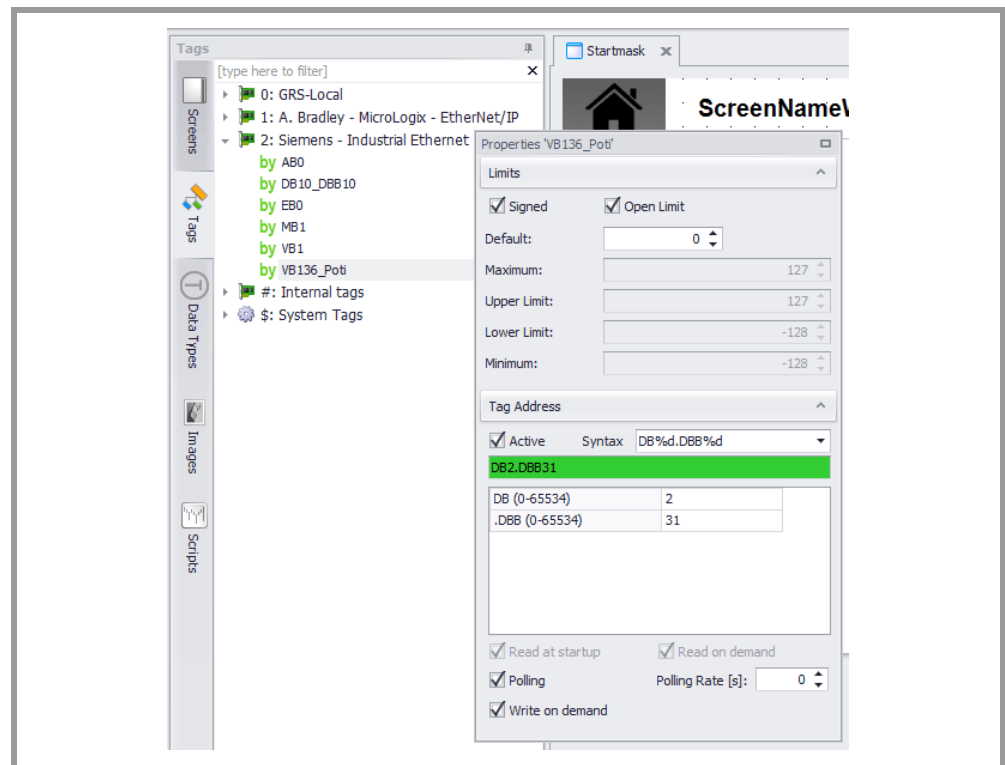

Fig. 20 Setting an address – VB136

#### 9.2.2

#### Strings

There are two generations of S7-200 controllers, hereafter referred to as CPU-21x and CPU-22x. A string tag can be declared as a "char array" and as a "STRING" type in both PLC generations.

Example:

'Hello World' Char array

"Hello World" STRING

The difference is in the single/double quotation marks.

CPU-21x controllers will store both string types as null-terminated strings in their memory.

In contrast, CPU-22x controllers will only store char array tags as null-terminated strings. STRING variables will instead be stored as Pascal strings.

Due to these differences, STRING tags for CPU-22x controllers are not supported in GALILEO.



9.2.3

**Memory Alignment**

Please refer to the Galileo online help.

## 10

## Hardware

For information on installation, wiring, and commissioning, please refer to the operator manuals for the devices.

## 11 Licensing

For information on installation, wiring, and commissioning, please refer to the operator manuals for the devices.

### 11.1 General

The panels feature an integrated licensing system. Each function used will require a certain number of license points. Moreover, certain device models will already come with a specific number of license points. The current number of license points will be shown when the panel is started, as well as in the System Information dialog box.

**Note:**  
Licensing is only required for advanced/optional functionalities! Licenses must be added specifically for each individual device, i.e., the activation code provided by the distributor will only work on the MICRO PANEL with the appropriate serial number!

#### 11.1.1 License Administrator



Fig. 21 License Administrator

License Administrator can be used to add license points to a device.

**Serial:** Shows the device's serial number. This number is printed on the device's nameplate.

**Points:** This field will show the number of device license points currently installed.

**Change License:** If you press this button, a keypad that can be used to manually enter an activation code will appear. Please refer to the *How to add license points* section as well.

### Display pane

This field will show the applications and drivers that are currently running and that require license points. Within this context, "**Withdrawn**" and "**Rejected**" mean the following:

**Withdrawn**      This is the number of license points being used by the applications shown.

**Rejected**      The system does not have enough license points for the applications shown.

**Note:**

License points being used by an application will remain unavailable even after the application is closed, i.e., they will not become available again until the device is restarted. License points cannot be removed from a device.

## 11.1.2

### How to add license points

#### With a license product certificate:

Fill out the license product certificate completely. All other information needs to be gathered from the license product certificate. After this, you will be sent an e-mail with the activation code corresponding to your order. This e-mail will also include a description of how to activate the points on your device. The License Administrator section shows one way to activate these points.

#### Without a license product certificate:

Please contact your panel's distributor. The following information will be required in order to place a license point order:

- The functionalities you want
- The serial numbers for all the panels to which you want to add license points

**Note:**

You can find the serial number on the device's nameplate, as well as in the System Information and License Administrator dialog boxes.

11.1.3

Overview showing the license points required for various functionalities

Communication	Licence points	
	Panel	PC
Allen Bradley – Logix – DF1	40	40
Allen Bradley – Logix – EtherNet/IP	40	40
Allen Bradley – SLC 5/03 – MicroLogix – DF1	40	40
CODESYS V2	40	80
CODESYS V3	40	80
ELC ASCII	40	40
ELC RTU	40	40
ELC TCP	40	40
Modbus ASCII	40	40
Modbus RTU	40	40
Modbus TCP	40	40
Siemens – Industrial Ethernet	40	40
Siemens – MPI	40	–
Siemens – PPI	40	–
Siemens – S7 Profibus Standard Profile	40	–

Tab. 13 Overview showing the license points required for the various communication options

## 12 Setting up PLC communication with Galileo

### 12.1 CODESYS V2

#### 12.1.1 Select Communication

Open Galileo and create a new project for your PANEL.

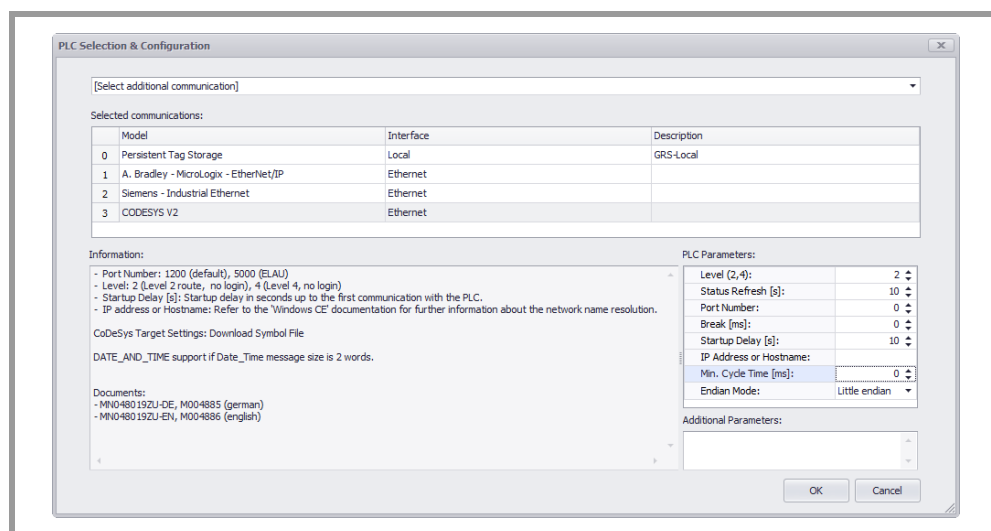

Fig. 22 PLC – Selection and Configuration – CODESYS V2

#### 12.1.2 Configuring PLC parameters

In the "PLC Selection" screen, select the appropriate "Interface" and "Model" as shown in the screenshot above.

Communication parameters	Comment
Level (2, 4):	This parameter can be used to optimize communication performance. If you cannot find any specific information for your PLC in this document, leave this parameter with its default value of 4 (optimized).
Status Refresh [s]:	For more information, read the online help for your GALILEO version.
Port number	Enter the port number that the PLC will use to provide the communication service. The default port for this service is 1200. Some PLCs may use other ports for this service. In this case, please contact the PLC's manufacturer or consult the documentation for the PLC if you are unable to find any specific information for your PLC in this document.
Break [ms]:	General pause, in milliseconds, required between two

## 12 Setting up PLC communication with Galileo

### 12.1 CODESYS V2

---

	communication cycles. Since Galileo uses polling for this communication method and polling is usually extremely fast, it may be necessary to configure a pause. On one hand, to reduce the load on the network; on the other, to reduce the load on the PLC (default: 1 ms).
Startup Delay [s]:	Please refer to the help for Galileo.
IP Address or Hostname:	Enter the PLC's IP address or hostname. In the example used in this document, the IP address is 192.168.1.87. If the PLC and GRS are running on the same device, you may enter "localhost" as the address. This will be the case, for example, when CODESYS and Galileo are running on the same panel.
Min. Cycle Time [ms]:	
Endian Mode:	For PLCs that use "Intel byte order," set this parameter to "Little endian" (default). For PLCs that use "Motorola byte order," set the parameter to "Big endian."

---

#### 12.1.3

#### Assigning addresses to PLC tags

In Galileo, tags are assigned addresses like in the PLC, as per IEC 61131-3, using symbolic names.

The PLC in our example has the structure shown in the screenshot below. Now create the same structure in Galileo.

**Note:**  
For information on how to import tags from CODESYS V2, please refer to the documentation for Galileo.

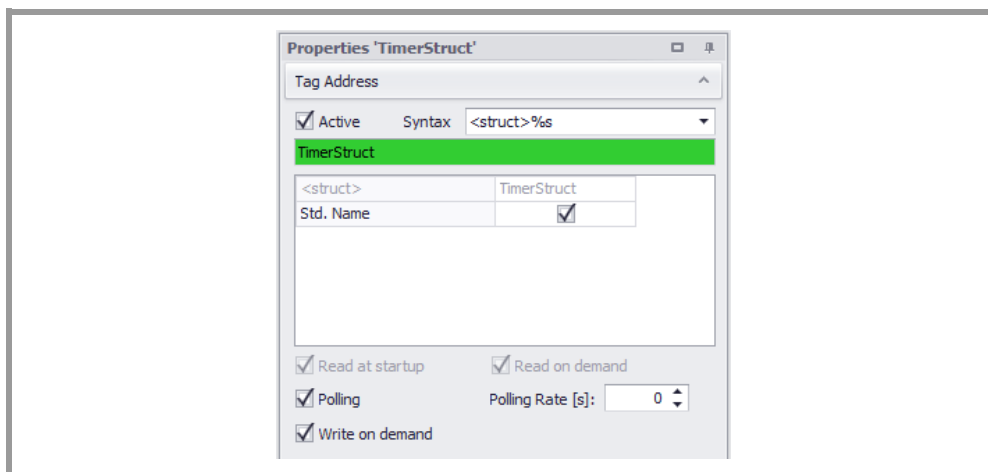

Fig. 23 Setting an address

**Whenever possible, use the same name as in the PLC!**

## 12 Setting up PLC communication with Galileo

### 12.1 CODESYS V2

Corresponding declaration in the PLC:

```
TYPE TimerType1:
STRUCT
  Description  : STRING[21];
  Day          : BYTE;
  Month       : BYTE;
  Year        : BYTE;
  Seconds     : BYTE;
  Minutes    : BYTE;
  Hours      : BYTE;
  Value      : BOOL;
  Days       : BYTE;
  Active     : BYTE;
  TimerNr    : BYTE;
END_STRUCT
END_TYPE

VAR_GLOBAL
  TimerStruct: TimerType1;
END_VAR
```

#### 12.1.4

#### Creating a test screen

Now create a new screen, add a "Value Display/Entry" control to it, and assign "TimerStruct.Year" to the control.

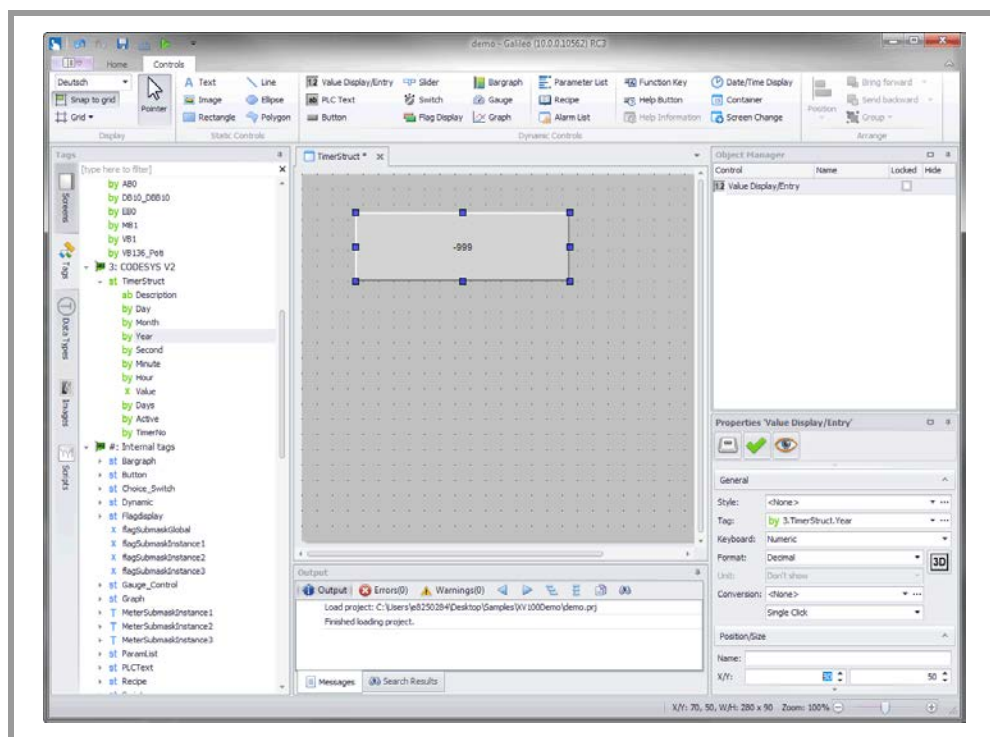

Fig. 24 "TimerStruct Year" screen

The project is now ready and can be tested directly on your computer.



12.1.5

Testing a Galileo project

Now compile the project and start Galileo Runtime by clicking on the "Build and Deploy" button.

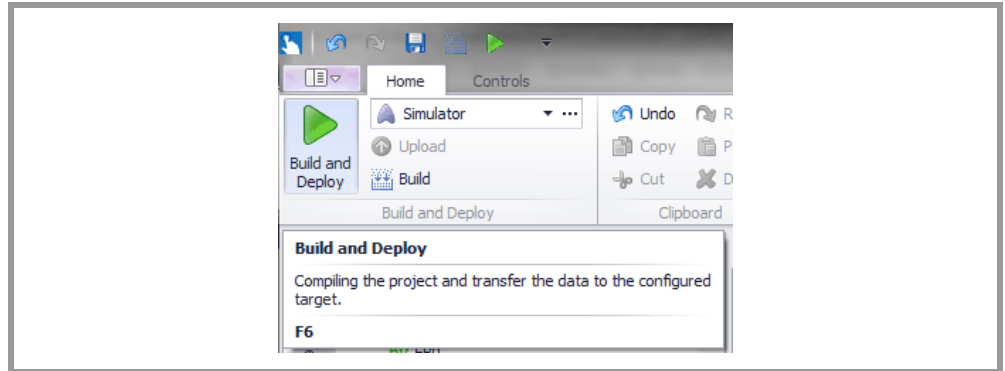
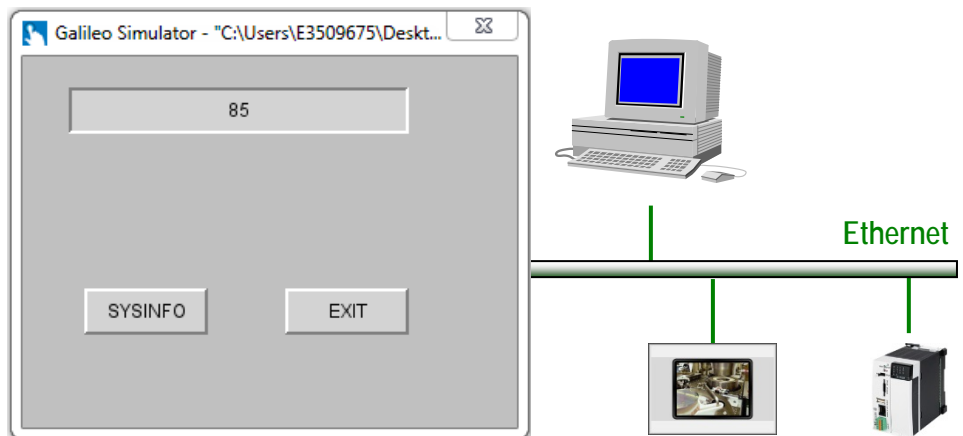

Fig. 25 Compile Project

Galileo Runtime will establish an active connection to the PLC, after which you will be able to set the "TimerStruct.Year" tag to the value you want.

**Note:**  
By default, communication will be disabled in the Design Tool. It needs to be explicitly turned on by going to Home -> Simulator -> ... -> Build & Simulator -> Simulator settings and enabling the "Communications active..." checkbox.

Exit Galileo Runtime by clicking on the "X" icon in the upper right corner or using a configured "exit" function, then run it again. If the last value you entered is shown, this means that everything has been configured properly.



You can now transfer the project to your panel and then start GRS (Galileo Runtime System). For more information, please refer to the documentation for GALILEO.

**Note:**

Normally, the PLCs can handle multiple connections simultaneously, meaning you can connect both Galileo Runtime from the Design Tool and Galileo Runtime on the panel at the same time.

If multiple GRS instances are communicating with the same CODESYS V2 PLC, there will be a higher load on the panel's CPU in comparison to when only one instance is communicating with the PLC. In this case, it may be necessary to set the "Break" and/or "Min. Cycle Time" communication parameters to a higher value.

#### 12.1.6

##### General information on CODESYS V2

Following are a couple of examples:

Eaton Automation	CODESYS
WAGO	IO-Pro
ELAU	EPAS

**Note:**

Please make absolutely sure that the names of the CODESYS V2 and Galileo tags match each other exactly, as the system will not be able to establish communications otherwise.

#### 12.1.7

##### ELAU

The following information only provides specific instructions and settings.

Eaton Automation does not provide support for the EPAS programming toolkit. If you have any questions, please contact the developer directly.

# 12 Setting up PLC communication with Galileo

## 12.1 CODESYS V2

### 12.1.7.1

### PacDrive C / PacDrive P

Select port number 5000 and level 4 for these devices, as shown in the screenshot below.

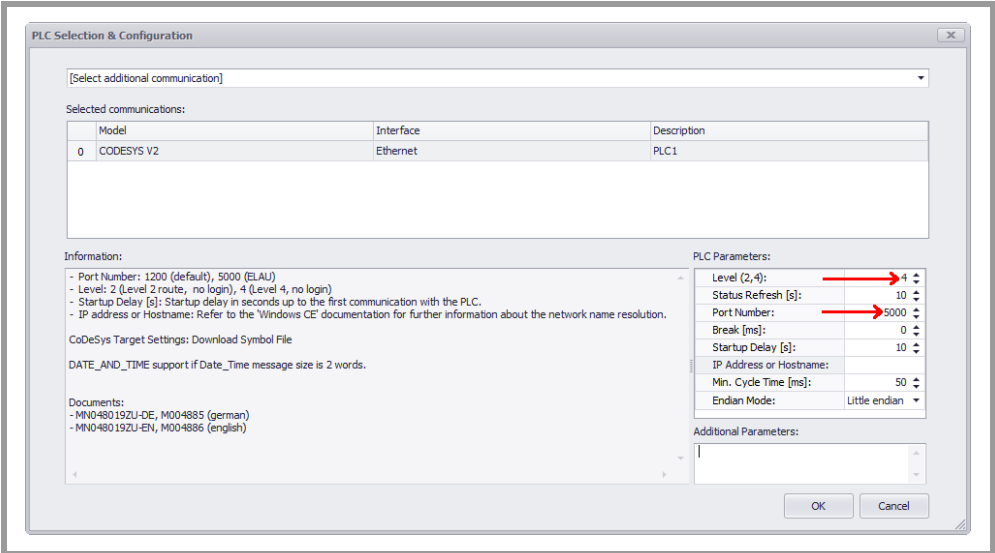

Fig. 26 PacDrive C / PacDrive P

## 12.1.8

## Turck

The following information only provides specific instructions and settings.

## 12.1.8.1

## Blxx-PG-EN

For the BLxx-PG-EN, select port number 1202, level 2, and big endian mode, as shown in the screenshot above.

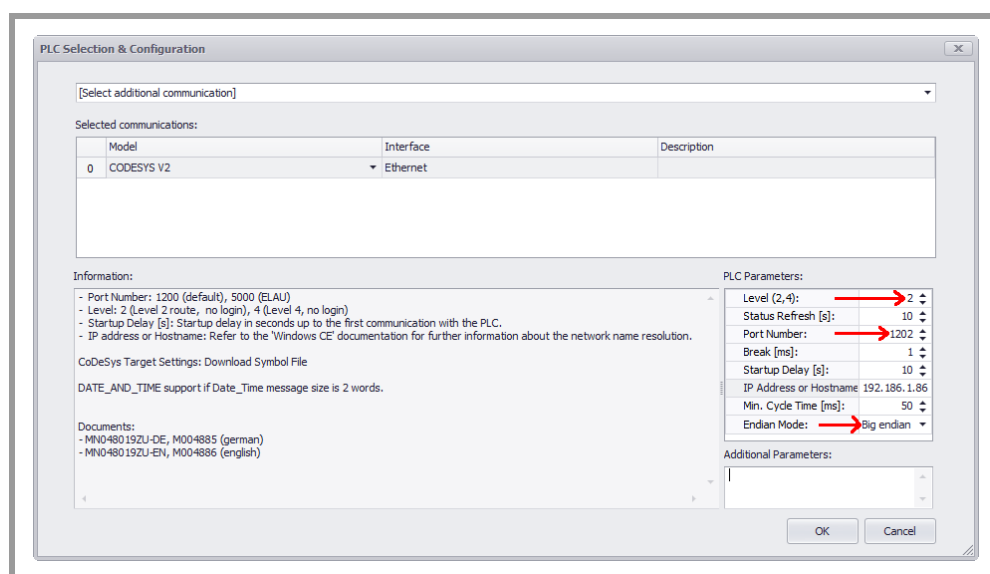

Fig. 27 Blxx-PG-EN

**Note:**

The PANEL and the BLxx-PG-EN must be on the same subnet.

There can only be one connection to the BLxx-PG-EN at a time, i.e., the programming tool and the PANEL cannot communicate with the BLxx-PG-EN simultaneously.

## 12.2

## CODESYS V3

The GALILEO visualization program supports the use of multiple parallel communication channels. One communication channel is needed for each application in a "CODESYS V3." And, if necessary, you can instead set up multiple communication channels for a single application in a "CODESYS V3."

## 12.2.1

## Setting up communication

Select "CODESYS V3" and configure the communication parameters as required.

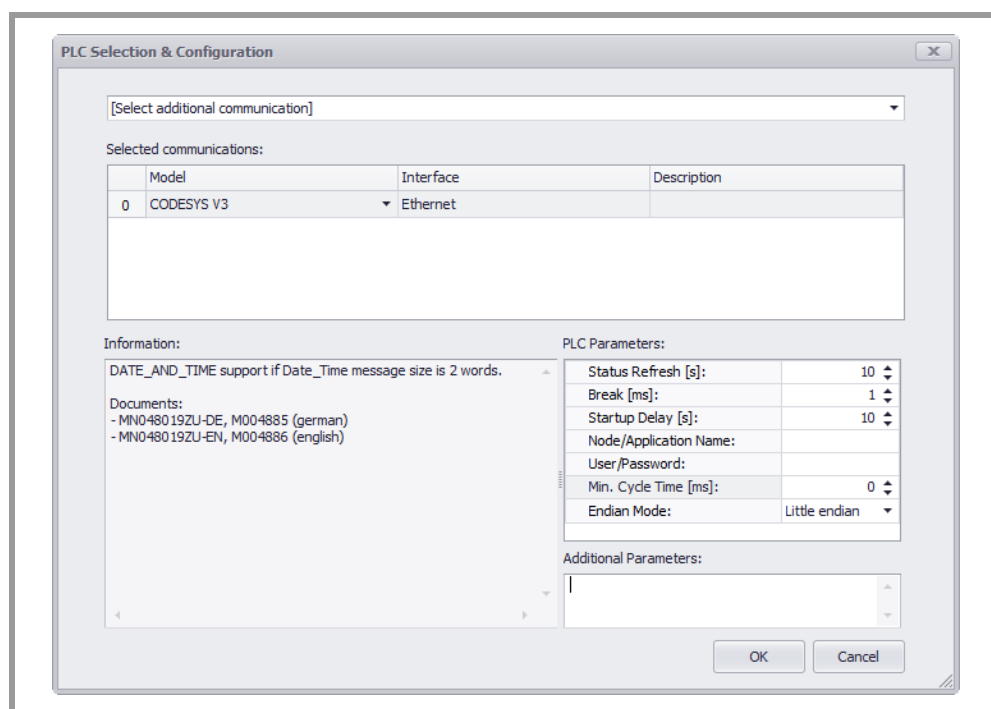

Fig. 28 Configuring communications in GALILEO without authentication parameters

Communication parameters	Comment
Status Refresh	Read the online help for your GALILEO version.
Startup Delay	Read the online help for your GALILEO version.
Node/Application Name	Enter the node name and the application name for the "CODESYS V3" in this field (use "/" as a separator). <b>Note:</b> If there is no application name, use "/" at the end of the node name. For example: if the node name is "MyHost", you would enter "MyHost/" into the field.
User/Password	Enter the username for the "CODESYS V3" Enter the password for the "CODESYS V3" (use "/" as a separator).

Tab. 14 Communication parameters in GALILEO

## 12.2.1.1

## Assigning addresses to PLC tags

GALILEO supports the following address formats and data types:

GALILEO	CODESYS V3
<object>.<tag>	Tag in object
<object>.<tag>.<array index>[ ]	Array in object
<object>.<struct>.<tag>	Tag in a structure in the object
<object>.<struct>.<tag>.<array index>[ ]	Array in a structure in the object
<object>.<struct>	Structure in object
GALILEO (CODESYS V2-compatible)	CODESYS V3 { attribute 'namespace':= " }
<tag>	Tag in global tag list
<tag>.<array index>[ ]	Array in global tag list
<struct>.<tag>	Tag in a structure in the global tag list
<struct>.<tag>.<array index>[ ]	Array in a global structure in the global tag list
<struct>	Structure in global tag list

Tab. 15 Address formats in GALILEO

GALILEO	CODESYS V3
Bit	BOOL
Error bit	BOOL
Signed byte	SINT
Unsigned byte	USINT, BYTE
Signed word	INT
Unsigned word	UINT, WORD
Signed double word	DINT
Unsigned double word	UDINT, DWORD
Float	REAL
String	STRING, WSTRING

Tab. 16 Data types in GALILEO

## 12.2.2 Workarounds

### 12.2.2.1 Migrating from CODESYS V2 to CODESYS V3

The various tags in CODESYS V2 are stored in a different way in CODESYS V3:

Tag	CODESYS V2	CODESYS V3
Global tag (variable)	.globalVar	App1.GVL.globalVar
Tag (variable) in program	PLC_PRG.lokalVar	App1.PLC_PRG.lokalVar

Tab. 17 CODESYS V2 / CODESYS V3 addresses

When using global tags in CODESYS V3, the name of the global tag list is added to the name of the application. This means that all the addresses for the global tags from CODESYS V2 would have to be modified. If it is not possible to automatically modify the addresses as required, there are two workarounds available:

- CODESYS V3-compatible addresses
- CODESYS V2-compatible addresses

#### 12.2.2.2 CODESYS V3-compatible addresses

On the client, configure a separate communication channel for access to the global tags. In the "Application" parameter for this communication channel, enter both the name of the application and the name of the global tag list, separated by a point.

Example: App1.GVL

#### 12.2.2.3 CODESYS V2-compatible addresses

Current CODESYS V3 versions support address compatibility with CODESYS V2 by means of the { attribute 'namespace':= " } construct.

The client will be able to use this method if you leave the "Application" parameter empty. Please note that the client will require at least one tag in the global tag list in this case.

## 12.2.3 Communication with local runtime system dropping out

If the client and "CODESYS V3" are running on the same device, the CODESYS V3 runtime system will terminate an active communication channel under certain circumstances.

The communication channel will be selected using the following method:

- If there are one or more IP adapters, one of the IP adapters will be used.
- If there are no IP adapters, "localhost" will be used.

The number of IP adapters may change during operation if, for example, a cable is connected or disconnected. This may result in communication between the client and "CODESYS V3" dropping out for about half a minute.

## 12 Setting up PLC communication with Galileo

### 12.2 CODESYS V3

You can avoid this problem by installing "Microsoft Loopback Adapter" and assigning it an IP address. This way, there will always be an IP adapter and "localhost" will not need to be used. When establishing a connection , the client will give preference to "Microsoft Loopback Adapter."



## 12 Setting up PLC communication with Galileo

### 12.3 Allen Bradley SLC / MicroLogix

#### 12.3 Allen Bradley SLC / MicroLogix

The GALILEO visualization program supports the use of multiple parallel communication channels. One "controller" will take up one serial interface exclusively.

##### 12.3.1 Setting up communication – serial interface

Select "A. Bradley – SLC 5/03 – MicroLogix – DF1" and configure the communication parameters as required.

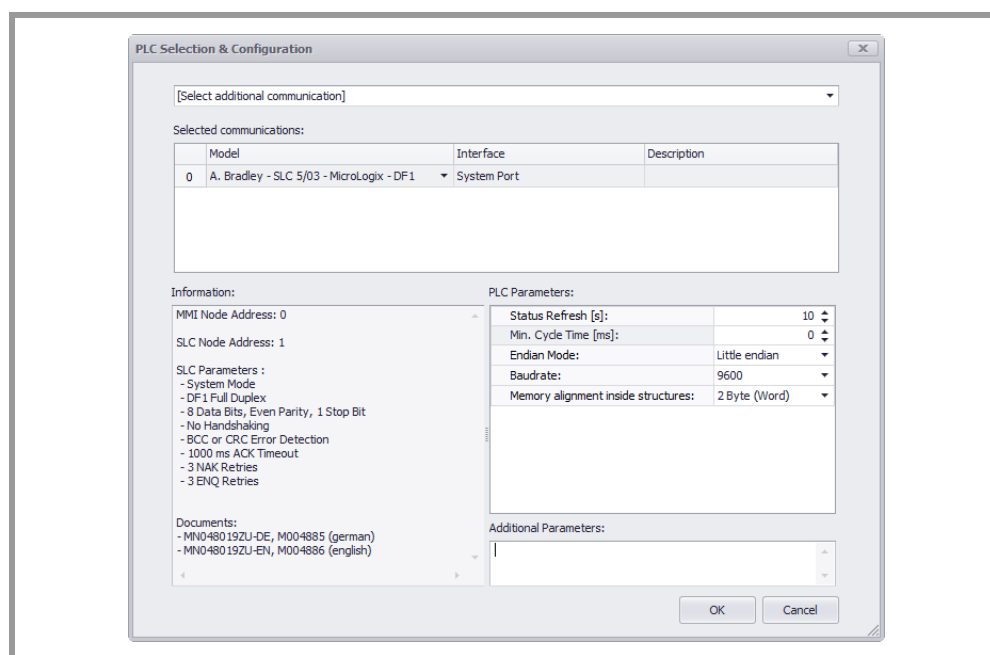

Fig. 29 Configuring communications in GALILEO – serial interface

Communication parameters	Comment
Status Refresh [s]:	For more information, read the online help for your GALILEO version.
Min. Cycle Time [ms]:	For more information, read the online help for your GALILEO version.
Endian Mode:	For more information, read the online help for your GALILEO version.
Baud Rate:	The baud rates for the "client" and "controller" must be identical.
Memory alignment inside structures:	For more information, read the online help for your GALILEO version.

Tab. 18 Communication parameters

## 12 Setting up PLC communication with Galileo

### 12.3 Allen Bradley SLC / MicroLogix

#### 12.3.2

#### Setting up communication – Ethernet interface

Select "A. Bradley – MicroLogix – EtherNet/IP" and configure the communication parameters as required.

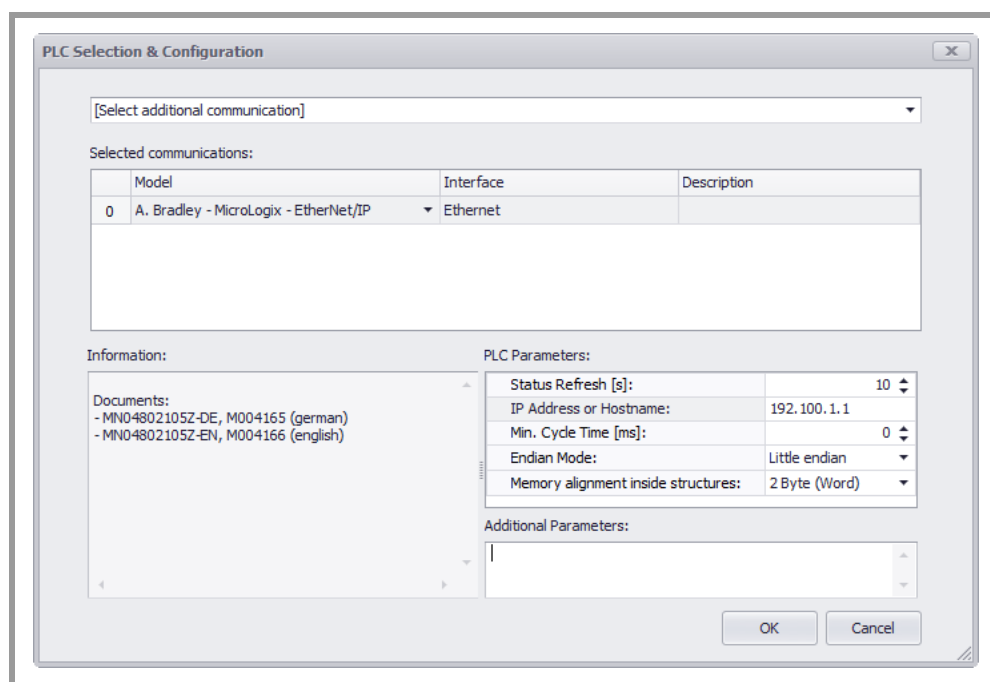

Fig. 30 Configuring communications in GALILEO – Ethernet interface

Communication parameters	Comment
Status Refresh [s]:	For more information, read the online help for your GALILEO version.
IP Address or Hostname:	IP address or hostname Example: 192.168.1.1
Min. Cycle Time [ms]:	For more information, read the online help for your GALILEO version.
Endian Mode:	For more information, read the online help for your GALILEO version.
Memory alignment inside structures:	For more information, read the online help for your GALILEO version.

Tab. 19 Communication parameters

12.3.3

Assigning addresses to tags

GALILEO supports the following address formats and data types:

GALILEO	Controller
B%d:%d C%d:%d F%d:%d N%d:%d T%d:%d	Tags on the controller.

Tab. 20 Address formats in GALILEO

GALILEO	Controller
Bit / Error	B, N
Byte:	B, N
Word	B, C, N, T
DWord	not supported
Float	F
String	not supported
Structure	B, N
System	B, N

Tab. 21 Data types in GALILEO

12.3.4

Fault messages

12.3.4.1

Local STS error codes

Local STS error codes contain errors that can occur in the local node. Following are the various possible error codes (in hex):

Code	Description
00	Success; no error
01	DST Node is out of buffer space
02	Cannot guarantee delivery; link layer The remote node specified does not ACK command
03	Duplicate token holder detected
04	Local port is disconnected
05	Application layer timed out waiting for response
06	Duplicate node detected
07	Station is offline
08	Hardware fault

Tab. 22 Local STS error codes

Local STS codes 09 to 0F (hex) are not used.

## 12 Setting up PLC communication with Galileo

### 12.3 Allen Bradley SLC / MicroLogix

#### 12.3.4.2

#### Remote STS Error Codes

Remote STS error codes contain errors that can occur in remote nodes. Following are the various possible error codes (in hex) that can occur in the STS byte:

Code	Description
00	Success; no error
10	Illegal command or format
20	Host has a problem and will not communicate
30	Remote node host is missing, disconnected, or shut down
40	Remote host could not complete function due to hardware fault
50	Addressing problem or memory protect rungs
60	Function not allowed due to command protection selection
70	Processor is in Program Mode
80	Compatibility mode file missing or communication zone problem
90	Remote node cannot buffer command
A0	Wait ACK (1775 KA buffer full)
B0	Remote node problem due to download
C0	Wait ACK (1775 KA buffer full)
D0	Not used
E0	Not used
F0	Error code in EXT STS byte (see tab. 13)

Tab. 23 Remote STS Error Codes

#### 12.3.4.3

#### EXT STS byte

If the STS code is F0 (hex), there will be an EXT STS byte.

#### EXT STS codes for CMD

Hex Code	Description
0	Not used
1	A field has an illegal value
2	Fewer levels specified in address than minimum for any address
3	More levels specified in address than system supports.
4	Symbol not found
5	Symbol is of improper format

## 12 Setting up PLC communication with Galileo

### 12.3 Allen Bradley SLC / MicroLogix

6	Address does not point to something usable
7	File is wrong size
8	Cannot complete request; situation has changed since start of the command
9	Data or file size is too large
A	Transaction size plus word address is too large
B	Access denied; improper privilege
C	Condition cannot be generated; resource is not available
D	Condition already exists; resource is readily available
E	Command cannot be executed
F	Histogram overflow
10	Inaccessible
11	Illegal data type
12	Invalid parameter or invalid data
13	Address reference exists to deleted area
14	Command execution failure for unknown reason; possible PLC 3 histogram overflow
15	Data conversion error
16	Scanner not able to communicate with 1771 rack adapter
17	Type mismatch
18	1771 module response was not valid
19	Duplicated label
22	*Remote rack fault
23	*Timeout
24	*Unknown error
1 A	File is open; another node owns it
1B	Another node is the program owner
1C	Reserved
1D	Reserved
1E	Data table element protection violation
1F	Temporary internal problem

Tab. 24 Remote STS error codes

\* These codes are used to forward a DH link to a remote I/O link

## 12.4

### Allen Bradley Logix

This communication method requires a PANEL with an Ethernet interface. For information on the communication cable, please consult the Ethernet section in the "Installation Instructions, General Wiring Information" document.

Regardless of the number of connections, there must be an additional 40 license points available on the device.

**Note:**  
If you have any questions concerning license products, please contact your PANEL distributor.

### 12.4.1

#### Setting up communication

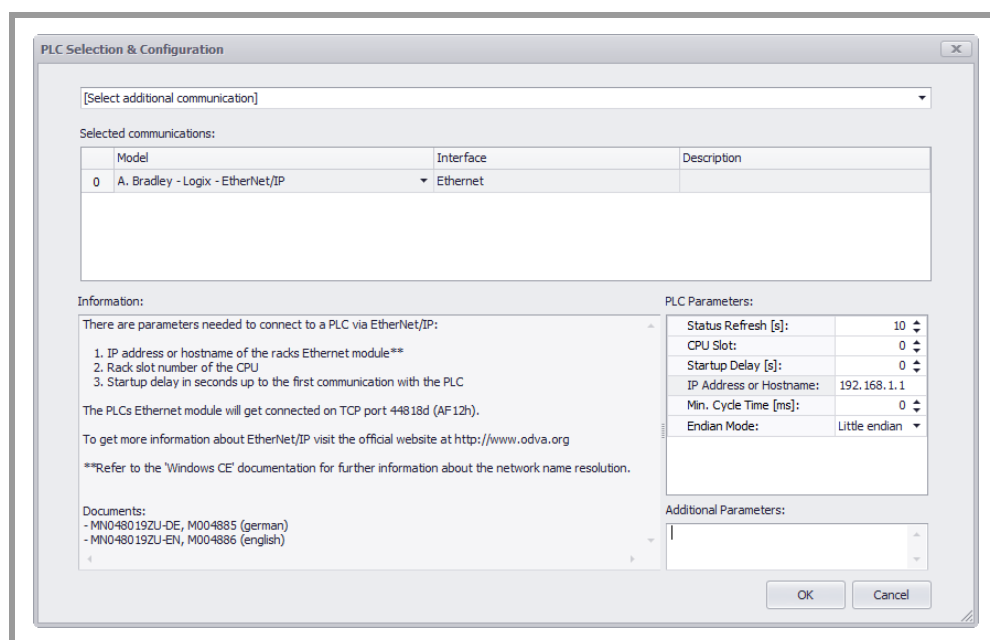

Fig. 31 Configuring communications in GALILEO for A. Bradley Logix – Ethernet/IP

**Note:**  
Galileo supports multiple connections for the Ethernet interface, i.e., multiple connections can be configured for the same port. This means that the tags (including the corresponding system structures) on multiple PLCs can be assigned addresses.

Select "A. Bradley – Logix – EtherNet/IP" in the "PLC Selection and Configuration" dialog box. The dialog box shown above will appear so that you can configure the parameters required for the corresponding communication method.

## 12 Setting up PLC communication with Galileo

### 12.4 Allen Bradley Logix

Communication parameters	Comment
Status Refresh [s]:	For more information, read the online help for your GALILEO version.
CPU Slot:	Specify the appropriate slot.
Startup Delay [s]:	For a description of this parameter, please refer to the documentation for GALILEO.
IP Address or Hostname:	The IP address entered must match the setting for the Ethernet module in the PLC rack.
Min. Cycle Time:	
Endian Mode:	This parameter defines how data is organized in the protocol.

Tab. 25 Logix – EtherNet/IP communication parameters

## 12.5 Allen Bradley Logix – DF1

This communication method requires a PANEL with an RS232 interface. For information on the communication cable, please consult the RS232 Port System section in the "Installation Instructions, General Wiring Information" document.

Regardless of the number of connections, there must be an additional 40 license points available on the device.

**Note:**  
If you have any questions concerning license products, please contact your PANEL distributor.

### 12.5.1 Setting up communication

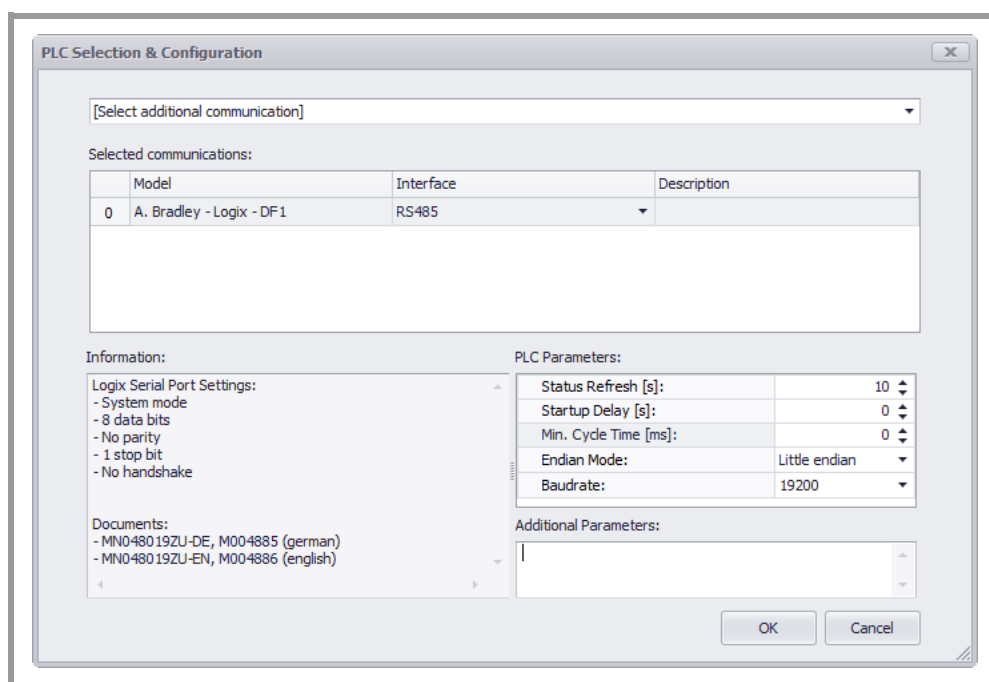

Fig. 32 Configuring communications in GALILEO – A. Bradley – Logix – DF1

**Note:**  
Galileo supports exactly one connection for the RS232 port, i.e., exactly one connection can be configured for each port.

Select "A. Bradley – Logix – DF1" in the "PLC Selection and Configuration" dialog box. The dialog box shown above will appear so that you can configure the parameters required for the corresponding communication method.



## 12 Setting up PLC communication with Galileo

### 12.5 Allen Bradley Logix – DF1

Communication parameters	Comment
Status Refresh [s]:	For more information, read the online help for your GALILEO version.
Startup Delay [s]:	For a description of this parameter, please refer to the documentation for GALILEO.
Min. Cycle Time:	
Endian Mode:	This parameter defines how data is organized in the protocol.
Baud Rate:	The baud rate setting must match the setting for the PLC. The other settings for the A. Bradley serial port will be shown in the "Information" pane in the "PLC Selection and Configuration" dialog box.

Tab. 26 Logix – DF1 communication parameters

**Note:**  
The system protocol must be set to "DF1 Point to Point" on the Logix PLC. Error detection can be set to BCC or CRC.

## 12.6

## Modbus

### 12.6.1

### Setting up communication

Open Galileo and create a new project for your panel. Galileo supports three Modbus protocol versions: Modbus RTU (Remote Terminal Unit), Modbus ASCII, and Modbus TCP. Modbus RTU and Modbus ASCII communications use serial interfaces for communication. Meanwhile, Modbus TCP uses the Ethernet interface to communicate.

**Note:**  
Due to the way in which data is packed at the protocol level, Modbus RTU is usually more efficient than Modbus ASCII.

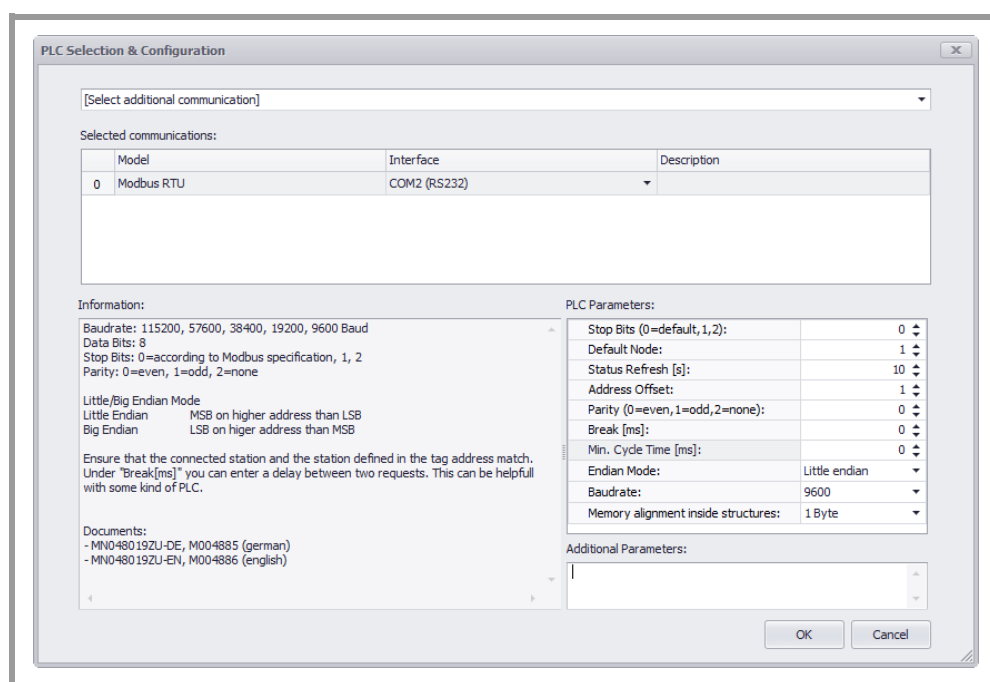

Fig. 33 Configuring communications in GALILEO – Modbus RTU

## 12 Setting up PLC communication with Galileo

### 12.6 Modbus

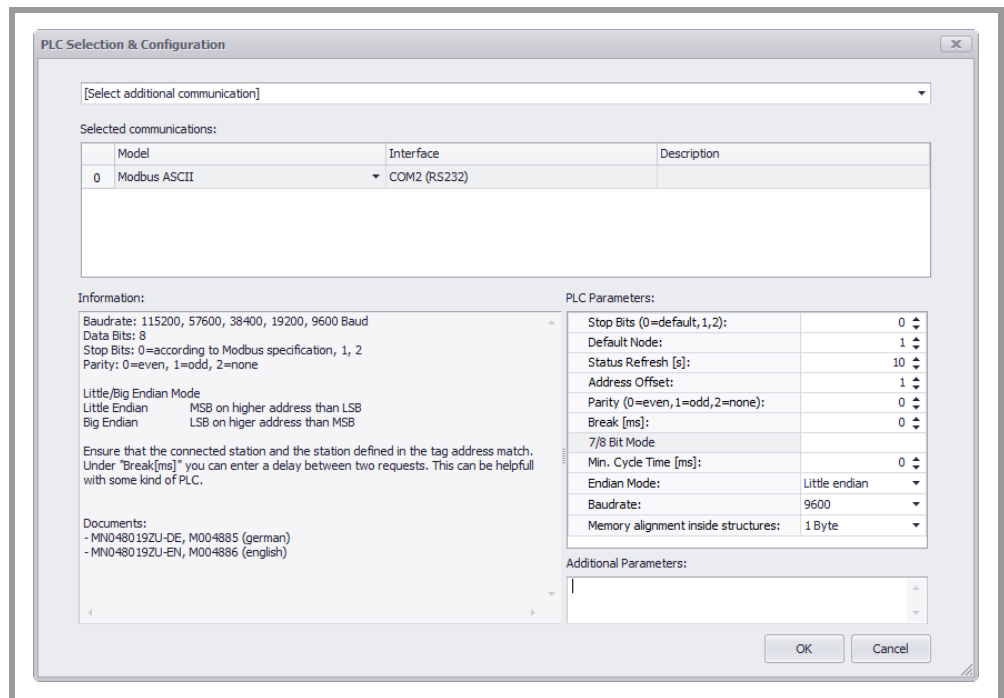

Fig. 34 Configuring communications in GALILEO – Modbus ASCII

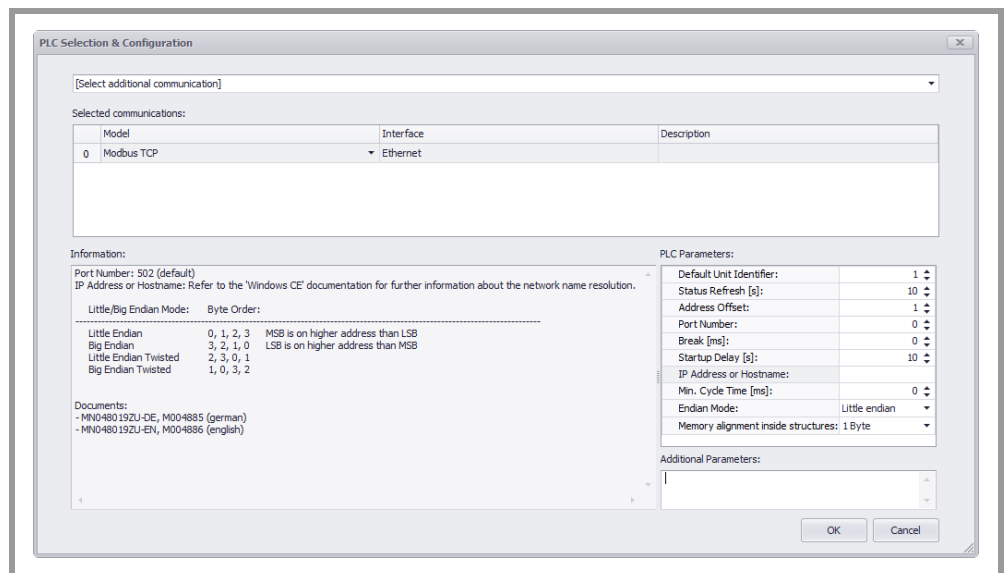

Fig. 35 Configuring communications in GALILEO – Modbus TCP

## 12 Setting up PLC communication with Galileo

### 12.6 Modbus

In "PLC Selection and Configuration," select the appropriate COM interface for Modbus RTU and Modbus ASCII. In the case of Modbus TCP, only Ethernet will be available for selection. The screenshots above show examples in which Modbus RTU, ASCII, and TCP are selected respectively.

Communication		RTU	ASCII	TCP
<b>Stopbits (0=standard, 1, 2):</b> Select the right stop bits for your controller.	<b>Parity</b> Flat	✓	✓	✗
	odd			
	None			
	<b>Stopbit</b> 1 1 2			
<b>Default Node:</b> Enter the default PLC's station number here.		✓	✓	✗
<b>Default Unit Identifier:</b> Enter the station number here.		✗	✗	✓
<b>Status Refresh [s]:</b> For a description of this parameter, please refer to the documentation for GALILEO.		✓	✓	✓
<b>Address Offset:</b> As specified in the Modbus RTU specification, the start address of a data packet minus 1 (address offset) will be transferred (GALILEO address: 5 = Protocol address: 4). If your PLC does not use this convention, select a value of 0 for this parameter.		✓	✓	✓
<b>Parity: (0=even, 1=odd, 2=none)</b> Select the right parity for your PLC. The default for Modbus RTU is 0 (even parity).		✓	✓	✗
<b>Port Number:</b> Select the port number that your PLC uses to communicate (default: 502).		✗	✗	✓
<b>Break [ms]:</b> Can be used to define a pause generated after an active data transfer with the PLC.		✓	✓	✓
<b>Min. Cycle Time [ms]:</b> For a description of this parameter, please refer to the documentation for GALILEO.		✓	✓	✓
<b>7/8 Bit Mode:</b>		✗	✓	✗
<b>Endian Mode:</b> This parameter defines how the data is organized in the protocol.		✓	✓	✓
<b>Baudrate:</b> Select the right baud rate for your PLC from the options available.		✓	✓	✗
<b>Startup Delay [s]:</b> For a description of this parameter, please refer to the documentation for GALILEO.		✓	✓	✓
<b>IP Address or Hostname:</b> Your PLC's IP address or hostname. For more detailed information on the use of hostnames, please refer to the documentation for Windows CE.		✗	✗	✓
<b>Memory alignment inside structures:</b> For a description of this parameter, please refer to the documentation for GALILEO.		✓	✓	✓

12.6.1.1

**Memory Alignment**

Memory alignment is used to define the granularity (8, 16, or 32 bits) with which data is grouped within structures.

The table below shows the effect that the memory alignment of structures has on the data map and data volume in the PLC based on the set granularity.

Data byte	GALILEO structure	Memory Alignment			
		1 bytes	2 Byte (Word)	4 Byte (DWord)	
00	Byte_a	Byte_a	Byte_a	Byte_a	
01	Word_a	Word_a			
02			Word_a	Word_a	
03	Byte_b	Byte_b			
04	DWord	DWord	Byte_b	Byte_b	
05					
06			DWord		
07					
08	Byte_c	Byte_c		DWord	
09	Word_b	Word_b			
10			Byte_c		
11					
12			Word_b	Byte_c	
13					
14				Word_b	
15					

12.6.2

**Assigning addresses to tags**

Now create a tag called "TestWord" in Galileo as shown in the screenshot below. Assign an address on your PLC to the tag.

## 12 Setting up PLC communication with Galileo 12.6 Modbus

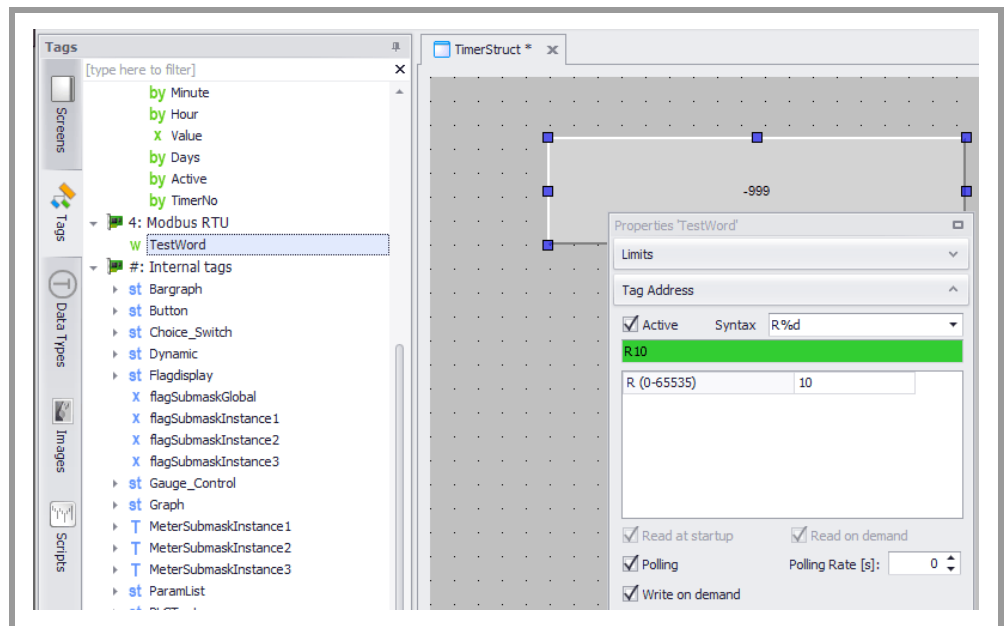

Fig. 36 Setting the address – TestWord R

The GALILEO "TestWord" tag is referenced to address R10 on the PLC, as shown in the screenshot above.

**Note:**  
If a station number is not explicitly specified for the PLC, the "Default Node" will be used.

The station number for the PLC can be explicitly specified for each tag as well (as shown in the screenshot below).

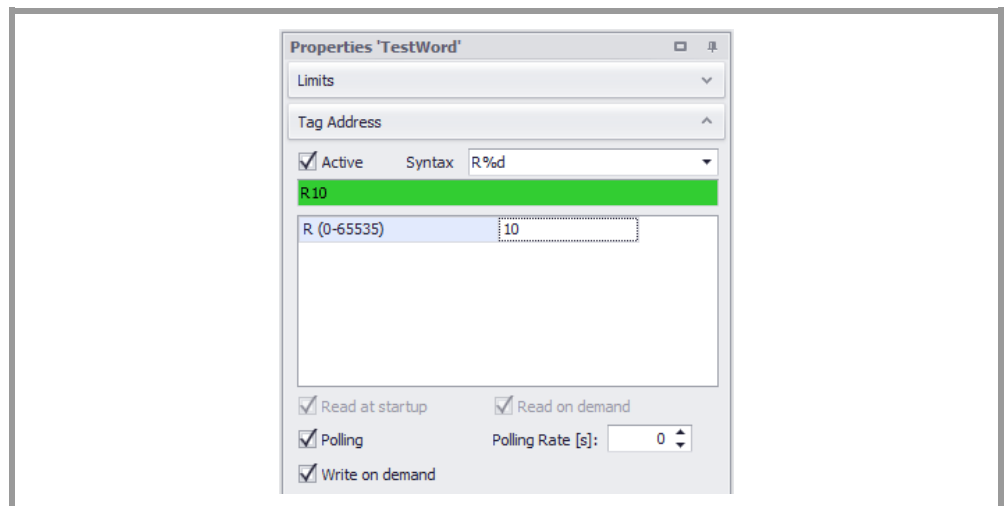

Fig. 37 Setting the address – TestWord ST5

## 12 Setting up PLC communication with Galileo

### 12.6 Modbus

In GALILEO, addresses are assigned with the condition that each memory location for types "R" and "RI" must contain a 16-bit value.

PLC address	Byte (8-bit value)	Word (16-bit value)	DWord (32-bit value)
R10.0	Byte[0] Bit 00..07	Word[0] Bit 00..07	DWord[0] Bit 00..07
R10.8	Byte[1] Bit 00..07	Word[0] Bit 08..15	DWord[0] Bit 08..15
R11.0	Byte[2] Bit 00..07	Word[1] Bit 00..07	DWord[0] Bit 16..23
R11.8	Byte[3] Bit 00..07	Word[1] Bit 08..15	DWord[0] Bit 24..31
R12.0	Byte[4] Bit 00..07	Word[2] Bit 00..07	DWord[1] Bit 00..07
R12.8	Byte[5] Bit 00..07	Word[2] Bit 08..15	DWord[1] Bit 08..15
R13.0	Byte[6] Bit 00..07	Word[3] Bit 00..07	DWord[1] Bit 16..23
R13.8	Byte[7] Bit 00..07	Word[3] Bit 08..15	DWord[1] Bit 24..31

Table with examples for linear data types with a start address of R10

In contrast, each memory location for types "M" and "MI" takes up 1 bit only.

PLC address	Byte (8-bit value)	Word (16-bit value)	DWord (32-bit value)
M17..24	Byte[0] Bit 00..07	Word[0] Bit 00..07	DWord[0] Bit 00..07
M25..32	Byte[1] Bit 00..07	Word[0] Bit 08..15	DWord[0] Bit 08..15
M33..40	Byte[2] Bit 00..07	Word[1] Bit 00..07	DWord[0] Bit 16..23
M41..48	Byte[3] Bit 00..07	Word[1] Bit 08..15	DWord[0] Bit 24..31
M49..56	Byte[4] Bit 00..07	Word[2] Bit 00..07	DWord[1] Bit 00..07
M57..64	Byte[5] Bit 00..07	Word[2] Bit 08..15	DWord[1] Bit 08..15
M65..72	Byte[6] Bit 00..07	Word[3] Bit 00..07	DWord[1] Bit 16..23
M73..80	Byte[7] Bit 00..07	Word[3] Bit 08..15	DWord[1] Bit 24..31

Table with examples for linear data types with a start address of R10

#### 12.6.3

#### Creating a test screen

Now create a new screen, add a "Value Display/Entry" control to it, and assign "TestWord" to the control.

## 12 Setting up PLC communication with Galileo

### 12.6 Modbus

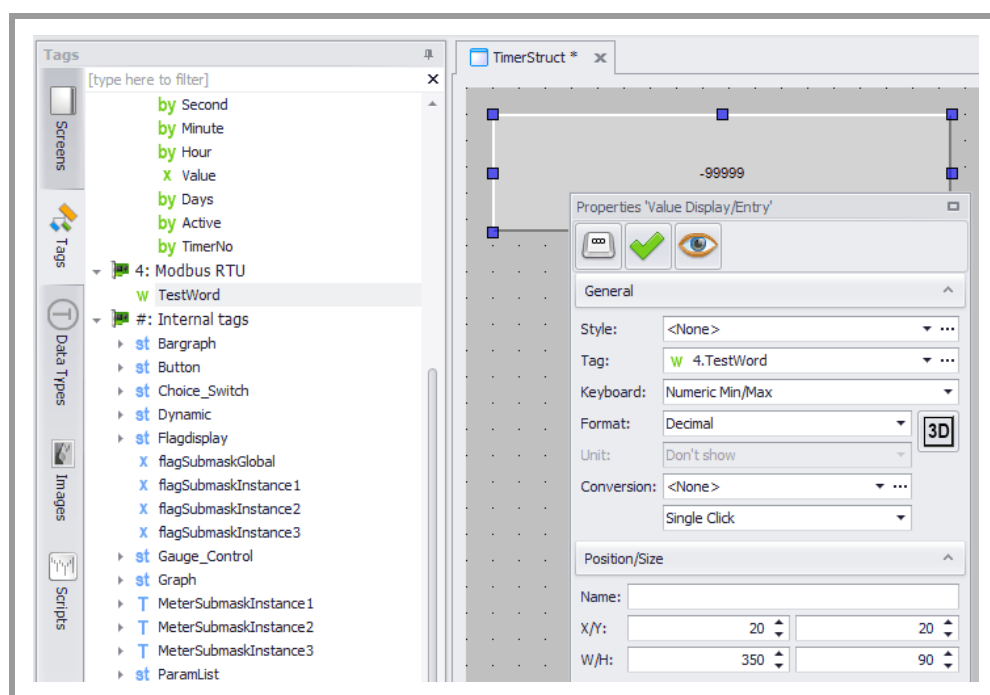

Fig. 38 Properties – TestWord

The project is now ready and communication with the PLC can now be tested.

#### 12.6.4

#### Test Project

Since Modbus RTU and ASCII work with RS232 as well, you have the option of testing your project directly on the computer. If the PLC features an Ethernet interface, Modbus TCP can also be used for communicating.

The following example assumes that Modbus RTU has been selected as the communication method.

**Requirements for communication with Modbus RTU or Modbus ASCII:**  
The PLC interface must support the RS232 standard.

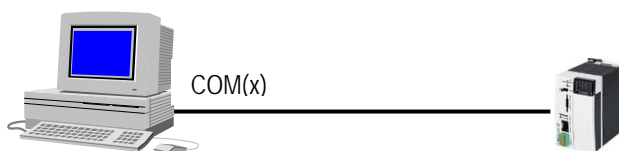

Use a communication cable to connect the PC and the PLC.

Now compile the project you created previously and run Galileo Runtime by clicking on the green arrow button.



# 12 Setting up PLC communication with Galileo

## 12.6 Modbus

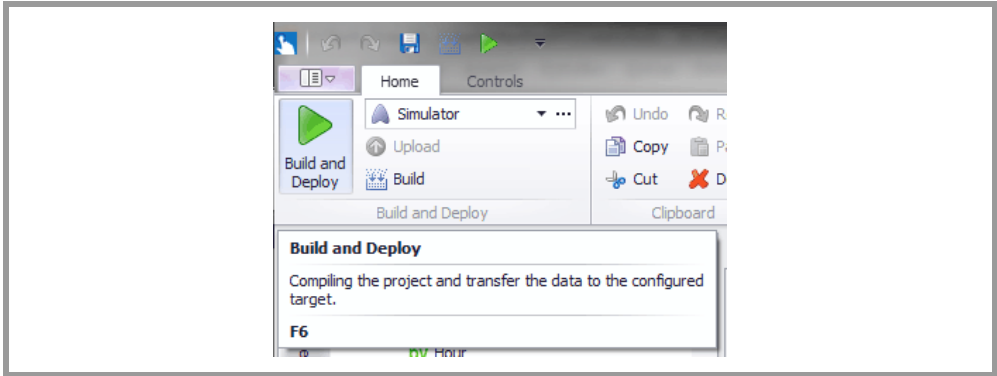

Fig. 39 Compile Project

The first time, you will need to specify the PC COM interface that is being used to connect to the PLC.

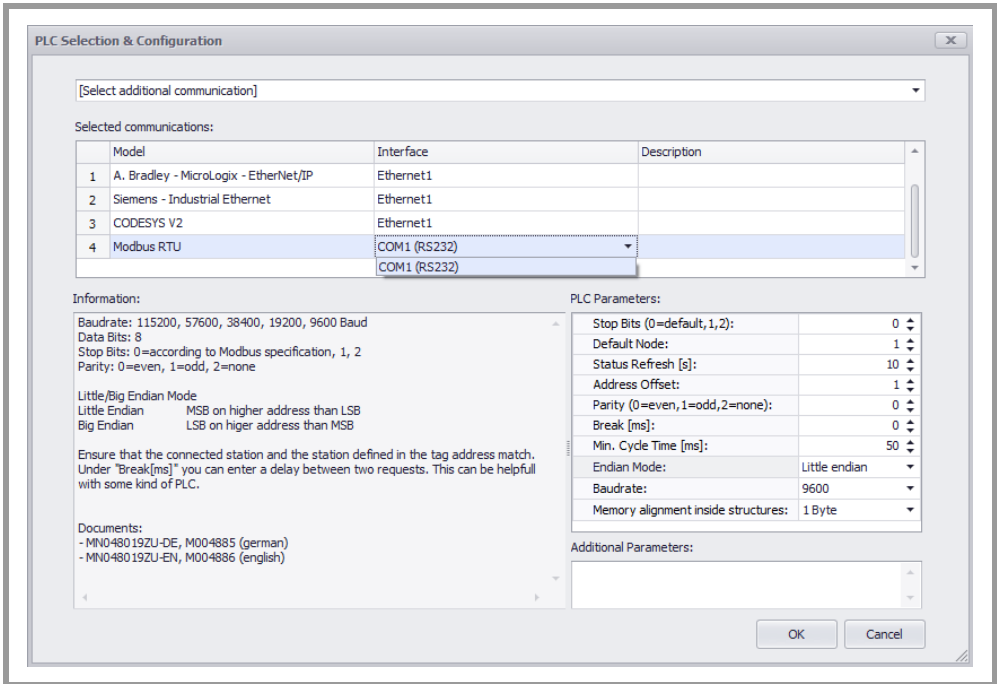

Fig. 40 Selecting the interface

After this, Galileo Runtime will establish an active connection to the PLC, after which you will be able to set a value of your choice for the "TestWord" tag.

## 12 Setting up PLC communication with Galileo

### 12.6 Modbus

Exit Galileo Runtime by clicking on the "X" icon in the upper right corner or using a configured "exit" function, then run it again. If the last value you entered is shown, this means that everything has been configured properly.

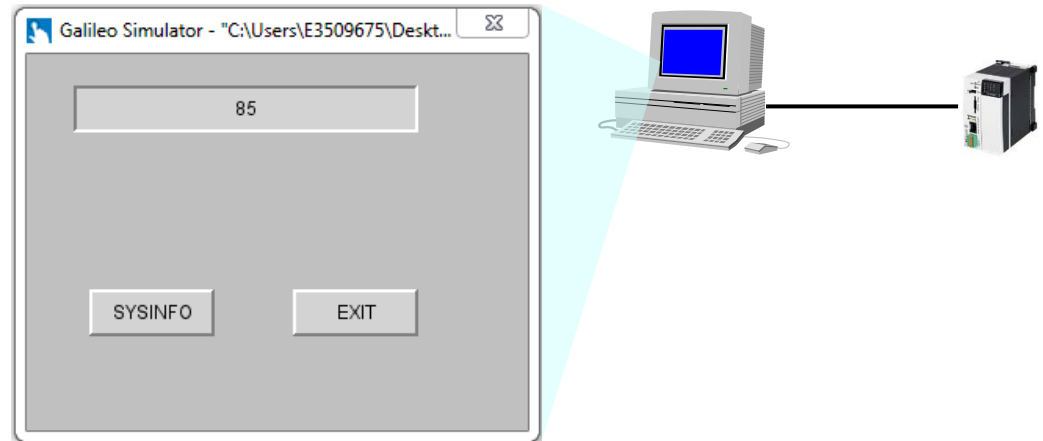

You can now transfer the project to your panel and then restart the panel. For more information, please refer to the documentation for GALILEO.

**Note:**  
The plug and pin assignment for the SYSTEM PORT on the panel are identical to those for the standard RS232 PC interface. You can use the exact same communication cable in this case!

## 12 Setting up PLC communication with Galileo

### 12.7 Wago I/O System

#### 12.7 Wago I/O System

The general requirements from the previous sections apply. The following information only provides specific instructions and settings for the WAGO I/O system.

Eaton Automation does not provide support for the WAGO programming tool. If you have any questions, please contact the developer directly.

##### 12.7.1 Function principle

The type of connection shown below is only supported by programmable WAGO field bus controllers, such as the LON 750-819 coupler shown.

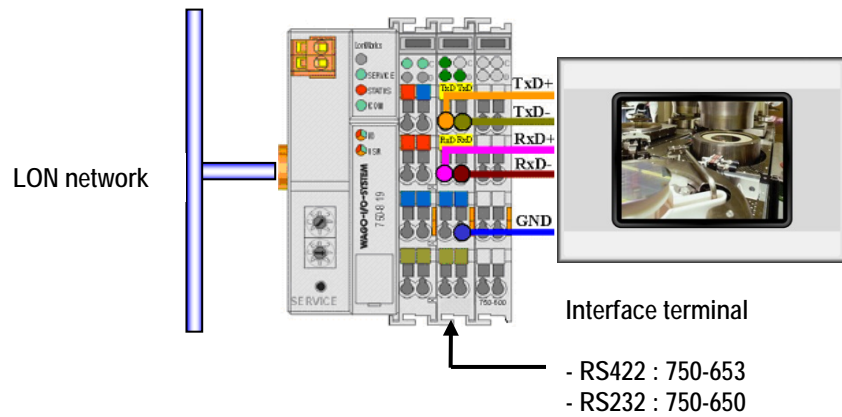

##### 12.7.2 Cable assembly and termination



Panel/PC COM PORT		RS422	WAGO module 750-653	
PIN	SIG		SIG	PIN
2	TxD+		RxD+	2
3	RxD+		TxD+	1
7	TxD-		RxD-	6
8	RxD-		TxD-	5
5	0V		0V	7
CASE	SHIELD		SHIELD	

## 12 Setting up PLC communication with Galileo

### 12.7 Wago I/O System

Panel/PC COM PORT		RS232	WAGO module 750-650	
PIN	SIG		SIG	PIN
2	RxD		TxD	1
3	TxD		RxD	5
5	0V		0V	3
CASE	SHIELD		SHIELD	

### 12.7.3

#### Setting up communication

In the "PLC Selection" dialog box, select a model as follows:

→ SYSTEM PORT: "Modbus RTU":

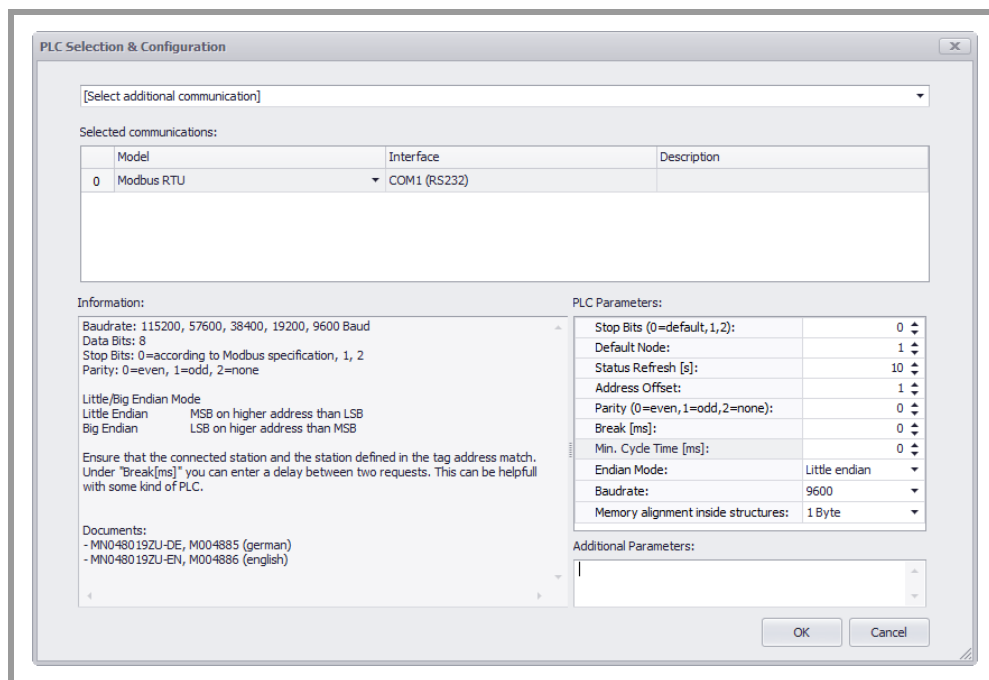

Fig. 41 Configuring communications in GALILEO – Modbus RTU

Configure the parameters as shown in the screenshot above. Observe the notes regarding the "Default Node" parameter.

**Note:**

The "Break [ms]" parameter should be assigned a higher value (+10 ms) than the timeout set on the WAGO function block (TERMINAL\_MODBUS\_SLAVE\_RTU).

For more information, please refer to the WAGO document titled "Connecting an Eaton Automation Touch Panel to a WAGO 750-8xx Controller."

## 12 Setting up PLC communication with Galileo

### 12.7 Wago I/O System

#### 12.7.4

#### Addressing

For Modbus RTU communication with WAGO controllers, the panels support the function codes described below, as well as the corresponding data storage areas.

Modbus register	GALILEO	Function code		Data type	Granularity
		Read	Write		
Coils	M	0x01	0x0F	Bit	16-bits
Registers	R	0x03	0x10	Word	16-bits

GALILEO		Modbus		WAGO Controller		Modbus		GALILEO
M	→	0x0F	→	aDATA[BIT_OFFSET]	→	0x01	→	M
R	→	0x10	→	aDATA[0]	→	0x03	→	R

**Note:**

The WAGO TERMINAL\_MODBUSLAVE\_RTU block defines an ARRAY for a maximum of 256 Modbus registers (aDATA).

The BIT\_OFFSET parameter can be used to define the index in the ARRAY starting from which the coils are stored.

#### 12.7.5

#### Fault messages

If there is a communication malfunction, one of the following system messages may be generated:

System message (Status)	Possible cause
"..... CONNECTION" "..... CABLE"	There is no bus connection or the connection cable was assembled incorrectly.
"..... TIMEOUT"	The PLC is sending an incomplete data stream.
"..... ADDRESS" "..... ILLEGAL DATA ADDRESS"	The requested address is not available on the PLC.
"..... STATION"	The response was not generated by the addressed PLC.
"..... PROTOCOL" "..... ILLEGAL FUNCTION"	The PLC's response does not conform to the Modbus RTU specification, or the Modbus function (function code) is not available.
"..... CHECKSUM?"	The data packet's checksum is incorrect.

## 12.8

## ELC

The GALILEO visualization program supports the use of multiple parallel communication channels. One "controller" will take up one serial interface exclusively.

## 12.8.1

## Setting up communication – ASCII

Select "ELC ASCII" and configure the communication parameters as required.

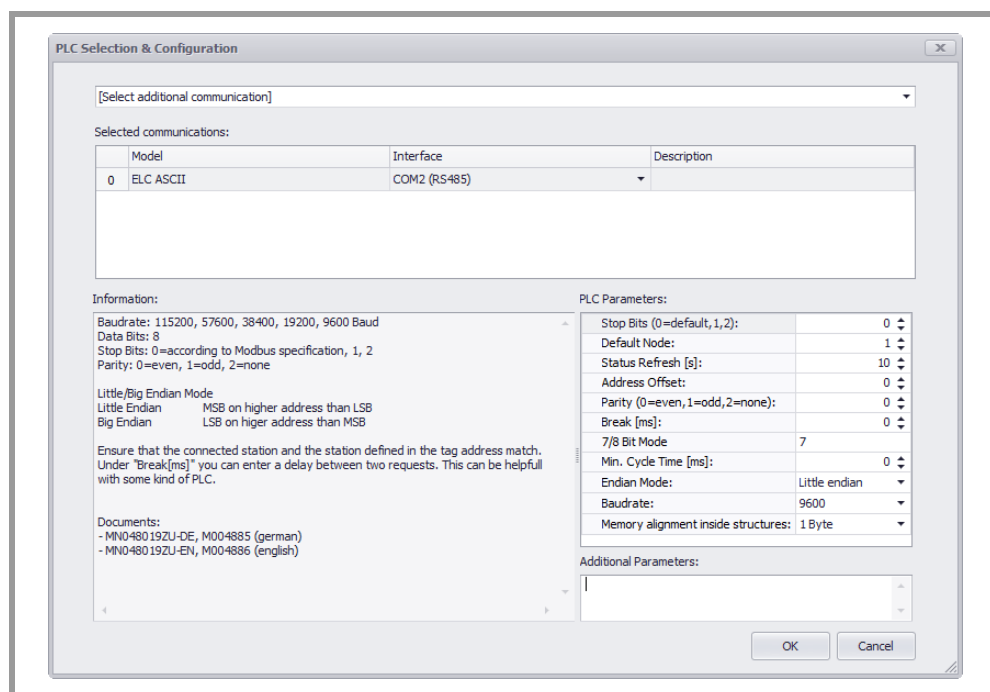

Fig. 42 Configuring communications in GALILEO – ELC ASCII

Communication parameters	Comment								
Stopbits (0=standard,1,2):	Select the right stop bits for your controller. If "0=default" is selected: The stop bit will be automatically selected as per the Modbus standard based on the selected parity.								
	<table border="1"> <thead> <tr> <th>Parity</th> <th>Stop bit</th> </tr> </thead> <tbody> <tr> <td>Flat</td> <td>1</td> </tr> <tr> <td>odd</td> <td>1</td> </tr> <tr> <td>None</td> <td>2</td> </tr> </tbody> </table>	Parity	Stop bit	Flat	1	odd	1	None	2
Parity	Stop bit								
Flat	1								
odd	1								
None	2								
Default Node:	Enter the station number for the default PLC here.								
Status Refresh [s]:	For more information, read the online help for your GALILEO version.								
Address Offset:	As specified in the Modbus RTU specification, the start address of a data packet minus 1 (address offset) will be transferred								

## 12 Setting up PLC communication with Galileo

### 12.8 ELC

	(GALILEO address: 5 = Protocol address: 4). If your PLC does not use this convention, select a value of 0 for this parameter
Parity: (0=even, 1=odd, 2=none)	Select the right parity for your PLC. The default for Modbus RTU is 0 (even parity).
Break [ms]:	Can be used to define a pause generated after an active data transfer with the PLC.
7/8 Bit Mode:	Number of data bits per character
Min. Cycle Time:	
Endian Mode:	This parameter defines how data is organized in the protocol.
Baud Rate:	The baud rates for the "client" and "controller" must be identical.
Memory alignment inside structures:	1 Byte, 2 Byte (Word), 4 Byte (DWord)

Tab. 27 ELC ASCII communication parameters

#### 12.8.2

#### Setting up communication – RTU

Select "ELC RTU" and configure the communication parameters as required.

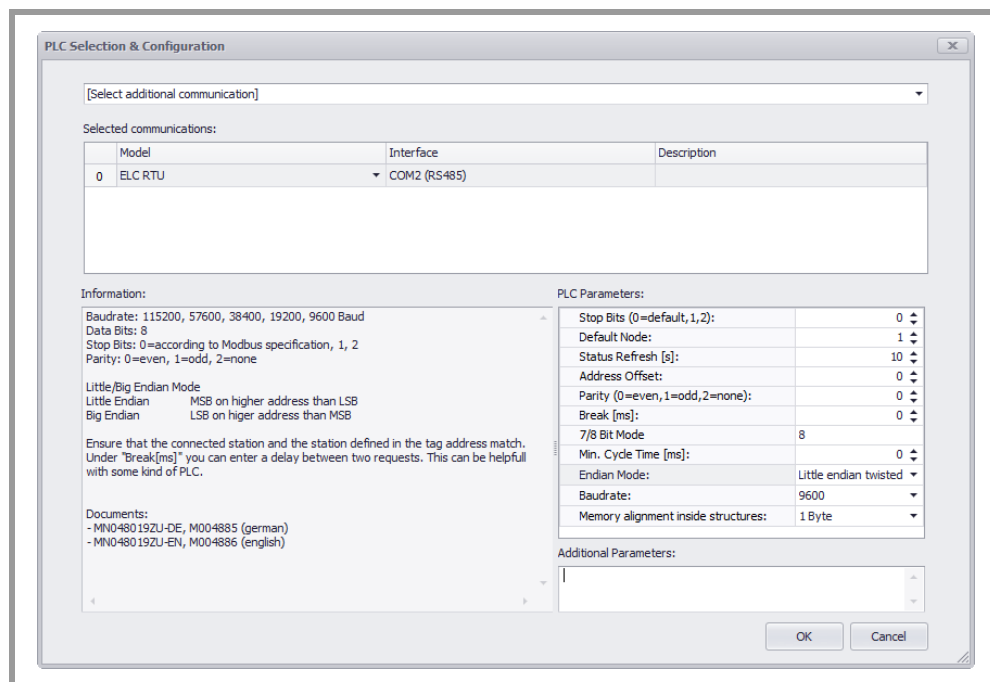

Fig. 43 Configuring communications in GALILEO – ELC RTU

Communication parameters	Comment								
Stop Bits (0=default,1,2):	<p>Select the right stop bits for your controller. If "0=default" is selected: The stop bit will be automatically selected as per the Modbus standard based on the selected parity.</p> <table border="1"> <thead> <tr> <th>Parity</th> <th>Stop bit</th> </tr> </thead> <tbody> <tr> <td>Flat</td> <td>1</td> </tr> <tr> <td>odd</td> <td>1</td> </tr> <tr> <td>None</td> <td>2</td> </tr> </tbody> </table>	Parity	Stop bit	Flat	1	odd	1	None	2
Parity	Stop bit								
Flat	1								
odd	1								
None	2								
Default Node:	Enter the station number for the default PLC here.								
Status Refresh [s]:	For more information, read the online help for your GALILEO version.								
Address Offset:	As specified in the Modbus RTU specification, the start address of a data packet minus 1 (address offset) will be transferred (GALILEO address: 5 = Protocol address: 4). If your PLC does not use this convention, select a value of 0 for this parameter								
Parity: (0=even, 1=odd, 2=none)	Select the right parity for your PLC. The default for Modbus RTU is 0 (even parity).								
Break [ms]:	Can be used to define a pause generated after an active data transfer with the PLC.								
7/8 Bit Mode:	Number of data bits per character								
Min. Cycle Time:									
Endian Mode:	This parameter defines how data is organized in the protocol.								
Baud Rate:	The baud rates for the "client" and "controller" must be identical.								
Memory alignment inside structures:	1 Byte, 2 Byte (Word), 4 Byte (DWord)								

Tab. 28 ELC RTU communication parameters



## 12.8.3

## Setting up communication – TCP

Select "ELC TCP" and configure the communication parameters as required.

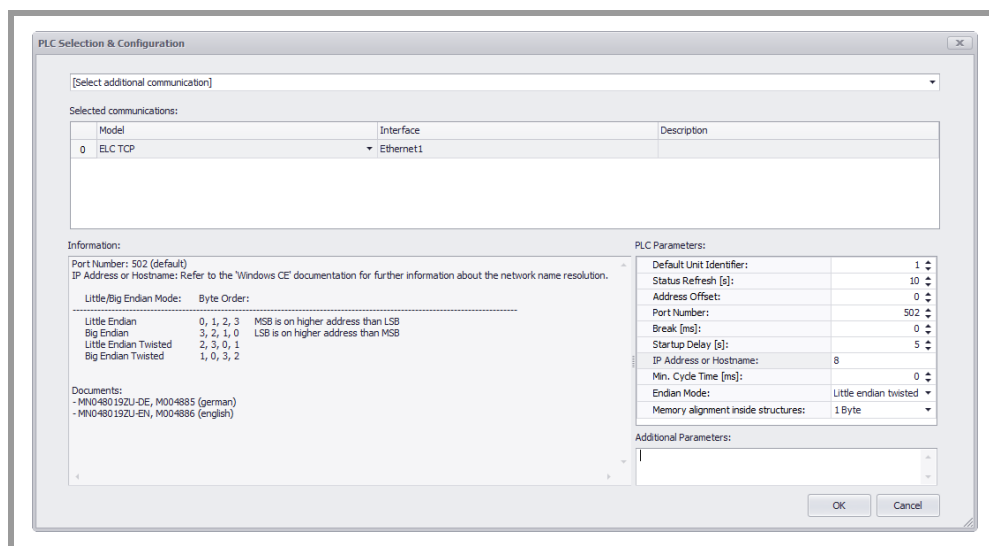

Fig. 44 Configuring communications in GALILEO – ELC TCP

Communication parameters	Comment
Standard Unit Identifier:	Required in order to communicate with target units located behind bridges, routers, or gateways addressed with a single IP address. The "Unit Identifier" identifies the target unit.
Status Refresh [s]:	For more information, read the online help for your GALILEO version.
Address Offset:	As specified in the Modbus RTU specification, the start address of a data packet minus 1 (address offset) will be transferred (GALILEO address: 5 = Protocol address: 4). If your PLC does not use this convention, select a value of 0 for this parameter
Port number	Default port number
Break [ms]:	Can be used to define a pause generated after an active data transfer with the PLC.
Startup Delay [s]	For more information, read the online help for your GALILEO version.
IP Address or Hostname:	IP address or hostname Example: 172.17.103.5
Min. Cycle Time:	
Endian Mode:	This parameter defines how data is organized in the protocol.
Memory alignment inside structures:	1 Byte, 2 Byte (Word), 4 Byte (DWord)

Tab. 29 Communication parameters

12.8.4

Assigning addresses to tags

GALILEO supports the following address formats and data types:

GALILEO	Controller
C%d	Tags on the controller.
D%d	
M%d	
S%d	
T%d	
X%0	
Y%0	

Tab. 30 Address formats in GALILEO

GALILEO	Controller
Bit / Error	C, M, S, T, X, Y
Byte:	not supported
Word	C, D, T
DWord	Cc
Float	not supported
String	not supported
Structure	not supported

Tab. 31 Data types in GALILEO

## 12.9

### Simatic S7

This communication method requires a panel with an MPI interface. For information on the communication cable, please consult the PROFIBUS section in the "Installation Instructions, General Wiring Information" document.

Regardless of the number of connections, there must be 40 available license points on the device.

**Note:**  
If you have any questions concerning license products, please contact your panel distributor.

## 12.9.1

### Setting up communication – Siemens MPI

To be able to use Industrial Ethernet, you will need at least one of the following SIMATIC Manager versions:

- STEP 7 V5.2 + NET driver
- STEP 7 V5.3

For more information on how to set up and configure a SIMATIC network, please refer to the help for SIMATIC Manager / SIMATIC NetPro.

**Note:**  
Before creating a connection to a panel on a SIMATIC S7 PLC, make sure that the SIMATIC S7 PLC can be reached on the network with the SIMATIC PG.

## 12.9.1.1

### Hardware requirements

This communication method requires a panel with an Ethernet interface.

For information on the communication cable, please consult the Ethernet section in the "Installation Instructions, General Wiring Information" document.

Regardless of the number of connections, there must be 40 available license points on the device.

**Note:**  
If you have any questions concerning license products, please contact your panel distributor.

Select "Siemens – MPI" and configure the communication parameters as required.

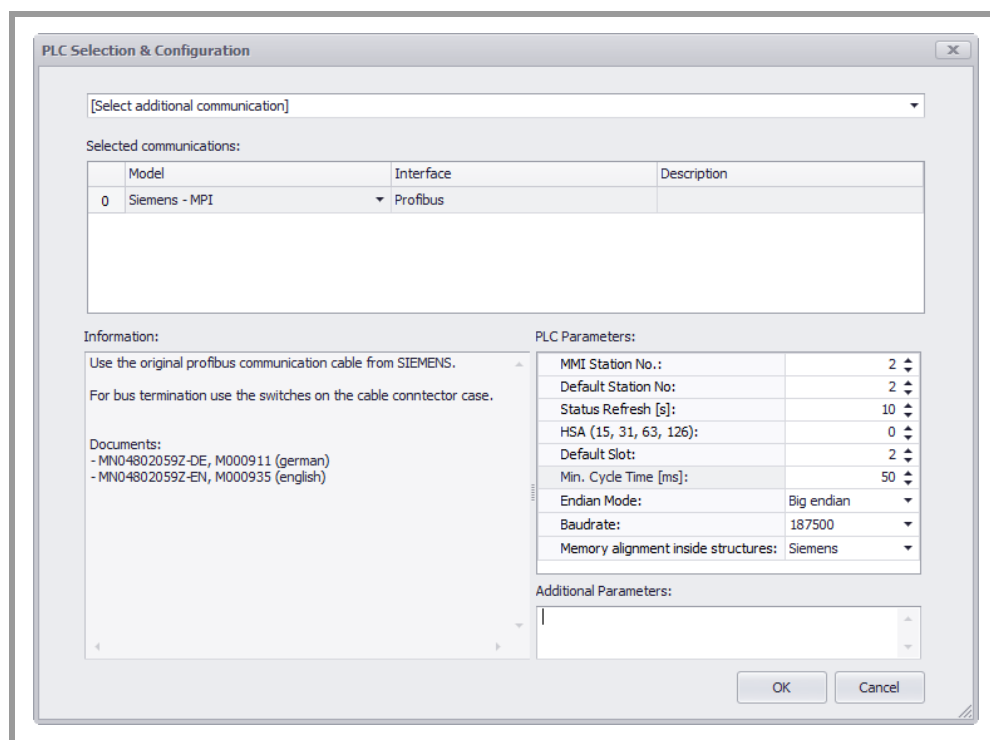

Fig. 45 Configuring communications in GALILEO –Siemens MPI

**Note:**

Galileo supports multiple connections for the interface, i.e., multiple connections can be configured for the same interface. This means that the tags (including the corresponding system structures) on multiple PLCs can be assigned addresses. The baud rate, MMI station number, and HSA for all connections must match.

Select "Siemens – MPI" in the "PLC Selection and Configuration" dialog box. The dialog box shown above will appear so that you can configure the parameters required for the corresponding communication method.

**12.9.1.2****Baud Rate**

187.5 kB and 1.5 MB are supported. The baud rate must match the baud rate setting for the MPI subnet in STEP 7 SIMATIC Manager.

**12.9.1.3****MMI Station No.**

The panel's station number on the MPI network. The number must fall within a range of 1 to HSA. Moreover, it is necessary to make sure that every node on the MPI subnet is assigned a unique MPI address. If necessary, check the information in "Accessible Nodes" using the SIMATIC PG to check which addresses have been assigned already.

## 12.9.1.4

## Highest Station Address (HSA)

The setting specifying the highest MPI address is used to optimize the MPI subnet. This setting must match the setting for the highest MPI address on the MPI subnet in STEP 7 SIMATIC Manager. The following values are valid: 15, 31, 63, and 126.

## 12.9.2

## Setting up communication – Siemens Industrial Ethernet

Select "Siemens – Industrial Ethernet" and configure the communication parameters as required.

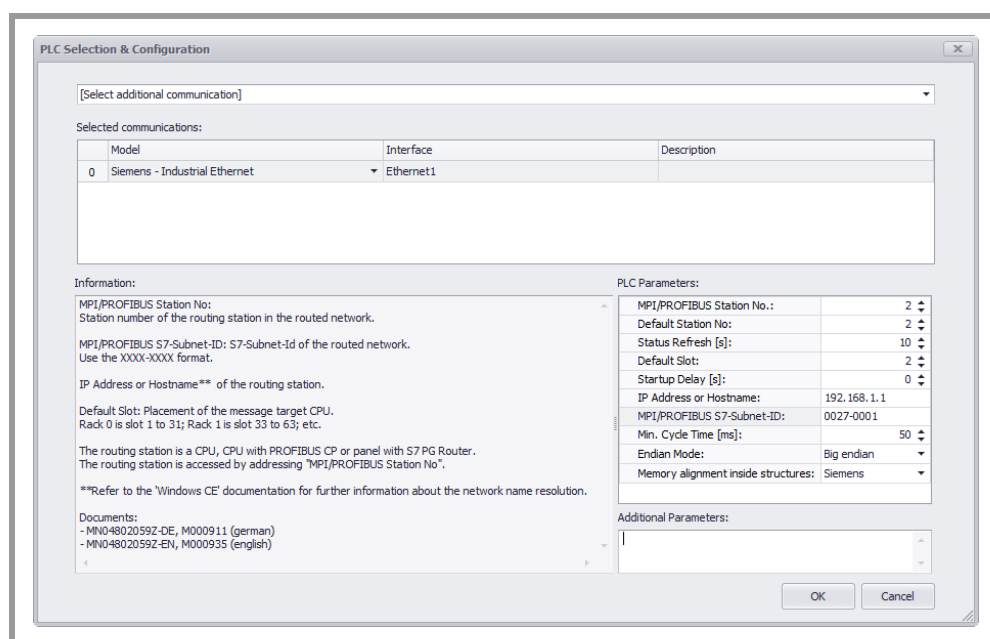

Fig. 46 Configuring communications in GALILEO –Siemens Industrial Ethernet

**Note:**

Galileo supports multiple connections for the Ethernet interface, i.e., multiple connections can be configured for the same port. This means that the tags (including the corresponding system structures) on multiple PLCs can be assigned addresses.

Select "Siemens – Industrial Ethernet" in the "PLC Selection and Configuration" dialog box. The dialog box shown above will appear so that you can configure the parameters required for the corresponding communication method.

## 12.9.3

## Startup Delay

For information on startup delays, please refer to the online help for Galileo.

12.9.4

**MPI/PROFIBUS Station No.**

Used to enter the station number of the node defined as a router on the MPI/PROFIBUS subnet. This node can be a panel or a SIMATIC S7 station.

In the following example, in which communication takes place via a SIMATIC S7 station used as a router, station number **31** would be entered for communication with stations **2** and **31**.

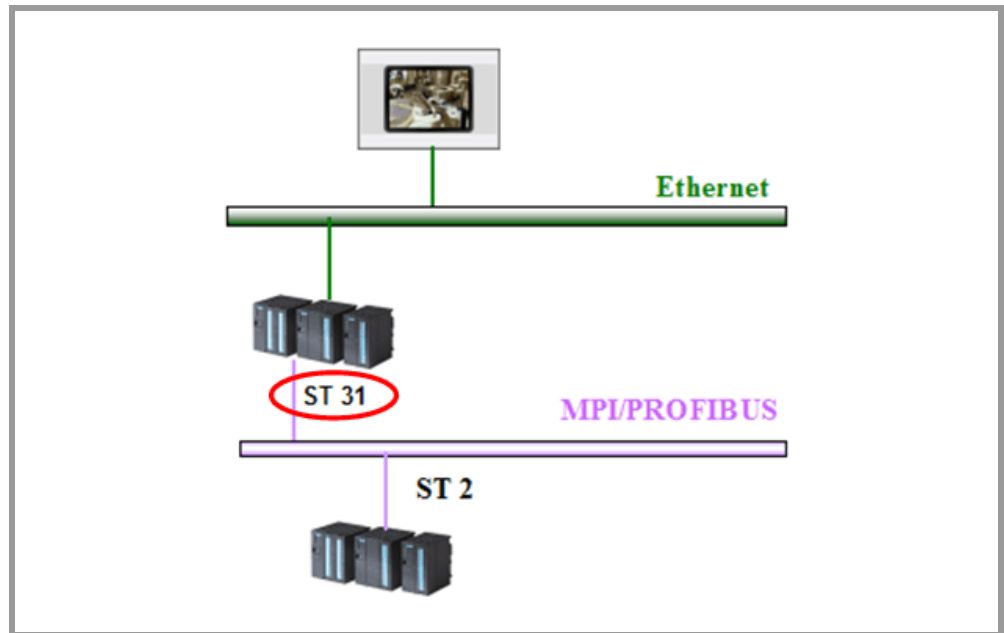

Fig. 47 Station numbers – Stations 2 and 31

In the following example, in which communication takes place via a panel used as a router, station number **31** would be entered for communication with station **2**.

12 Setting up PLC communication with Galileo  
12.9 Simatic S7

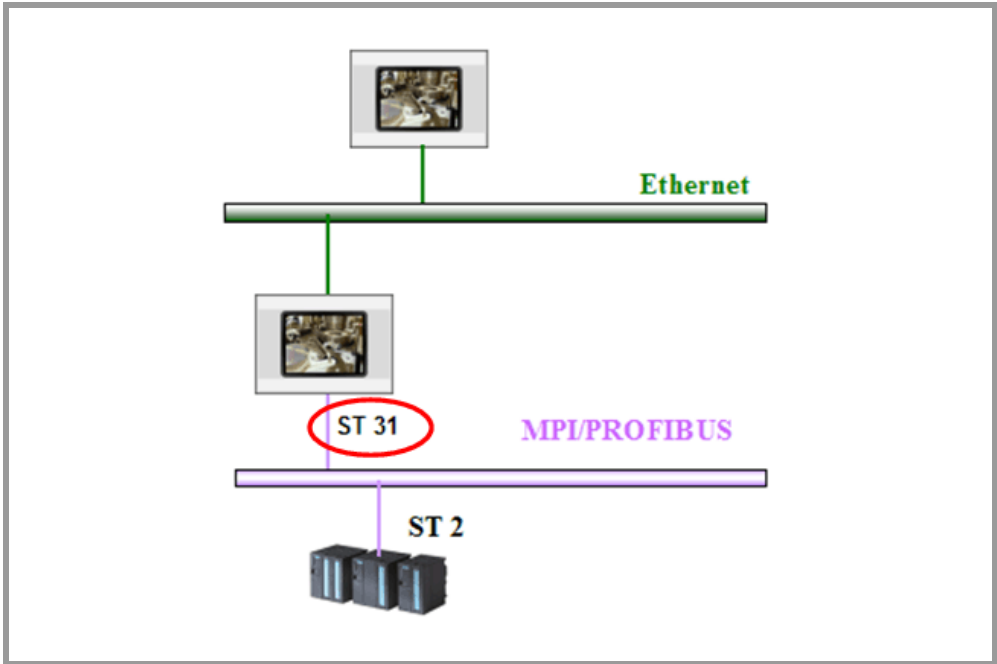

Fig. 48 Station numbers – Station 2 and panel 31

In the following example, in which a PLC is connected directly to the Ethernet network, 5 would be entered for communication with station number 5.

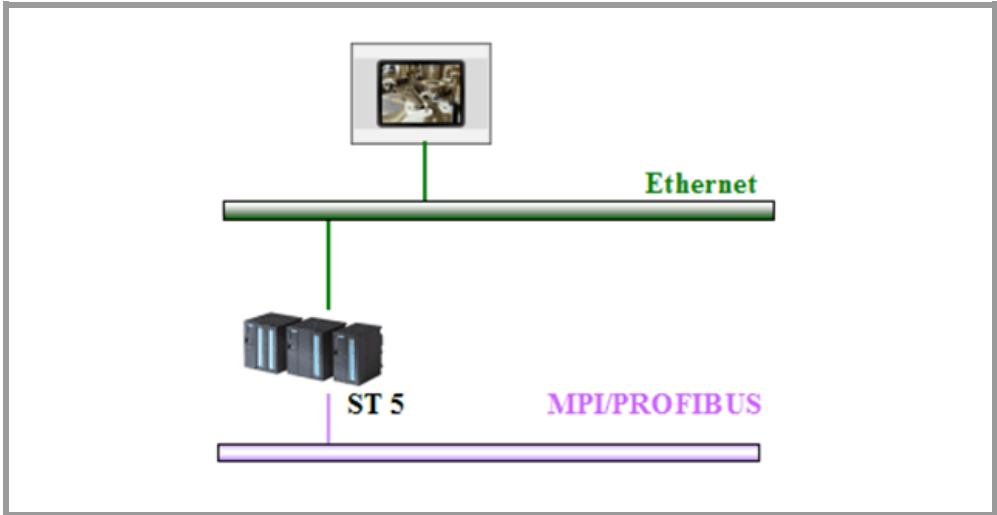

Fig. 49 Station number – Station 5

12.9.5

MPI/PROFIBUS S7-Subnet-ID

An MPI/PROFIBUS S7 subnet ID only needs to be entered if a PLC on the MPI/PROFIBUS subnet is being accessed via a router. In the following example, this would be required for station number 2. A subnet ID does not have to be entered if the PLC can be accessed directly via the Ethernet network. The MPI/PROFIBUS S7 subnet ID must be taken from the SIMATIC network configuration, and should not be confused with the Ethernet S7 subnet ID.

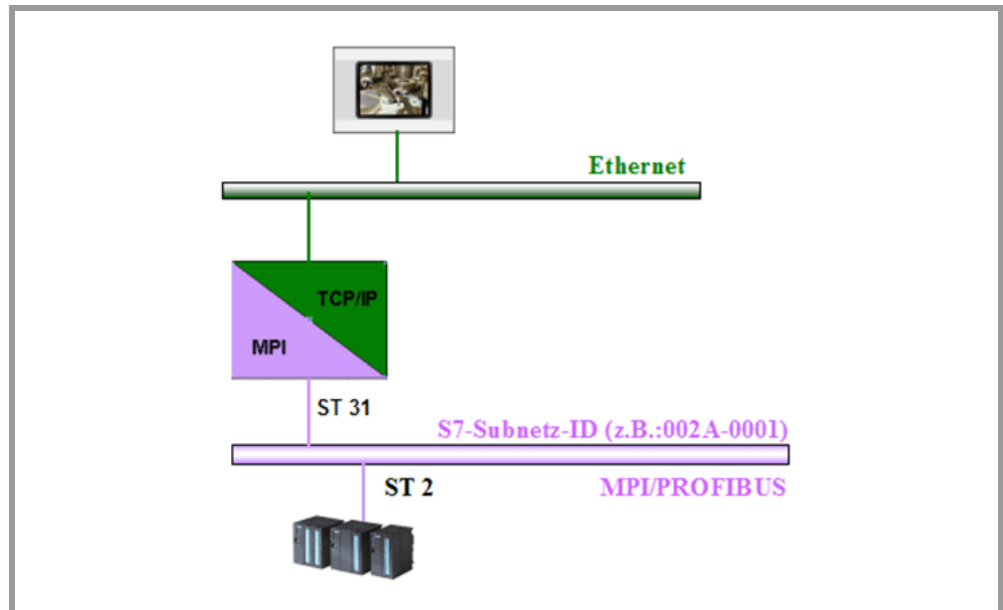

Fig. 50 MPI/PROFIBUS S7 – Subnet ID

12.9.6

IP Address

The IP address must match the setting for the SIMATIC station or panel with the PG router function. This setting will be the router's / node's IP address on the Ethernet network.

In the following example, two connections would need to be configured:

1. **192.168.0.39** would be entered for the connection to station numbers 2 and 31.
2. **192.168.0.40** would be entered for the connection to station number 5.



12 Setting up PLC communication with Galileo  
 12.9 Simatic S7

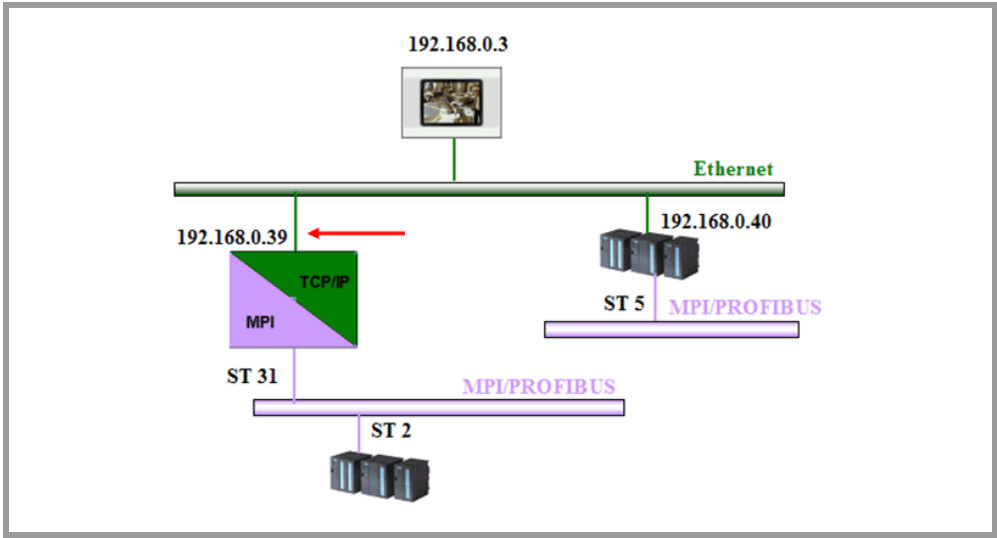

Fig. 51 IP Address

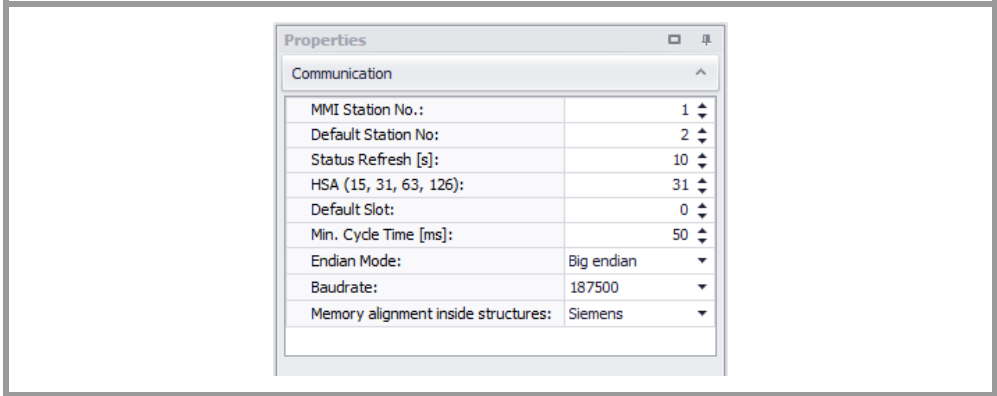

Fig. 52 Industrial Ethernet – IP address

**Note:**  
 The subnet mask for the panel must match the subnet mask for the SIMATIC S7 station. For more information on how to set the panel's IP address, please refer to "Windows CE System Description."

## 12.10 Siemens – S7 Profibus Standard Profile

### 12.10.1 General

To be able to use this communication method, you will need a SIMATIC CPU/CP that supports S7 communication at least as a slave via PROFIBUS.

A panel will take up at least one OP connection.

For more information on how to set up and configure a SIMATIC network, please refer to the help for SIMATIC Manager / SIMATIC NetPro.

### 12.10.2 Hardware requirements

This communication method requires a panel with an MPI/DP interface. For information on the communication cable, please consult the PROFIBUS section in the "System Description – Networks in Brief" document.

Regardless of the number of connections, there must be 40 available license points on the device.

**Note:**  
If you have any questions concerning license products, please contact your panel distributor.

### 12.10.3 SIMATIC network settings

The standard profile must be selected under "Profile." When using this profile, the "Options..." button can be used to take into account additional nodes, that cannot be configured with STEP 7, when calculating the relevant bus parameters.

**Note:**  
If you cannot run the PROFIBUS bus with the bus parameters for the standard profile, please contact our Support staff.

## 12 Setting up PLC communication with Galileo

### 12.10 Siemens – S7 Profibus Standard Profile

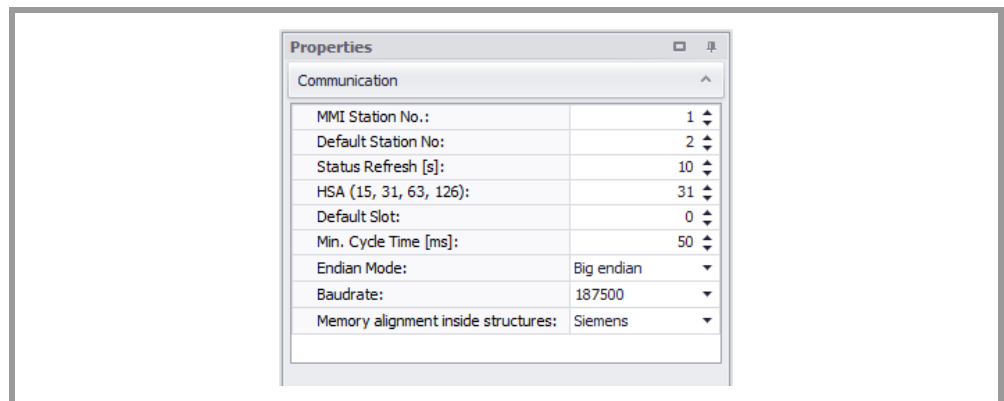

Fig. 53 MPI Profibus – Network settings

Exactly one active node with an S7 communication load must be added for each panel. The percentage of the total bus load must be selected as "low."

#### 12.10.4

#### Setting up communication – Siemens S7 Profibus Standard Profile

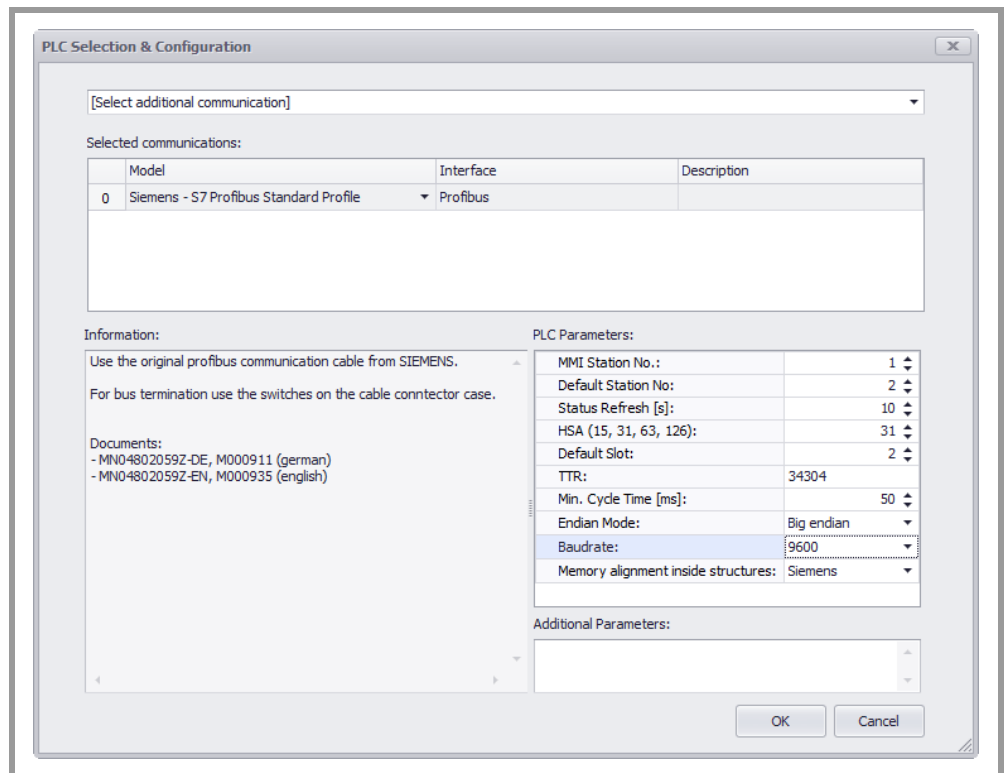

Fig. 54 PLC Selection and Configuration - Siemens S7 Profibus Standard Profile

## 12 Setting up PLC communication with Galileo

### 12.10 Siemens – S7 Profibus Standard Profile

**Note:**

Galileo supports multiple connections for the interface, i.e., multiple connections can be configured for the same interface. This means that the tags (including the corresponding system structures) on multiple PLCs can be assigned addresses. The baud rate, MMI station number, and HSA, and TTR for all connections must match.

Select "Siemens – 7 Profibus Standard Profile" in the "PLC Selection and Configuration" dialog box. The dialog box shown above will appear so that you can configure the parameters required for the corresponding communication method.

#### 12.10.4.1

##### Baud Rate

9.6 kB, 19.2 kB, 45.45 kB, 93.75 kB, 187.5 kB, 500 kB, and 1.5 MB are supported. The baud rate must match the baud rate setting for the PROFIBUS network in STEP 7 SIMATIC Manager.

The 45.45 kB baud rate is intended for segment couplers and links to PROFIBUS-PA.

#### 12.10.4.2

##### Station Number

The panel's station number on the PROFIBUS network. The number must fall within a range of 1 to HSA. Moreover, it is necessary to make sure that every node on the PROFIBUS subnet is assigned a unique PROFIBUS address.

#### 12.10.4.3

##### Highest Station Address (HAS)

The setting specifying the highest PROFIBUS address is used to optimize the PROFIBUS subnet. This setting must match the setting for the highest PROFIBUS address on the PROFIBUS subnet in STEP 7 SIMATIC Manager. The following values are valid: 15, 31, 63, and 126.

#### 12.10.4.4

##### Target Rotation Time (TTR)

The TTR in t<sub>Bit</sub> is calculated in the STEP 7 network configuration and must be copied accordingly. Please note that changes to the SIMATIC network settings may affect the TTR.

#### 12.10.5

##### Fault messages

If there is a communication error, a variety of system fault messages may be generated. In turn, these system fault messages provide a variety of information:

- The address, followed by the block size in bytes, specifies the tag or tag blocks on which the error has occurred.
- The communication name corresponds to the "Description" field in the "PLC Selection and Configuration" dialog box, and is used to identify the communication channel on which a problem has occurred.
- The station number after ST# is the MPI address for the affected PLC (CPU).
- The additional information may point out a potential error cause using cleartext. However, this information may also be generated by deeper software layers. In other words, users who are not extensively familiar with the system may not be able to always interpret the contents of this additional information. Regardless, the troubleshooting procedure will remain the same in all cases.

## 12 Setting up PLC communication with Galileo

### 12.10 Siemens – S7 Profibus Standard Profile

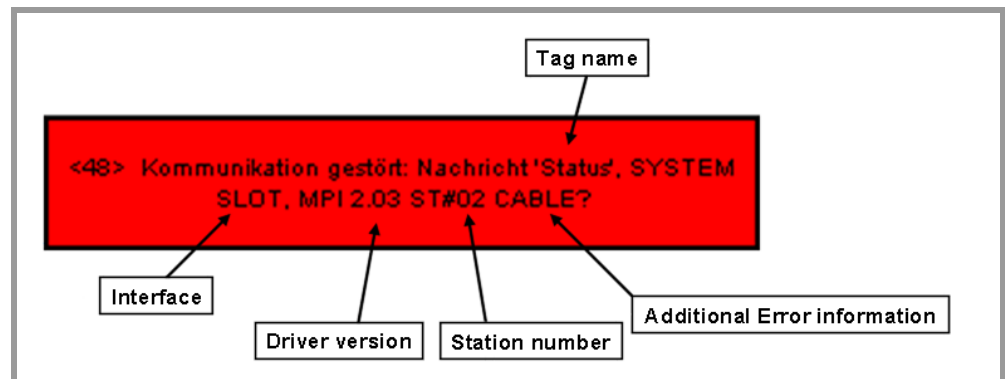

Fig. 55 SIMATIC S7 - Fault messages

#### 12.10.6

#### Bug Fix

We recommend checking the following:

- Check the wiring and connections on the panel and PLC.
- Check the baud rate, HSA, and TTR settings. These settings must be the same for all nodes. Check all other parameters in the "PLC Selection..." dialog box.
- Check the MPI/PROFIBUS addresses on the network. Is the station number shown in the system error message present and reachable on the MPI/PROFIBUS network? Each address must only be found once on the network.
- Does the address for the tag shown in the system fault message exist in the corresponding station? (Has the corresponding DB been created?)
- Are Ethernet communications overloaded?
- Can the PLC (CPU) be reached with the SIMATIC PG?
- Can the PLC (CPU) be reached with a ping command via Ethernet?

If the problem continues, please contact our Customer Support staff at [automation@eaton.com](mailto:automation@eaton.com).

## 12.11 SIMATIC S7 / 200 PPI

## 12.11.1 Setting up communication – SIMATIC S7 / 200 PPI

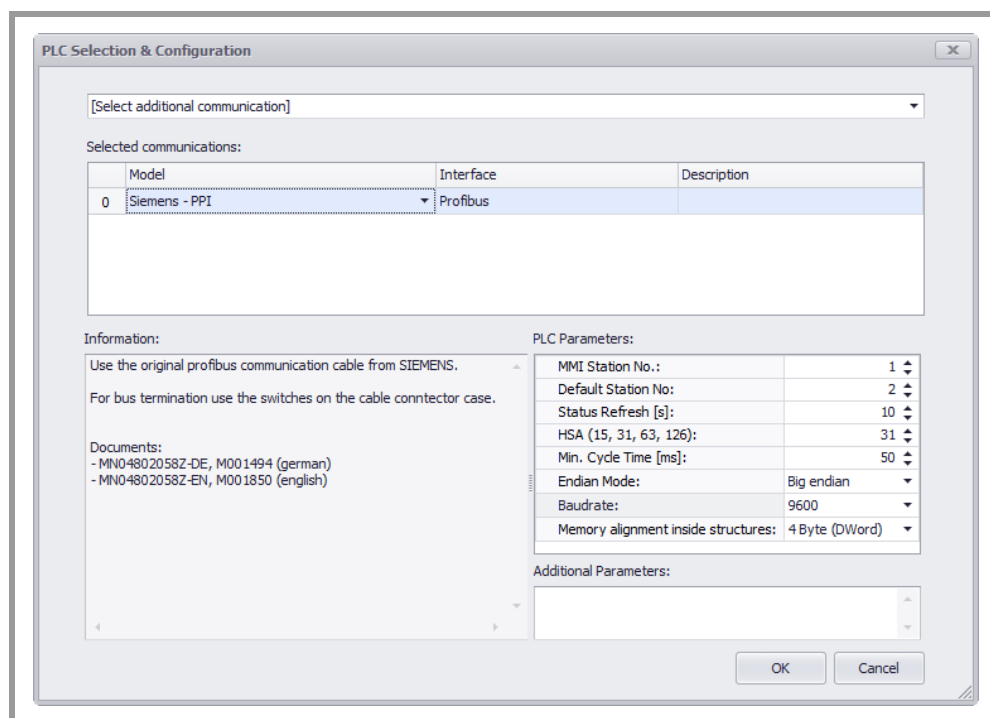

Fig. 56 PLC Selection and Configuration – SIMATIC S7 / 200 PPI

## 12.11.1.1 Baud Rate

9.6 kB, 19.2 kB, and 187.5 kB are supported. The baud rate must match the baud rate setting for all stations on the network.

## 12.11.1.2 Highest Station Address (HAS)

The setting specifying the highest station address is used to optimize the PROFIBUS network. This setting must match the setting for the highest station address on the subnet in STEP 7-Micro/WIN in the CPU configuration for a CPU interface. The following values are valid: 15, 31, 63, and 126.

## 12.11.1.3 Status Refresh

Please refer to the Galileo online help.

## 12.11.1.4 MMI Station No.

The panel's station number on the PROFIBUS network. The number must fall within a range of 1 to HSA. Moreover, it is necessary to make sure that every node is assigned a unique address.

## 12 Setting up PLC communication with Galileo

### 12.11 SIMATIC S7 / 200 PPI

If necessary, check in "Communication" on the PG to see which addresses have already been assigned.

#### 12.11.1.5

#### Default Station No.

See addressing.

#### 12.11.2

#### Fault messages

If there is a communication error, a variety of system fault messages may be generated. In turn, these system fault messages provide a variety of information:

- The address, followed by the block size in bytes, specifies the tag or tag blocks on which the error has occurred.
- The communication name corresponds to the "Description" field in the "PLC Selection and Configuration" dialog box, and is used to identify the communication channel on which a problem has occurred.
- The station number after ST# is the address for the affected PLC (CPU).
- The additional information may point out a potential error cause using cleartext. However, this information may also be generated by deeper software layers. In other words, users who are not extensively familiar with the system may not be able to always interpret the contents of this additional information. Regardless, the troubleshooting procedure will remain the same in all cases.

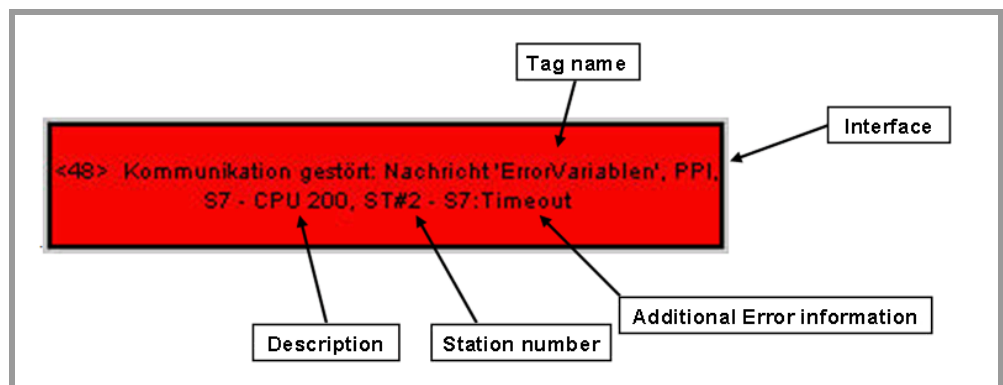

Fig. 57 SIMATIC S7 / 200 PPI - Fault messages

#### 12.11.3

#### Bug Fix

We recommend checking the following:

- Check the wiring and connections on the panel and PLC.
- Check the baud rate and HSA settings. These settings must be identical on all nodes.
- Check the station addresses on the network. Is the station number shown in the system fault message present and reachable on the PROFIBUS network? Each address must only be found once on the network.

## 12 Setting up PLC communication with Galileo

### 12.11 SIMATIC S7 / 200 PPI

- Does the address for the tag shown in the system fault message exist in the corresponding station?
- Are communications overloaded?
- Can the PLC (CPU) be reached with the PG?

If the problem continues, please contact our Customer Support staff at [automation@eaton.com](mailto:automation@eaton.com).



13

Fault messages

