

Green Motion DC 22 User manual



DISCLAIMER OF WARRANTIES AND LIMITATION OF LIABILITY

The information, recommendations, descriptions and safety notations in this document are based on Eaton Corporation's ("Eaton") experience and judgment and may not cover all contingencies. If further information is required, an Eaton sales office should be consulted. Sale of the product shown in this literature is subject to the terms and conditions outlined in appropriate Eaton selling policies or other contractual agreement between Eaton and the purchaser.

THERE ARE NO UNDERSTANDINGS, AGREEMENTS, WARRANTIES, EXPRESSED OR IMPLIED, INCLUDING WARRANTIES OF FITNESS FOR A PARTICULAR PURPOSE OR MERCHANTABILITY, OTHER THAN THOSE SPECIFICALLY SET OUT IN ANY EXISTING CONTRACT BETWEEN THE PARTIES. ANY SUCH CONTRACT STATES THE ENTIRE OBLIGATION OF EATON. THE CONTENTS OF THIS DOCUMENT SHALL NOT BECOME PART OF OR MODIFY ANY CONTRACT BETWEEN THE PARTIES.

In no event will Eaton be responsible to the purchaser or user in contract, in tort (including negligence), strict liability or other-wise for any special, indirect, incidental or consequential damage or loss whatsoever, including but not limited to damage or loss of use of equipment, plant or power system, cost of capital, loss of power, additional expenses in the use of existing power facilities, or claims against the purchaser or user by its customers resulting from the use of the information, recommendations and descriptions contained herein. The information contained in this manual is subject to change without notice.

Content overview

1	INTRODUCTION.....	4
	1.1 Scope of the document.....	5
	1.2 Symbols used in this manual.....	5
2	CAUTIONS.....	6
	2.1 Operating environment and restrictions	6
3	DISCOVER YOUR GREEN MOTION DC 22 EV charger	7
	3.1 Checking the box contents	7
	3.2 Front and back views	7
	3.3 Bottom view	8
	3.4 Type of cables	8
4	HOW TO START AND STOP CHARGING.....	9
5	INDICATORS AND USER INTERFACES	10
	5.1 LED indicators.....	10
	5.2 Color touchscreen display.....	11
	5.3 Emergency stop button	13
6	SOFTWARE SUITE.....	13
7	MAINTENANCE	14
	7.1 How to put the unit as out of order	14
	7.2 Station updates	14
	7.3 Cleaning or replacing filters	14
	7.4 Disposal.....	15
8	FREQUENTLY ASKED QUESTIONS	15
9	TECHNICAL DATA.....	16
	9.1 Rating plate.....	16
	9.2 Technical datasheet.....	16
10	CONTACT SUPPORT INFORMATION	17

1. Introduction

Thank you for purchasing the Green Motion DC 22 EV charger. Green Motion DC 22 is an electric vehicle fast charging station for everyone. It offers fast charging speed at high efficiency with a compact design and it can be fixed to a wall or floor-mounted as an option, for indoor or outdoor use.

Before you start

This manual contains important instructions that must be followed during the installation, operation and maintenance of the Green Motion DC 22 EV charger. All instructions must be read before installing and operating the equipment. This manual should be retained for future reference. Please note that the Green Motion DC 22 EV charger must only be installed by professional and qualified personnel, i.e. an Eaton technical support representative or a professional installer. There are no user serviceable parts inside the Green Motion DC 22 EV charger. Failure to observe the above will void the guarantee provided and Eaton cannot be held legally accountable.

The contents of this manual are the copyright of the publisher and may not be reproduced (even in extracts) without the prior written approval of Eaton. While every care has been taken to ensure the accuracy of the information contained in this manual, Eaton assumes no liability for any error or omission. Eaton reserves the right to modify the designs of its products. The unauthorized copying and lending of this manual is prohibited.

Technical disclaimer

All drawings, descriptions or illustrations contained in this document serve to provide a clear overview and/or technical explanation of the present product and its various components and accessories. In line with our goal to continuously improve the products and the customer service we provide, all specifications contained in this document are subject to change without notice.

Legal entity

Eaton Industries Manufacturing GmbH

Address: Place de la Gare 2
1345 Le Lieu
SWITZERLAND

Web: www.eaton.com

1.1 Scope of the document

This manual is intended for end-users of Green Motion DC 22 EV charger. It describes the operating environment, the product and its operating behavior. The document does not cover installation and uninstallation, commissioning guidance and troubleshooting.

1.2 Symbols used in this manual



Imminent dangers causing serious injuries. Danger of death.



Hazardous behaviors that could cause serious injuries.

Hazardous behaviors that could cause death.



Behaviors that could cause minor injuries to people or minor damages to things.



An electric shock can be fatal.

Avoid touching internal or external parts normally live while the system is powered on.



The notes preceded by this symbol relate to technical issues and ease of operation.



The EU Directive on Waste Electrical and Electronic Equipment (WEEE).

2. Cautions



Before carrying out any operations, ensure you have read and understood this manual. Do not make changes and do not carry out maintenance operations not described in this manual. The manufacturer does not accept responsibility for injuries to people and damages to things occurred if the information within this manual has not been read and followed.



The installation, commissioning, maintenance or retrofitting must be carried out only by professional and qualified personnel.



It is strictly prohibited to open the EV charger.

2.1 Operating environment and restrictions

Each system must be used exclusively for the operations it was designed for and within the operative ranges specified in the nameplate and/or in the relative technical datasheet, in accordance with the national and international safety standards.

Any use different from the intended use specified by the manufacturer is to be considered totally inappropriate and dangerous and in this case the manufacturer declines all responsibility.



Check the regulations applied by the electricity provider.

The unit can be connected to the distribution network in accordance with local rules.

The unit should only be used in accordance with the technical specifications.



Improper or unauthorized use:

Although carefully constructed, like all electrical appliances the unit can catch fire.

The unit is intended for indoor or outdoor installation.

Recommended operating temperature range of the unit is -25 °C to +45 °C

The unit must be transported and stored in indoor locations in the temperature range -25 °C to +45 °C.

The unit must be used in locations free from acids, gases or other corrosive substances.

The unit must be used and stored in locations with relative humidity below 95 %.

The unit must be transported in conditions with relative humidity below 95 %.

The unit must be used at altitude not exceeding 2000 m above sea level.

3. Discover your Green Motion DC 22 EV charger

3.1 Checking the box contents

The Green Motion DC 22 EV charger box should contain the following parts:

- EV Charger
- Quick start guide,
- Safety guidelines
- EV cable(s), depending on customer configuration:
 - CCS plug, cable, plug holder,
 - CCS and CHAdeMO plugs, cables, plug holders,
- Screws, cable glands and cable gland cap,
- Wall-mount gaskets (four pieces)

3.2 Front and back views

Green Motion DC 22 EV charger is designed for seamless use.

Figure 1. Front and back views of Green Motion DC 22 EV charger

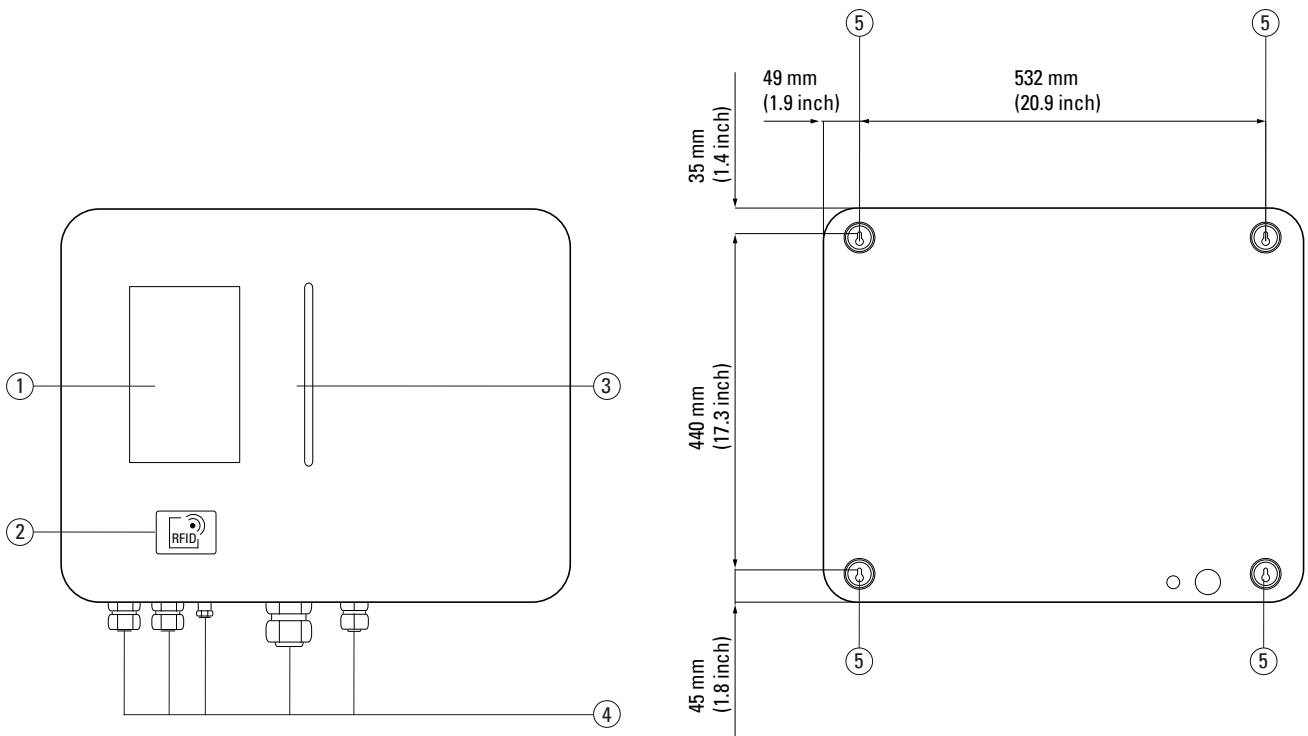

Tag	Description
①	Color touchscreen display
②	RFID reader
③	LED indicator
④	Cable glands
⑤	Mounting holes

3.3 Bottom view

Figure 2. Bottom view of Green Motion DC 22 EV charger

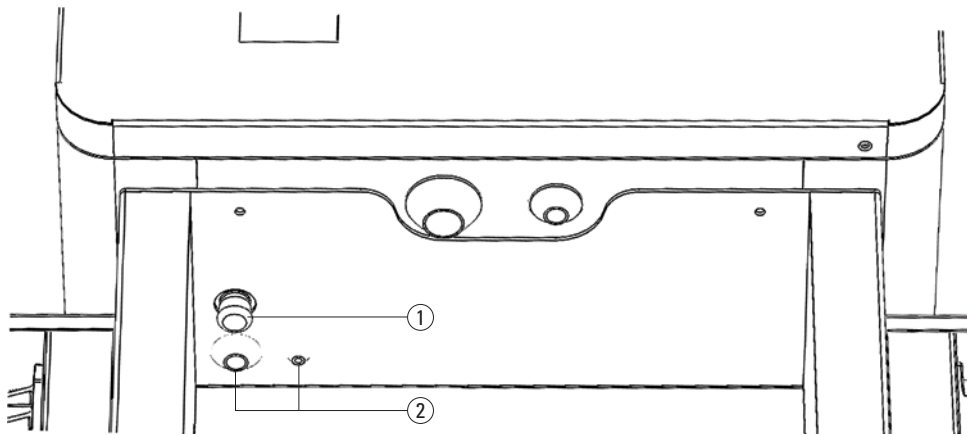

Tag	Description
①	Emergency stop button
②	Cable glands

3.4 Type of cables

Green Motion DC 22 EV charger provides two types of cables and connectors:

1. Cable Combined Charging System (CCS) for the EU market. This is the default cable.
2. CHAdeMO. This cable is optional.

The maximum power that Green Motion DC 22 EV charger can deliver is 22 kW. The instantaneous charging power can vary upon other variables such as grid power available, installation and car model. For those reasons, Eaton declines any responsibility on the actual power value delivered.

Figure 3. Illustration of connector types available with Green Motion DC 22 EV charger

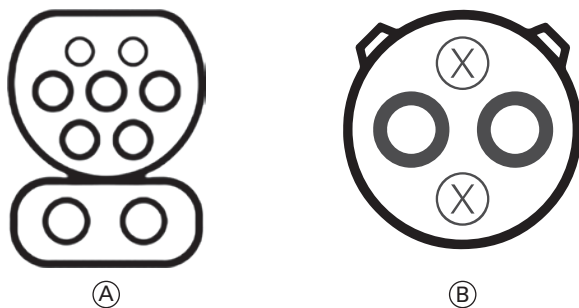

Tag	Description
Ⓐ	CCS Type 2
Ⓑ	CHAdeMO

The unit can be equipped with either CCS or both as reported in the table below.

Table 1. Possible cable configurations available with the charger

Green Motion DC 22 EV charger Cable Options	CCS	CHAdeMO
Default configuration	X	
CCS and CHAdeMO	X	X

4. How to start and stop charging



Electrical systems or devices must be checked by the installer of the system before commissioning and switching on the unit for the first time.

Follow these steps to charge:

- Step 1.** Check that the EV charger is ready for use with the LED in green. See Chapter 5.
- Step 2.** Hold the cable connector of the EV charger and plug it to the appropriate car socket.
- Step 3.** Place the RFID card close to the reader to authenticate yourself.

If the card is recognized, the LED starts flashing blue and after it shows the level of state of charge (see Figure 4).

If the CHAdeMO plug is used, this is mandatory for the user to select the plug on the screen. Refer to the next sections.

If the card is not authorized, the charge will not start, and a red indication is displayed on the charging station display. See Chapter 5.

If the charging cable is disconnected from the car and there is no power consumption within two minutes, the user is automatically deauthenticated.

Figure 4. Where to place the RFID card on the EV charger for user authentication

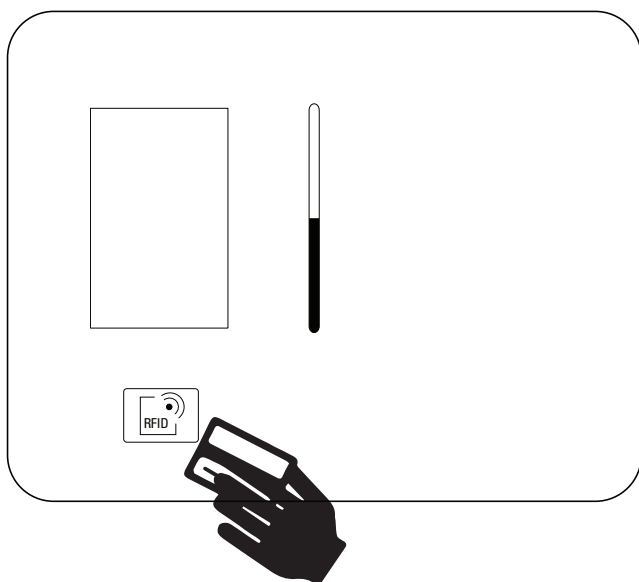

While your vehicle is charging, the EV charger display shows the LED as charging with a breathing blue light. See Chapter 5.

When the battery is fully charged, the EV charger display shows the LED in a steady blue light as fully charged. See Chapter 5.

- Step 4.** To stop charging, unplug the connector from your vehicle. Usually, the connector must be released from inside your vehicle first. See the instruction manual of your vehicle.

5. Indicators and User interfaces

The EV charger has three indicator and user interface means, as shown in Chapter 3:

- LED indicators,
- Color touchscreen display,
- Emergency stop button.

5.1 LED indicators

The EV charger is equipped with a LED indicator located on the front door. See Figure 1. Table 2 summarizes the possible colors of the LED indicator during the operation.

Table 2. LED indicators of the Green Motion DC 22 EV charger

Visual indicator	Description	Status
	Green light on	Ready for use
	Flashing green light	Start-up stage
	Breathing green light	Waiting for user interaction
	Flashing blue light	Charge start-up stage
	Breathing blue light	Vehicle in charge
	Blue light on	Vehicle charged
	Red light on	Error in charging
	Orange pulse	An update is in progress
	White + red dot flashing	Network Error. EV charger cannot connect to the internet/backend
	Yellow light on	Charger is set to unavailable
	No light	Stopped or not powered

During the charge, the LED indicator also shows the state of charge of the vehicle, as per Figure 5.

Figure 5. LED indicator of the state of charge

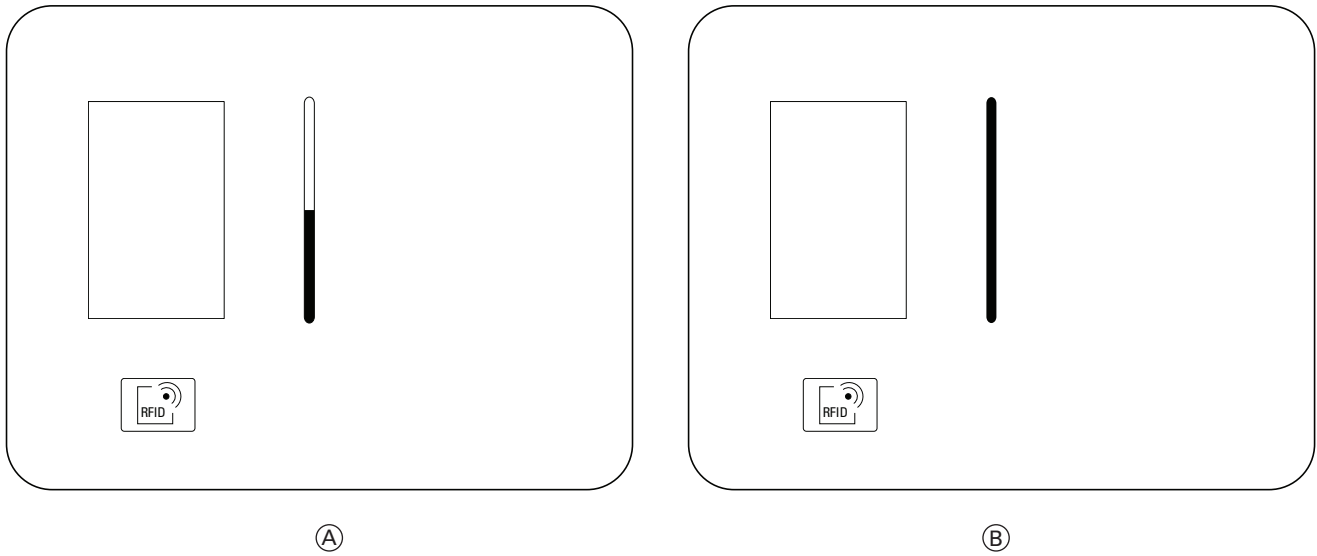







Tag	Description
(A)	50 % charge of the vehicle
(B)	100 % charge of the vehicle

5.2 Color touchscreen display

Green Motion DC 22 EV charger is equipped with a color touchscreen display located on the front door. See Figure 1. Table 3 provides an example of the screens at startup phase. Due to continuous improvement, it is possible that changes will be implemented in the future to enhance the user experience.

Table 3. Examples of information available from the color touchscreen display

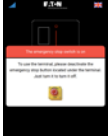
Display	Description
	Touchscreen display. Touch the screen to wake up.
	Authentication screen. Before any operation, ensure that the 4G sign is colored in blue. If the bar graph is RED, there is no connection to the server. Choose your language by touching the flag. Present the RFID badge on the RFID reader to initiate authentication. See Figure 3.
	Select appropriate plug.
	State of charge of the vehicle.

Display	Description
	<p>This charger is not part of your eMSP and you do not have roaming rights. You can not charge with your RFID card. If available use Scan & Charge.</p>
	<p>Authentication failed due to network issues. Try again. Check that the 4G sign is colored in blue.</p>
	<p>Charger is out of order. Maintenance is needed before putting the charger back in service.</p>
	<p>Contact the technical support to put the charger in service.</p>
	<p>Charging station is already booked by a user. If you are not the one who booked it you cannot start charging.</p>
	<p>Unplug and reconnect the vehicle to correct the error.</p>
	<p>After checking that there is no more risk, release the emergency stop button located on the front door.</p>
	<p>Open door detected. Door needs to be closed before starting a new charging session</p>

5.3 Emergency stop button

The emergency stop button is located on the bottom left side of the Green Motion DC 22 EV charger, as per Figure 6. Push the button in cases of emergencies.

Figure 6. Location of the emergency stop button

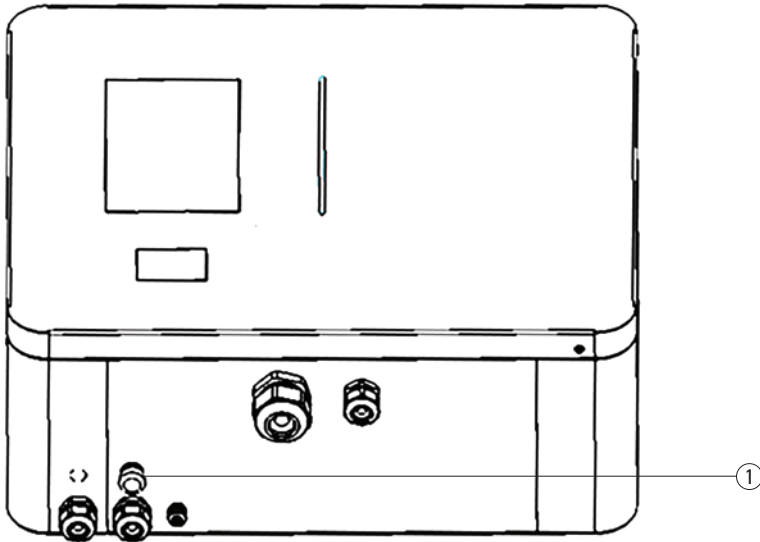

Tag	Description
①	Emergency stop button

6. Software suite

Green Motion DC 22 EV charger works in combination with an advanced software called Charging network manager. This is an all-in-one software management system designed to control the charging stations network. Refer to the Eaton Charging network manager user manual, available on www.eaton.com, for further details.

7. Maintenance



Installation, commissioning, maintenance or retrofitting of the EV charger must be performed by professional and qualified personnel who are responsible for complying with existing standards and local installation regulations.



Before starting connection operations, make sure that the external AC-line main switch is disconnected, and circuit breakers are open.



Any operation requiring the opening of the housing of the EV charger can lead to electric shock hazards.

In case the unit shows a failure and the emergency stop button is pushed, check the integrity of the unit, cables and connectors before starting the maintenance process.

The opening of the EV charger as well as any configuration changes must be carried out by a professional and qualified personnel in accordance with the local safety and electrical regulations and laws.



Before carrying out any maintenance on the unit, disconnect the unit from the power supply and wait at least ten minutes to allow its components to cool down and any static electricity storage devices to discharge.

The enclosure could overheat during its operation or be heated by direct sunlight, and it can cause burns by contact. To avoid burns, please use suitable PPE or wait for the equipment to cool down before accessing it.

7.1 How to put the unit as out of order

The unit can be set as out of order in two ways:

1. On-site method: Press the emergency stop button.
2. Remote method: Access the Eaton Charging network manager and set the unit as out of order.

7.2 Station updates



It is mandatory to install and maintain the units with the latest system updates to enable new features and bug fixes, or the guarantee conditions may be voided.

For units that are online, this must be done via the Eaton Charging network manager software platform. Please refer to the Eaton Charging network manager user manual, available on www.eaton.com, for further details. For units that are offline, please contact your Eaton service representative using the email address BGTechSupport@eaton.com.

7.3 Cleaning or replacing filters



Check the filters on a yearly basis to ensure that they are not obstructed, and they work properly.

In case of obstruction, filters need to be replaced as soon as possible and Eaton recommends not to use the unit and wait for the replacement of the filters.

Before starting any operation, please contact your Eaton service representative using the email address BGTechSupport@eaton.com.

7.4 Disposal

When the charging station reaches the end of its service life, the end user should contact professional and qualified personnel for disposal instructions. Please refer to www.eaton.com/recycling for further details.



The EU Directive on Waste Electrical and Electronic Equipment (WEEE) (Directive 2012/19/EU) establishes common rules on the management of electrical and electronic equipment and minimize its impact — from design until disposal — on the environment. As a manufacturer of electrical and electronic equipment, Eaton actively supports the requirements of the WEEE Directive.

In compliance with the EU standard EN 50419 for marking of electrical and electronic equipment, we include the crossed-out wheeled bin symbol on our products. This symbol alerts users that these products should be recycled in accordance with local environmental regulations and not discarded with household waste. When end users recycle WEEE they are helping to ensure that they are neither incinerated nor sent to landfills, minimizing potential negative impact on human health and the environment.

Any device that is no longer needed must therefore be returned to the distributor or disposed to an authorized collection and recycling center in the area. Eaton encourages all its customers and end users to make responsible decisions when it comes to disposing products.

Eaton is not responsible for the transportation of the device to the collection point or recycling center.

8. Frequently asked questions



This section contains information and procedures for solving possible problems that may occur with the EV charger.

Table 4. Frequently asked questions

Possible problems	Solutions
The EV charger does not start	<ul style="list-style-type: none"> • Check that the connection between the connector of the charging cable and the car socket is properly established. • Check the LED status color and read the indication on the touchscreen display.
The EV charger visual indicators are red	<ul style="list-style-type: none"> • Unplug the connector from the vehicle and reinsert it. Check the LED status color and read the indication on the touchscreen display.
The vehicle does not charge	<ul style="list-style-type: none"> • Visually inspect the condition of either the CCS or CHAdeMo cable. • In case the CHAdeMO cable is used, select the appropriate plug on the touch screen to initiate the charging session.
The charging cable cannot be released from the vehicle	<ul style="list-style-type: none"> • Check that the charging session has been stopped. • Check the LED status color and read the indication on the touchscreen display. • Usually, the connector must be released from inside your vehicle first. Refer to the instruction manual of your vehicle. • In case of an emergency, the cable can always be unlocked using the emergency stop button.
Authentication refused	<ul style="list-style-type: none"> • Check the LED status color and read the indication on the touchscreen display. • Check that the connection of the EV charger to the backend is available.
How long is the warranty period?	<ul style="list-style-type: none"> • The warranty period is 2 years.

If the problem persists, contact your local installer or your Eaton technical support representative using the email address BGTechSupport@eaton.com.

9. Technical data

9.1 Rating plate



To locate the rating plate on the equipment, refer to Figure 7.



The technical specifications shown in this manual do not replace those that appear on the rating plate attached to the equipment.



The labels attached on the equipment must NEVER be removed, damaged, soiled or hidden for any reason.

The information reported on the rating plate:

1. Manufacturer
2. Model
3. Ratings
4. Certification marks
5. Warnings
6. Serial Number



The labels must NOT be hidden with foreign objects (rags, boxes, equipment etc.); they must be periodically cleaned and kept always clearly visible.

Figure 7. Location of the rating plate

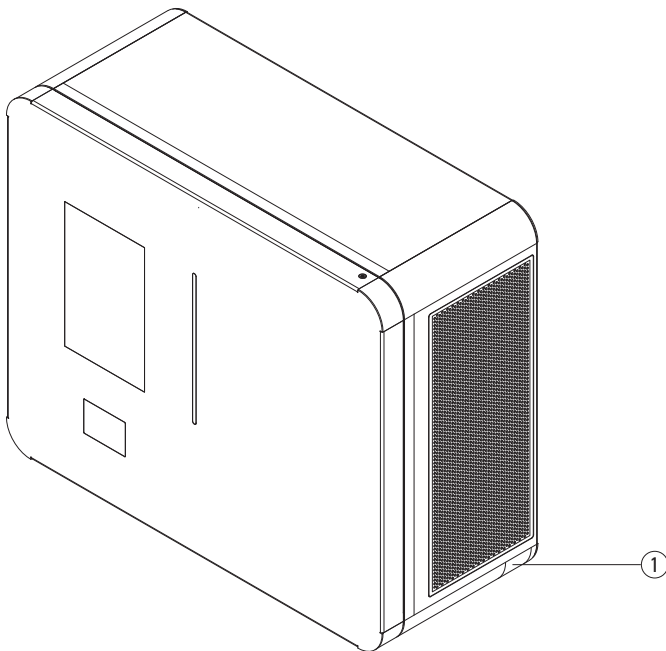

Tag	Description
①	Rating plate

9.2 Technical datasheet

The latest version of the technical datasheet is available for download from www.eaton.com/GreenMotiondc22.

CE certification is also available on www.eaton.com/GreenMotiondc22 or contact your local Eaton service representative.

10. Contact support information

Should any technical problems arise during the operation of the EV charger, contact your Eaton technical support representative for assistance using the email address BGTechSupport@eaton.com.

The following information should be provided when contacting the Eaton technical support representative:

- Product model and serial number,
- Fault messages.

To report concerns or problems regarding the charge point's security, visit this link:

<https://www.eaton.com/us/en-us/company/news-insights/cybersecurity/vulnerabilitydisclosure.html>