

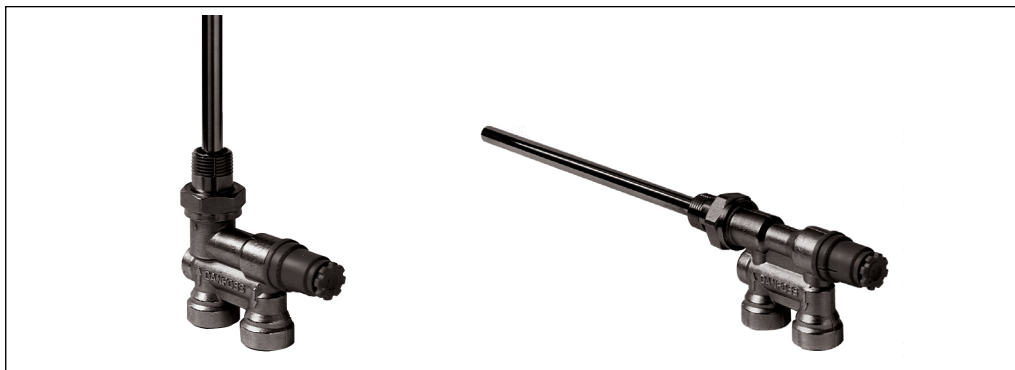

Application



The RA 15/6T valve body fits the RA 2000 thermostats and the ABNR thermal actuators.

The RA 15/6T is a special lance (bypass) valve body which allows the radiator to be connected at one point only, at the side of the radiator or underneath it as required.

RA 15/6T is designed for conventional one-pipe systems with pumped circulation.

The valve body has fixed kv-values.

In the one-pipe system, the constant water flow which is circulated is conveyed partly through the radiator and partly through the bypass built into the valve.

Efficient mounting is enabled by a range of compression fittings for steel, copper, PEX and AluPEX pipes.

To prevent scale and corrosion, the composition of the heating water should comply with VDI (Verein Deutscher Ingenieure) [German Engineering Association] guideline 2035.

Depending on the type of radiator, baffle plates or special connectors which match the radiator may be required in some circumstances. Please note that when a bypass valve is fitted, not all the radiators will provide the performance quoted in their catalogue, and variations in performance may arise where different radiators are combined. In this case, please ask your radiator manufacturer for detailed information.

System



Technical data and code no's

Product	Code no.	Connection ISO 7-1/228-1		$k_{vs}^{1)}$	Max. Pressure (bar)			Max. medium-temperature °C
		System	Radiator		Working <sup>2)</sup>	Differential	Test	
RA 15/6T for floor connection	013G3220	R <sub>p</sub> 1/2 internal	R 1/2	2,15	10	0,6	16	120
	013G3218	G 3/4 external						
RA 15/6T for side connection	013G3270	R <sub>p</sub> 1/2 internal		2,00				
	013G3268	G 3/4 external						

<sup>1)</sup>  $k_{vs} = k_v \text{ bypass} + k_v \text{ radiator}$ . Max. flow through radiator, approx. 30%. <sup>2)</sup> Working pressure = Static pressure + differential pressure

Spare parts

Product	Units per pack	Code no.
Gland seal	10 Pcs.	013G0290

The gland seal can be replaced quickly without draining down the system.

**Dimensioning of one pipe systems**

RA 15/6T is designed for circuits to max. 9 KW (8.000 kcal/h) at  $\Delta t = 20$  K. With a P-band of 2 K ( $^{\circ}\text{C}$ ) flow through the radiator amounts to approximately 30%.

Excess pressure in a riser may be reduced using Danfoss differential pressure controls.

Please pay attention to the fact that not all brands of radiators performs as stated in their documentation when used in one pipe systems with bypass valves.

The radiator manufacturer will inform about possible reduction in performance.

**Construction**

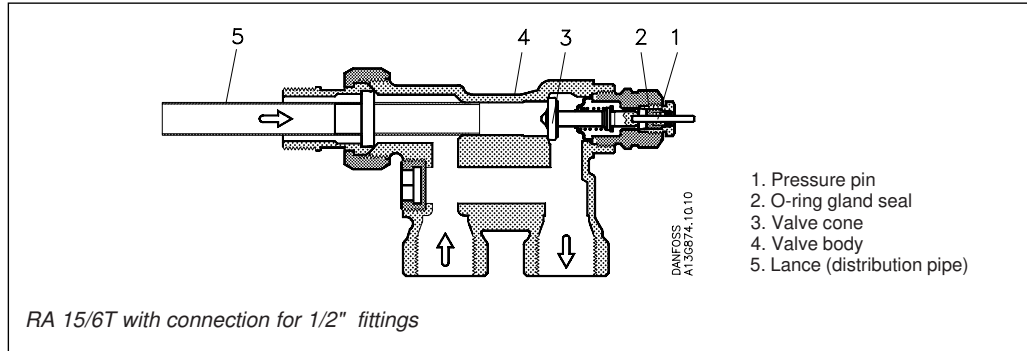

Valve bodies are nickel plated.

*Material in contact with water*

Pipe supporting bush	PP
O-ring	EPDM
Valve cone	NBR
Pressure pin	Chrome steel
Lock washer	Tin alloy
Valve body and other metal parts	Ms 58 brass

**Mounting**

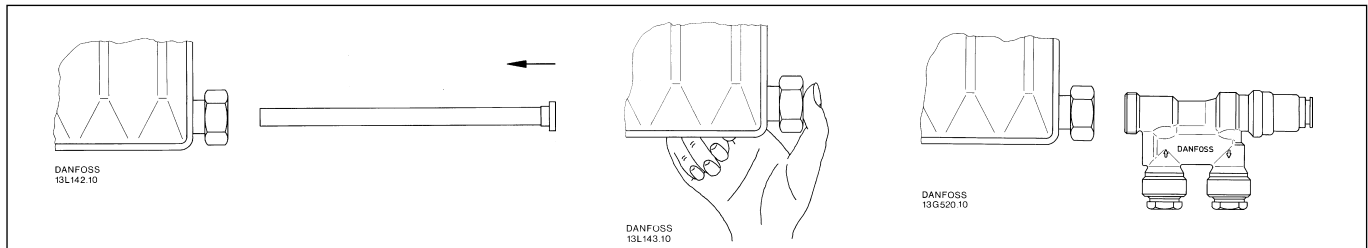

**Dimensions**

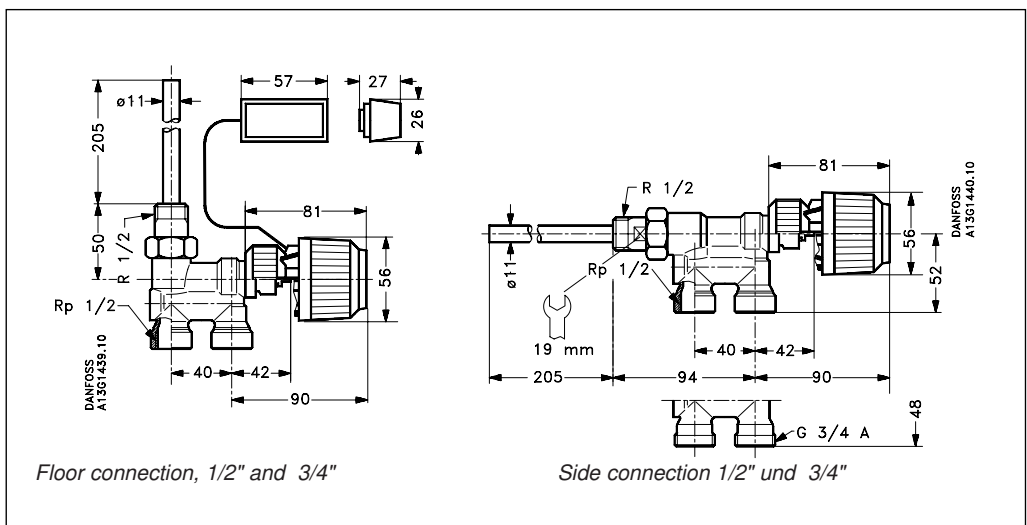

Valve type	Connection	H <sub>1</sub>	H <sub>2</sub>	H <sub>3</sub>	H <sub>4</sub>	a	b
RA 15/6T	R 1/2 internal thread	16	32	205		R 1/2	
RA 15/6T	G 3/4 external thread	20	27	205	21		G 3/4