

Data sheet

RA-C valves for cooling and heating circuits

Description



Together with Danfoss selfacting and electronic controls, RA-C valves make up a perfect combination for control of cooling and heating circuits.

The RA-C valve is a normally open valve. In an application with self-acting sensors type FEK or FED it is ensured that the cooling valve opens when the room temperature is rising above the set temperature.

The RA-C valve has 4 presettings, thus the correct quantity of water is ensured for each cooling circuit and it is PN16 approved.

The valve has two external threads thus fittings for various pipe types may be mounted.

Moreover, Danfoss can also offer a comprehensive range of fittings (see back page).

Shut-off (for isolation during system maintenance) using manual shut off knob

Ordering and Specification

Valve	Connections	Presettings: kv-value ¹⁾ , m ³ /h				k _{v5}	Max. working pressure ³⁾	Max. differential pressure ²⁾	Test pressure	Water temperature	Code No.
		1	2	3	N						
RA-C 15	2 × G 3/4 A	0.30	0.55	0.75	0.90	1.20	10 bar	0.6 bar	16 bar	10 - 120°C	013G3094
RA-C 20	2 × G 1 A	0.80	1.10	1.70	2.60	3.30					013G3096

¹⁾ The kv-values show the flow (Q) in m³/h at a differential pressure (Δp) of 1 bar through the valve. At presetting N the kv-value is shown at Xp = 3 K. The Xp-value decreases at lower presettings thus the kv-value at presetting 1 is shown at Xp = 1 K.

²⁾ The max. differential pressure specified is the maximum pressure at which the valves give satisfactory regulation. As with any device which imposes a pressure drop on the system, noise may occur under certain flow/pressure conditions. A differential pressure between 0.1 and 0.3 bar across the valves is recommended. The differential pressure can be reduced using Danfoss differential pressure regulators.²⁾

³⁾ Shut-off PN10 approved.

Presetting

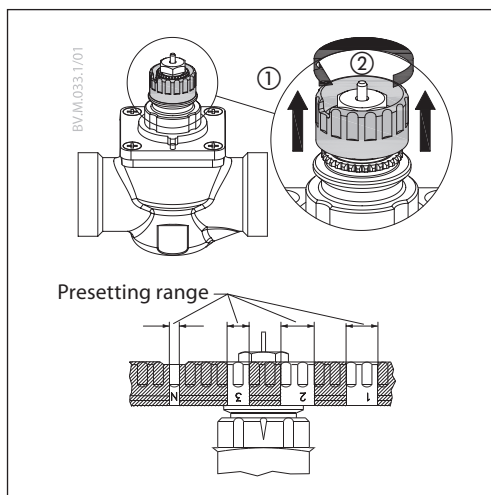

With the valve body type RA-C the calculated setting can be set easily and exactly without using special tools:

- remove the protective cap or sensor element,
- raise the setting ring,
- turn the scale on the setting ring until the required scale value faces the reference mark,
- release the setting ring.

The presetting can be set at the values: 1- 2 - 3 and N. At setting N, the valve is completely open.

A setting in the shaded areas should be avoided. When the sensor element is mounted, the pre-setting is hidden, and is thus protected against alteration.

Pressure and noise conditions

Special demands are made on the various components of the system. This is due to water temperature conditions, the chosen pipe types and pipe dimensions of both chilled ceilings and fancoils/induction units and the structure of the cooling circuits.

In chilled ceilings and fancoils/induction-units relatively large differential pressure and water flow are

often used compared to normal heating systems. This may lead to noise nuisance.

The RA-C valve has especially been designed to correspond to these demands, no matter whether selfacting or electronic controls are used.

Design

1. Gland seal
2. O-ring
3. Pressure pin
4. Seal
5. Regulation spring
6. Presetting bush
7. Valve body
8. K_v -nozzle

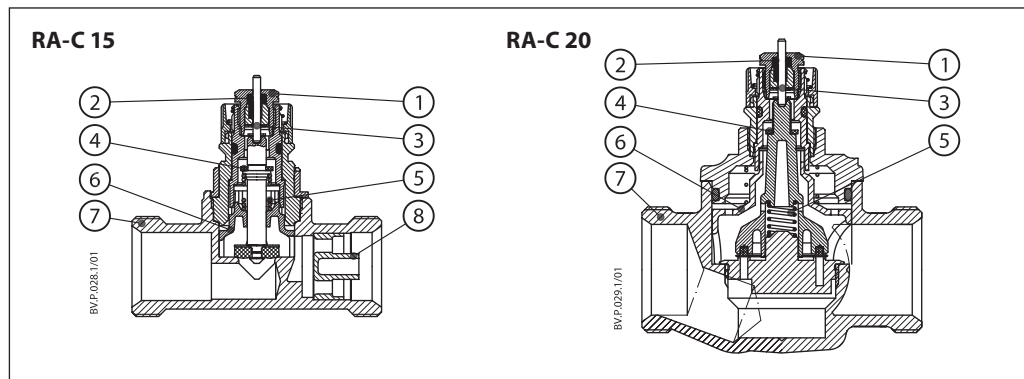

Dimensions

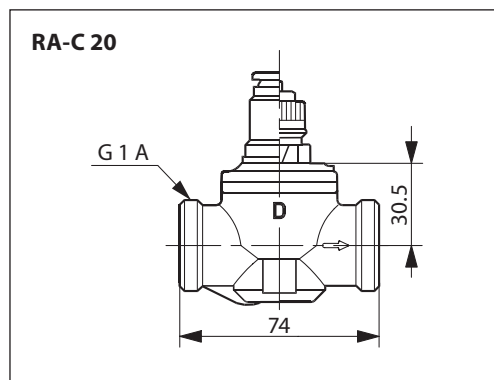
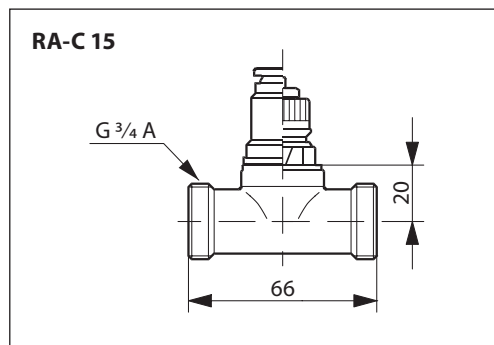

Materials in contact with flow medium ¹⁾

Valve body and other metal parts	Corrosion resistant brass
Spindle	Corrosion resistant brass
Throttle nozzle	PPS
O-rings	EPDM
Valve cone	NBR
Gland seal pressure pin	Chrome steel
k_v -nozzle	PP

¹⁾ **Flow medium:** water and water mixtures with secondary coolants like glycols (regarding suitability and usage especially in not oxygen tight systems please see the instructions given by the coolant producer).

Capacities

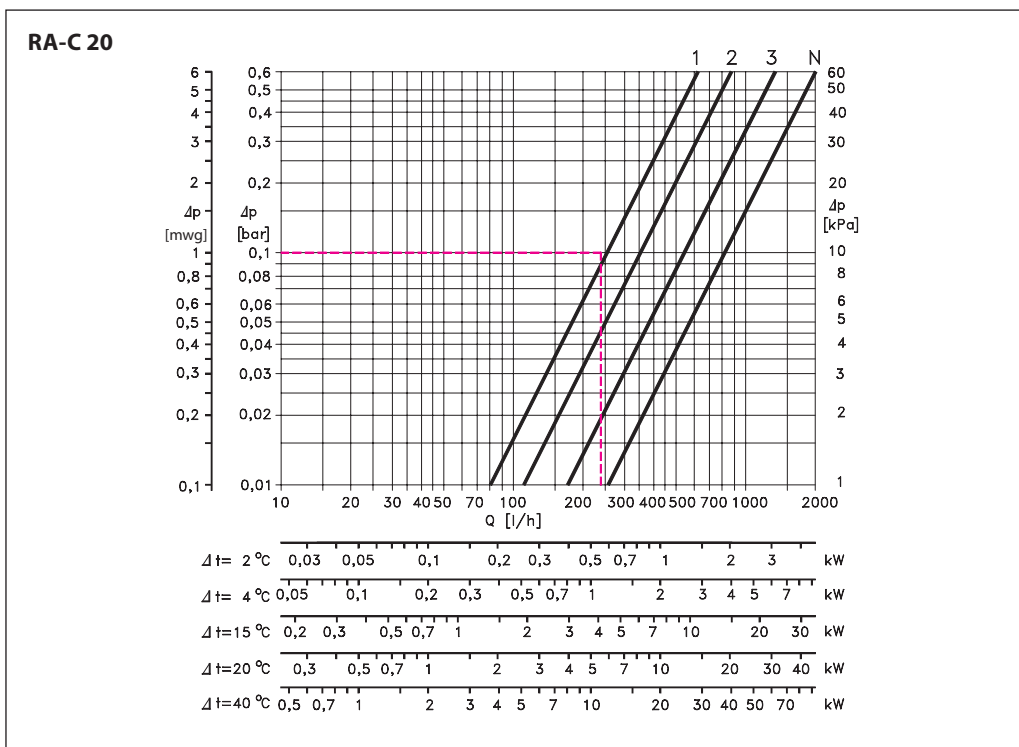
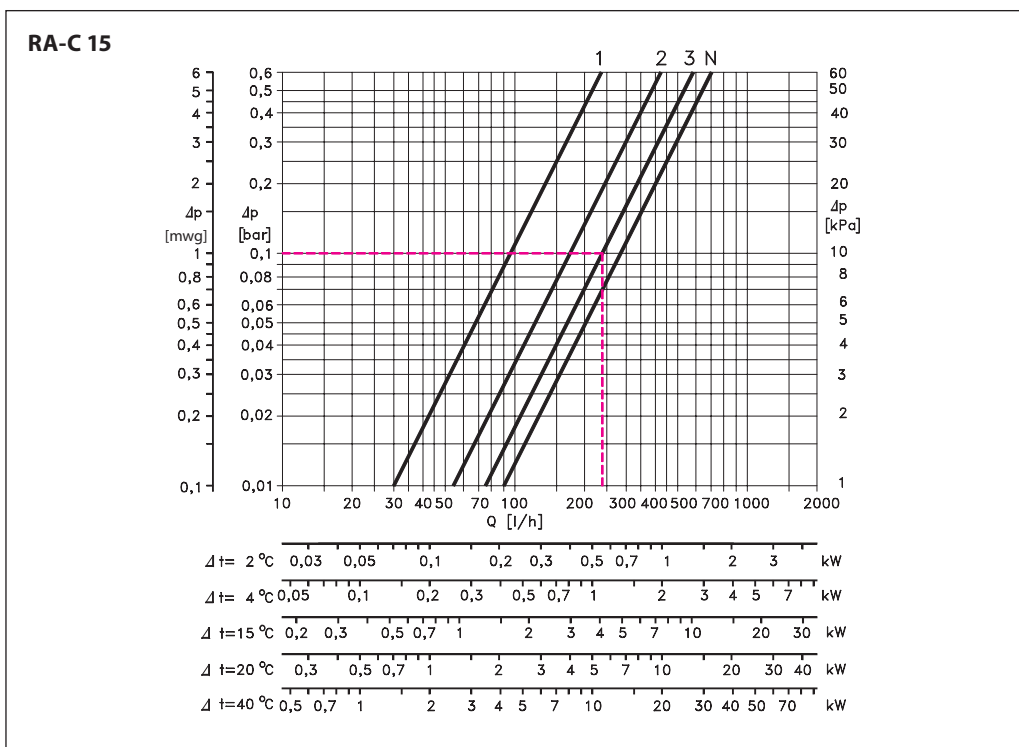

Sizing example, chilled ceiling:

Cooling demand:	$\Phi = 0.55 \text{ kW}$
System temperature rise:	$\Delta t = 2^\circ\text{C}$
Differential pressure:	$\Delta p = 0.1 \text{ bar}$
Calculated water quantity:	$Q = \frac{550}{2 \times 1.16} = 237 \text{ l/h}$

The setting is found in the capacity diagramme: RA-C 15: Presetting value 3
RA-C 20: Presetting value 1

Capacities with P-band between 1 and 3 K

Data sheet

RA-C valves for cooling and heating circuits



Accessories:

Compression fittings for PEX plastic tubing

Compression fittings are for connecting Danfoss valves to circuits in heating systems only. Compression fittings are used for connecting PEX plastic tubings in accordance with DIN 16892/16893.

Maximum operating pressure and temperature are given by the tubing manufacturer. However, 10 bar and 95° C must not be exceeded.



One set consists of one olive, one supporting bush and one union nut. Einbau im Vor- oder Rücklauf

Picture	For PEX plastic tubing Connection	Tube dimension	Max. working pressure	Test pressure	Max. flow	Code No.
 External thread  Internal thread	G 3/4", internal thread	12 x 2 mm	6 bar	10 bar	95 °C	013G4152
		13 x 2 mm	6 bar	10 bar	95 °C	013G4153
		14 x 2 mm	6 bar	10 bar	95 °C	013G4154
		15 x 2.5 mm	6 bar	10 bar	95 °C	013G4155
		16 x 1.5 mm	6 bar	10 bar	95 °C	013G4157
		16 x 2 mm	6 bar	10 bar	95 °C	013G4156
		16 x 2.2 mm	6 bar	10 bar	95 °C	013G4163
		17 x 2 mm	6 bar	10 bar	95 °C	013G4162
		18 x 2 mm	6 bar	10 bar	95 °C	013G4158
		18 x 2.5 mm	6 bar	10 bar	95 °C	013G4159
20 x 2 mm	6 bar	10 bar	95 °C	013G4160		
20 x 2.5 mm	6 bar	10 bar	95 °C	013G4161		

Compression fittings for Alupex tubing

Compression fittings are for connecting Danfoss valves to circuits in heating systems only. When connecting circuits with compression fittings for Alupex tubing, always observe the maximum operating pressure and temperature which are given by the tubing manufacturer. However, 10 bar and 95° C must not be exceeded.







One set consists of one olive, one supporting bush, one insulation washer and one union nut.

Picture	For PEX plastic tubing Connection	Tube dimension	Max. working pressure	Test pressure	Max. flow	Code No.
 External thread  Internal thread	G 3/4", internal thread	12 x 2 mm	6 bar	10 bar	95 °C	013G4182
		14 x 2 mm	6 bar	10 bar	95 °C	013G4184
		15 x 2.5 mm	6 bar	10 bar	95 °C	013G4185
		16 x 2 mm	6 bar	10 bar	95 °C	013G4186
		16 x 2.25 mm	6 bar	10 bar	95 °C	013G4187
		18 x 2 mm	6 bar	10 bar	95 °C	013G4188
		20 x 2 mm	6 bar	10 bar	95 °C	013G4190
		20 x 2.5 mm	6 bar	10 bar	95 °C	013G4191

Compression fittings for steel and copper tubing

Compression fittings are for connecting Danfoss valves to circuits in heating systems only. Compression fittings are used for connecting steel and copper pipes in accordance with DIN 1786/2391.

One set consists of one olive and one union nut. It is recommended to use supporting bushes with soft pipes.

Picture	For PEX plastic tubing Connection	Tube dimension	Max. working pressure	Test pressure	Max. flow	Code No.	
 External thread  Internal thread	G 3/4", internal thread	10 mm	10 bar	16 bar	120 °C	013G4120	
		12 mm	10 bar	16 bar	120 °C	013G4122	
		14 mm	10 bar	16 bar	120 °C	013G4124	
		15 mm	10 bar	16 bar	120 °C	013G4125	
		16 mm	10 bar	16 bar	120 °C	013G4126	
		18 mm	10 bar	16 bar	120 °C	013G4128	
		G 1"	18 mm	10 bar	16 bar	120 °C	013U0134
			22 mm	10 bar	16 bar	120 °C	013U0135
	Manual shut off knob, high pressure					013G3300	
	Manual shut off knob					013G5002	
	Raccords pour joints plats Pour RAC 15					003L0294	
	Raccords pour joints plats Pour RAC 20					003Z4072	

Danfoss can accept no responsibility for possible errors in catalogues, brochures and other printed material. Danfoss reserves the right to alter its products without notice. This also applies to products already on order provided that such alterations can be made without subsequent changes being necessary in specifications already agreed. All trademarks in this material are property of the respective companies. Danfoss and the Danfoss logotype are trademarks of Danfoss A/S. All rights reserved.