

Data sheet

# ChangeOver<sup>6</sup> and NovoCon ChangeOver<sup>6</sup> - Motorized 6-port Ball Valves

Description



The ChangeOver<sup>6</sup> and NovoCon ChangeOver<sup>6</sup> are 6-port motorized ball valves that performs a diverting function between two water circuits in 4-pipe changeover system.

This diverting function allows the cooling and heating capacity of a fan coil unit to be increased for the same compact size compared to a double coil model where the heating and cooling water circuits each have their own coil.

The ChangeOver<sup>6</sup> and NovoCon ChangeOver<sup>6</sup> are 6-port motorized ball valves and not suitable for flow control. Flow is modulated by the AB-QM pressure independent balancing control valve to avoid overflow and reduced efficiency of boiler or chiller.

Typical applications are:

- Radiant ceiling panel, supplied by 4 pipes (Heating supply and return and cooling supply and return)
- Fan coil unit, with single coil supplied by 4 pipes (Heating supply and return and cooling supply and return)

**Features (ChangeOver<sup>6</sup>):**

- No cross-flow between supply circuits
- Single on/off control signal to changeover supply circuits

- Visual indication of actual valve position
- Silent and reliable operation
- Maintenance free
- Teflon seal and polished chrome valve ball to prevent valve sticking
- Manual override

**NovoCon ChangeOver<sup>6</sup>:**

The Actuator NovoCon ChangeOver<sup>6</sup> is a unique 6-port motorised ball valve solution, which is controlled directly from NovoCon<sup>®</sup> S and performs a diverting function between two water circuits in 4-pipe ChangeOver<sup>6</sup> system.

The NovoCon<sup>®</sup> S bus actuator controls the flow and the 6-port diverting valve with actuator, switches between heating and cooling, characterized by that:

- There is only one single plug-in cable, with bus connection and power supply to the NovoCon<sup>®</sup> S actuator. One plug-in cable between the 6-port Actuator NovoCon<sup>®</sup> S ChangeOver<sup>6</sup> and the NovoCon<sup>®</sup> S actuator, which includes a 0-10V control signal, feedback signal and power connection.
- The NovoCon<sup>®</sup> S PIBCV actuator detects by means of comparing 0-10V control & feedback signal if 6-port actuator is in manual operation or if the valve is blocked (feedback signal does not follow control signal).
- 6-port actuator is in maintenance mode able to fully close the valve to prevent any leakage.

**Features (NovoCon ChangeOver<sup>6</sup>):**

- No cross-flow between supply circuits
- Simple connection and control
- Visual indication of actual valve position
- Silent and reliable operation
- Alarm
- Plug-in cable
- Quick-fit to actuator
- Maintenance free
- Teflon seal and polished chrome valve ball to prevent valve sticking
- Manual override

Ordering

| Type  | Cable length (m)                    | Power supply | Connection | Code No. |
|---|-------------------------------------|--------------|------------|----------|
| Actuator ChangeOver <sup>6</sup>                  | 1.5                                 | 24V AC       | Open end   | 003Z3152 |
|   | 5.0                                 | 24V AC       | Open end   | 003Z3153 |
|   | 1.5                                 | 230V AC      | Open end   | 003Z3154 |
| Actuator NovoCon ChangeOver <sup>6</sup>          | 1                                   | 24V AC/DC    | Plug-in    | 003Z8520 |
| Actuator NovoCon ChangeOver <sup>6</sup> Energy   | 1 / Surface temperature sensors 1.5 | 24V AC/DC    | Plug-in    | 003Z8521 |
| Actuator NovoCon ChangeOver <sup>6</sup> Flexible | 1.5                                 | 24V AC/DC    | Open end   | 003Z8522 |

| Type                          | DN | k <sub>vs</sub> (m <sup>3</sup> /h) | Connection | Code No. |
|-------------------------------|----|-------------------------------------|------------|----------|
| ChangeOver <sup>6</sup> valve | 15 | 2.4                                 | Rp ½       | 003Z3150 |
|                               | 20 | 4.0                                 | Rp ¾       | 003Z3151 |

| Type                               | DN | Fire load class <sup>1)</sup> | Code No. |
|------------------------------------|----|-------------------------------|----------|
| ChangeOver <sup>6</sup> insulation | 15 | B2                            | 003Z3159 |

<sup>1)</sup> According to DIN 4102

**Ordering (continued)**
**Accessory**

| Picture | Type                                    | To pipe | To valve | Code No.        |
|---------|---|---------|----------|-----------------|
|         | Union connection (1 pcs.) (CW617N)      | Rp 1/2  | DN 15    | <b>003Z0232</b> |
|         | Union connection (1 PCS.) (CW617N)      | Rp 3/4  | DN 20    | <b>003Z0233</b> |
|         | Long union connection (1 pcs.) (CW617N) | Rp 1/2  | DN 15    | <b>003Z3161</b> |
|         | Long union connection (1 pcs.) (CW617N) | Rp 3/4  | DN 20    | <b>003Z3162</b> |

**Technical data**

| Actuator                          |                 | ChangeOver <sup>6</sup>                              |   | NovoCon ChangeOver <sup>6</sup>   |
|-----------------------------------|-----------------|--|---|---|
| Power supply                      | V               | 24 AC<br>-10%; +15%                                  | 230 AC ± 10%  | 24 AC/DC ± 25%  |
| Operating power consumption       | VA              | Running: 3 VA<br>Standby: 0.5W                       | Running: 4 VA<br>Standby: 2.6W                                | Running: 3.5VA@24V AC / 2.0W@24V DC<br>Standby: 0.5W@24V AC / 0.3W@24V DC   |
| Frequency                         | Hz              | 50/60  |   | 50/60   |
| Running speed                     | sec/90°         | 120  |   | 120   |
| Control input                     |                 | 2-point  |   | Controlled by from NovoCon <sup>®</sup> S CO6, Energy, I/O  |
| Feed back signal                  |                 | /  |   | Unable to move, Cooling, Moving from Cooling towards Heating, Shutt-off, Moving from Heating towards Cooling, Heating |
| Operating torque                  | Nm              | 10   |   | 10  |
| Rotation angle                    |                 | 90°  |   | 90°   |
| Ambient temperature               | °C              | 0 ... 50   |   | 5 ... 50  |
| Storage and transport temperature |                 | -20 ... 70   |   | -20 ... 70  |
| Ambient humidity                  |                 | 95% r.h., non-condensing                             |   | 95% r.h., non-condensing (according to EN 60730-1)  |
| Protection Class                  |                 | III (for 24V version) /<br>II (for the 230V version) |   | III safety extra-low voltage  |
| Grade of enclosure                |                 | IP53 according to EN 60529                           |   | IP53 according to EN 60529  |
| Weight                            | g               | 650  |   | 600   |
| Connection cable                  | m               | 1.5  |   | 1.0   |
|                                   | mm <sup>2</sup> | 3x0.5 (halogen free)                                 |   | 003Z8520: 5x0.32 (halogen free)<br>003Z8521: 5x0.32 (halogen free. Sensors PVC)<br>003Z8522: 4x0.5 (halogen free)     |
|                                   |                 | Applied standards:<br>EN 60730                       | Low Voltage Directive<br>EMC-Directive<br>RoHS II: 2011/65/EU |   |

**Valve**

| DN                           |                   | 15  | 20  |
|------------------------------|-------------------|---|---|
| Diff. pressure <sup>1)</sup> | kPa               | 0.7 (at 200l/h = 100% flow of AB-QM DN15 LF)<br>7.3 (at 650l/h = 100% flow of AB-QM DN15)<br>25 (at 1200l/h = 100% flow of AB-QM DN15HF)  | 7.6 (at 1100l/h = 100% flow of AB-QM DN20)<br>22.6 (at 1900l/h = 100% flow of AB-QM DN20HF) |
| k <sub>vs</sub>              | m <sup>3</sup> /h | 2.4   |   |
| k <sub>vs</sub> of one port  |                   | 3.4   |   |
| Nominal pressure             | PN                | 16  |   |
| Medium temperature           | °C                | 0 ... 90  |   |
| Medium                       |                   | Water and water mixture for closed heating and cooling systems according to plant type I for DIN EN 14868.<br>When used in plant Type II for DIN EN 14868 appropriate protective measures are taken. The requirements of VDI 2035, part 1 + 2 are observed. |   |
| Max. operating torque        | Nm                | 3.0   |   |
| Shut off <sup>2)</sup>       | kPa               | 800   |   |
| Valve neck                   |                   | Quick fix connection  |   |
| Connection                   |                   | Internal thread : Rp 1/2" (ISO 7/1)   | Internal thread : Rp 3/4" (ISO 7/1)   |
| Certifications and standards |                   | PED directive 2014/68/EU Art. 4§  |   |
| Weight                       | g                 | 1140  | 1750  |
| <b>Materials</b>             |                   |   |   |
| Body and connection          |                   | CW 602 N (DZR)  |   |
| Ball                         |                   | CW 614 N Chrome plated  |   |
| Stem                         |                   | CW 614 N Nickel plated  |   |
| Seals                        |                   | P.T.F.E. (TEFLON)   |   |
| O-ring                       |                   | 70 EPDM 281   |   |

<sup>1)</sup> differential pressure for both ports

<sup>2)</sup> manual override (for service purposes only)

Installation positions

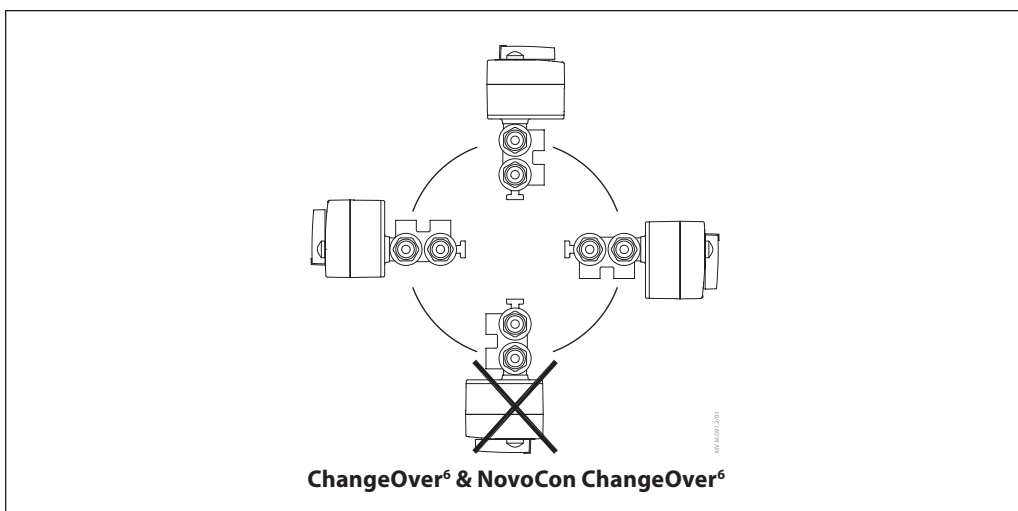

Application principles

ChangeOver<sup>6</sup>

2 connections to the controller.

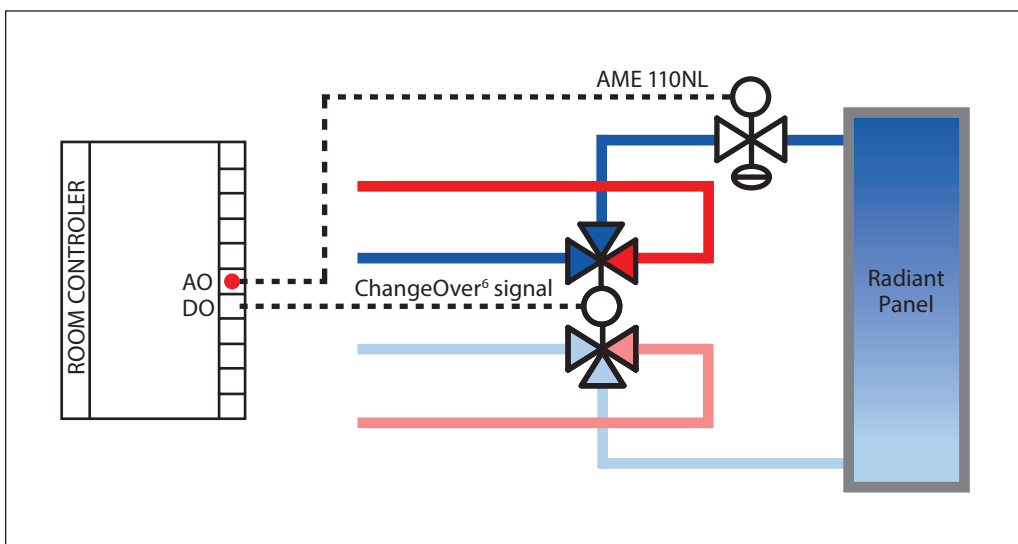

Application principles

NovoCon ChangeOver<sup>6</sup>

Separate maximum flow presetting for cooling and heating is possible in NovoCon<sup>®</sup> S. Feedback signal and alarms are also available.

Only one connection to the controller.

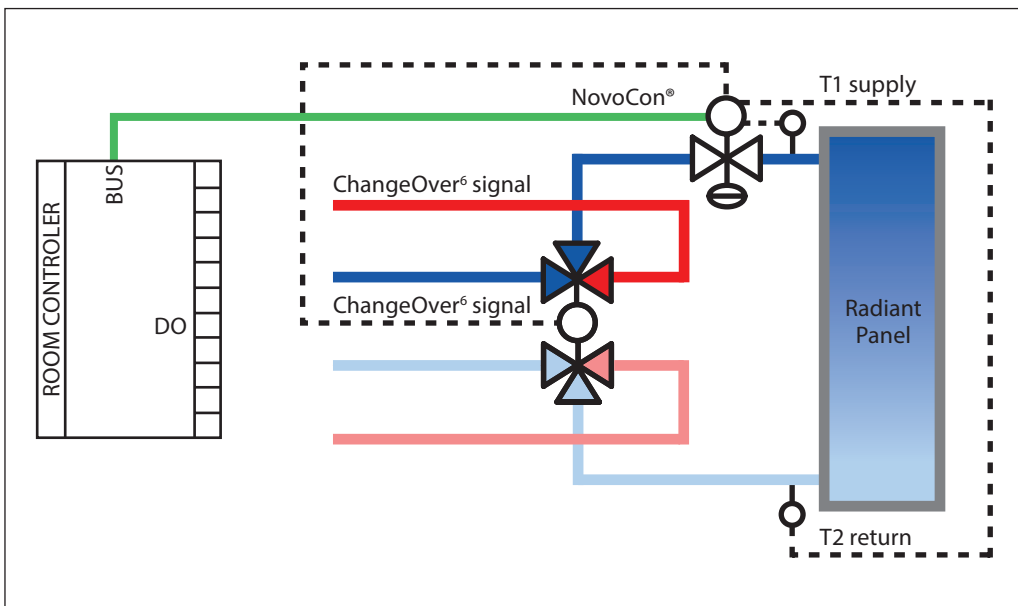

**Application principles  
ChangeOver<sup>6</sup>**

The ChangeOver<sup>6</sup> is a 6-port valve with rotary actuator that switches the flow between heating and cooling. An AB-QM pressure independent balancing and control valve with actuator is used to balance the system and modulate the flow. For modulating control, the AME 110NL actuator should be used. For fieldbus control (BACnet or Modbus) NovoCon<sup>®</sup> S should be used.

**Anti-sticking requirements:**

To reduce the risk of the ball valve sticking due to water quality, the valve must be partially rotated at least every 7 days. An operation at least once per week to reduce the risk of higher torque loading on the actuator. Reversing the control signal for a maximum of 60 seconds will rotate the valve through 45 degrees to the zero flow position without changing between heating and cooling.

**Cooling:**

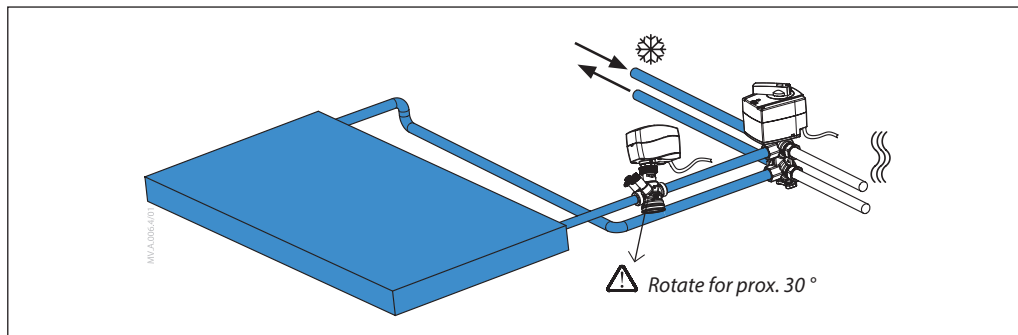

**Heating:**

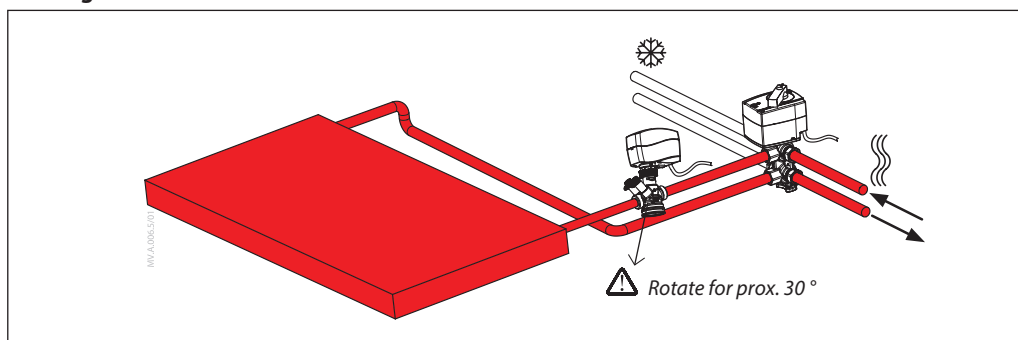

**Application principles  
NovoCon ChangeOver<sup>6</sup>**

The ChangeOver<sup>6</sup> is a 6-port valve with rotary actuator that switches the flow between heating and cooling. An AB-QM pressure independent balancing and control valve with actuator is used to balance the system and modulate the flow. When using the NovoCon<sup>®</sup> S for flow control, both NovoCon<sup>®</sup> S and the Actuator NovoCon<sup>®</sup> ChangeOver<sup>6</sup> are controlled by one single data point.

**Anti-sticking requirements:**

To reduce the risk of the ball valve sticking due to water quality, the valve must be partially rotated at least every 7 days. By default this is handled by NovoCon<sup>®</sup> S.

**Cooling:**

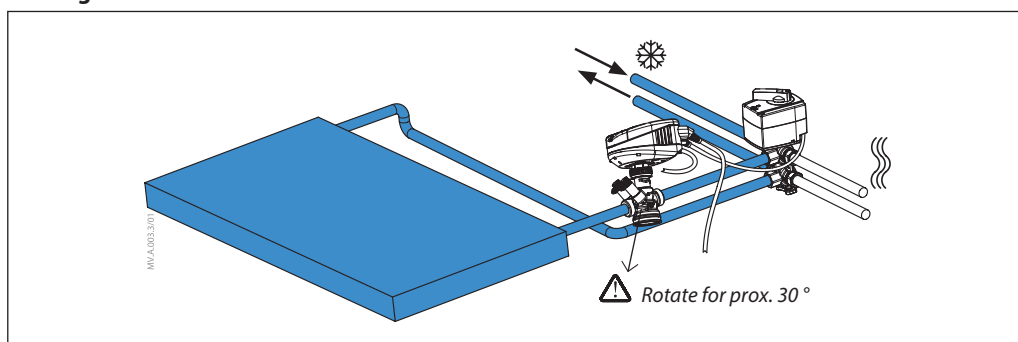

**Heating:**

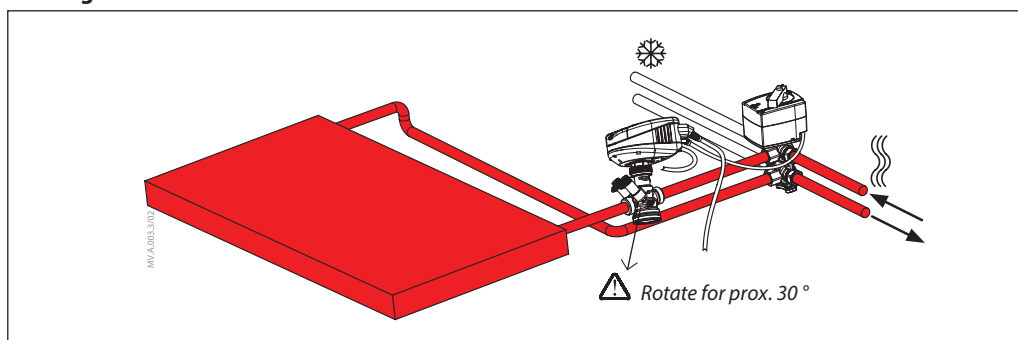

**Marking**

The 6 ports of the ChangeOver<sup>6</sup> valve allow the following flow directions.

|  |  |
|--|--|
|  | <p><b>Control signal - 0 VAC (brown wire):</b><br/>Port 1 to port 2 and port 3 to port 4</p>       |
|  | <p><b>Control signal - 24(230) VAC (brown wire):</b><br/>Port 5 to port 2 and port 3 to port 6</p> |
|  | <p><b>Heating or cooling distribution pipes</b><br/>Ports 1, 4, 5 and 6</p>                        |
|  | <p><b>Terminal unit pipes</b><br/>Ports 2 and 3</p>  |

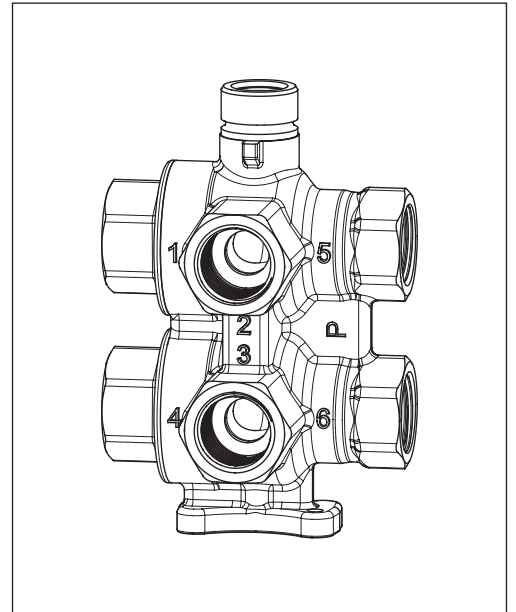

**No mixing**

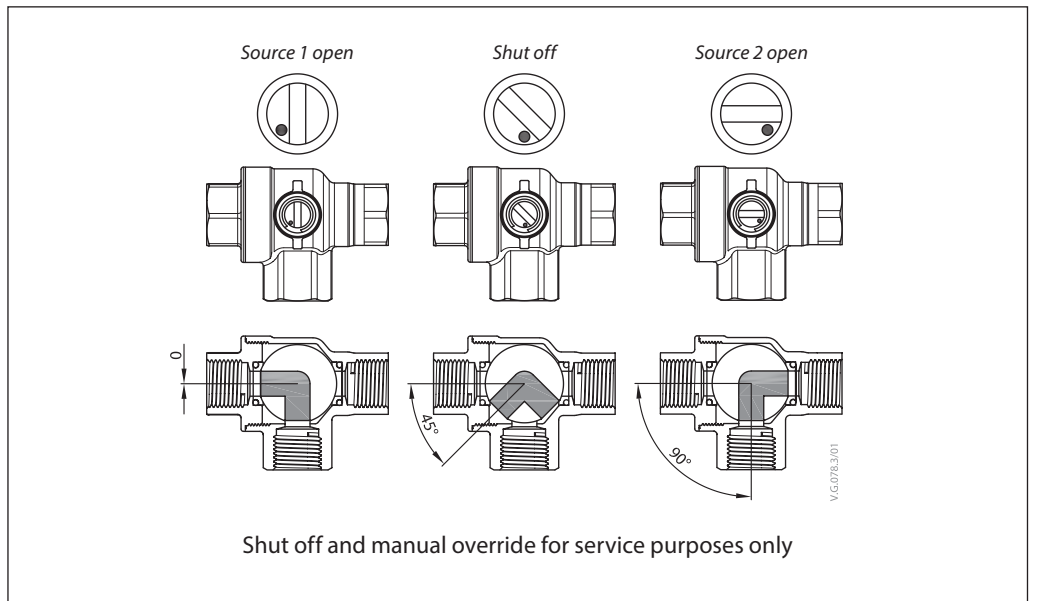

CO6 in contrary to other ball valves includes shut off function. This function can be used only during maintenance and replaces the need of four ball valves.

**Design flow setting for heating and cooling**

(in case of using only one AB-QM as shown on picture above)

**ChangeOver<sup>6</sup>**

The design flow needed for heating is generally less than for cooling. Actuator AME 110NL supports this difference by proportionately limiting the control voltage with a linear characteristic. The NovoCon<sup>®</sup> S enables different design flows to be set via fieldbus communication. See the example below.

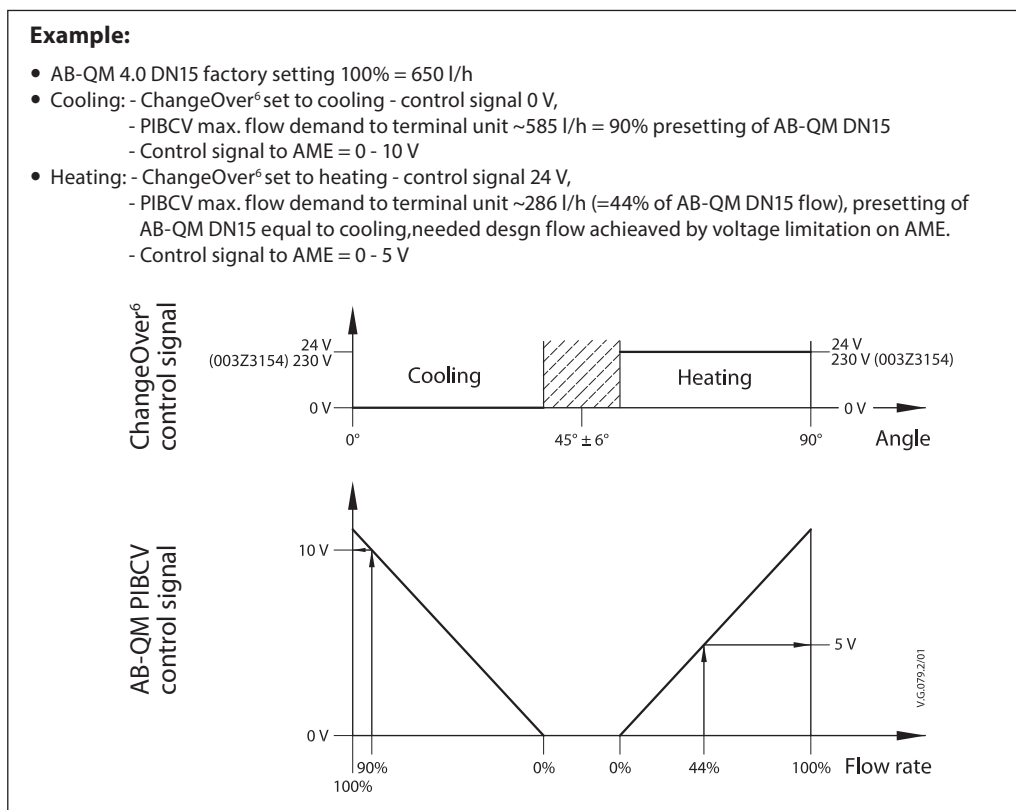

**Control signal**

**NovoCon ChangeOver<sup>6</sup>**

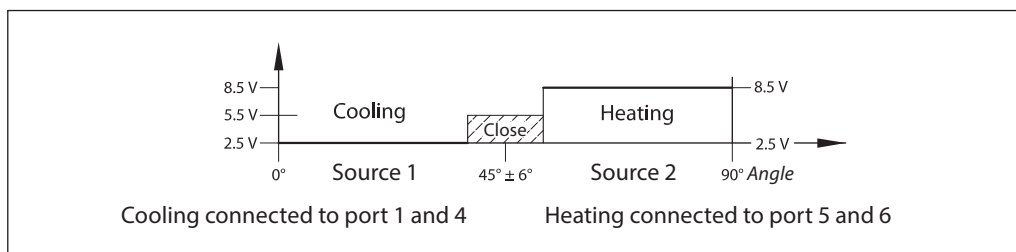

Control signal for the Actuator NovoCon ChangeOver<sup>6</sup>

|          | Stop moving | Cooling | Shut-off | Heating |
|----------|-------------|---------|----------|---------|
| CO6 mode | 1.0 V       | 2.5 V   | 5.5 V    | 8.5 V   |

Feedback signal from the Actuator NovoCon ChangeOver<sup>6</sup>

| Unable to move | Cooling | Moving direction: Cooling to Heating | Shut-off | Moving direction: Heating to Cooling | Heating |
|----------------|---------|--------------------------------------|----------|--------------------------------------|---------|
| 1.0 V          | 2.5 V   | 4.0                                  | 5.5 V    | 7.0 V                                | 8.5 V   |

**Pump head calculation**

- To calculate required pump head:
- determine the critical circuit;
  - calculate pump head without ChangeOver<sup>6</sup> solution (ChangeOver<sup>6</sup> + AB-QM);
  - starting pressure for ChangeOver<sup>6</sup> DN15 solution is ~23.3kPa (ChangeOver<sup>6</sup> 7.3kPa + AB-QM DN15 16kPa);
  - add the starting pressure to the pump head.

LED signalling

| LED signal              | NovoCon ChangeOver <sup>6</sup><br>Description of signal | ChangeOver <sup>6</sup><br>Description of signal  |
|-------------------------|--|---|
| Left/CCW yellow shining | Rotating CCW   | Rotating CCW<br>Full brightness = Turning in progress<br>Half brightness = Reached end position |
| Right/CW yellow shining | Rotating CW  | Rotating CW<br>Full brightness = Turning in progress<br>Half brightness = Reached end position  |
| Green blinking          | Normal operation / invalid signal received               | -   |
| Green shining           | Normal operation   | -   |
| Red blinking            | Valve stuck  | -   |
| Red shining             | Break of line/no signal                                  | -   |

There are combinations of more than one LED possible. In such cases the actual condition is sum of all indications (for example: red blinking, left yellow shining, green shining = rotating CCW, valve stuck)

Wiring

**Actuator ChangeOver<sup>6</sup> (003Z3152 & 003Z3153)**

|        |          |
|--------|----------|
| Common | 1: Blue  |
| 24V AC | 2: Black |
| 24V AC | 3: Brown |

**Actuator ChangeOver<sup>6</sup> (003Z3154)**

|         |          |
|---------|----------|
| Common  | 1: Blue  |
| 230V AC | 2: Black |
| 230V AC | 3: Brown |

**Actuator NovoCon ChangeOver<sup>6</sup>**

- Plug in cable to NovoCon<sup>®</sup> S



Position for heating and cooling can be inverted by changing settings in the NovoCon S actuators.

**Actuator NovoCon ChangeOver<sup>6</sup> Energy**

- Plug in cable including 2xPT1000 surface temperature sensors to NovoCon<sup>®</sup> S

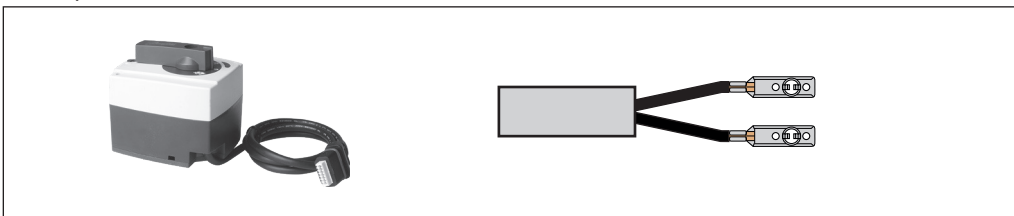

**Actuator NovoCon<sup>®</sup> ChangeOver<sup>6</sup> Flexible**

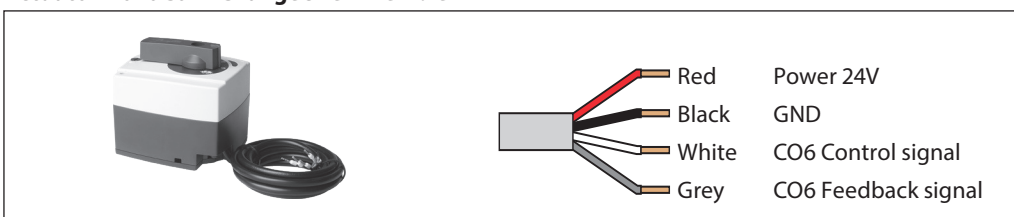

Design

- 1. Valve body
- 2. Connection
- 3. Ball with L-bore
- 4. Ball sealing with O-ring
- 5. Spindle with double O-ring
- 6. Connection spindle with O-ring
- 7. Actuator
- 8. Actuator connection pin
- 9. Snap ring

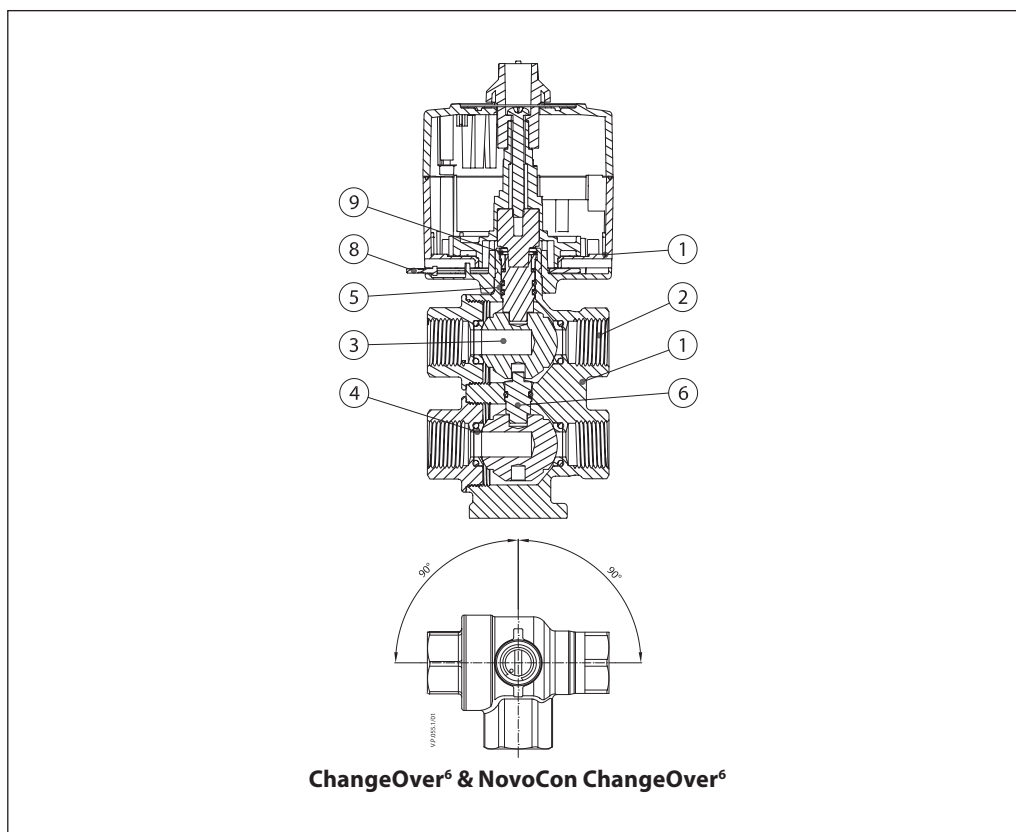

Manual override

(for service purposes only)



**Caution:**  
Do not manually operate the drive if power is connected!

If manual override has been used when power is connected actuator will always return to its end position.

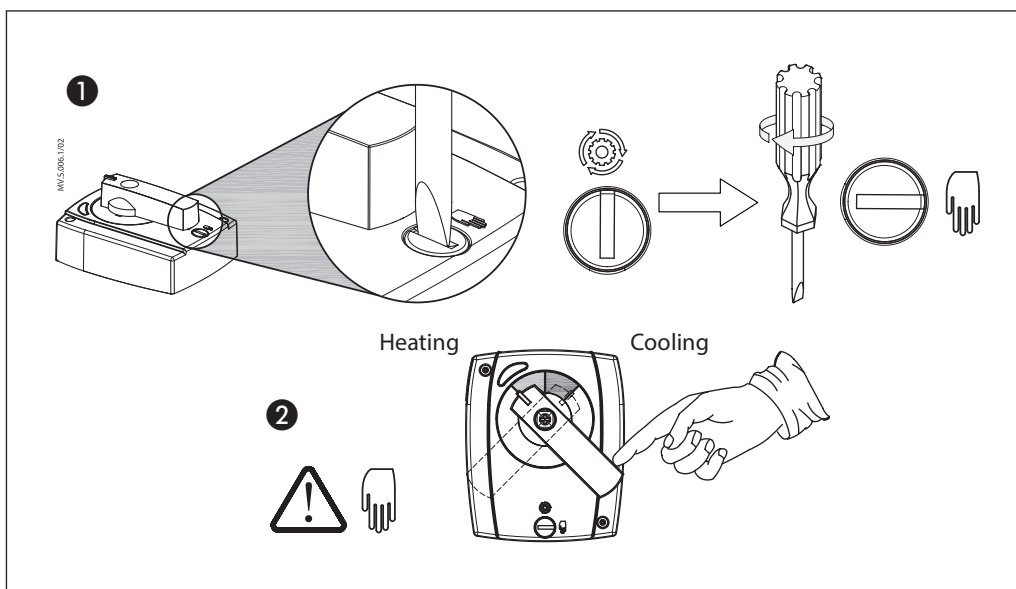

Dimensions

ChangeOver<sup>6</sup> & NovoCon ChangeOver<sup>6</sup>

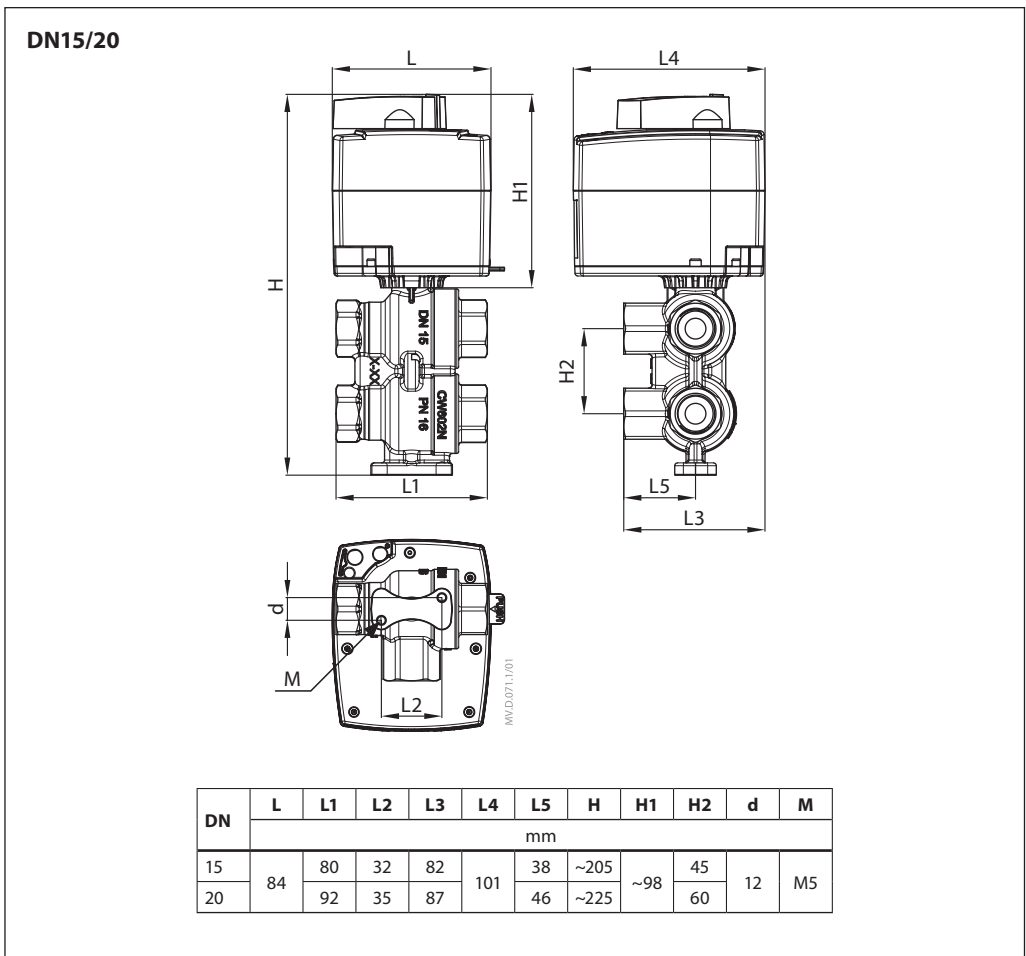

**Tender text:  
ChangeOver<sup>6</sup>**

The Danfoss ChangeOver<sup>6</sup> is a 6-port motorized ball valve that switches flow between a heating and cooling water circuit in a 4-pipe system and eliminates cross-flow. A single digital signal switches between heating and cooling, and flow control must be performed by a separate pressure independent control valve that can modulate flow rates to suit the heating and cooling circuits.

**ChangeOver<sup>6</sup> valve:**

- Differential pressure drop over the ChangeOver<sup>6</sup> valve:
- Differential pressure drop over the valve DN15 is <7.3 kPa for 650l/h, KVS is fixed at 2.4 m<sup>3</sup>/h
- Differential pressure drop over the valve DN20 is <7.6 kPa for 1100l/h, KVS is fixed at 4 m<sup>3</sup>/h
- No cross-flow between the heating and cooling circuits
- Manual shut off up to 8 bar
- Dezincification resistant brass (DZR)
- Medium temperature range 0°C to 90°C

**ChangeOver<sup>6</sup> actuator:**

- Supply Voltage: 24V AC±20% 50-60Hz, or 230V AC±10% 50Hz
- 2 point control input: 24V AC or 230V AC (seperate code)
- Manual override
- Halogen free cable: 1.5m or 5m 24V AC
- Rotation angle: 90 degrees
- Rotating torque: 10 Nm
- IP Class: 53

A separate tender text is available for the Danfoss AB-QM pressure independent balancing & control valve and the AME110NL 0-10V geared actuator and the NovoCon<sup>®</sup> S BACnet and ModBus geared actuator.

---

**Tender text:  
NovoCon ChangeOver<sup>6</sup>**

In a 4-pipe ChangeOver<sup>6</sup> system switching flow between heating and cooling circuits is done with a 6-port motorized ball valve, connected directly to digital PIBCV actuator. Flow control for heating and cooling circuit is performed by a separate pressure independent control valve and modulating actuator. <sup>1)</sup>

**6-port ball valve:**

- Differential pressure drop over the valve DN15 is <7.3 kPa for 650l/h, KVS is fixed at 2.4 m<sup>3</sup>/h
- Differential pressure drop over the valve DN20 is <7.6 kPa for 1100l/h, KVS is fixed at 4 m<sup>3</sup>/h
- No cross-flow between the heating and cooling circuits up to 8 Bar
- Dezincification resistant brass (DZR)
- Medium temperature range 0°C to 90°C
- Zero leakage shut-off function for maintenance

**6-port ball valve actuator:**

- Supply Voltage: 24V AC/DC
- Manual and remote shut off function for maintenance
- Feedback signal for valve position
- LED status indication including alarms for valve blocked or missing signal
- Plug in cable, optional with 2x temperature sensors: 1m or open end 2m cable.
- Power consumption: <4 VA running and 0.5W standby
- Click on mounting

<sup>1)</sup> A separate tender text is available for the Danfoss AB-QM pressure independent balancing & control valve and NovoCon<sup>®</sup> S fieldbus actuator.





**Danfoss A/S**

Climate Solutions • danfoss.com • +45 7488 2222

Any information, including, but not limited to information on selection of product, its application or use, product design, weight, dimensions, capacity or any other technical data in product manuals, catalogues descriptions, advertisements, etc. and whether made available in writing, orally, electronically, online or via download, shall be considered informative, and is only binding if and to the extent, explicit reference is made in a quotation or order confirmation. Danfoss cannot accept any responsibility for possible errors in catalogues, brochures, videos and other material. Danfoss reserves the right to alter its products without notice. This also applies to products ordered but not delivered provided that such alterations can be made without changes to form, fit or function of the product.

All trademarks in this material are property of Danfoss A/S or Danfoss group companies. Danfoss and the Danfoss logo are trademarks of Danfoss A/S. All rights reserved.