

Data Sheet

# Valve bodies type RA-N with integrated presetting and O-ring

Application



Straight version

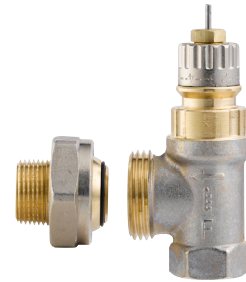

Angle version

All RA-N valve bodies can be used together with all types of thermostatic elements in the RA 2000 series.

The valve bodies are fitted with a  $k_v$  limiting device for pre-setting of max. water flow.

The valve body RA-N is used in two-pipe heating systems and is available with the following setting ranges for max. water flow.

- RA-N 10:  $k_v = 0.08 - 0.43 \text{ m}^3/\text{h}$
- RA-N 15:  $k_v = 0.08 - 0.53 \text{ m}^3/\text{h}$

Each valve body is supplied with a protective cap and adjusting screw which can be used for manual regulation during the construction phase.

The protective cap must not be used as a manual shut off device. A special manual shut off device (code no. 013G5000) should be used.

To be able to distinguish between other valve bodies of the RA 2000 series the protective cap is equipped with a red screw setting.

Compression fittings for 15mm, 10mm or 8mm copper tube are available for valve body RA-N with 3/8" and 1/2" BSP connections.

Valve bodies are manufactured from brass with nickel plating. The pressure pin of the gland seal is of chromium steel and works in a lifetime lubricated O-ring. The complete gland seal assembly can be replaced without draining down the system.

Should water treatment be used it is essential that dosing instructions of the manufacturer are strictly observed. It is recommended that formulations containing mineral oil are avoided.

Quality



Thermostatic sensors RAS-C<sup>2</sup> with RA-N radiator valves are manufactured to the highest standards, and are approved to the European standard EN 215.

All Danfoss radiator thermostats are manufactured in factories, assessed and certified by BSI (British Standards Institution) against ISO 9000 and ISO14001.

Principles

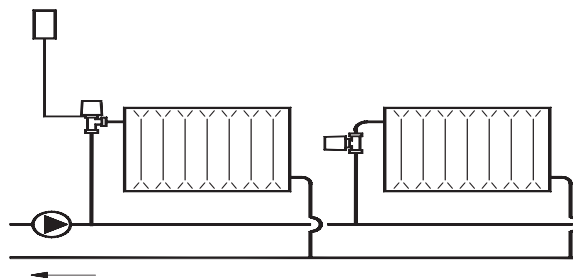

Data and ordering

Type	Design	Connections		Pre-setting					
		Inlet	Outlet	$k_v$ -max. <sup>1)</sup> (m <sup>3</sup> /h at $\Delta p = 1$ bar)					$k_{vs}$
		Rp	R	1	2	3	4	N	N
RA-N 10	Angle	3/8	3/8	0.08	0.18	0.21	0.31	0.43	0.65
	Straight	3/8	3/8	0.08	0.18	0.21	0.31	0.43	0.65
RA-N 15	Angle	1/2	1/2	0.08	0.18	0.25	0.38	0.53	0.90
	Straight	1/2	1/2	0.08	0.18	0.25	0.38	0.53	0.90

Type	Design	Max. work. press.	Max. diff. <sup>2)</sup> press.	Test	Max. work. temp.	Code no
		bar	bar	bar	°C	
RA-N 10	Angle	10	0.6	16	120	<b>013G1011</b>
	Straight	10	0.6	16	120	<b>013G1012</b>
RA-N 15	Angle	10	0.6	16	120	<b>013G1013</b>
	Straight	10	0.6	16	120	<b>013G1014</b>

<sup>1)</sup> The  $k_v$ -value indicates the water flow (Q) in m<sup>3</sup>/h at a pressure drop ( $\Delta p$ ) across the valve of 1 bar;  $k_v = Q : \sqrt{\Delta p}$ . At setting N the  $k_v$ -value is stated according to EN 215, at  $X_p = 2K$  i.e. the valve is closed at 2°C higher room temperature. At lower settings the  $X_p$  value is reduced to 0.5K of the setting value 1. The  $k_{vs}$ -value states the flow Q at a maximum lift, i.e. at fully open valve at setting N.

<sup>2)</sup> Working pressure = static + differential pressure. The maximum differential pressure specified is the maximum pressure at which the valves give satisfactory regulation. As with any device which imposes a pressure drop in the system, noise may occur under certain flow/pressure conditions. To ensure quiet operation, maximum pressure drop should not exceed 30 to 35 kPa. The differential pressure can be reduced by the use of the Danfoss differential pressure regulators types AVD, AVDL, AVDS, IVD or ASV-P.

Accessories

Product	Dimension	For valve body	Code no.
Gland seal	-	All RA valves	<b>013G0290</b>
Compression fitting for steel and copper tubes	Rp 3/8 x Ø10 mm	RA-N 10	<b>013G4100</b>
	Rp 3/8 x Ø12 mm		<b>013G4102</b>
	Rp 1/2 x Ø10 mm	RA-N 15	<b>013G4110</b>
	Rp 1/2 x Ø12 mm		<b>013G4112</b>
	Rp 1/2 x Ø15 mm		<b>013G4115</b>
O-rings service set for tail pieces DN10			<b>013G1019</b>
O-rings service set for tail pieces DN15			<b>013G1020</b>

All accessories comes in boxes of 10 pcs.

Setting

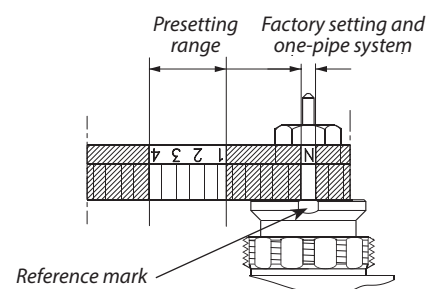
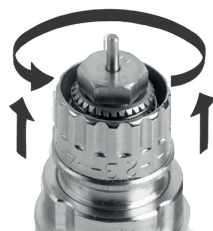

## Operating principle

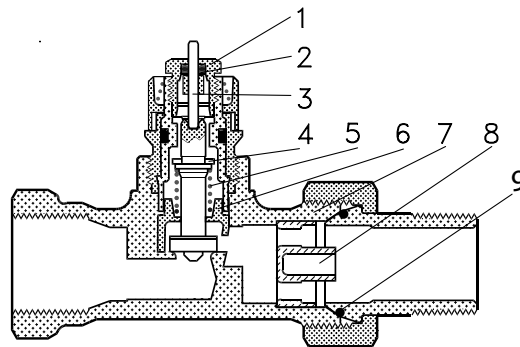

1. Gland seal
2. O-Ring
3. Pressure pin
4. Seal
5. Regulation spring
6. Setting dial
7. Valve body
8.  $k_v$ -nozzle
9. O-ring

The radiator thermostats consist of the thermostatic elements and the valve body RA-N. The element and the valve body are ordered separately.

A The gland seal of the valve can be changed in operation, i.e. with water and pressure on the system.

Valve body and other metal parts	Ms 58, brass
$K_v$ -limiter	PPS
O-ring	EPDM
Valve cone	NBR
Pressure pin and valve spring	Chrome steel
Nozzle	PP

*The valve bodies are nickle-plated on the outside.*

Max. ambient temperature	60 °C
Max. medium temperature	120 °C
Max. working pressure	10 bar
Test pressure	16 bar

Capacities

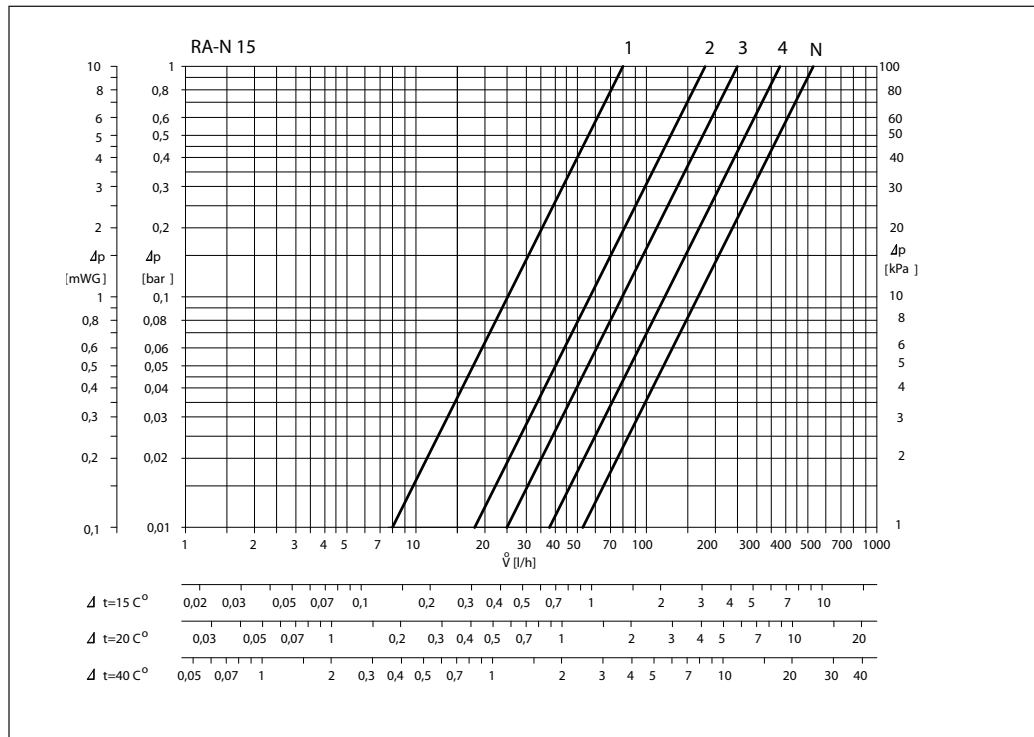
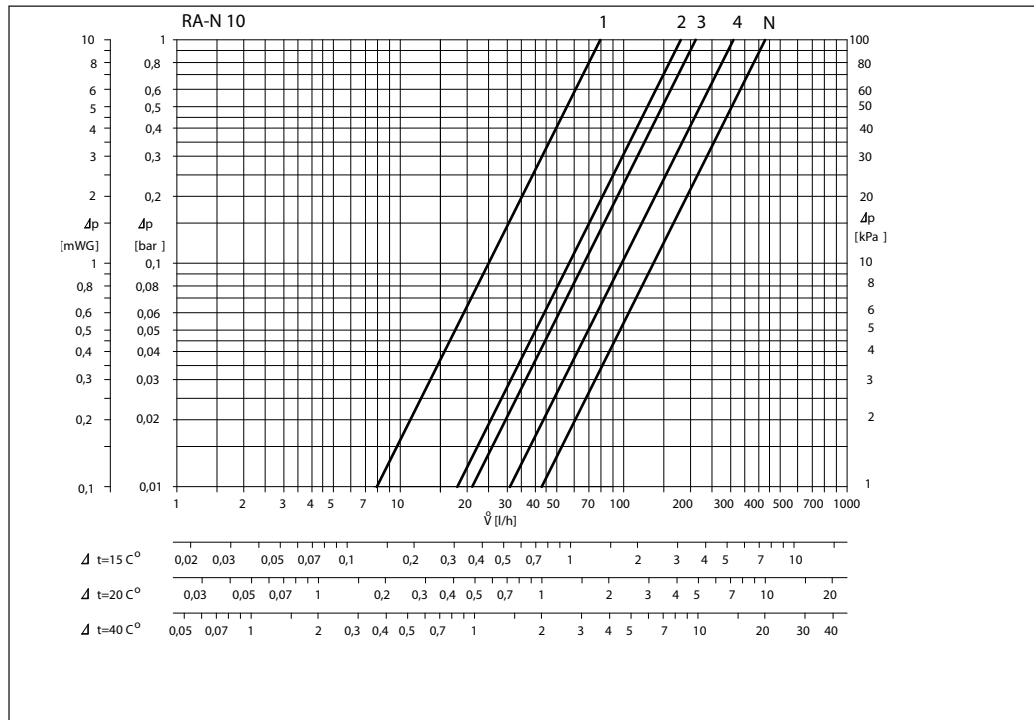

**Sizing example:**

Required heat:	1.6 kW
Cooling across radiator:	20° C
Flow through radiator:	$Q = \frac{1.6}{20 \times 1.16} = 0.07 \text{ m}^3/\text{h}$
Pressure drop across valve:	$\Delta p = 1 \text{ mGW}$
Valve setting:	RA-N 10      4
	RA-N 15      3

Alternatively the setting can be read directly in the table "Data and Ordering".

$$k_v = \frac{Q \text{ (m}^3/\text{h)}}{\sqrt{\Delta p \text{ (bar)}}$$

Dimensions

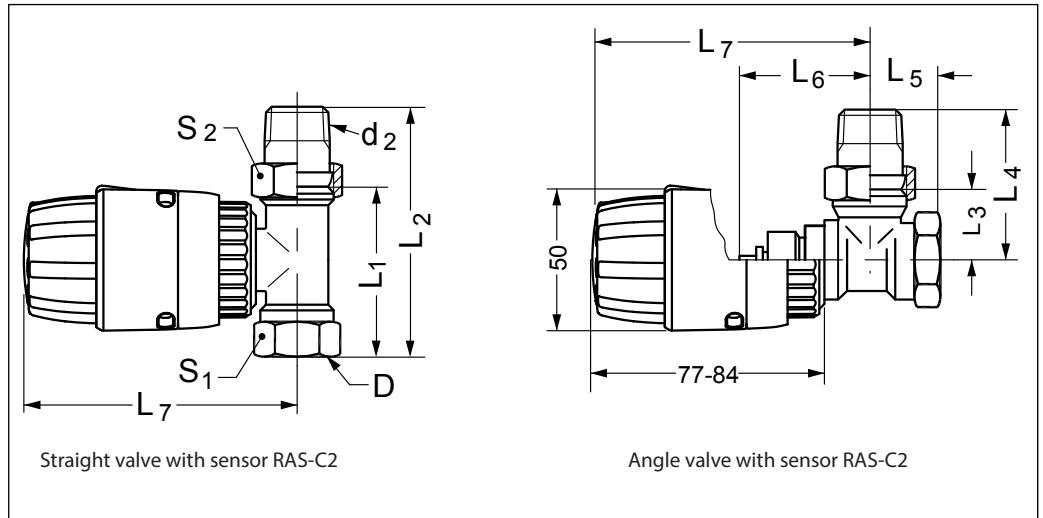

Type	ISO 7-1			L <sub>1</sub>	L <sub>2</sub>	L <sub>3</sub>	L <sub>4</sub>	L <sub>5</sub>	L <sub>6</sub>	L <sub>7</sub>	Arc. flats	
	DN	D	d <sub>2</sub>								S <sub>1</sub>	S <sub>2</sub>
RA-N 10	10	R <sub>p</sub> 3/8	R 3/8	50	75	24	49	20	47	92-99	22	27
RA-N 15	15	R <sub>p</sub> 1/2	R 1/2	50	82	26	53	23	47	92-99	27	30

**Danfoss A/S**

Climate Solutions • danfoss.com • +45 7488 2222

Any information, including, but not limited to information on selection of product, its application or use, product design, weight, dimensions, capacity or any other technical data in product manuals, catalogues descriptions, advertisements, etc. and whether made available in writing, orally, electronically, online or via download, shall be considered informative, and is only binding if and to the extent, explicit reference is made in a quotation or order confirmation. Danfoss cannot accept any responsibility for possible errors in catalogues, brochures, videos and other material. Danfoss reserves the right to alter its products without notice. This also applies to products ordered but not delivered provided that such alterations can be made without changes to form, fit or function of the product. All trademarks in this material are property of Danfoss A/S or Danfoss group companies. Danfoss and the Danfoss logo are trademarks of Danfoss A/S. All rights reserved.