



MCV109A

Electrical Displacement Control-MV

BLN-95-8985-1

Issued: June 1995

DESCRIPTION

The MCV109A Electrical Displacement Control (EDC-MV) is a two-stage electrohydraulic motor stroke control which uses mechanical feedback to establish closed loop control of the swashplate angle of Danfoss Series 2X and Series 3X motors.

The first stage, the MCV116 Pressure Control Pilot, is a torque motor actuated, double nozzle flapper valve that produces a differential output pressure proportional to the applied electrical signal. The second stage uses the differential pressure to drive its double spool arrangement and port oil to the motor servo cylinders.



FEATURES

- Single command source can be used to control both hydrostatic pump and motor
- Servo control deadband independent of signal null deadband: offers safety combined with accurate and responsive control.
- Resistance to the environment: standard silicone oil filled torque motor, environmentally sealed first/second stage interface, full environmental testing.
- Pilot supply screens in series, upstream screen is externally serviceable
- First and second stages can be individually replaced
- Swashplate movement can be visually detected
- Single or dual coil torque motor

ORDERING INFORMATION

MCV109s are ordered for the particular motor on which they are to be mounted. Link Installation Kits, as ordered in the table below, include: orifices, retaining ring, drag link, spacer plate, swashplate pin, link and ball assembly, hex screws, O-rings and gaskets. In some cases not all the above are necessary for installation and they are not included in the kit.

TABLE A. INFORMATION NECESSARY TO SPECIFY THE LINK INSTALLATION KIT.

KK041 **XX**

MOTOR SERIES _____

Order the valve itself through the following table:

TABLE B. INFORMATION NECESSARY TO SPECIFY THE ELECTRICAL DISPLACEMENT CONTROL.

MCV109A59 **XX**

PILOT STYLE _____

The EDC Pilot comes in five styles:

PILOT STYLE	DESCRIPTION
22	Single Coil, Packard Connector
23	Dual Coil, Packard Connector
26	Single Coil, MS Connector
27	Dual Coil, MS Connector

The standard EDC Pilot is a single coil (one input to the torque motor) (see Block Diagram), silicone oil filled, Packard Connector device. The options are a dual coil, which allows two command sources to be combined at the torque motor, the resulting signal being the difference between the two, a MS3102C14S-2P (Danfoss Part Number K01314) connector.

ORDERING INFORMATION *(continued)*

SPARE PARTS

See the Spare Parts diagram for a list of spare parts available for the MCV109A. Other non-standard spare parts, such as orifices, may be available upon request.

Order Danfoss Pressure Override Valve through Danfoss Distributors.

Order the EDC either factory installed on motors or as an individual control.

SPARE PARTS

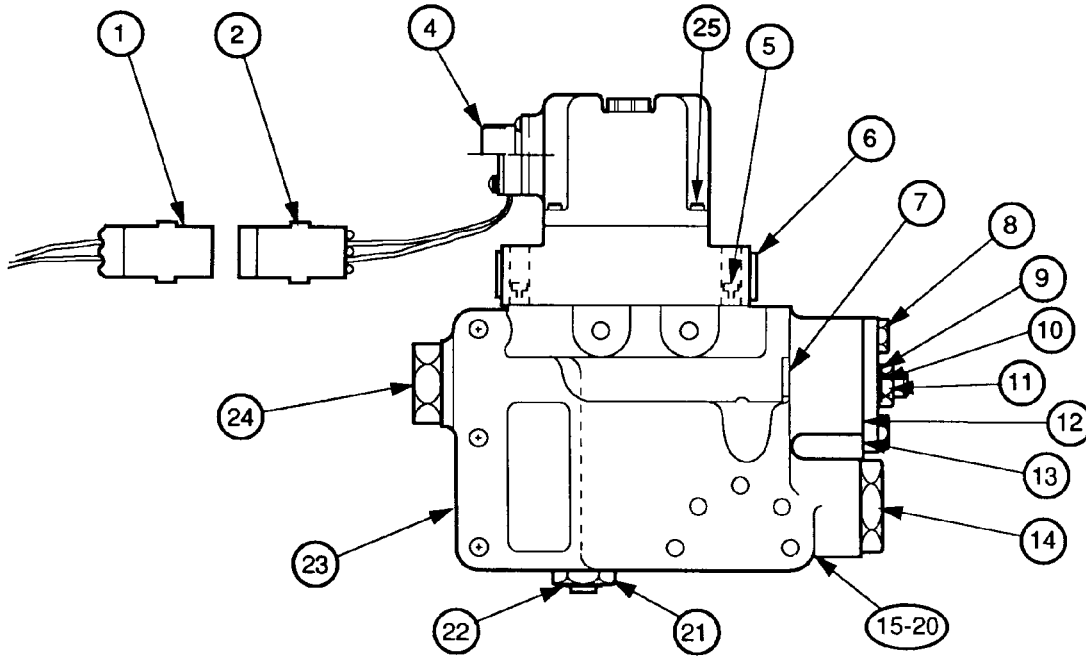

1238E

ITEM NUMBER	PART NUMBER	DESCRIPTION	ITEM NUMBER	PART NUMBER	DESCRIPTION
1	K03383	Mating Connector 2-Pin (Unassembled)	14	K07028	Plug
	K03384	Mating Connector 4-Pin (Unassembled)		K07011	O-Ring For Item 14
2	K03377	Device Connector 2-Pin (Unassembled)	15	K07163	Spacer - Size 20
	K03378	Device Connector 4-Pin (Unassembled)	16	K07164	Spacer - Size 26
3	K01314	Device MS Connector	17	K07128	(3) Port Screens
4	K08106	Mating MS Connector (90°)	18	K07136	(2) .052 Orifices
5	K07055	#10-32 X 5/8 Socket Head Cap Screw	19	K07006	(3) O-Ring For Ports
6	K01291	(2) Plugs	20	K07182	EDC Gasket
7	K07612	Filter Assembly	21	K07160	Linkage Bushing
8	K07034	(2) Screws, Null Adjust Cover		K07009	O-Ring, Linkage Bushing (1 Each)
9	K08387	Seal Washer	22	K02611	Snap Ring
10	K10911	Seal Washer Retainer	23	K04448	Plug
11	K07000	#3/8-32 Nut Null Adjust	24	K07159	Plug
12	K08133	Gasket Null Adjust Cover		K07010	O-Ring For Item 15
13	K07158	Null Adjust Cover	25	K07005	O-Ring Linkage Shaft
			26	CAUTION	<i>Do Not Remove (4) Cover Screws</i>

TECHNICAL DATA

ELECTRICAL

THRESHOLD/RATED OUTPUT CURRENT

The current required to come off stroke (threshold) and to reach full 6° destroke (rated output) will be per the following table.

FINAL TWO DIGITS OF EDC PART #	THRESHOLD SETTING	RATED OUTPUT CURRENT
22 or 26	85 mA	140 mA (±10%)
23 or 27	125 mA	185 mA (±10%)

See Performance Curve and Wiring Schemes diagrams.

The device is capable of operating continuously at 125% of rated current at 104° C (220° F) oil temperatures.

COIL IMPEDANCE

23 ohms (single coil)
 19 ohms (A, B terminals) and
 15.5 ohms (C, D terminals) (dual coil)

HYSTERESIS

4 mA (.85 degrees swashplate angle) maximum at .01 Hz

LINEARITY

10% maximum of swashplate change between any two points

PHASING

A positive voltage applied to Terminal B (Red lead) will cause a pressure rise at the C2 port

SENSITIVITY

The valve shall respond to a 2% change in input current throughout the rated current range

HYDRAULIC

FLUID

Automatic transmission fluid or hydraulic oil, such as Mobil DTE 24 or equivalent

FILTRATION

The system hydraulics shall have 10 micron or better filtration

CASE PROOF PRESSURE

500 psi at 121° C (250° F)

CASE PRESSURE WITH NO EXTERNAL LEAKAGE

200 psi, minimum

RATED CASE OPERATING PRESSURE

40 psi

RATED FLOW

1.15 minimum to 1.45 maximum gpm (standard device)
 1.50 minimum gpm (high response)
 with cylinder ports connected and 200 psi supply pressure

HYSTERESIS

4 mA maximum at .01 Hz

OPERATING SUPPLY PRESSURE

215 psi above case pressure

MAXIMUM NULL LEAKAGE

.65 gpm (standard)
 1.25 gpm (high response)
 at 200 psi across the valve with oil of 145-160 SUS at 38° C (100° F)

WARNING

When using a pulse width modulated valve driver, do not use a carrier frequency between 200 and 600 Hz. If these frequencies cannot be avoided, consult the factory. Do not use a pulse current of more than 120% of that required for full output. Failure to meet the above conditions can cause severe damage to the valve which will result in improper system operation.

CONNECTION DIAGRAM

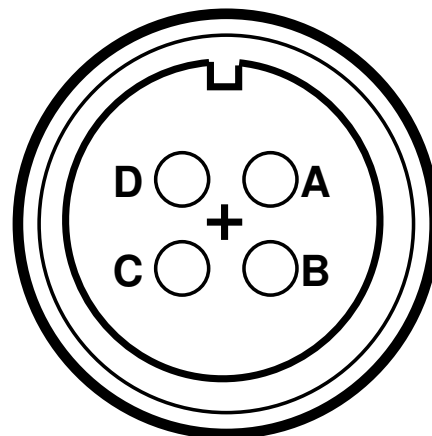

1276

Pin Orientation of the Optional MS Connector, Part Number (K01314) MS3102C14S-2P.

WIRING DIAGRAM (Typical)

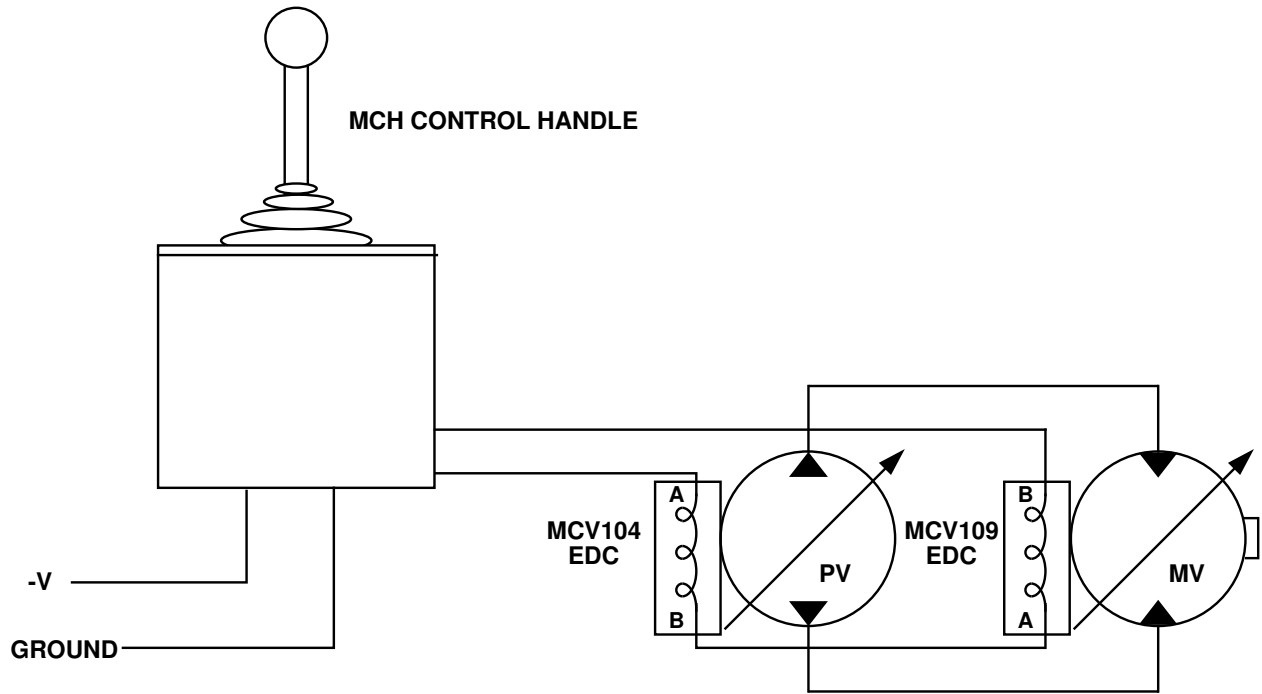

1444

PERFORMANCE CURVE

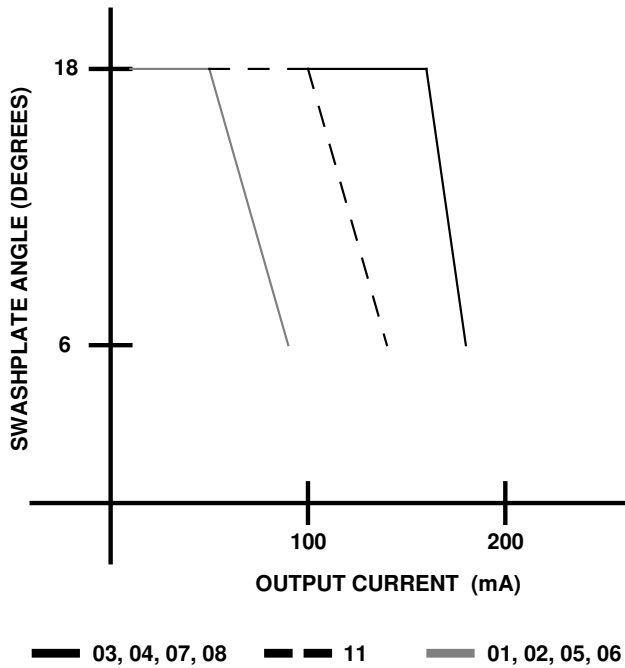

1446A

Current vs. Swashplate Angle for the MCV109. Legend References the Last Two Digits of the Part Number.

WIRING SCHEMES

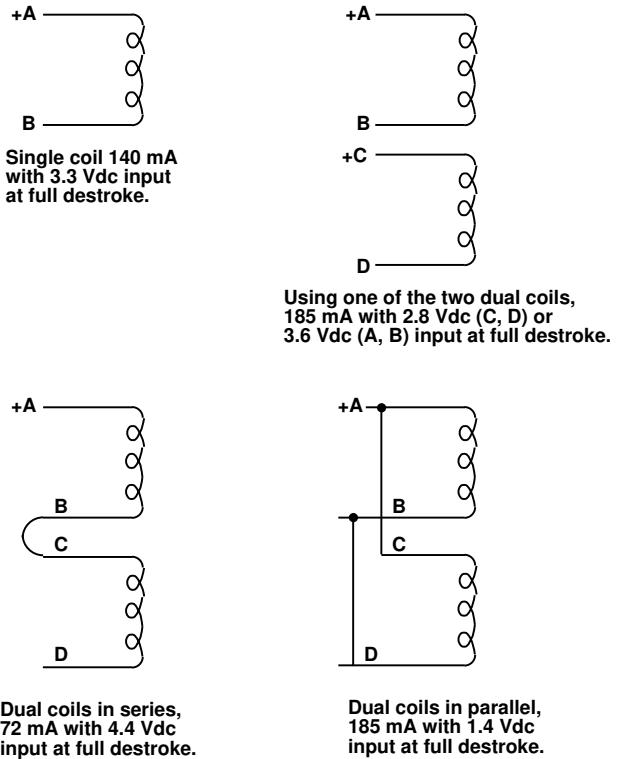

1447

Wiring Schemes Using Four Different Pilot Valve Configurations for the EDC. Input Voltages Specified at 24° C.

DIMENSIONS

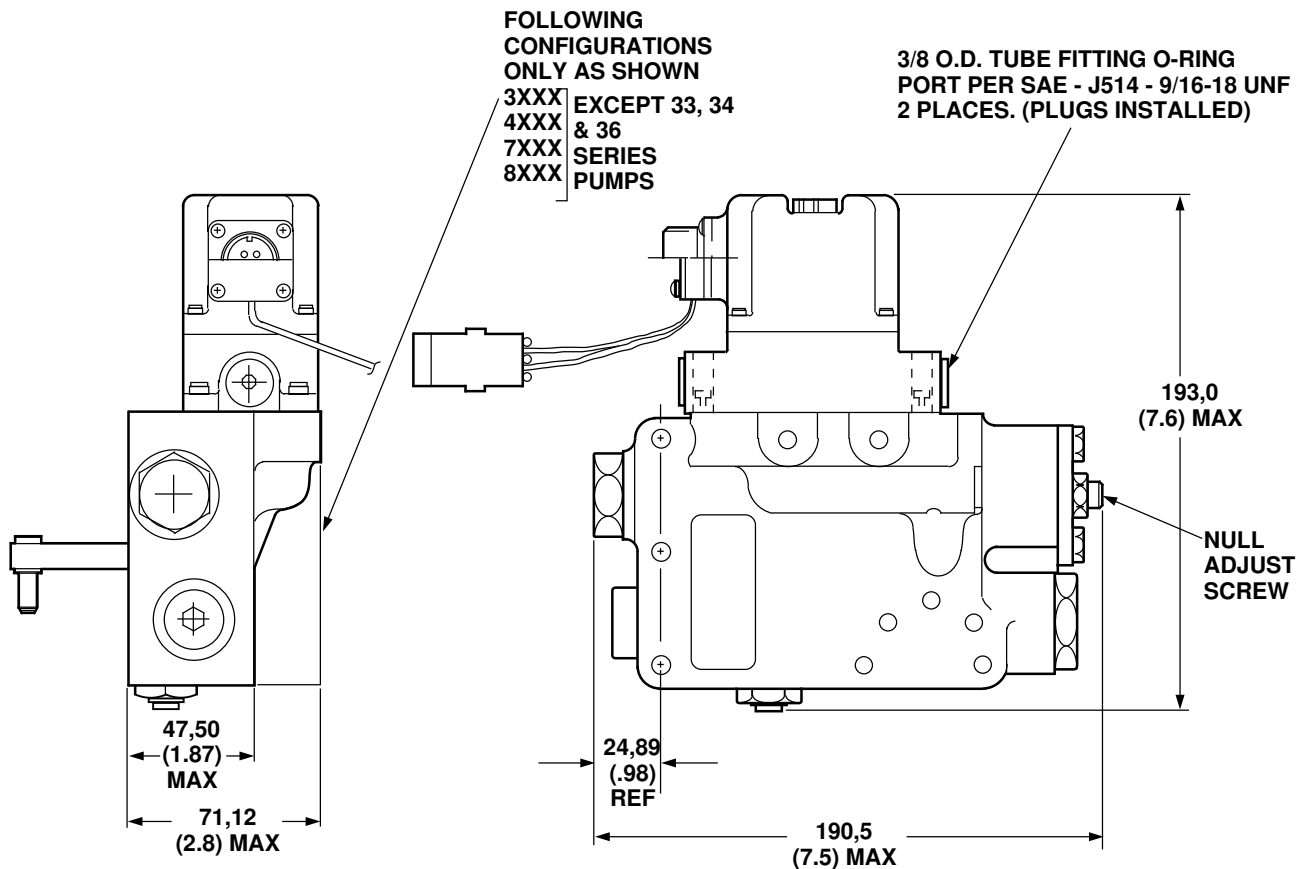

1445A

Dimensions of the MCV109A in Millimeters (Inches).

THEORY OF OPERATION

A command source such as a joy stick, control handle, or electronic controller applies a dc current signal to the pilot stage of the MCV109A. The input current commands the pilot's torque motor stage, a bridge network consisting of an armature mounted on a torsion pivot and suspended in the air gap of a magnetic field. Two permanent magnets polarized in parallel and a connecting plate form a frame for the magnetic bridge. At null the armature is centered in the air gap between the magnets' opposing poles by the equivalence of their magnetic forces and the null adjust centering springs. As input current rises, the end of the armature becomes biased either north or south, depending on the direction of the current. The resulting armature movement is determined by the amperage of control current, the spring constant and the differential pressure feedback forces explained below. See Internal Workings Schematic.

The magnetic bridge output, flapper torque, in turn controls the hydraulic bridge ratio. At null, the flapper is centered between two nozzles. Upstream from each nozzle is an orifice which provides a nominal pressure drop when the system is at null. Between the nozzle and the orifice on each side is a control port. As the torque motor shifts the flapper away from one nozzle toward the other, a differential control pressure results, the high side being the one nearer the flapper. Fluid pressure rises on this side and moves the

flapper back towards null. When the torque output from the motor equals the torque output from the pressure feedback, the pilot system is in equilibrium. It is this pressure feedback that makes the pilot a stand-alone, closed loop, pressure control valve.

The second stage's null adjust is set with the modulating spring compressed to the equivalent of 95 psi, which is the amount of differential pressure required to move the actuator spool. This is a factory setting that determines the threshold point at which the motor will begin to destroke. By tightening or loosening the null adjust screw, the motor can be accurately phased with a pump.

As differential control pressure (C2-C1) rises beyond the 95 psi threshold, the actuator spool moves, pivoting the cross-link about its center. The pivoting cross-link pushes the porting spool in the opposite direction of the actuator spool. When the porting spool has moved far enough, oil is ported to the motor servo cylinder, moving the swashplate. As the swashplate moves, the drag linkage follows, pivoting the cross-link about the stationary end of the actuator spool, driving the porting spool back to its neutral position. Because the feedback signal is entered into the control loop after the command has been input, response time and accuracy are enhanced.

INTERNAL WORKINGS SCHEMATIC

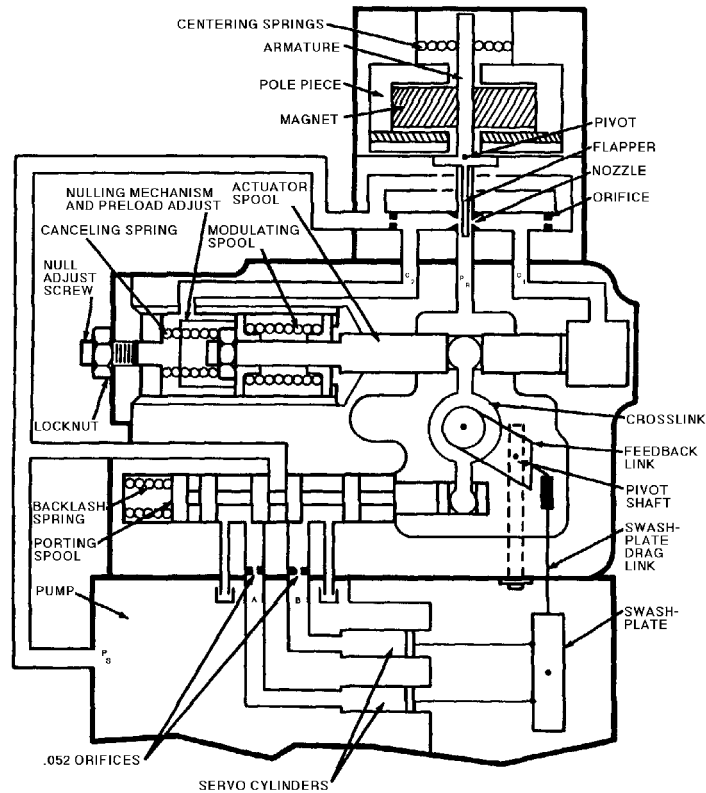

1303

Schematic of the Internal Workings of the MCV109A. Oil Paths Shown Externally for Clarity.

ENVIRONMENTAL

TEMPERATURE

The valve shall be functional and undamaged at oil temperatures of -40° to 121° C (-40° to 250° F). The valve shall meet performance specifications at oil temperatures of 21° to 82° C (70° to 180° F).

1. Cycling from 5 to 2000 Hz in each of the three axes.
2. Resonance dwell for one million cycles for each resonance point in each of the three axes.

Subject to acceleration levels of 1g to 46 gs. Acceleration level varies with frequency.

SHOCK

50 gs for 11 milliseconds. Three shocks in both directions of the three mutually perpendicular axes for a total of 18 shocks.

HUMIDITY

After being placed in a controlled atmosphere of 95% humidity at 49° C (120° F) for 10 days, the EDC will perform within specification limits.

VIBRATION

Withstands a vibration test designed for mobile equipment controls consisting of two parts:

DIMENSIONS

See Dimension drawing.

WIRING

Two wiring styles are available: MS and Packard connectors. The MS connector is Part Number K01314 (MS3102C14S-2P) and has four pins, only two of which are used (A and B) for single coil devices. See Wiring Schemes diagram for proper wire phasing and Connection diagram for pin locations. For both MS and Packard connectors, phasing is such that a positive voltage on the Red wire (Pin B) will cause a pressure rise at the C2 port for single coil valves.

1. 2 (or 4) 14 - 16 gauge sleeves
2. 2 (or 4) 18 - 20 gauge sleeves
3. 1 plastic housing
4. 2 (or 4) green cable seals (accept 2,2-2,8 mm wire diameter)
5. 2 (or 4) gray cable seals (accept 2,81-3,49 mm wire diameter)
6. 2 (or 4) blue cable seals (accept 3,50-4,21 mm wire diameter)

Included in the mating Packard connector bag assembly (which must be ordered separately) are:

See Ordering Information.

WIRING (continued)

To assemble the female tower connector, use the following directions:

1. Isolate the wires that extend from the command source to the EDC.
2. Strip back the insulation 5.5 millimeters on both wires.
3. Push a ribbed cable seal over each of the wires with the smaller-diameter shoulder of the seals toward the wire tip. Select the pair of seals that fits tightly over the wires. The distance from the tip of the wires to the first (nearest) rib should be 9.5 millimeters. Thus the installation should just protrude beyond the seal.
4. Select the larger of the two sets of pins, as measured at Dimension A (see Dimension A diagram), if using a 14-16 gauge wire. Choose the smaller if using 18-20 gauge. Place the wire into the socket so that the seal edge is pushed through and extends slightly beyond the circular tabs that hold it in place. Crimp in the locations shown (see Distance, Packard Connector diagram) with a Packard 12014254 crimp tool available from your local Packard distributor.
5. The distance from the back of the tangs to the furthest rib may not exceed 19.5 millimeters. See Distance, Packard Connector diagram.
6. Manually insert the assembled wires into the back end (large hole) of the plastic housing. Push until the wire detents with an audible click, then pull back slightly to ensure proper seating. (Observe the proper phasing of the wires when installing: black wire to "A" hole, red to "B", black to "C" and red to "D".) Terminals may be removed from the connector bodies with a Packard 12014012 removal tool.
7. Swing the holder down into the detented position to trap the wires in the housing. The third rib should be sealed into the housing.
8. Plug the shroud connector from the valve into the tower connector just constructed. They are sealed with a double (or quadruple) plug seal over the double (or quadruple) barrel of the tower assembly. The two connector halves should detent into each other. See Connector Parts Identified diagram.

DIMENSION A, PACKARD CONNECTOR

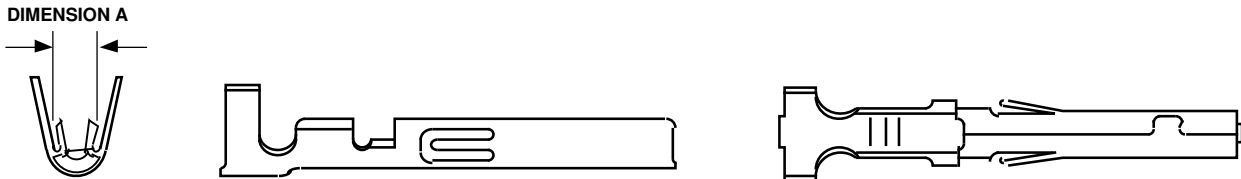

1123

Dimension A For Selecting Correct Terminal.

DISTANCE, PACKARD CONNECTOR

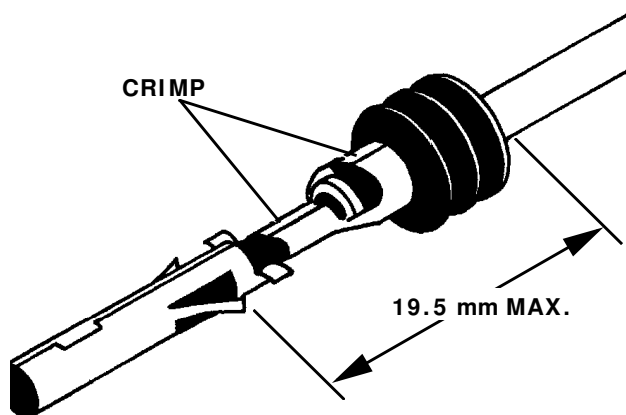

1077A

Distance From Tang to Third Rib of Packard Connector.

CONNECTOR PARTS IDENTIFIED, PACKARD CONNECTOR

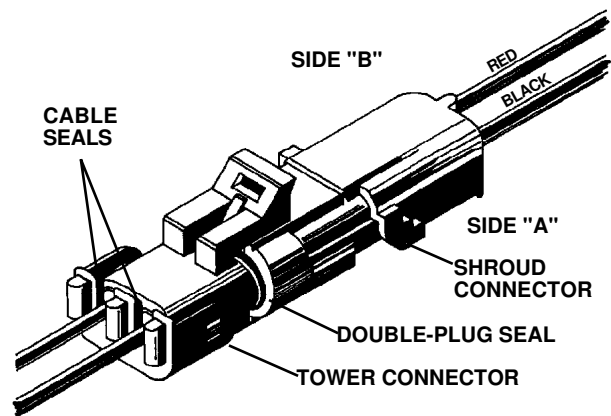

1078A

Interlocked Connector Halves With Parts Identified. Two Wire Connection Shown.

INSTALLATION

A highly reliable connection between the swashplate and the drag link is necessary for safe operation. An unreliable connection may result in loss of feedback with a resulting loss of control. Series 3X motors meet this requirement, but all Series 2X units not already equipped with an EDC or Hydraulic Displacement Control (HDC) must be retrofitted with the appropriate drag link, press fit pin and retaining ring, replacing the slip fit headless pin and E-rings used to attach the original drag link. Series 20 and 26 models require a spacer plate between the control and the motor housing.

Series 3X motors with Serial Number of 82-34-00000 or greater will accept the EDC without modification of the motor. These units have a clearance notch cast into the swashplate that provides additional room for link movement. Series 3X motors with Serial Numbers of less than 82-33-99999 may not be fitted with the EDC without modification of the swashplate by Danfoss.

Prior to mounting any control on a motor, ensure that both the control and the control feedback link are correct for the motor as evidenced by the series number stamped on the link and the part number labeled on the control body. See Table C and Warning.

TABLE C. THE FOLLOWING TABLE CORRELATES THE MOTOR SERIES NUMBER WITH THE SERIES NUMBER STAMPED ON THE SIDE OF THE CONTROL FEEDBACK LINK PROTRUDING FROM THE CONTROL.

SERIES	LINK MARKING
20,	20 (1/4 spacer)
21, 22	21, 22
23	23
24	24
25	25
26	26 (1 1/2 spacer)
27	27
33, 34, 36	33, 34, 36

WARNING

Exercise care when placing the valve on a surface before mounting on a transmission. Dropping or otherwise forcefully setting the valve with the linkage down may break the crosslink, resulting in a lack of response to command.

MOUNTING

Follow the procedure outlined below to attach the EDC to the motor.

REMOVING THE OLD HARDWARE

1. Thoroughly clean all external surfaces of the motor and control with steam or solvent. Blow dry.
2. Remove the existing control from the motor by removing the nine hex head screws from the housing. Slip the pin on the control linkage out of the end of the swashplate drag link. See Swashplate Drag Link diagram.
3. Remove the case drain fitting from the side of the motor on which the control was mounted.
4. Remove the E-ring from the inside end of the connecting pin. Use caution not to drop the E-ring into the housing during the removal. See Pin Connection diagram.
5. Remove the pin from the swashplate drag link and swashplate through the case drain port using a magnet or other tool. Remove the drag link. On some models it may be necessary to hold the swashplate off neutral to align it with the case drain hole. See Swashplate Assembly diagram.

SWASHPLATE DRAG LINK



1124B

Swashplate Drag Link/Control Feedback Link Connection Between Original Control and Motor.

PIN CONNECTION

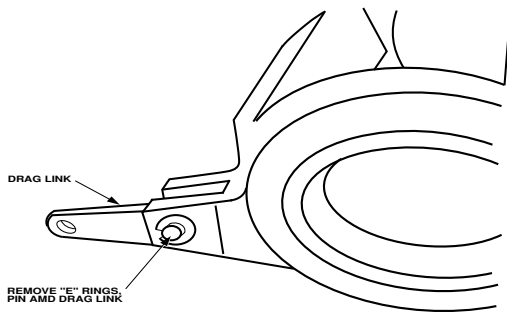

1125C

Location of Swashplate Assembly in Motor Housing.

SWASHPLATE ASSEMBLY

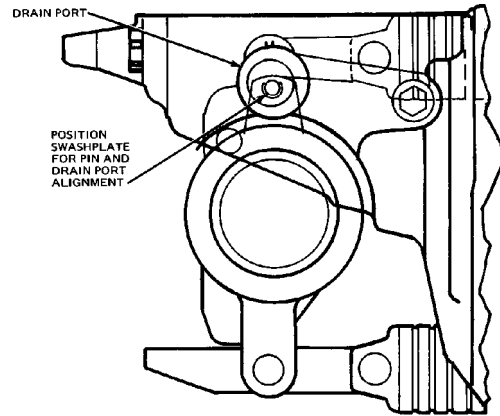

1126B

Pin Connection to Swashplate.
Shown Disassembled for Clarity.

MOUNTING (continued)

MOUNTING THE NEW HARDWARE

1. Recheck the series number on the control feedback link to ensure that it is compatible with the motor. Follow the procedure outlined below to install the linkage. See Parts Location Drawing.
 - A. Unscrew the bushing, using care not to damage its O-ring. See Swashplate Assembly diagram.
 - B. Install the new linkage assembly shaft through the swashplate feedback shaft hole. Place the ball in the crosslink ball cavity.

WARNING

The control and feedback link must have the proper identification in order to be installed. Installing a control with an improper control feedback link can result in a control failure which can cause the motor swashplate to move to full angle and remain there independent of signal input.

Do not attempt to install an EDC on a motor for which it was not originally designed without changing the link-and-ball assembly. Merely changing the swashplate drag link is inadequate. See Ordering Information for the necessary link-and-ball assembly number. In no case should a valve originally built for a Series 2X motor be used on a Series 3X motor.

- C. Lubricate the shaft O-ring and replace the bushing over the shaft. Torque to the body (10 - 15 foot pounds) so that the feedback shaft extends through the bushing.
 - D. Install the retaining ring in the groove on the shaft.
2. Align one end of the replacement swashplate drag link with the holes in the swashplate link arms.
 3. Insert the press fit pin through the case drain port to trap the drag link in the swashplate clevis. It will be necessary to tap the pin into place until the head of the pin is flush to the clevis.
 4. Install the retaining ring by forcing it onto the tapered end of the pin until it locks into the groove on the pin shaft. Again, use caution not to drop any components into the motor housing.
 5. Install the supplied spacer between the control and the motor housing. If the motor is a 20 Series, the spacer is one-quarter inch thick; if it is a 26 Series, the spacer is 1 1/2 inch thick. Other series' do not require a spacer. One gasket and 3 O-rings must be installed on the under side of the spacer.
 6. Install one .052-inch diameter orifice in each servo passage if normal swashplate response is desired. Two orifices are used instead of the single orifice used in the charge supply passage of manual controls. Install 3 O-rings and a gasket. If a spacer is used, there should now be 6 O-rings and 2 gaskets in place.
 7. Engage the pin on the control in the drag link and swing the control into place against the motor housing. The drag link should be on the cylinder block side of the swashplate. Install the seven mounting screws and tighten to 10-11 foot pounds of torque.

PARTS LOCATION DRAWING

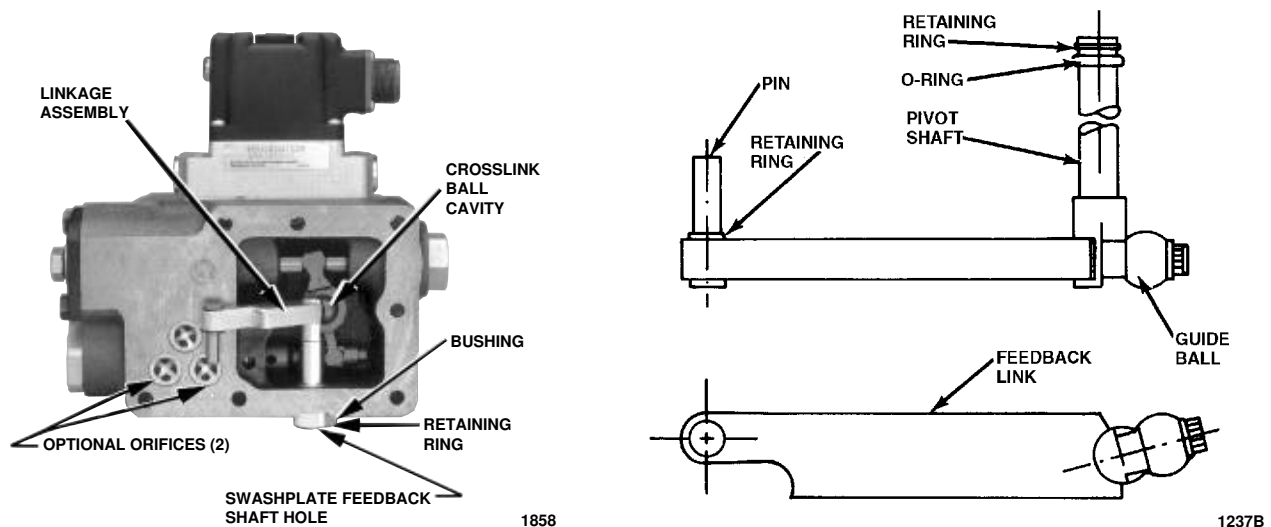

Location of Parts When Installing a New Link and Ball Assembly. Separate Assembly Parts Shown for Information Only; Do Not Attempt to Disassemble.

MOTOR NEUTRAL ADJUSTMENT

Each MCV109 is factory calibrated so that the motor will begin to destroke from 18° at the specified threshold input current (see Technical Data section) to 6° which is full destroke. This setting should not require adjustment.

If for some reason adjustment of neutral is necessary, a turn of the null adjustment screw will vary the current/swashplate

angle curve (see Performance Curve diagram) vertically. A clockwise turn will reduce the angle at which the swashplate begins to destroke from 18° to a smaller angle. Physical stops prevent the motor from destroking below 6°. A counterclockwise turn increases the fully-destroked angle above 6°. Physical stops prevent the swashplate from exceeding 18°.

MOTOR THRESHOLD ADJUSTMENT

Use the following procedure to bring the hydraulic motor to a threshold setting. The procedure describes "stages" of the transmission, so that the motor starts to destroke just as the pump reaches full stroke. This ensures a smooth, continuous rise in motor shaft speed as command increases.

If a tachometer is unavailable, or if for some other reason the following procedure is impractical, similar results can be obtained by running the machine at different MCV109A threshold adjustments. There should be no "dead spots" in which increased command gives no increased speed. Nor should there be spots in which increased command gives a faster rise in speed than at high and low command extremes.

WARNING

To adjust neutral requires operating the pump. Take the necessary safety precautions such as having unnecessary personnel stand away from the machine. Maximum system pressure may occur upon start up, and the machine may move. Ensure that the operator is not in a position to be injured should the machine move.

1. Disconnect the wires connecting the EDC pilot of the MCV109 EDC-MV on the motor.
2. Install a mechanical or photoelectric tachometer on the output shaft of the hydraulic motor.

3. Run the EDC electrical (or HDC-PV hydraulic) command source to maximum.
4. Slowly reduce the command source until the motor shaft starts to decrease speed as shown by the tachometer. This point represents full pump output. Note the RPM indication level on the tachometer. Note the command source position and the engine speed.
5. Reconnect the wires to the EDC-MV. Re-start the hydrostatic transmission. Using a 9/16-inch wrench, loosen the hex lock nut on the null adjustment screw.
6. Using a 3/16 inch internal hex wrench, slowly turn the null adjustment screw counterclockwise until the tachometer indicates the full pump output from Step 4. (Note: Clockwise null adjust rotation increases shaft output speed.) Then turn the screw clockwise until shaft speed just starts to increase.
7. Hold the adjustment screw and securely tighten the hex lock nut on the adjustment screw to 14-18 foot-pounds.
8. Run the system briefly to ensure that it operates proportionally. Swashplate movement can be verified by watching movement of the swashplate feedback shaft, shown in Parts Location Drawing.

CUSTOMER SERVICE

NORTH AMERICA

ORDER FROM

Danfoss (US) Company
Customer Service Department
3500 Annapolis Lane North
Minneapolis, Minnesota 55447
Telephone: (763) 509-2084
Fax: (763) 559-0108

DEVICE REPAIR

For devices in need of repair, include a description of the problem, a copy of the purchase order and your name, address and telephone number.

RETURN TO

Danfoss (US) Company
Return Goods Department
3500 Annapolis Lane North
Minneapolis, Minnesota 55447

EUROPE

ORDER FROM

Danfoss (Neumünster) GmbH & Co.
Customer Service Department
Krokamp 35
Postfach 2460
D-24531 Neumünster
Germany
Telephone: 49-4321-8710
Fax: 49-4321-871-284