

6 5 4 3 2 1

D

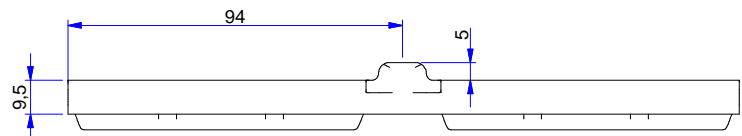
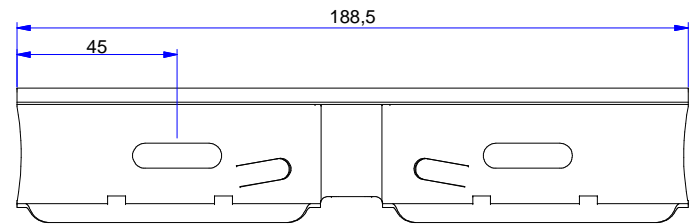
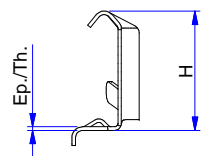
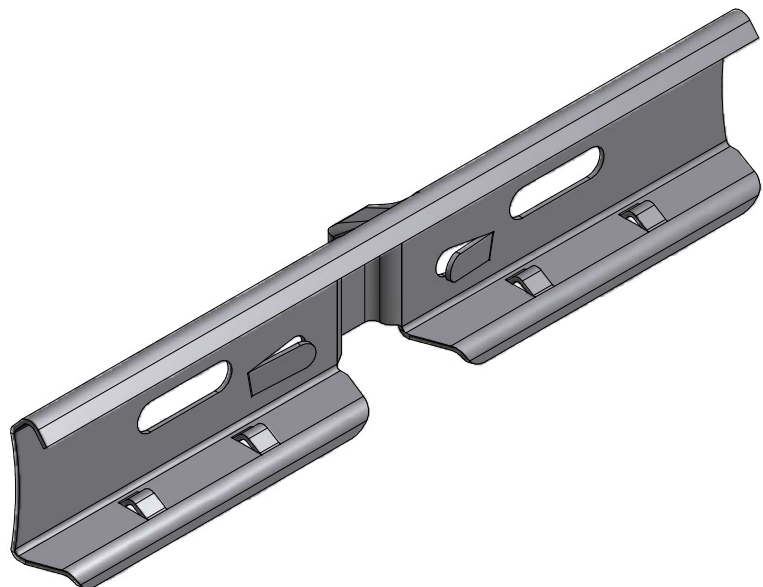

C

Chemin de câbles fil  
(Mesh tray)

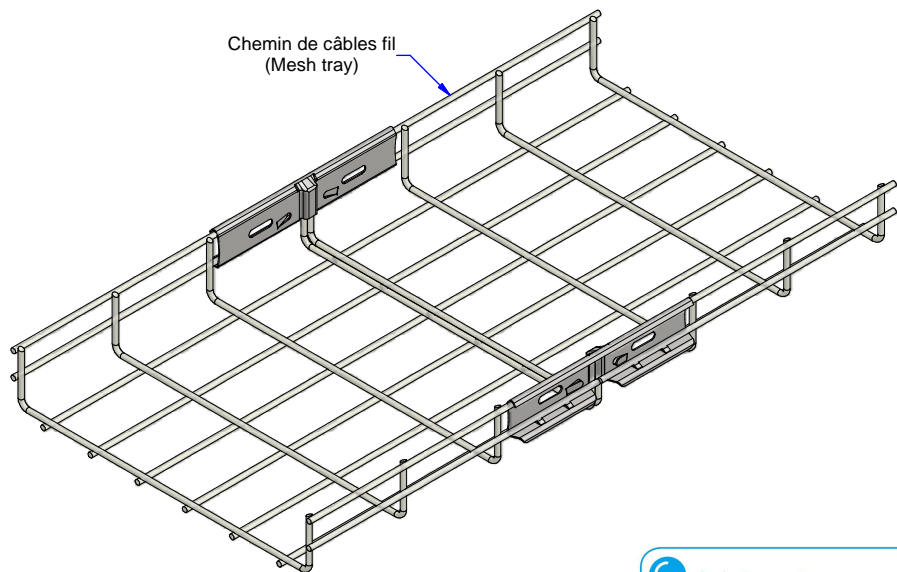

B

Description	Code	Masse/Weight Kg/p	Ep./Th. mm	H mm
RAPIDFIL ZM	553030	0,096	1,00	34

A

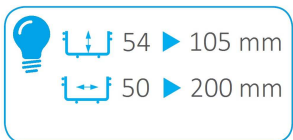

www.niedaxfrance.fr

**ZM** : High performance coated zinc according to NF A 91102  
**ZM** : Revêtement haute tenue corrosion suivant NF A 91102

ECLISSE RAPIDFIL ZM RAPIDFIL COUPLER ZM		<b>CE</b>
ASSISTANCE TECHNIQUE +33 (0)1 55 95 92 17 pole.technique@niedax.fr		<b>NIEDAX</b> France
FT02493		

6 5 4 3 2 1

D

C

B

A