



UL technical data

Rated operational voltage AC (UL)

V 600

Dimensions

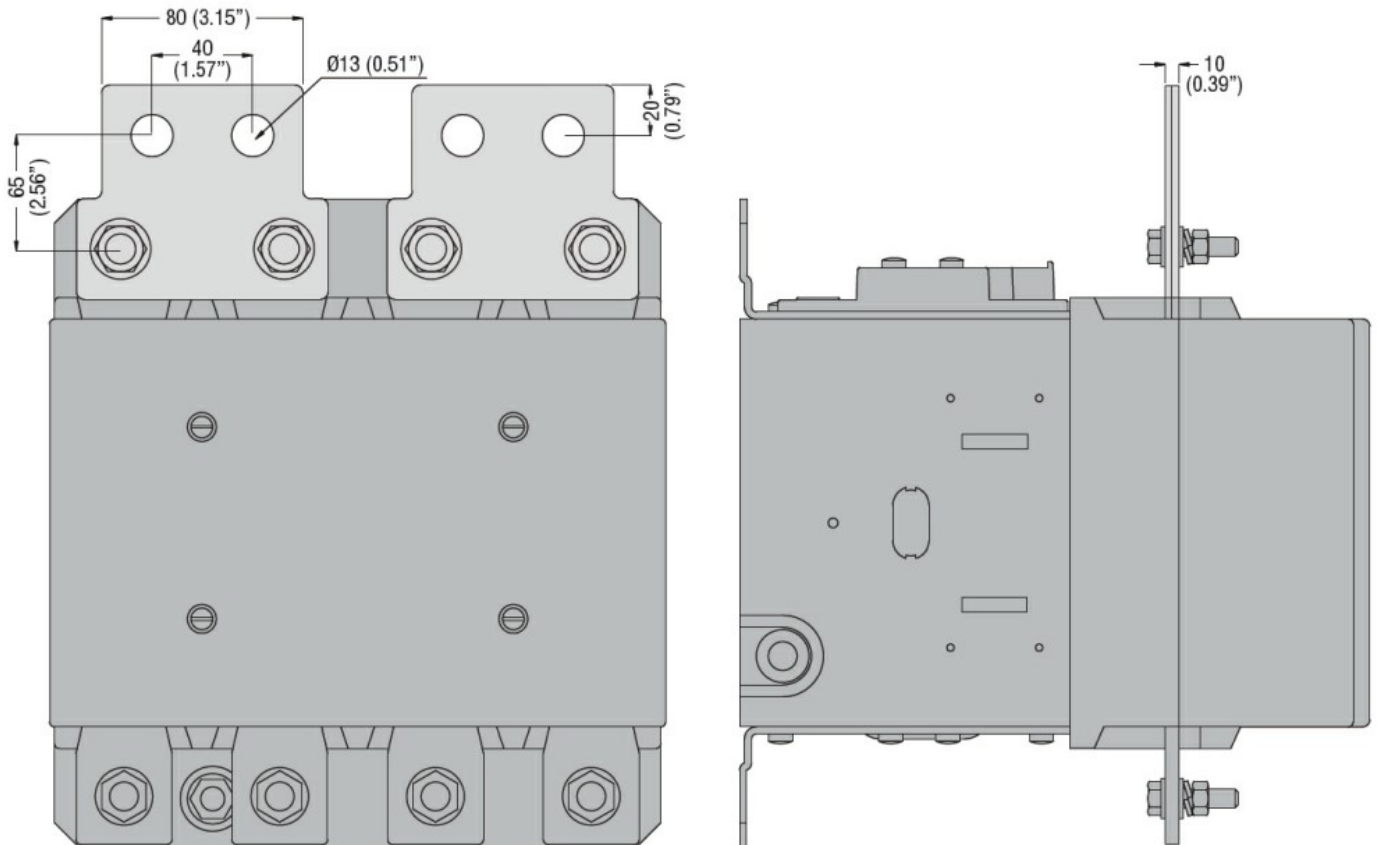

Certifications and compliance

Certificates

/

ETIM classification

ETIM 8.0

EC002498 -  
Accessories/spare  
parts for low-  
voltage switch  
technology