



Electrical features

Maximum operating current ($\leq 440V$) A 9

Contact characteristics

Operational current Ie AC-3 ($\leq 440V \leq 55^\circ C$) A 9

Rated operational power AC-3 ($T \leq 55^\circ C$)	Voltage	Power (kW)	Current (A)
	230V	2.2	9
	400V	4	9
	415V	4.3	9
	440V	4.5	9
	500V	5	9

Built-in auxiliary contacts NO 0
NC 1

UL technical data

Maximum UL/CSA horsepower ratings single-phase 110V-120V HP 0.5
220V-240V HP 1.5

Maximum UL/CSA horsepower ratings three-phase, 3-pole 200V-208V HP 2
220V-240V HP 3
440V-480V HP 5

Mechanical features

Terminals type Clamp screw

Weight g 400

Dimensions

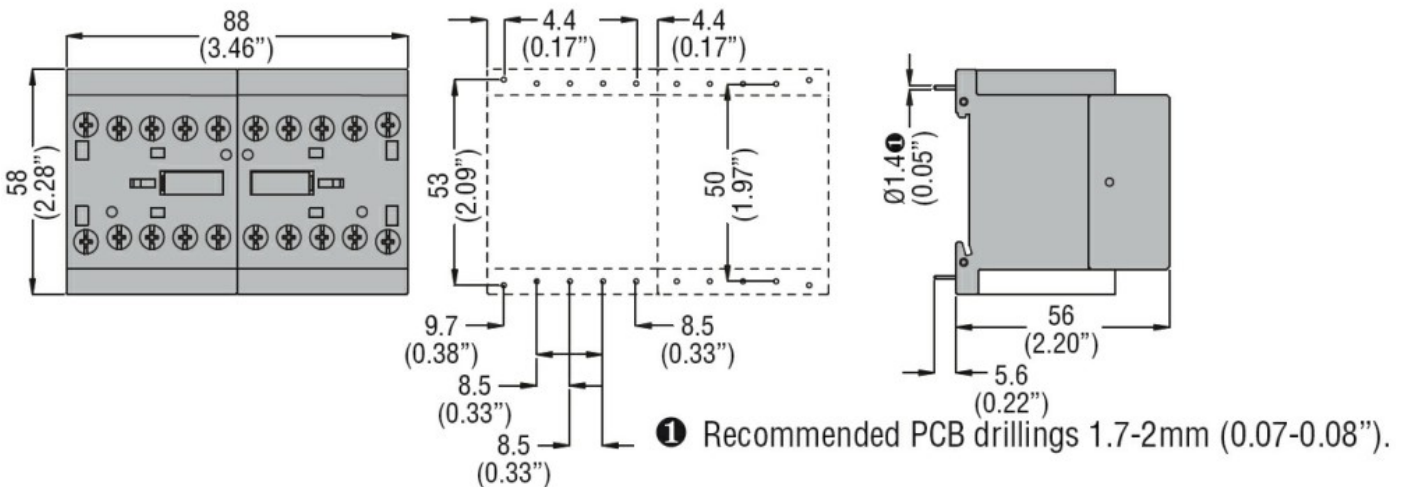

Wiring diagrams

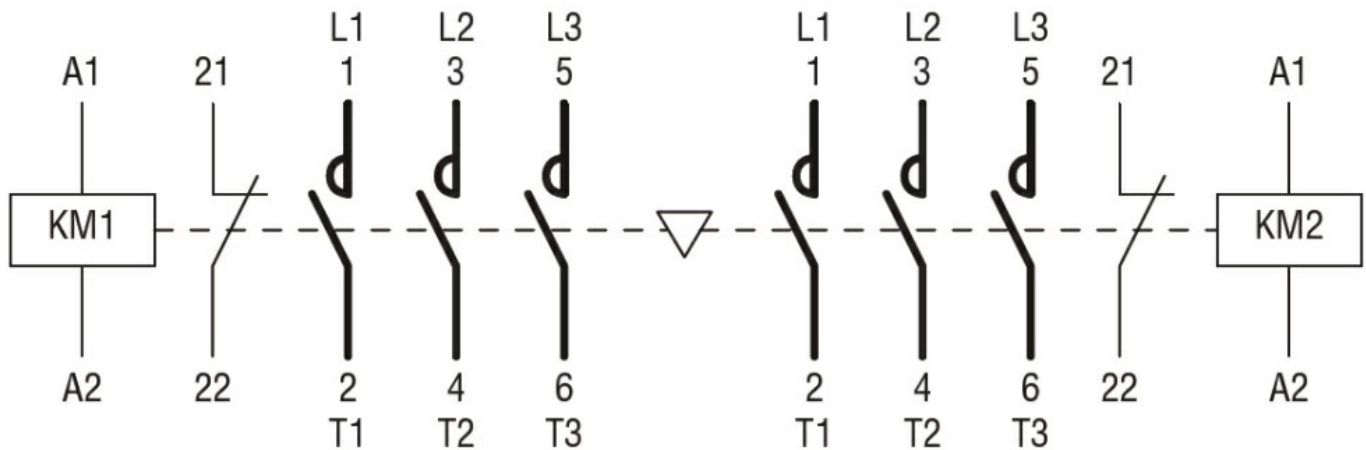

Certifications and compliance

Compliance

IEC/EN 60947-1

IEC/EN 60947-4-1

UL508 CSA C22.2 n° 14

Certificates

cULus

ETIM classification

ETIM 8.0

EC001037 -
Motor
starter/Motor
starter
combination