

General characteristics

Switching diagram	20 - Dahlander motor 2-speed reversing switch
N° of elements	6
Mounting form	O - Rear mounting with black handle

Contact characteristics

Rated insulation voltage U_i	IEC/EN	V	690	
	UL/CSA	V	600	
Rated impulse withstand voltage U_{imp}		kV	6	
Conventional free air thermal current I_{th}	IEC/EN	A	40	
	UL/CSA	A	50	
Rated operational voltage		V	480	
Rated operational impulse voltage		kV	4	
Maximum fuse size for short-circuit protection I_n (gG)	10kA	A	40	
	15kA	A	40	
	25kA	A	40	
	50kA	A	40	
	63kA	A	40	
Rated short time current I_{cw}	1s	kA	1000	
			10/5 mA/V	
Conductivity				
Operational current I_e IEC/EN	AC1/AC21A		A	40
	AC15			
	110V	A	25	
	220/230V	A	22	
	380/400V	A	12	
	660/690V	A	2	
Rated operational power in AC	Three-phase AC-3			
	220/230V	kW	8	
	380/440V	kW	15	
	500/690V	kW	15	
	Single-phase AC-3			
	110V	kW	3	
	220/230V	kW	6.5	
	380/440V	kW	8	
	Three-phase AC23A			
	220/230V	kW	8	
	380/440V	kW	18.5	
	500/690V	kW	22	
Single-phase AC23A				
110V	kW	3		
220/230V	kW	6		
380/440V	kW	11		
Rated operational current in DC				

DC21A	48V	A	40
	60V	A	40
	110V	A	6
	220V	A	0.9
<hr/>			
DC23A (poles in series)	24V	A	40 (1)
	48V	A	40 (2)
	60V	A	40 (3)
	110V	A	20 (3)
	220V	A	12 (4)
<hr/>			
DC13	24V	A	40
	48V	A	32
	60V	A	16
	110V	A	3

Power dissipation		W	2.0
-------------------	--	---	-----

Mechanical features

Terminals screw			M4
-----------------	--	--	----

Tightening torque for terminals max		Nm	1.2
-------------------------------------	--	----	-----

Conductor size

AWG - Rigid cable	min	AWG	16
	Max	AWG	8

AWG - Flexible cable	min	AWG	16
	Max	AWG	10

Conductor size (IEC) - Flexible cable	min	mm ²	1.5
	Max	mm ²	6

Conductor size (IEC) - Rigid cable	min	mm ²	1.5
	Max	mm ²	10

Mechanical life		cycles	5x10 ⁶
-----------------	--	--------	-------------------

UL technical data

Motor power for direct-on-line control for three-phase motor	120V	HP	5
	240V	HP	10
	480V	HP	20
	600V	HP	20

for single-phase motor	120V	HP	2
	240V	HP	5

Ambient conditions

Temperature	Operating temperature	min	°C	-25
		max	°C	+55
	Storage temperature	min	°C	-40
		max	°C	+70

Resistance & Protection

Frontal IP degree			IP40
-------------------	--	--	------

Terminals IP degree

IP00

Dimensions



Series	Dimensions								L Number of elements											
	ØA	C	ØD	ØD2	E	H	ØK	ØN	1	2	3	4	5	6	7	8	9	10	11	12
7GN12	48	39.5	39	5	26.5	5	36	6	38.1	47.8	57.5	67.2	76.9	86.6	96.3	106	115.7	125.4	135.1	144.8
7GN20	48	39.5	39	5	26.5	5	36	6	38.1	47.8	57.5	67.2	76.9	86.6	96.3	106	115.7	125.4	135.1	144.8
7GN25	48	39.5	43	5	26.5	5	36	6	42.5	56.1	69.7	83.3	96.9	110.5	124.1	137.7	151.3	164.9	178.5	192.1
7GN32	65	53	58	5	34.5	5.5	48	7	48.5	63.6	78.7	93.8	108.9	124	139.1	154.2	169.3	184.4	199.5	214.6
7GN40	65	53	58	5	34.5	5.5	48	7	48.5	63.6	78.7	93.8	108.9	124	139.1	154.2	169.3	184.4	199.5	214.6
7GN63	65	53	62	6	34.5	7.5	68	7	53.3	71.4	89.5	107.6	125.7	143.8	161.9	180	198.1	216.2	234.3	252.4
7GN125	90	70.5	86	6	41.4	7.5	68	9	74.8	103.9	133	162.1	191.2	220.3	249.4	278.5	307.6	336.7	365.8	394.9

Wiring diagrams

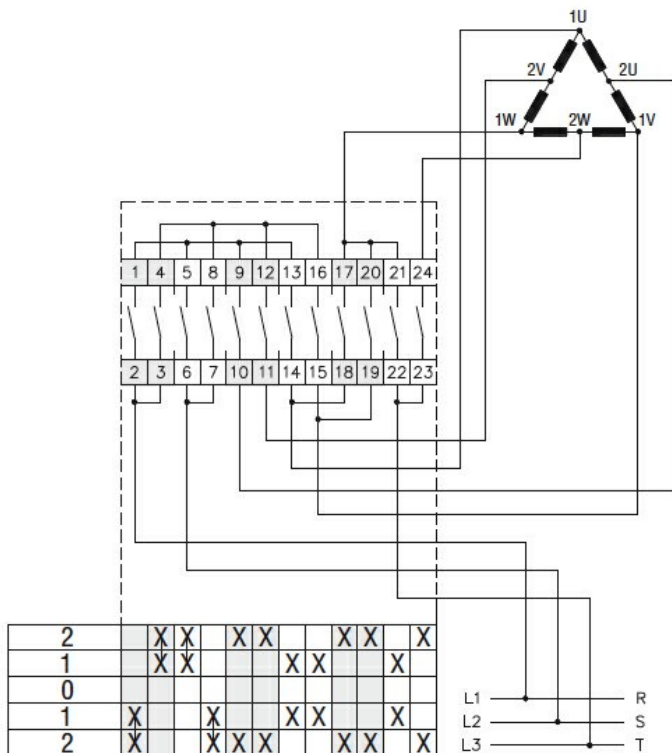

Certifications and compliance

Compliance

CSA C22.2 n° 14
IEC/EN/BS 60947-1
IEC/EN/BS 60947-3
IEC/EN/BS 60947-5-1
UL60947-4-1

Certificates

cCSAus

EAC

UL

ETIM classification

ETIM 8.0

EC001029 -
Selector switch,
complete