

General characteristics

Switching diagram	20 - Dahlander motor 2-speed reversing switch
N° of elements	6
Mounting form	O - Rear mounting with black handle

Contact characteristics

Rated insulation voltage U_i	IEC/EN	V	690	
	UL/CSA	V	600	
Rated impulse withstand voltage U_{imp}		kV	6	
Conventional free air thermal current I_{th}	IEC/EN	A	63	
	UL/CSA	A	60	
Rated operational voltage		V	480	
Rated operational impulse voltage		kV	4	
Maximum fuse size for short-circuit protection I_n (gG)	10kA	A	63	
	15kA	A	63	
	25kA	A	63	
	50kA	A	63	
	63kA	A	63	
Rated short time current I_{cw}	1s	kA	1600	
			10/5 mA/V	
Conductivity			10/5 mA/V	
Operational current I_e IEC/EN	AC1/AC21A	A	63	
	AC15			
	110V	A	32	
	220/230V	A	25	
	380/400V	A	15	
	660/690V	A	4	
Rated operational power in AC	Three-phase AC-3	220/230V	kW	11
		380/440V	kW	18.5
		500/690V	kW	18.5
	Single-phase AC-3	110V	kW	3.7
		220/230V	kW	6.5
		380/440V	kW	11.5
	Three-phase AC23A	220/230V	kW	12.5
		380/440V	kW	30
		500/690V	kW	30
	Single-phase AC23A	110V	kW	3.7
		220/230V	kW	7.5
		380/440V	kW	12.5
Rated operational current in DC				

DC21A	48V	A	63
	60V	A	50
	110V	A	8
	220V	A	1
<hr/>			
DC23A (poles in series)	24V	A	50 (1)
	48V	A	50 (2)
	60V	A	50 (3)
	110V	A	25 (3)
	220V	A	15 (4)
<hr/>			
DC13	24V	A	63
	48V	A	40
	60V	A	28
	110V	A	3.3

Power dissipation	W	3.4
-------------------	---	-----

Mechanical features

Terminals screw	M5
Tightening torque for terminals max	Nm 2

Conductor size

AWG - Rigid cable	min	AWG	14
	Max	AWG	6

AWG - Flexible cable	min	AWG	14
	Max	AWG	8

Conductor size (IEC) - Flexible cable	min	mm ²	2.5
	Max	mm ²	10

Conductor size (IEC) - Rigid cable	min	mm ²	2.5
	Max	mm ²	16

Mechanical life	cycles	5x10 ⁶
-----------------	--------	-------------------

UL technical data

Motor power for direct-on-line control for three-phase motor	120V	HP	7.5
	240V	HP	15
	480V	HP	25
	600V	HP	25
	<hr/>		
for single-phase motor	120V	HP	3
	240V	HP	10

Ambient conditions

Temperature	Operating temperature	min	°C	-25
		max	°C	+55
	<hr/>			
	Storage temperature	min	°C	-40
		max	°C	+70

Resistance & Protection

Frontal IP degree	IP40
-------------------	------

Terminals IP degree

IP00

Dimensions



Series	Dimensions								L Number of elements											
	□A	C	ØD	ØD2	E	H	□K	□N	1	2	3	4	5	6	7	8	9	10	11	12
7GN12	48	39.5	39	5	26.5	5	36	6	38.1	47.8	57.5	67.2	76.9	86.6	96.3	106	115.7	125.4	135.1	144.8
7GN20	48	39.5	39	5	26.5	5	36	6	38.1	47.8	57.5	67.2	76.9	86.6	96.3	106	115.7	125.4	135.1	144.8
7GN25	48	39.5	43	5	26.5	5	36	6	42.5	56.1	69.7	83.3	96.9	110.5	124.1	137.7	151.3	164.9	178.5	192.1
7GN32	65	53	58	5	34.5	5.5	48	7	48.5	63.6	78.7	93.8	108.9	124	139.1	154.2	169.3	184.4	199.5	214.6
7GN40	65	53	58	5	34.5	5.5	48	7	48.5	63.6	78.7	93.8	108.9	124	139.1	154.2	169.3	184.4	199.5	214.6
7GN63	65	53	62	6	34.5	7.5	68	7	53.3	71.4	89.5	107.6	125.7	143.8	161.9	180	198.1	216.2	234.3	252.4
7GN125	90	70.5	86	6	41.4	7.5	68	9	74.8	103.9	133	162.1	191.2	220.3	249.4	278.5	307.6	336.7	365.8	394.9

Wiring diagrams

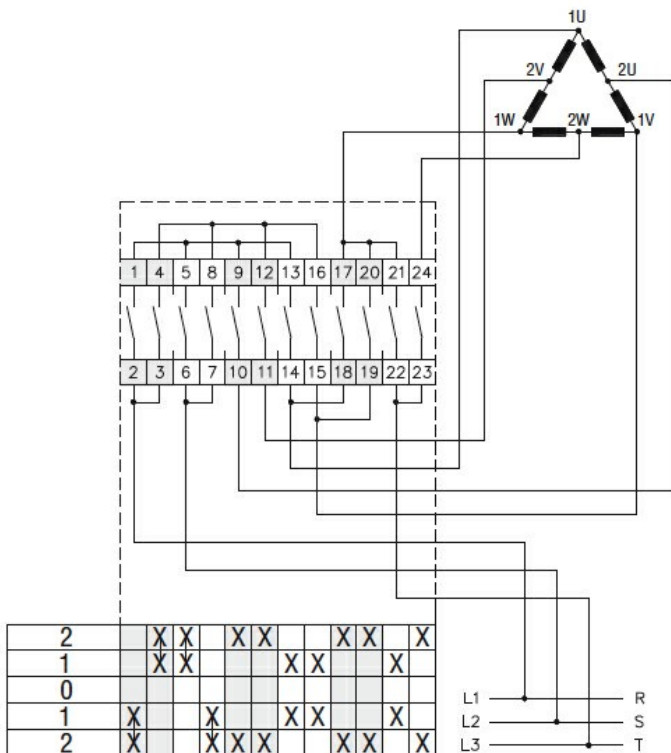

Certifications and compliance

Compliance

CSA C22.2 n° 14
IEC/EN/BS 60947-1
IEC/EN/BS 60947-3
IEC/EN/BS 60947-5-1
UL60947-4-1

Certificates

cCSAus

EAC

UL

ETIM classification

ETIM 8.0

EC001029 -
Selector switch,
complete