



General characteristics

Diameter	mm - inch	70 / 2.75
Material		Metal

Mechanical features

Weight	g	184
--------	---	-----

Dimensions

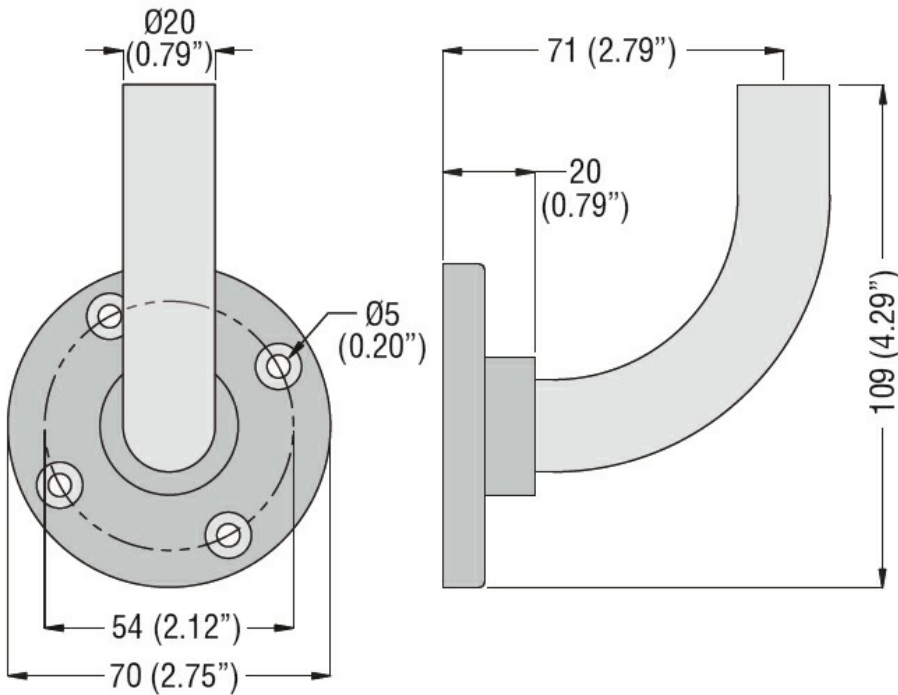

Certifications and compliance

Compliance	/
------------	---

Certificates	/
--------------	---

ETIM classification

ETIM 8.0	EC001153 - Wall bracket for signal tower
----------	--