



General characteristics

Diameter	mm - inch	62 / 2.44 - 70 / 2.75
Colour		Black
Material		Plastic

Mechanical features

Weight	g	45
--------	---	----

Dimensions

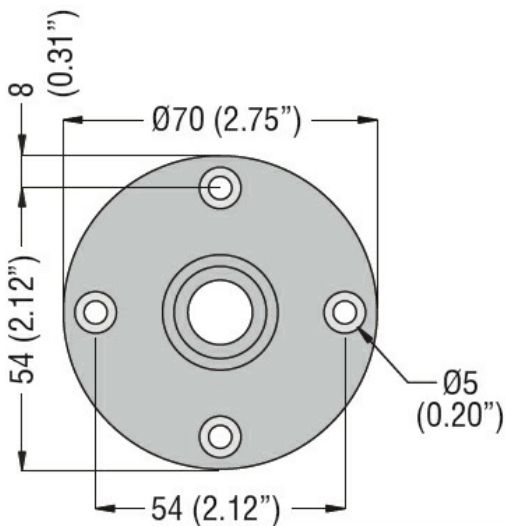
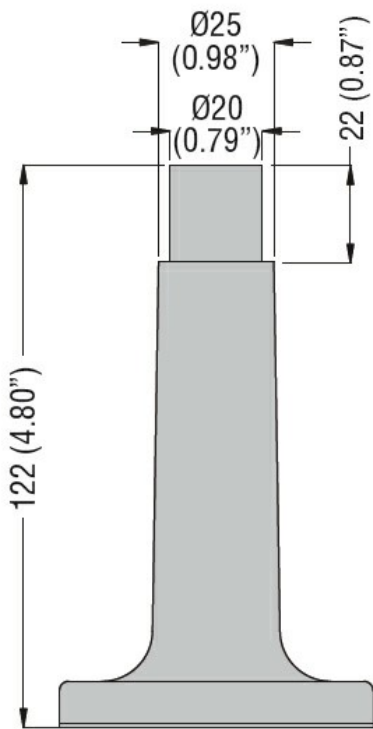

Certifications and compliance

Compliance

/

Certificates

/

ETIM classification

ETIM 8.0

EC001259 -  
Stand for signal  
tower with tube