



Power supply

Rated voltage U_s

min	VAC	100
Max	VAC	240 \pm 10%

Operational frequency

min	Hz	50 \pm 5%
max	Hz	60 \pm 5%

Power consumption

Max	VA	150
Max	W	77

Power dissipation Max

W 9

Internal fuse

A 2

Charging cycle

Reference standards

IEC62368-1

Battery type

lead-acid

Battery voltage

VDC 24

Charging voltage (U_c)

27.2 VDC

Charging current (I_c)

A 2.5

Charging current adjustment

% I_c Fixed

Protections

Main supply fuse;
charging
inhibition due to:
1. Short circuit at
battery terminals;
2. Reverse
battery polarity; 3.
Low voltage at
battery poles; 4.
Output overload.

Indications

LED reverse battery polarity

Yes

Alarm output circuit

Output type

1 relay

Rated capacity

AC1: 3A 250VAC

Mechanical features

Housing type

Modular DIN rail
mounting

Terminals type

Fixed

Fixing

35mm DIN rail or
Screw fixing

Weight

g 332

Ambient conditions

Temperature

Operating temperature

min	°C	-40
max	°C	+51

Storage temperature

min	°C	-40
max	°C	+85

Protection degree

IP20

Dimensions

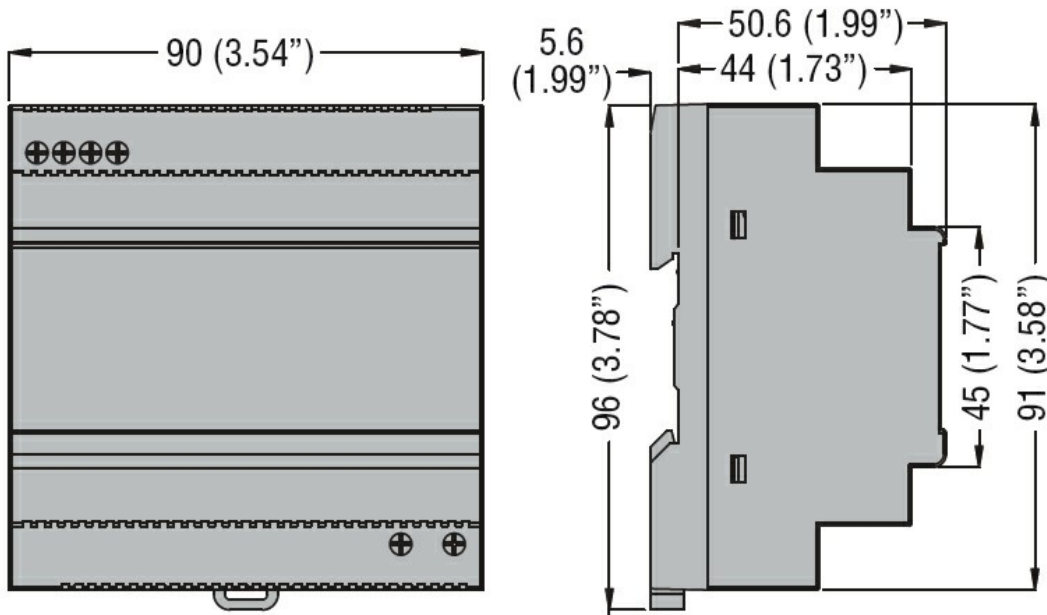

Wiring diagrams

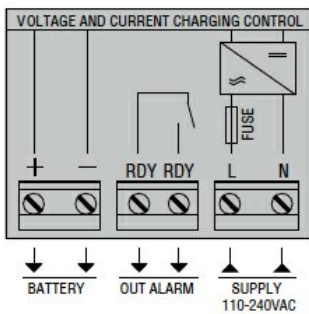

Certifications and compliance

Compliance

IEC/EN/BS 60100-6-2

IEC/EN/BS 61000-6-3

IEC/EN/BS 62368-1

Certificates

cURus

EAC

ETIM classification

ETIM 8.0

EC000359 -
Universal charger