



Contact characteristics

| | | |
|--|--------------------|--------|
| Number of poles | Nr. | 4 |
| Rated insulation voltage U _i IEC/EN | V | 690 |
| Rated impulse withstand voltage U _{imp} | kV | 6 |
| Operational frequency | min | Hz 25 |
| | max | Hz 400 |
| IEC Conventional free air thermal current I _{th} ≤ 40°C | A | 32 |
| Operational current I _e | AC-1 (≤40°C) | A 32 |
| | AC-1 (≤55°C) | A 26 |
| | AC-1 (≤70°C) | A 23 |
| | AC-3 (≤440V ≤55°C) | A 18 |
| | AC-4 (400V) | A 8.5 |
| Rated operational power AC-1 (T≤40°C) | 230V | kW 12 |
| | 400V | kW 21 |
| | 500V | kW 26 |
| | 690V | kW 36 |
| IEC max current I _e in DC1 with L/R ≤ 1ms with 1 poles in series | ≤24V | A 17 |
| | 48V | A 15 |
| | 75V | A 15 |
| | 110V | A 6 |
| | 220V | A – |
| IEC max current I _e in DC1 with L/R ≤ 1ms with 2 poles in series | ≤24V | A 20 |
| | 48V | A 20 |
| | 75V | A 20 |
| | 110V | A 13 |
| | 220V | A 1 |
| IEC max current I _e in DC1 with L/R ≤ 1ms with 3 poles in series | ≤24V | A 22 |
| | 48V | A 22 |
| | 75V | A 20 |
| | 110V | A 16 |
| | 220V | A 11 |
| IEC max current I _e in DC1 with L/R ≤ 1ms with 4 poles in series | ≤24V | A 22 |
| | 48V | A 22 |
| | 75V | A 20 |
| | 110V | A 18 |
| | 220V | A 13 |
| IEC max current I _e in DC3-DC5 with L/R ≤ 15ms with 1 poles in series | ≤24V | A 12 |

| | | | |
|--|-----------------|------------------|------|
| | 48V | A | 11 |
| | 75V | A | 11 |
| | 110V | A | 2 |
| | 220V | A | – |
| <hr/> | | | |
| IEC max current I _e in DC3-DC5 with L/R ≤ 15ms with 2 poles in series | ≤24V | A | 15 |
| | 48V | A | 13 |
| | 75V | A | 13 |
| | 110V | A | 8 |
| | 220V | A | 2 |
| <hr/> | | | |
| IEC max current I _e in DC3-DC5 with L/R ≤ 15ms with 3 poles in series | ≤24V | A | 18 |
| | 48V | A | 18 |
| | 75V | A | 16 |
| | 110V | A | 12 |
| | 220V | A | 6 |
| <hr/> | | | |
| IEC max current I _e in DC3-DC5 with L/R ≤ 15ms with 4 poles in series | ≤24V | A | 18 |
| | 48V | A | 18 |
| | 75V | A | 16 |
| | 110V | A | 13 |
| | 220V | A | 8 |
| <hr/> | | | |
| Short-time allowable current for 10s (IEC/EN60947-1) | | A | 200 |
| <hr/> | | | |
| Protection fuse | gG (IEC) | A | 32 |
| | aM (IEC) | A | 20 |
| <hr/> | | | |
| Making capacity (RMS value) | | A | 180 |
| <hr/> | | | |
| Breaking capacity at voltage | 440V | A | 144 |
| | 500V | A | 120 |
| | 690V | A | 94 |
| <hr/> | | | |
| Resistance per pole (average value) | | mΩ | 2.5 |
| <hr/> | | | |
| Power dissipation per pole (average value) | I _{th} | W | 2.6 |
| | AC-3 | W | 0.8 |
| <hr/> | | | |
| Tightening torque for terminals | min | Nm | 1.5 |
| | max | Nm | 1.8 |
| | min | I _{bin} | 1.1 |
| | max | I _{bin} | 1.5 |
| <hr/> | | | |
| Tightening torque for coil terminal | min | Nm | 0.8 |
| | max | Nm | 1 |
| | min | I _{bin} | 0.8 |
| | max | I _{bin} | 0.74 |
| <hr/> | | | |
| Max number of wires simultaneously connectable | | Nr. | 2 |
| <hr/> | | | |
| Conductor section | AWG/Kcmil | | |
| | max | | 10 |
| <hr/> | | | |
| Flexible w/o lug conductor section | min | mm ² | 1 |
| | max | mm ² | 6 |
| <hr/> | | | |
| Flexible c/w lug conductor section | | | |

| | | | |
|---|------------------|-----------------|--------------------------|
| | min | mm ² | 1 |
| | max | mm ² | 4 |
| Flexible with insulated spade lug conductor section | | | |
| | min | mm ² | 1 |
| | max | mm ² | 4 |
| Power terminal protection according to IEC/EN 60529 | | | IP20 when properly wired |
| Cable stripping length | | | |
| | main circuit | mm | 10 |
| | command circuit | mm | 8 |
| Mechanical features | | | |
| Operating position | | | |
| | normal allowable | | Vertical plan ±30° |
| Fixing | | | Screw / DIN rail 35mm |
| Weight | | g | 496 |
| Operations | | | |
| Mechanical life | | cycles | 20000000 |
| Electrical life | | cycles | 1600000 |
| Safety related data | | | |
| Performance level B10d according to EN/ISO 13489-1 | | | |
| | rated load | cycles | 1600000 |
| | mechanical load | cycles | 20000000 |
| EMC compatibility | | | yes |
| DC coil operating | | | |
| DC rated control voltage | | V | 125 |
| DC operating voltage | | | |
| | pick-up | | |
| | min | %Us | 70 |
| | max | %Us | 125 |
| | drop-out | | |
| | min | %Us | 10 |
| | max | %Us | 40 |
| Average coil consumption ≤20°C | | | |
| | in-rush | W | 5.4 |
| | holding | W | 5.4 |
| Max cycles frequency | | | |
| Mechanical operation | | cycles/h | 3600 |
| Operating times | | | |
| Average time for Us control in AC | | | |
| | Closing NO | | |
| | min | ms | 8 |
| | max | ms | 24 |
| | Opening NO | | |
| | min | ms | 10 |
| | max | ms | 20 |
| | Closing NC | | |
| | min | ms | 14 |
| | max | ms | 28 |
| | Opening NC | | |
| | min | ms | 7 |
| | max | ms | 18 |

| | | | |
|------------|-----|----|----|
| in DC | | | |
| Closing NO | min | ms | 54 |
| | max | ms | 66 |
| Opening NO | min | ms | 14 |
| | max | ms | 17 |

UL technical data

Rated operational voltage AC (UL) V 600

Full-load current (FLA) for three-phase AC motor

| | | |
|---------|---|----|
| at 480V | A | 14 |
| at 600V | A | 17 |

Yielded mechanical performance

| | | | |
|---------------------------|----|----|--|
| for single-phase AC motor | | | |
| 110/120V | HP | 1 | |
| 230V | HP | 3 | |
| for three-phase AC motor | | | |
| 200/208V | HP | 5 | |
| 220/240V | HP | 5 | |
| 460/480V | HP | 10 | |
| 575/600V | HP | 15 | |

General USE

| | | | |
|-----------|------------|---|----|
| Contactor | AC current | A | 32 |
|-----------|------------|---|----|

Short-circuit protection fuse, 600V

| | | | |
|-----------------------|----|-----|--|
| High fault | | | |
| Short circuit current | kA | 100 | |
| Fuse rating | A | 60 | |
| Fuse class | | J | |
| Standard fault | | | |
| Short circuit current | kA | 5 | |
| Fuse rating | A | 80 | |

Ambient conditions

Temperature

| | | | |
|-----------------------|----|------|--|
| Operating temperature | | | |
| min | °C | -50 | |
| max | °C | 70 | |
| Storage temperature | | | |
| min | °C | -60 | |
| max | °C | 80 | |
| Max altitude | m | 3000 | |

Resistance & Protection

Pollution degree 3

Dimensions

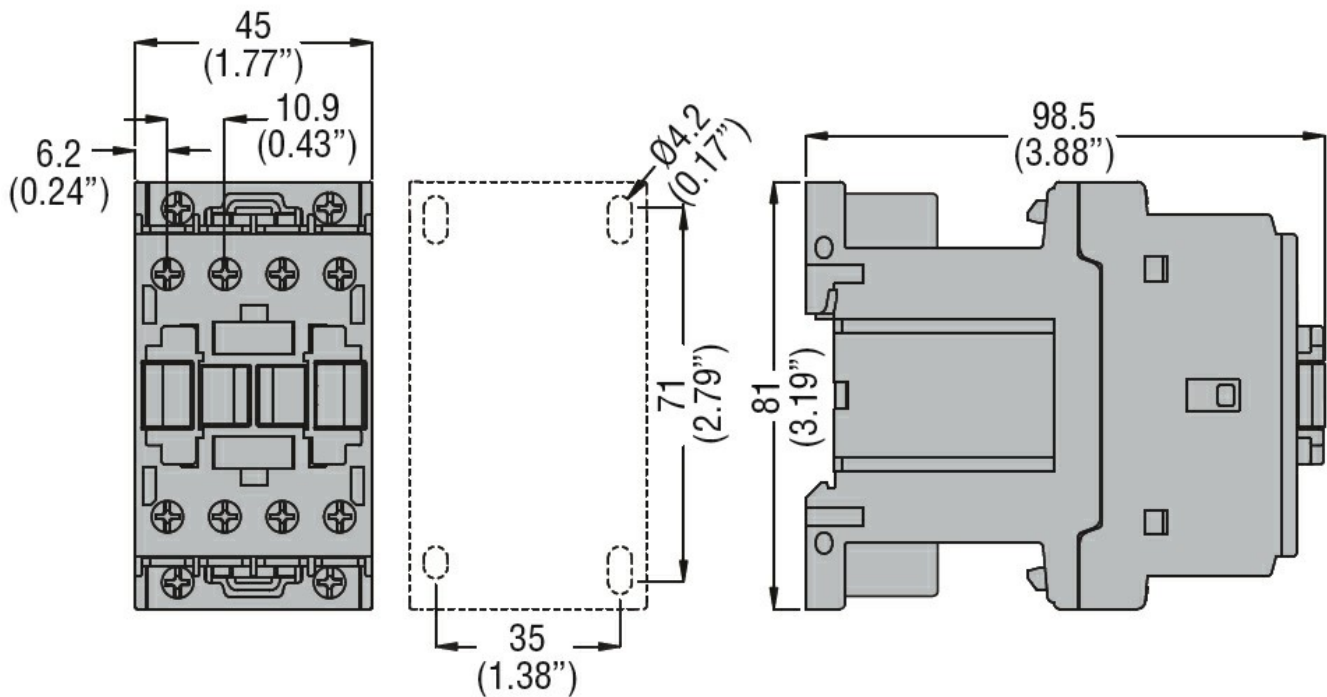

Wiring diagrams

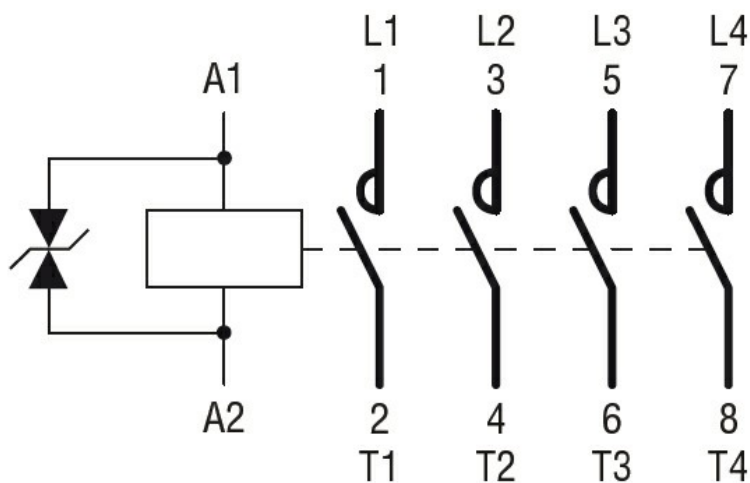

Certifications and compliance

Compliance

CSA C22.2 n° 60947-1
 CSA C22.2 n° 60947-4-1
 IEC/EN 60335-2-89
 IEC/EN/BS 60947-1
 IEC/EN/BS 60947-4-1
 UL 60947-1
 UL 60947-4-1

Certificates

CCC
 CSA C22.2 n. 60335-2-40:22 LZGH A2L
 CSA C22.2 No. 60335-2-89:21 LZGH A2L
 cULus
 EAC
 UL 60335-2-40 LZGH A2L

UL 60335-2-89 LZGH A2L

ETIM classification

ETIM 8.0

EC000066 -
Power contactor,
AC switching