



### Contact characteristics

Number of poles	Nr.	4
Rated insulation voltage U <sub>i</sub> IEC/EN	V	690
Rated impulse withstand voltage U <sub>imp</sub>	kV	6
Operational frequency	min	Hz 25
	max	Hz 400
IEC Conventional free air thermal current I <sub>th</sub> ≤ 40°C	A	45
Operational current I <sub>e</sub>	AC-1 (≤40°C)	A 45
	AC-1 (≤55°C)	A 36
	AC-1 (≤70°C)	A 32
	AC-3 (≤440V ≤55°C)	A 26
	AC-4 (400V)	A 11.5
Rated operational power AC-1 (T≤40°C)	230V	kW 17
	400V	kW 30
	500V	kW 37
	690V	kW 51
Short-time allowable current for 10s (IEC/EN60947-1)	A	210
Protection fuse	gG (IEC)	A 50
	aM (IEC)	A 32
Making capacity (RMS value)	A	260
Breaking capacity at voltage	440V	A 208
	500V	A 184
	690V	A 168
Resistance per pole (average value)	mΩ	2
Power dissipation per pole (average value)	I <sub>th</sub>	W 4
	AC-3	W 1.4
Tightening torque for terminals	min	Nm 2.5
	max	Nm 3
	min	I <sub>bin</sub> 1.8
	max	I <sub>bin</sub> 2.2
Tightening torque for coil terminal	min	Nm 0.8
	max	Nm 1
	min	I <sub>bin</sub> 0.8
	max	I <sub>bin</sub> 0.74
Max number of wires simultaneously connectable	Nr.	2
Conductor section	AWG/Kcmil	

		max		6
Flexible w/o lug conductor section		min	mm <sup>2</sup>	2.5
		max	mm <sup>2</sup>	16
Flexible c/w lug conductor section		min	mm <sup>2</sup>	1
		max	mm <sup>2</sup>	10
Flexible with insulated spade lug conductor section		min	mm <sup>2</sup>	1
		max	mm <sup>2</sup>	16
Power terminal protection according to IEC/EN 60529				IP20 when properly wired
Cable stripping length				
	main circuit	mm		10
	command circuit	mm		8
<b>Mechanical features</b>				
Operating position		normal allowable		Vertical plan ±30°
Fixing				Screw / DIN rail 35mm
Weight			g	510
<b>Operations</b>				
Mechanical life			cycles	20000000
Electrical life			cycles	1600000
<b>Safety related data</b>				
Performance level B10d according to EN/ISO 13489-1		rated load	cycles	1600000
		mechanical load	cycles	20000000
EMC compatibility				yes
<b>AC coil operating</b>				
Rated AC voltage at 50/60Hz			V	230
AC operating voltage				
	of 50/60Hz coil powered at 50Hz			
	pick-up	min	%Us	80
		max	%Us	110
	drop-out	min	%Us	20
		max	%Us	55
	of 50/60Hz coil powered at 60Hz			
	pick-up	min	%Us	85
		max	%Us	110
	drop-out	min	%Us	20
		max	%Us	55
AC average coil consumption at 20°C				
	of 50/60Hz coil powered at 50Hz			
		in-rush	VA	75
		holding	VA	9
	of 50/60Hz coil powered at 60Hz			
		in-rush	VA	70
		holding	VA	6.5

of 60Hz coil powered at 60Hz

	in-rush	VA	75
	holding	VA	9
Dissipation at holding ≤20°C 50Hz		W	2.5

**Max cycles frequency**

Mechanical operation		cycles/h	3600
----------------------	--	----------	------

**Operating times**

Average time for Us control  
in AC

Closing NO

min	ms	8
max	ms	24

Opening NO

min	ms	5
max	ms	15

Closing NC

min	ms	11
max	ms	29

Opening NC

min	ms	6
max	ms	14

**UL technical data**

Rated operational voltage AC (UL)		V	600
-----------------------------------	--	---	-----

Full-load current (FLA) for three-phase AC motor

at 480V	A	21
at 600V	A	22

Yielded mechanical performance

for single-phase AC motor

110/120V	HP	2
230V	HP	5

for three-phase AC motor

200/208V	HP	7.5
220/240V	HP	7.5
460/480V	HP	15
575/600V	HP	20

General USE

Contactor

AC current	A	45
------------	---	----

**Ambient conditions**

Temperature

Operating temperature

min	°C	-50
max	°C	70

Storage temperature

min	°C	-60
max	°C	80

Max altitude

m	3000
---	------

**Resistance & Protection**

Pollution degree

3

**Dimensions**

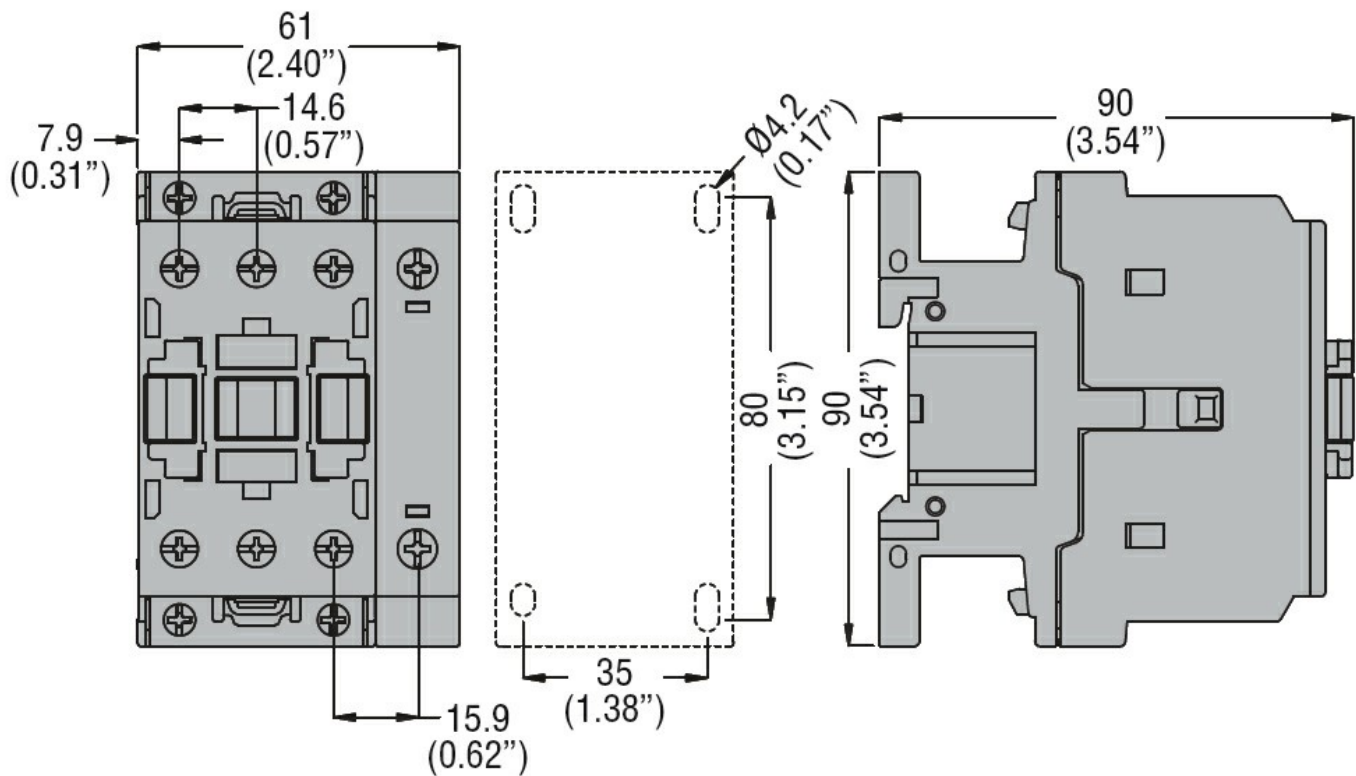

**Wiring diagrams**

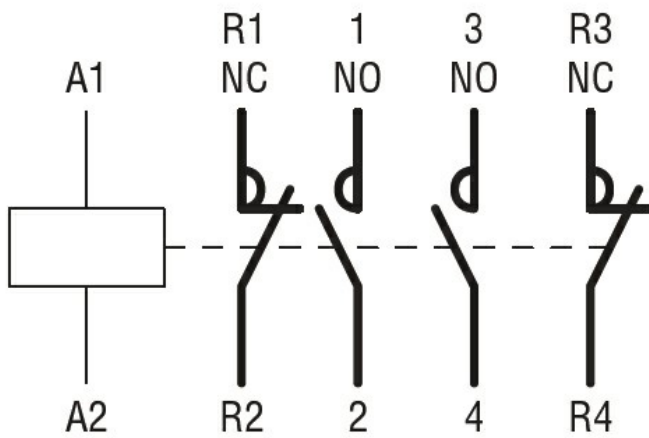

**Certifications and compliance**

**Compliance**

- CSA C22.2 n° 60947-1
- CSA C22.2 n° 60947-4-1
- IEC/EN 60335-2-89
- IEC/EN/BS 60947-1
- IEC/EN/BS 60947-4-1
- UL 60947-1
- UL 60947-4-1

**Certificates**

- CCC
- CSA C22.2 n. 60335-2-40:22 LZGH A2L
- CSA C22.2 No. 60335-2-89:21 LZGH A2L
- cULus
- EAC
- UL 60335-2-40 LZGH A2L

---

UL 60335-2-89 LZGH A2L

ETIM classification

ETIM 8.0

EC000066 -  
Power contactor,  
AC switching