



Auxiliary supply

Rated auxiliary supply voltage U_s

AC

min	VAC	100
Max	VAC	415

DC

min	VDC	110
Max	VDC	250

Auxiliary operating range		90...484VAC / 93.5...300VDC
Auxiliary rated frequency	Hz	50/60 \pm 10%
Power consumption Max	VA	27 (with 4 EXP modules)
Power dissipation Max	W	10.5 (with 4 EXP modules), 5.5 (with no EXP modules)
Immunity time for microbreakings	ms	\geq 35ms (110VAC); \geq 80ms (220...415VAC)

Voltage inputs

Rated voltage (U_e)	VAC	600VAC L-L (rated max)
Operating range		50...720VAC L-L (415VAC L-N)
Frequency range	Hz	45...65 Hz / 360...440 Hz
Type of measure		True RMS value
No-voltage release	ms	\geq 8
Measurement input impedance	k Ω	>1.10M Ω L-L, >0.55M Ω L-N
Type of connection		Single phase, two phase, three phase with or without neutral or balanced three phase system

Current inputs

Number of current input	Nr.	3
Type of input		Shunt supplied by external current transformer (low voltage). Max 5A

Measurement range		0.025...6A~ for 5A scale; 0.025...1.2A~ for 1A scale
Measurement method		True RMS value
Constant overload	I _e	1.2 I _e
Overload peak	A	50A for 1s
Burden per phase	W	<0.6VA
Measurement data		
Type of voltage and current measurement		True RMS value
Power factor adjustment		0.5ind...0.5cap.
Type of temperature sensor		Internal + PT100 with EXP1004 + NTC with EXP1016
Temperature measurement range	°C	0...+212
Relay outputs		
Number of relay output	Nr.	8 (up to 18 with EXP10 06 - EXP10 07)
Contact arrangement		7 NO-SPST + 1 C/O-SPDT
Rated current		5A 250V AC1
UL/CSA and IEC/EN 60947-5-1 designation		B300
Maximum current at common contact terminal	A	10
Maximum switching voltage	VAC	415
Electrical life (with rated load)	cycles	10 ⁵
Mechanical life	cycles	30 x 10 ⁶
Static Outputs		
Number of static output		0 (up to 8 with EXP1001)
Insulations		
Rated insulation voltage U _i IEC/EN	V	600
Rated impulse withstand voltage U _{imp}	kV	9.5
Operating frequency withstand voltage	kV	5.2
Functions		
Automatic recognition of current flow direction		Yes
4-quadrant operation		Yes
Master-Slave function		No
Independent auxiliary supply input		Yes
Three-phase voltage control		Yes
Current inputs		3
Dynamic (FAST) power factor correction		Yes
Power factor correction by single phase		Yes
Possibility of connecting inductive steps		Yes
Possibility of use in medium voltage		Yes
Possibility of phase-neutral insertion on a three-phase system		Yes
Analog outputs		Yes
Input programmable as function or external temperature sensor		Yes
USB communication interface		Yes
RS232 communication interface		Yes
Opto-isolated RS485 communication interface		Yes
Ethernet communication interface		Yes
Opto-isolated Profibus-DP interface		Yes

GPRS/GSM modem	Yes
Optical port on front for the connection of USB devices	Yes
Optical port on front for the connection of Wi-Fi devices	Yes
Fast setting of current transformer	Yes
Compatible with Xpress configuration and remote control software	Yes
Compatible with Synergy and Synergy Cloud, supervision and energy management software	Yes
Compatible with Sam1 App	Yes
Calendar-clock with backup reserve power	Yes
Data logging memory	Yes
Event logging: alarms, setup changes, etc.	Yes
Customisable internal counters	Yes

Connections

Type of terminal	Plug-in, removable		
Conductor cross section	min	mm ²	0.2
	Max	mm ²	2.5
	min	AWG	24AWG (18AWG according to UL/CSA)
	Max	AWG	12
Tightening torque (Max)	Nm	0.56	
	lbin	5lbin (4-5lbin according to UL/CSA)	

Ambient conditions

Temperature	Operating temperature		
	min	°C	-20
	max	°C	+70
	Storage temperature		
	min	°C	-30
	max	°C	+80
Relative humidity			% <80%
Maximum Pollution degree			2
Overvoltage category			3
Measurement category			III
Climatic sequence			Z/ABDM (IEC/EN 60068-2-61)
Shock resistance			15g (IEC/EN 60068-2-27)
Vibration resistance			0.7g (IEC/EN 60068-2-6)

Housing

Execution	Flush mount		
Material	Polycarbonate		
Mounting	Flush-mount 144x144mm (5.67x5.67")		
Degree of protection	IP65 on front, IP20 terminals		
Dimensions (W x H x D)	mm	144 x 144 x 53.2	
Weight	g	980	

Dimensions

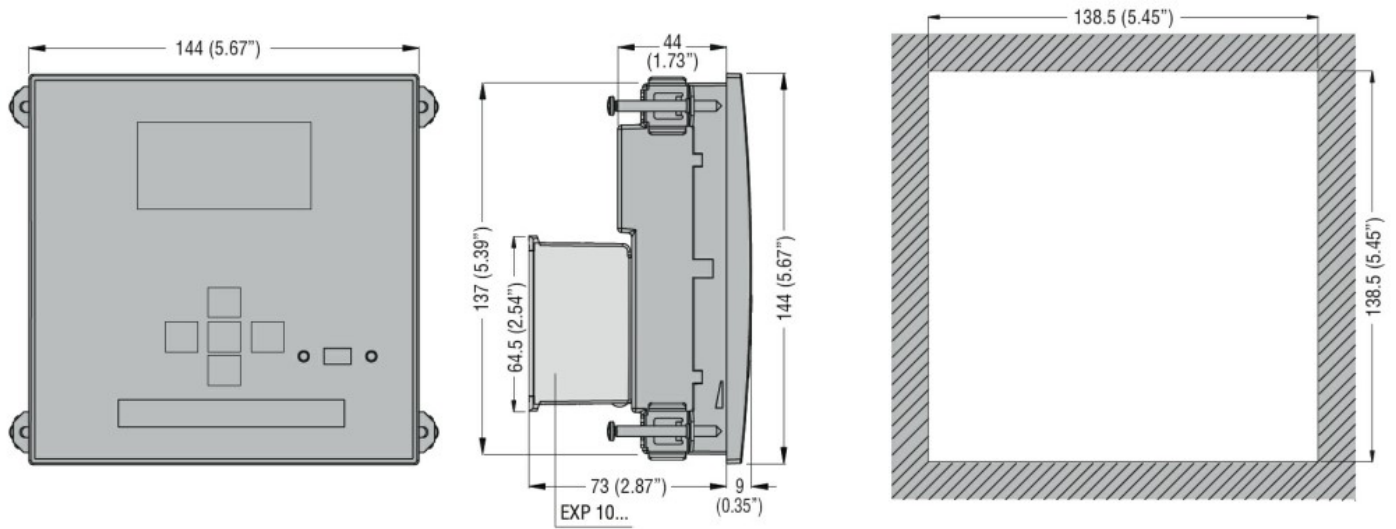

Wiring diagrams

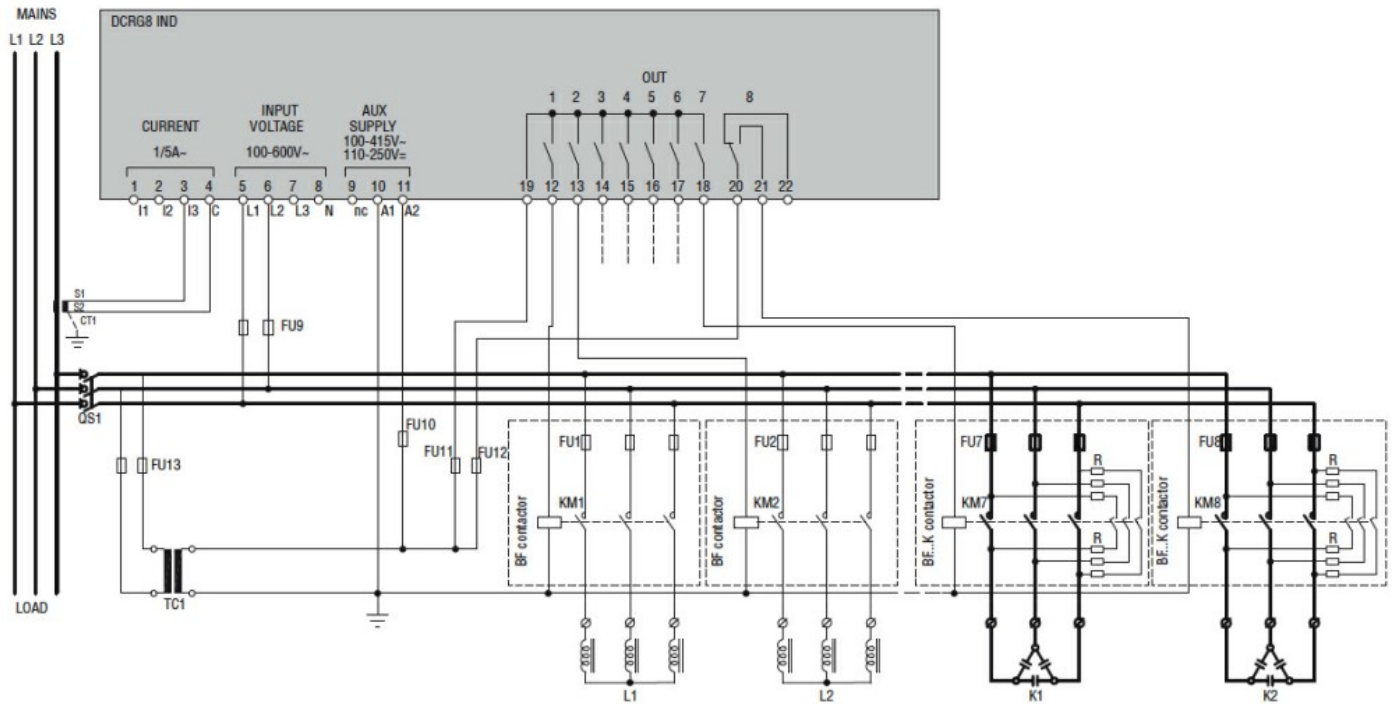

Certifications and compliance

Compliance

CSA C22.2 n°14
IEC 61010-1
IEC/EN 61000-6-2
IEC/EN 61000-6-3
UL 508

Certificates

cULus
EAC

ETIM classification

ETIM 8.0

EC001443 -
Effective power
(cos phi)
monitoring relay