



General characteristics

Description	Capacitor bank protection
Functions	Capacitor bank protections
Compatibility with LOVATO Electric product	
Automatic power factor controllers	DCRG8 Yes

Mechanical features

Weight	g	80
--------	---	----

Dimensions

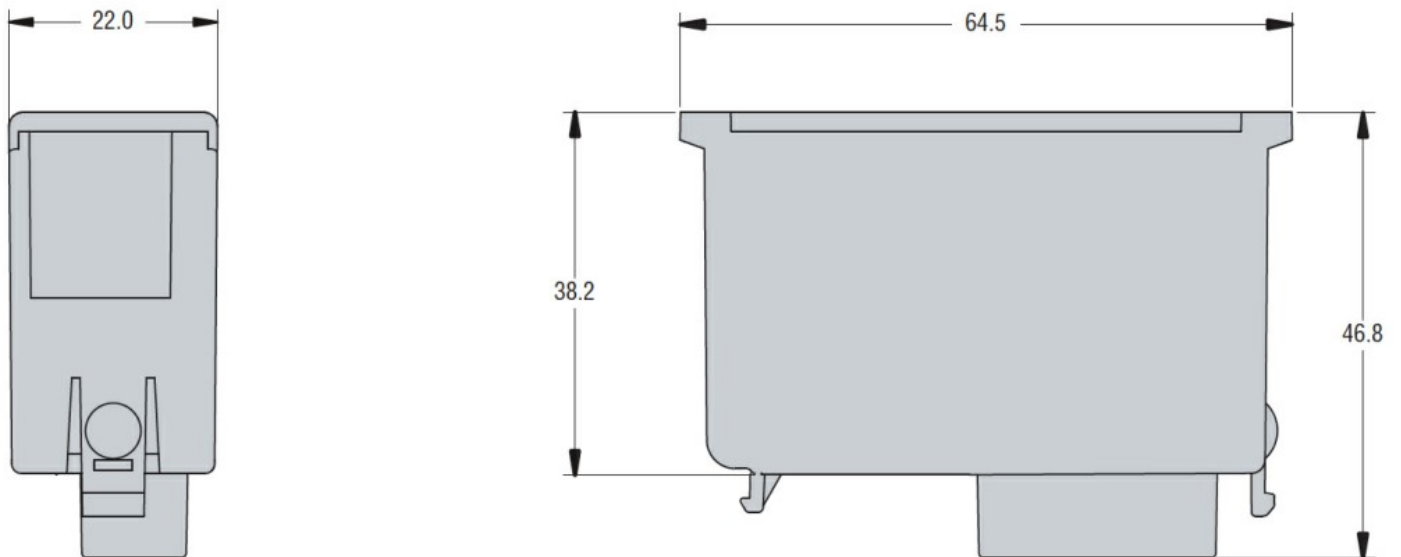

Wiring diagrams

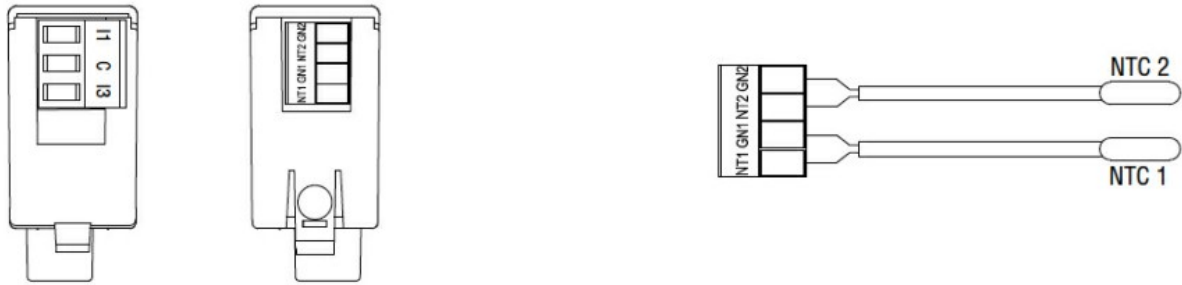

Harmonic current measurements / Misura correnti armoniche

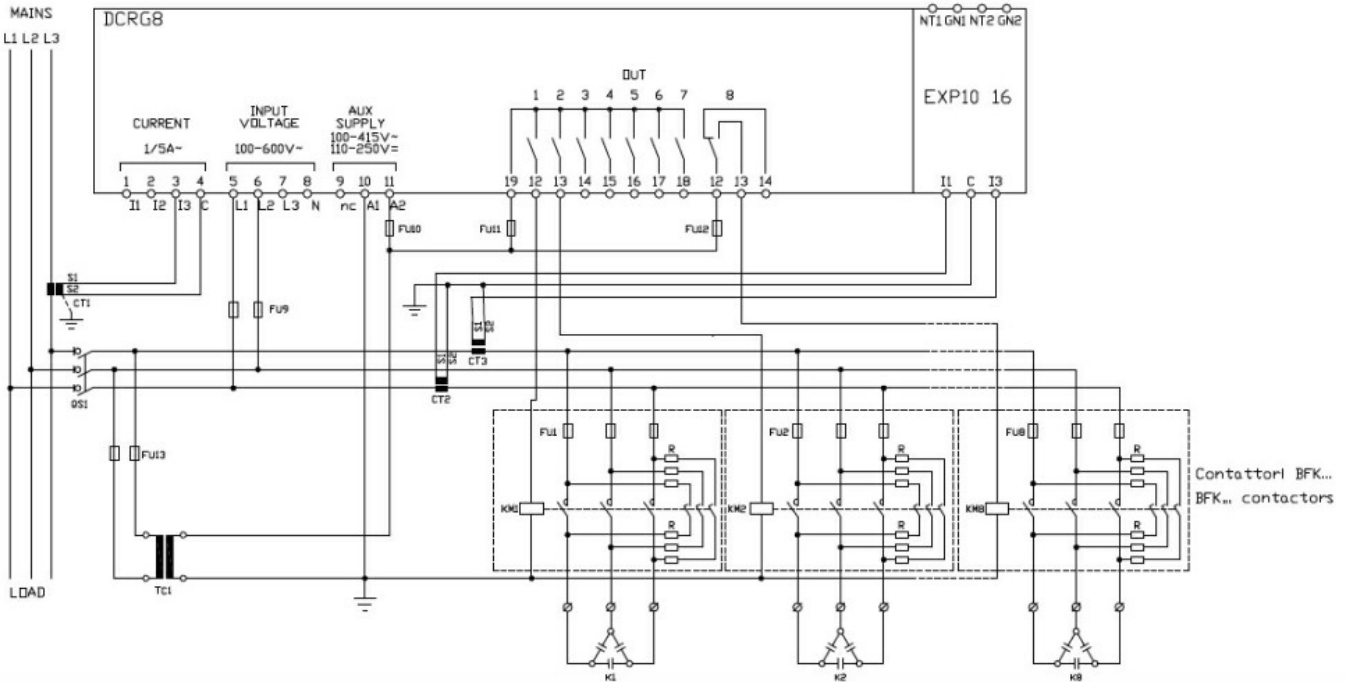

Certifications and compliance

Compliance

- CSA C22.2 n° 14
- IEC/EN 61000-6-2
- IEC/EN 61000-6-3
- IEC/EN 61010-1
- UL508

Certificates

- cULus
- EAC

ETIM classification

ETIM 8.0

EC002498 -
Accessories/spare
parts for low-
voltage switch
technology