

### General characteristics

Switching diagram	19 - Dahlander motor control switch 0-1-2
N° of elements	4
Mounting form	P - Plastic enclosure with black handle

### Contact characteristics

Rated insulation voltage $U_i$	IEC/EN	V	690	
	UL/CSA	V	600	
Rated impulse withstand voltage $U_{imp}$		kV	6	
Conventional free air thermal current $I_{th}$	IEC/EN	A	16	
	UL/CSA	A	12	
Rated operational voltage		V	440	
Rated operational impulse voltage		kV	4	
Maximum fuse size for short-circuit protection $I_n$ (gG)	10kA	A	16	
	15kA	A	16	
	25kA	A	16	
Rated short time current $I_{cw}$	1s	kA	250	
			10/5 mA/V	
Conductivity				
Operational current $I_e$ IEC/EN	AC1/AC21A		A	16
	AC15			
	110V	A	10	
	220/230V	A	8	
	380/400V	A	4	
	660/690V	A	1.5	
Rated operational power in AC	Three-phase AC-3			
	220/230V	kW	3.5	
	380/440V	kW	4.5	
	500/690V	kW	5.5	
	Single-phase AC-3			
	110V	kW	0.55	
	220/230V	kW	1.5	
	380/440V	kW	2.2	
	Three-phase AC23A			
	220/230V	kW	3.7	
	380/440V	kW	6.5	
	500/690V	kW	7.5	
Single-phase AC23A				
110V	kW	0.75		
220/230V	kW	1.8		
380/440V	kW	3		
Rated operational current in DC	DC21A			
	48V	A	16	

	60V	A	16
	110V	A	4
	220V	A	0.6
	440V	A	0.25
<hr/>			
DC23A (poles in series)	24V	A	16 (1)
	48V	A	16 (2)
	60V	A	16 (3)
	110V	A	10 (3)
	220V	A	7 (4)
<hr/>			
DC13	24V	A	16
	48V	A	14
	60V	A	10
	110V	A	1
	220V	A	0.4
	440V	A	0.15
<hr/>			
Power dissipation		W	0.6
<b>Mechanical features</b>			
Terminals screw			3M
Tightening torque for terminals max		Nm	0.5
<hr/>			
Conductor size			
AWG - Rigid cable	min	AWG	20
	Max	AWG	12
<hr/>			
AWG - Flexible cable	min	AWG	20
	Max	AWG	12
<hr/>			
Conductor size (IEC) - Flexible cable	min	mm <sup>2</sup>	0.5
	Max	mm <sup>2</sup>	2.5
<hr/>			
Conductor size (IEC) - Rigid cable	min	mm <sup>2</sup>	0.5
	Max	mm <sup>2</sup>	2.5
<hr/>			
Mechanical life		cycles	1X10 <sup>6</sup>
<b>UL technical data</b>			
Motor power for direct-on-line control			
for three-phase motor	120V	HP	1.5
	240V	HP	3
	480V	HP	5
	600V	HP	5
<hr/>			
for single-phase motor	120V	HP	0.75
	240V	HP	1
<hr/>			
<b>Ambient conditions</b>			
Temperature			
Operating temperature	min	°C	-25
	max	°C	+55
<hr/>			
Storage temperature	min	°C	-40
	max	°C	+70
<hr/>			
<b>Resistance &amp; Protection</b>			

Frontal IP degree	IP65
Terminals IP degree	IP20

**Dimensions**

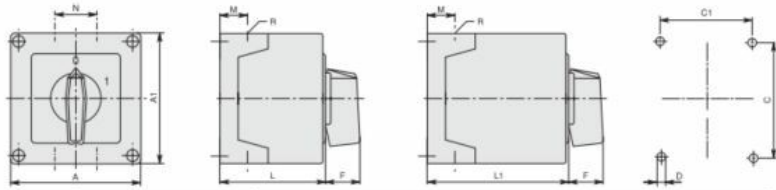

Series	Enclosure size	Number of elements		Dimensions										Cable entry	Protection degree
		L	L1	A	A1	C	C1	D	F	M	N	L	L1		
GX1600	90x90	1-2	3-5	90	90	79	79	4.5	25	19	30	71.3	98.3	4xPG16	IP65
		1-2	3-5												
GX16	110x110	1-3	4-7	110	110	98.4	83	4.5	32	21	39.5	85.5	119.5	4xPG21	IP65
		1-3	4-7												
GX20		1-2	3-4												
GX3200		1-2	3-4												
GX4000		1-2	3-4												

**Wiring diagrams**

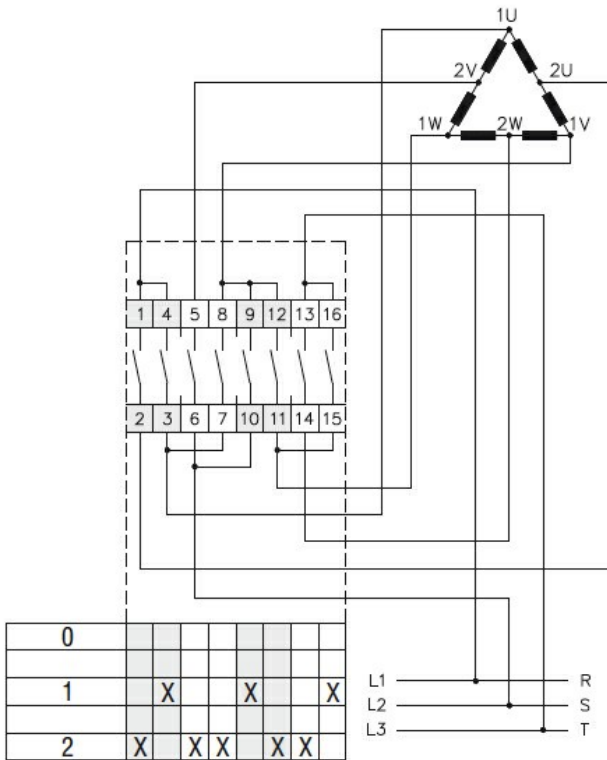

**Certifications and compliance**

**Compliance**

- IEC/EN/BS 60947-1
- IEC/EN/BS 60947-3
- IEC/EN/BS 60947-5-1
- IEC/EN/BS 61058-1

**Certificates**

EAC

**ETIM classification**

ETIM 8.0

EC001029 -  
Selector switch,  
complete