



General characteristics

Material

Housing	Aluminium-zinc alloy
Roller	Metal

Contact characteristics

Type of contact

2NC Slow action make before break

Thermal current I _{th}	A	10
IEC/EN 60947-5-1 designation		A300 Q300
Rated insulation voltage U _i	V	440
Rated impulse withstand voltage U _{imp}	kV	4

Short-circuit protection with fuse	Class/A	10 gG/SC QUICK FUSE
------------------------------------	---------	---------------------

Switching speed

min	m/s	0.5
max	m/s	1.5

IEC Conventional free air thermal current I _{th} ≤ 40°C	A	10
--	---	----

Resistance per pole (average value)	mΩ	<10
-------------------------------------	----	-----

Mechanical features

Operating head fixing		Locking bayonet insert
-----------------------	--	------------------------

Operating torque

N	6
lb	1.34

Tightening torque (Max)

Switch fixing

Nm	2.5
lbin	22.1

Contact terminals

Nm	0.8
lbin	7

Body lid screw fixing

Nm	0.8
lbin	7

Conductor section

AWG/Kcmil

min	16
max	14

IEC

min	mm ²	1.5
max	mm ²	2.5

Cable connection

Self-releasing screw terminal

Cable entry	M20 on the bottom
-------------	-------------------

Operations

Mechanical life	cycles	<10000000
Mechanical operation	cycles/h	3600

Ambient conditions

Temperature	Operating temperature	min	°C	-25
		max	°C	+70
	Storage temperature	min	°C	-40
		max	°C	+70

Resistance & Protection

IP degree	Terminals	IP20
	Body housing	IP65
Pollution degree		3

Dimensions

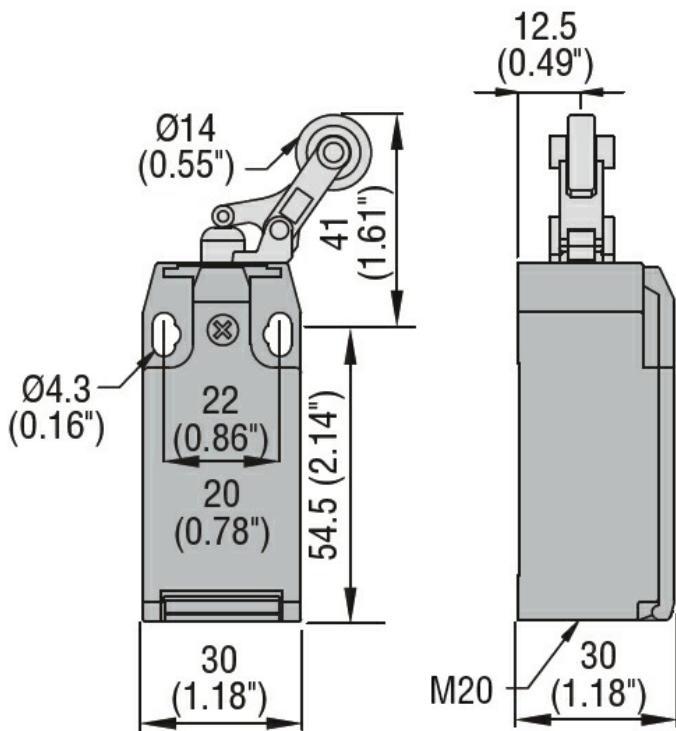

Wiring diagrams

Slow action



1NO + 1NC
make before break

Certifications and compliance

Compliance

CSA C22.2 n° 14

EN 50047

IEC/EN 60204-1

IEC/EN 60947-1

IEC/EN 60947-5-1

UL508

Certificates

CCC

cULus

EAC

ETIM classification

ETIM 8.0

EC000030 - End
switch