



General characteristics			
General characteristics			
Housing Material		Aluminium-zinc alloy	
Rod material		Short cylinder hinge	
Contact characteristics			
Type of contact		1NO+1NC Slow action	
Thermal current I _{th}	A	10	
IEC/EN 60947-5-1 designation		A300 Q300	
Rated insulation voltage U _i	V	440	
Rated impulse withstand voltage U _{imp}	kV	4	
Short-circuit protection with fuse	Class/A	10 gG/SC QUICK FUSE	
Switching speed		min	m/s 0.5
		max	m/s 1.5
IEC Conventional free air thermal current I _{th} ≤ 40°C	A	10	
Resistance per pole (average value)	mΩ	<10	
Operations			
Mechanical life		cycles	100000
B10d		cycles	100000
Mechanical operation		cycles/h	3600
Output characteristics			
Mechanical life		cycles	100000
Mechanical features			
Operating head fixing		Locking bayonet insert	
Operating torque		Ncm	15
		ozin	21.2
Tightening torque (Max)			
Switch fixing		Nm	2.5
		lbin	22.1
Contact terminals		Nm	0.8
		lbin	7
Body lid screw fixing		Nm	0.8
		lbin	7
Conductor section			
AWG/Kcmil		min	16
		max	14

IEC

min	mm ²	1.5
max	mm ²	2.5

Cable connection

Self-releasing screw terminal

Cable entry

M20 on the bottom

Ambient conditions

Pollution degree

3

Temperature

Operating temperature

min	°C	-25
max	°C	+70

Storage temperature

min	°C	-40
max	°C	+70

Dimensions

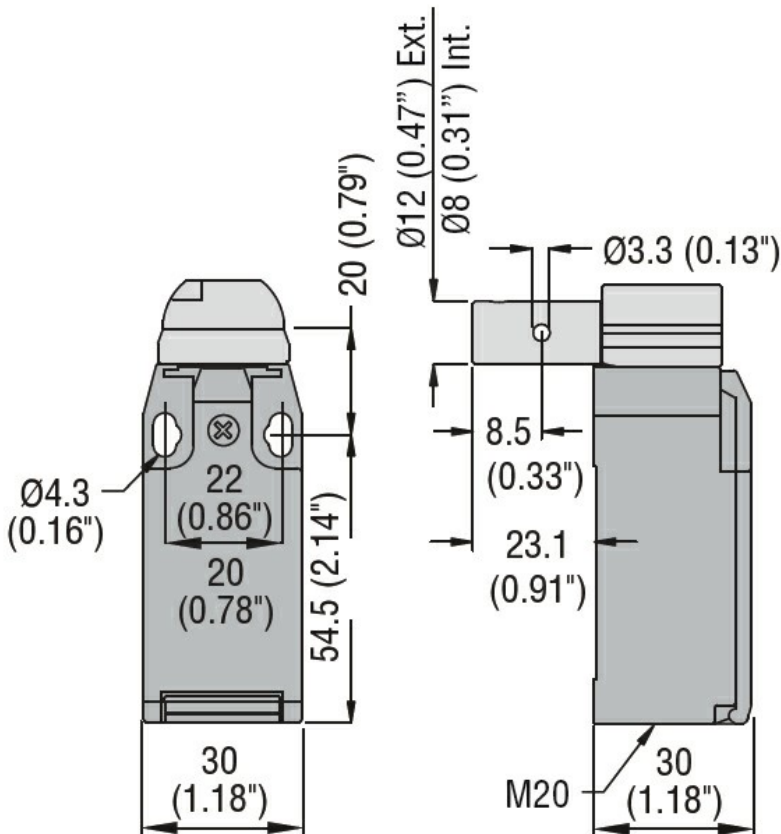

Wiring diagrams

Slow action

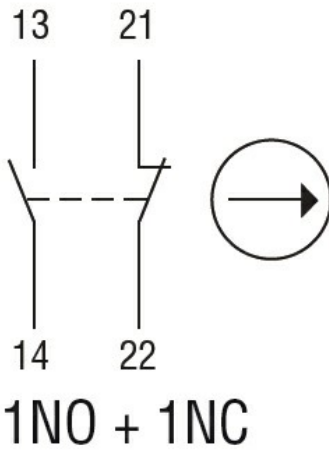

Certifications and compliance

Compliance

CSA C22.2 n° 14

EN 50047

IEC/EN 60204-1

IEC/EN 60947-1

IEC/EN 60947-5-1

UL508

Certificates

CCC

cULus

EAC

ETIM classification

ETIM 8.0

EC000030 - End switch