



Electrical features

Relay adj range	A	2.5-4
IEC technical characteristics ($\leq 440V$)	le kW	A kW 4 1.1...1.5

Components

Starter enclosure standard supplied	M1PA
Contactor standard supplied	BF0910A
Thermal relay standard supplied	RF380400

UL technical data

Maximum UL/CSA horsepower ratings three-phase, 3-pole	200V-208V	HP	0.75
	220V-240V	HP	0.75
	440V-480V	HP	2
	550V-600V	HP	3
UL degree of protection	Type 1, 12K, 4, 4X		

Mechanical features

Weight	g	1040
--------	---	------

Ambient conditions

Operating temperature	min	°C	-25
	max	°C	+60
Storage temperature	min	°C	-40
	max	°C	+70

Resistance & Protection

IEC degree of protection	IP65
--------------------------	------

Dimensions

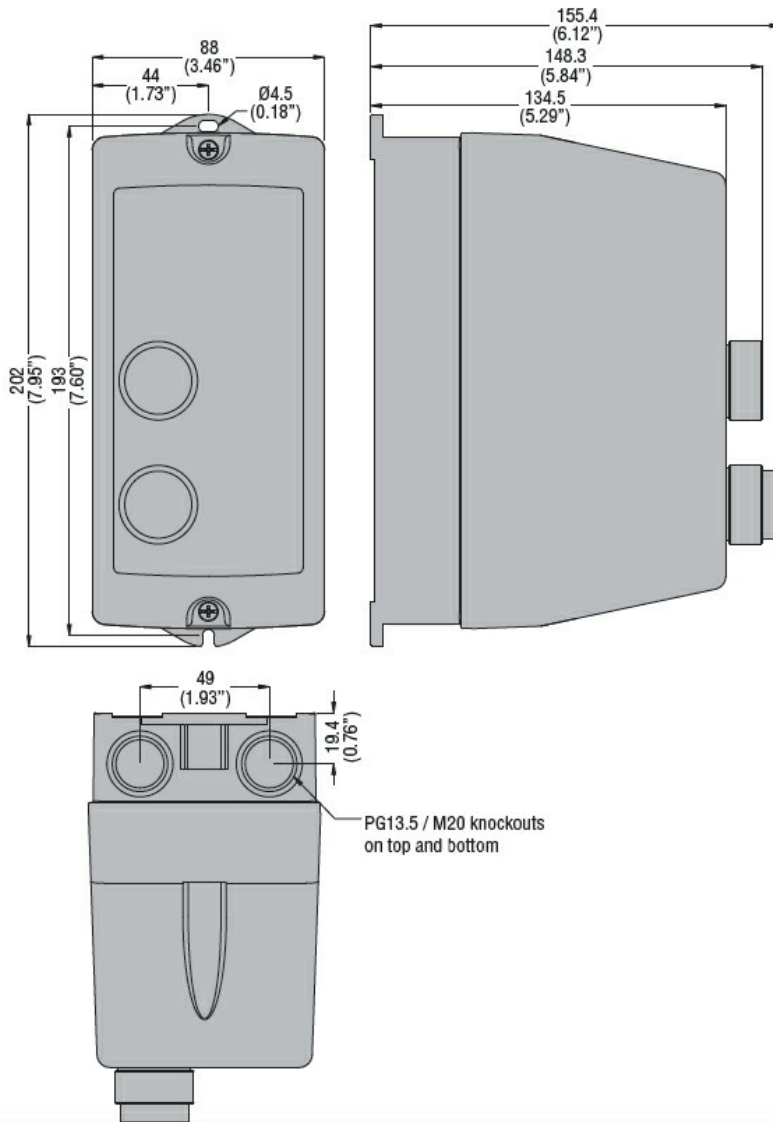

Wiring diagrams



I = Start; O = Stop/Reset

Certifications and compliance

Compliance

IEC/EN 60947-1
IEC/EN 60947-4-1
UL508 CSA C22.2 n° 14

Certificates

CSAus
cULus
EAC

ETIM classification

ETIM 8.0

EC001037 -
Motor
starter/Motor
starter
combination