



**Electrical features**

Rated impulse withstand voltage Uimp	kV	4
Rated operational voltage AC (IEC)	VAC	400
Rated current (In)	A	6
Conductivity		24V 10mA

**Ambient conditions**

Operating temperature	min	°C	-40
	max	°C	+70
Storage temperature	min	°C	-40
	max	°C	+80

**Mechanical features**

Operating position	normal allowable	Vertical plan	Any
Tightening torque for terminals	min	Nm	1
	max	Nm	1
	min	Ibin	0.7
	max	Ibin	0.7
Terminals tool			PH2
Conductor section	IEC		
	max	mm <sup>2</sup>	1x 2.5 - 2x 1.5
Weight		g	40

**Dimensions**

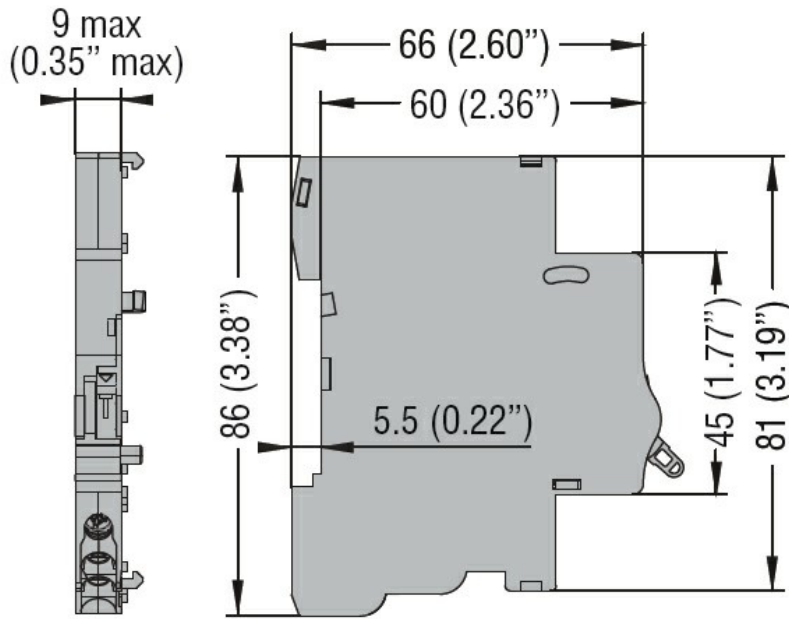

**Wiring diagrams**

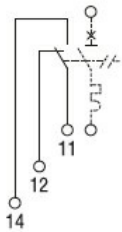

**Certifications and compliance**

**Compliance**

IEC/EN 60947-5-1. UR "UL Recognized" per Canada e USA.

**Certifications**

cULus  
 EAC

**ETIM classification**

ETIM 8.0

EC000041 -  
 Auxiliary contact  
 block