



Mechanical features

Weight

g 123

Dimensions

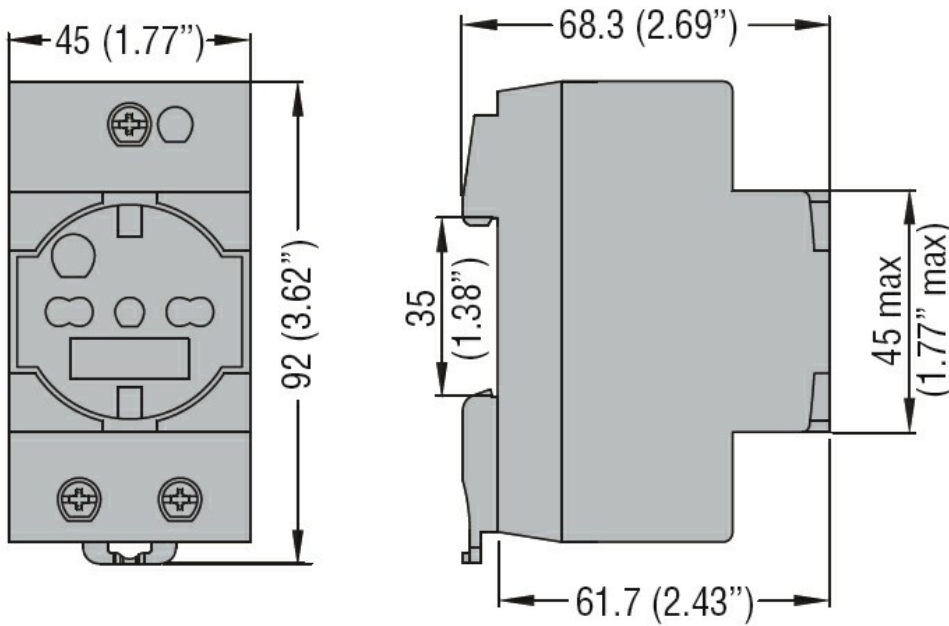

Certifications and compliance

Compliance

IEC/EN 60884-1

Certifications

EAC

ETIM classification

ETIM 8.0

EC000330 -
Multiple socket