



General characteristics

Description	Medium-voltage system. Dual threshold minimum and maximum voltage and frequency protection		
Power supply			
Operating voltage range	90...440VAC / 93.5...300VDC		
Rated frequency	Hz	45...55	
Control circuit			
Rated current (Ie)	A	CT /5A /1A	
Auxiliary supply			
Rated auxiliary supply voltage Us			
AC	min	VAC	100
	Max	VAC	400
DC	min	VDC	110
	Max	VDC	250
Power consumption			
AC (Max)	VA	7.5VA at 110VAC; 10VA at 230VAC; 14VA at 400VAC	
DC (Max)	VA	35mA at 110VDC; 14mA at 250VDC	
Power dissipation			
AC (Max)	W	4W at 110VAC; 4.2W at 220VAC; 5W at 400VAC	
DC (Max)	W	3.8W at 110VDC; 4W at 250VDC	
Immunity time for microbreakings	ms	≤30ms at 110VAC; ≤140ms at 230VDC	

Voltage inputs

Maximum rated operational voltage			50...500VAC (for voltages/frequency / 50...150V (for residual voltage measurement))
Measurement range		V	400-150000V (VT primary)
Frequency range		Hz	45...55
Current inputs			
Measurement range			For 1A scale: 0.01...1.2A; for 5A scale: 0.01...6A
Type of input			Shunts powered by external current transformer (low voltage) 5A max
Measurement method			RMS
Overload peak		A	50A for 1 second
Burden per phase		W	≤0.3W
Relay outputs			
Number of relays		Nr.	2
Contact arrangement			1 changeover contact/SPDT each
Rated operational voltage AC (IEC)		VAC	250
UL/CSA and IEC/EN 60947-5-1 designation			5A 250VAC AC1/B300; 5A 30VDC
Digital inputs			
Number and type of inputs			4 negative (NPN)
Input voltage			24VDC isolated
Input current		mA	7
Connections			
Terminals type			Screw - removable
Tightening torque for terminals		max	Nm 0.5
		max	lbin 4.5
Conductor cross section			
	AWG/Kcmil	min	AWG 24
		Max	AWG 12
	IEC	min	mm ² 0.2
		Max	mm ² 2.5
Housing			
Material			Polyamide
Mounting			Flush mount 96x96mm / 3.78x3.78"
IEC degree of protection			IP65 on front; IP20 at terminals
Dimensions (W x H x D)		mm	96 x 96 x 53.2
Weight		g	566

Dimensions

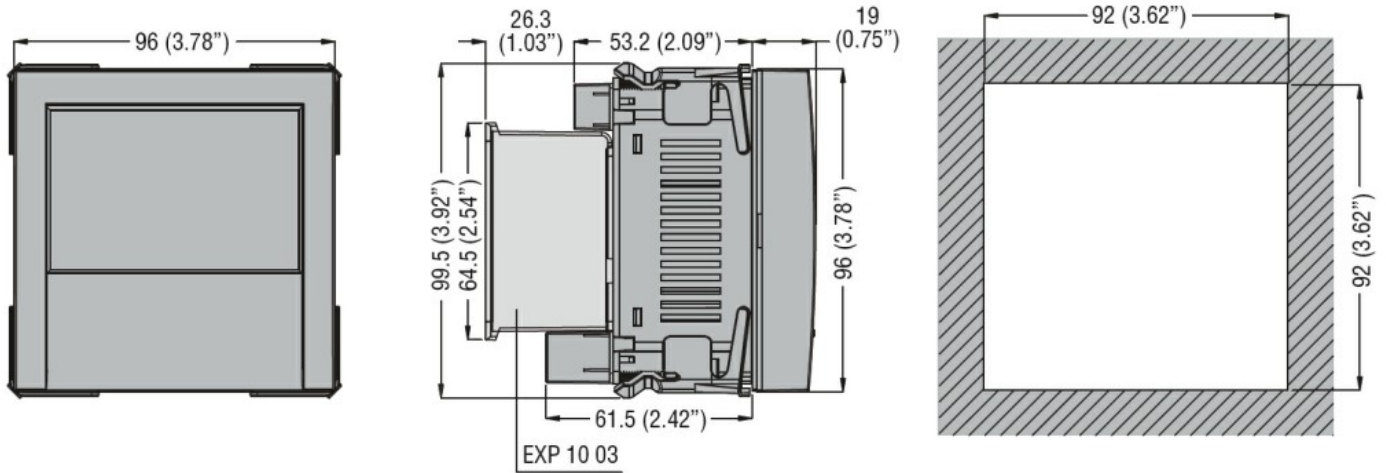

Wiring diagrams

Connection through VTs in Medium Voltage
Three-phase connection

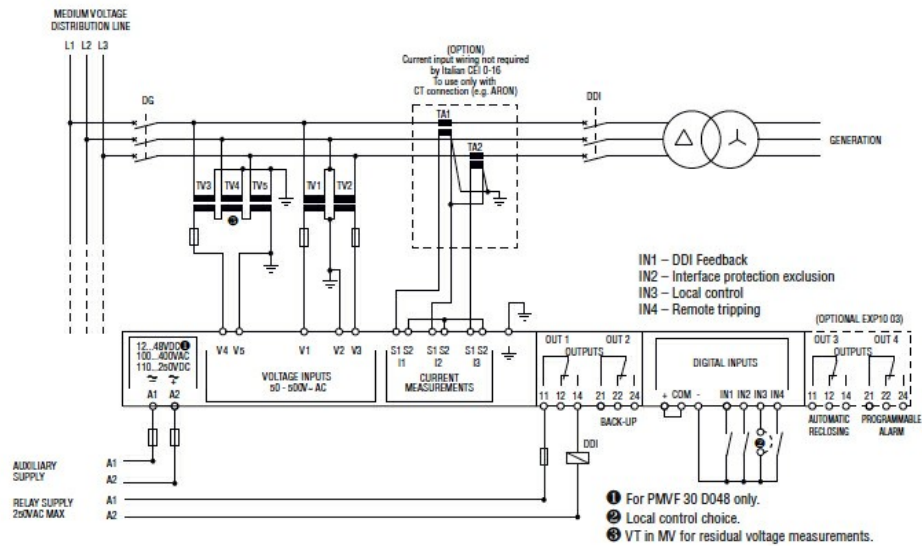

Direct connection in Low Voltage
Three-phase connection

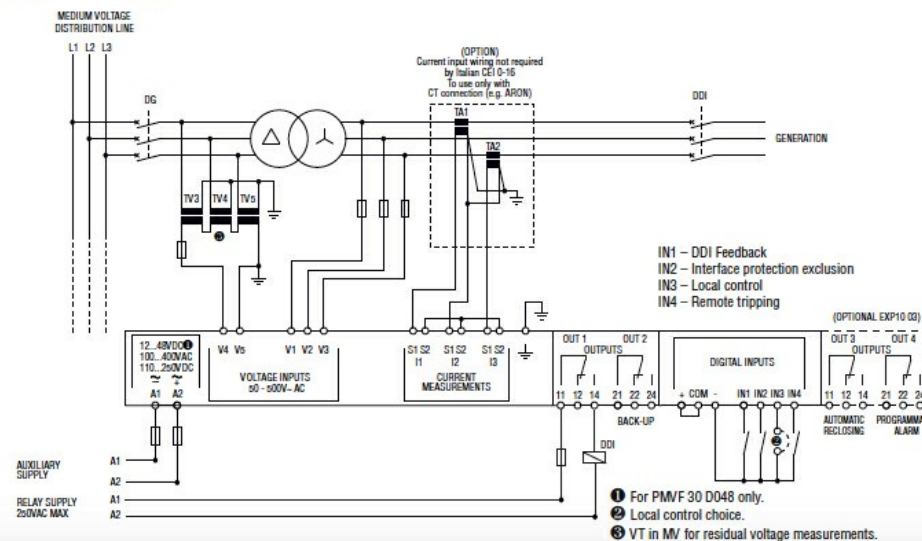

Certifications and compliance

Compliance

IEC/EN 60255-5

IEC/EN 61000-6-2

IEC/EN 61000-6-3

IEC/EN 61010-1

Certificates

CEI 0-16

ETIM classification

ETIM 8.0

EC001438 -
Voltage
monitoring relay