

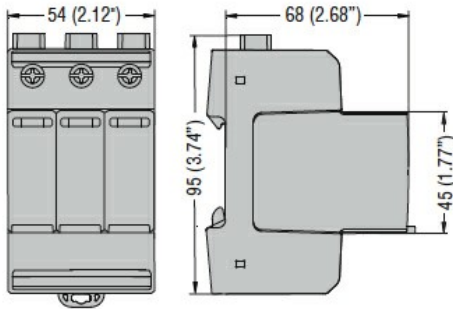

Dimensions



Certifications and compliance

Compliance

IEC/EN/BS 50539-11

Certificates

EAC

ETIM classification

ETIM 8.0

EC002496 -
 Accessories/spare
 parts for surge
 protection power
 supply systems